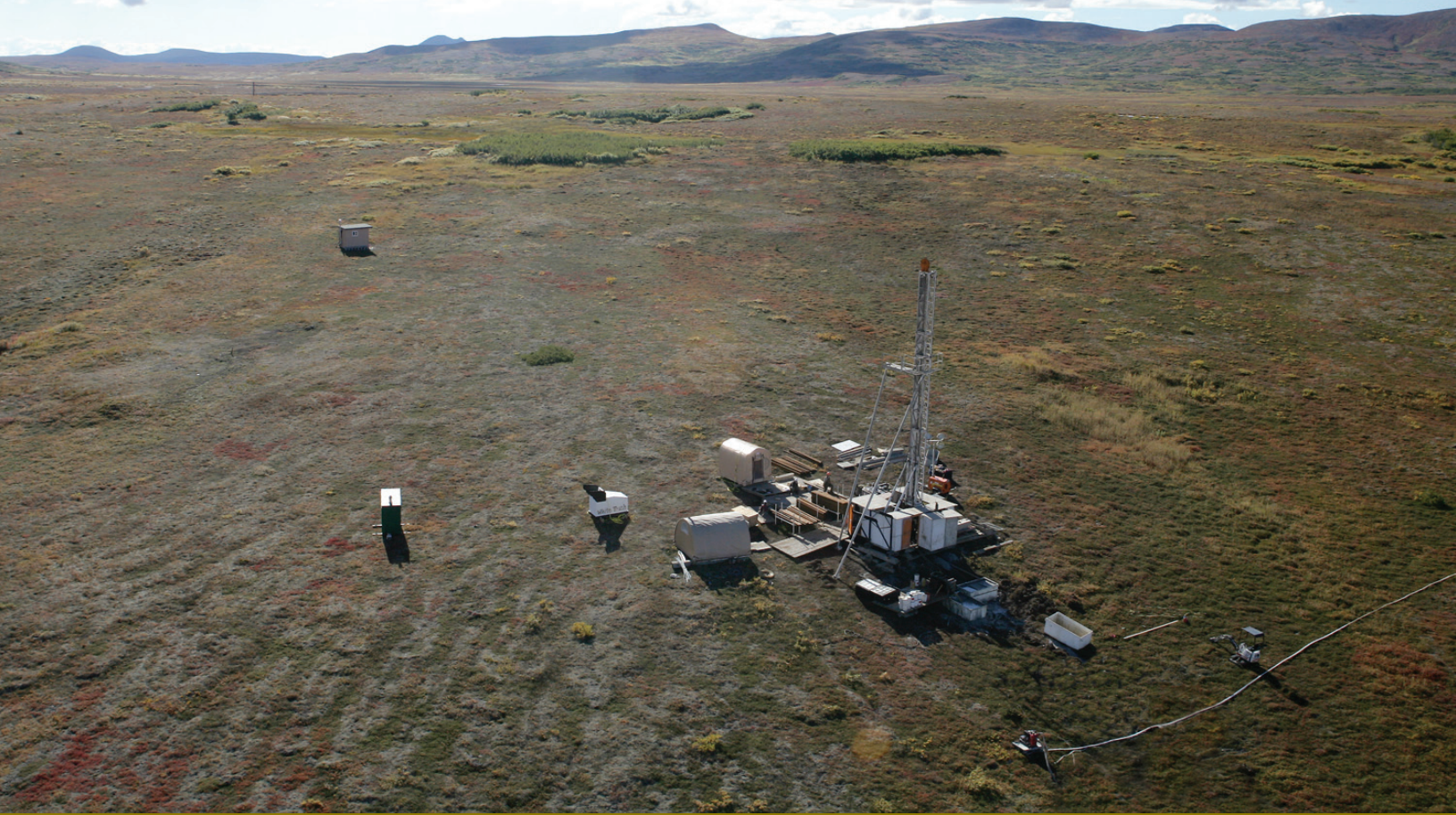




*Northern Dynasty Minerals Ltd.*



# **Preliminary Assessment of the Pebble Project Southwest Alaska**

**Effective Date:** February 15th, 2011

**Issue Date:** February 17th, 2011

1056140100-REP-R0001-00

**WARDROP**  
A TETRA TECH COMPANY



Report to:



**Preliminary Assessment of the  
Pebble Project, Southwest Alaska**

Document No. 1056140100-REP-R0001-00



Report to:



# PRELIMINARY ASSESSMENT OF THE PEBBLE PROJECT, SOUTHWEST ALASKA

EFFECTIVE DATE: FEBRUARY 15, 2011

DATE OF ISSUE: FEBRUARY 17, 2011

Prepared by Hassan Ghaffari, P.Eng.  
Dr. Robert Sinclair Morrison, P.Geo.  
Marinus Andre de Ruijter, P.Eng.  
Aleksandar Živković, P.Eng.  
Tysen Hantelmann, P.Eng.  
Douglas Ramsey, R.P.Bio.  
Scott Cowie, MAusIMM

JS/alm



Suite 800, 555 West Hastings Street, Vancouver, British Columbia V6B 1M1  
Phone: 604-408-3788 Fax: 604-408-3722 E-mail: vancouver@wardrop.com



## REVISION HISTORY

---

REV. NO	ISSUE DATE	PREPARED BY AND DATE	REVIEWED BY AND DATE	APPROVED BY AND DATE	DESCRIPTION OF REVISION
00	Feb. 15/11	All QPs, Feb.15/11	Jeffrey Selder, Feb. 15/11	Hassan Ghaffari Feb. 15/11	Final draft issued.





# TABLE OF CONTENTS

---

<b>1.0</b>	<b>EXECUTIVE SUMMARY.....</b>	<b>1</b>
1.1	PROJECT OVERVIEW.....	1
1.1.1	LAND STATUS AND PROJECT OWNERSHIP.....	2
1.1.2	PRELIMINARY ASSESSMENT DEVELOPMENT CASES.....	3
1.1.3	PROJECT PLANNING ALTERNATIVES.....	5
1.1.4	MINERAL RESOURCE ESTIMATES.....	6
1.1.5	MINE PLANNING.....	6
1.1.6	MINE DEVELOPMENT.....	7
1.1.7	INFRASTRUCTURE.....	8
1.1.8	PROJECT WORKFORCE.....	10
1.1.9	PRODUCTION PROFILES.....	10
1.1.10	FINANCIAL RESULTS.....	12
1.2	LOCATION AND ACCESS.....	17
1.3	TENURE, SURFACE RIGHTS AND AGREEMENTS.....	19
1.4	GEOLOGY AND EXPLORATION.....	20
1.4.1	HISTORY.....	20
1.4.2	GEOLOGY.....	21
1.4.3	MINERALIZATION.....	23
1.4.4	EXPLORATION HISTORY AND TARGETS.....	25
1.5	DRILLING, SAMPLING AND DATA VERIFICATION.....	27
1.5.1	DRILLING.....	27
1.5.2	SAMPLING METHOD AND APPROACH.....	28
1.5.3	SAMPLE PREPARATION, ANALYSIS AND SECURITY.....	29
1.5.4	DATA VERIFICATION.....	29
1.6	MINERAL RESOURCE ESTIMATION AND HISTORY.....	31
1.7	MINING.....	34
1.7.1	OPEN PIT MINING.....	35
1.7.2	UNDERGROUND MINING.....	40
1.8	PROCESS.....	45
1.8.1	INTRODUCTION.....	45
1.8.2	COMMINUTION.....	46
1.8.3	METALLURGICAL TESTWORK.....	46
1.8.4	GEOMETALLURGY.....	47
1.8.5	PROCESS RECOVERIES.....	47
1.8.6	PROCESS DESIGN.....	48
1.8.7	TAILINGS.....	49
1.8.8	WASTE ROCK MANAGEMENT.....	52
1.8.9	CLOSURE.....	52
1.8.10	WATER MANAGEMENT.....	53
1.9	INFRASTRUCTURE.....	53
1.9.1	POWER GENERATION.....	55
1.9.2	PORT SITE.....	56
1.9.3	ACCESS ROAD.....	56

1.9.4	PIPELINES .....	57
1.10	SUSTAINABILITY .....	58
1.10.1	PROJECT PLANNING.....	58
1.10.2	STATE AND FEDERAL PERMITTING .....	58
1.10.3	KEY ENVIRONMENTAL ISSUES AND DESIGN DRIVERS.....	59
1.10.4	BASELINE STUDIES .....	60
1.10.5	SOCIO-POLITICAL ENVIRONMENT .....	61
1.10.6	STAKEHOLDER AND COMMUNITY RELATIONS .....	64
1.11	FINANCIAL AND COST ANALYSIS .....	66
1.11.1	KEY ECONOMIC ASSUMPTIONS.....	66
1.11.2	CAPITAL COST ESTIMATES .....	70
1.11.3	OPERATING COST ESTIMATE.....	73
1.11.4	CASH COST.....	74
1.11.5	NET SMELTER RETURN .....	75
1.11.6	PROJECT CASH FLOWS .....	75
1.11.7	PEBBLE PROJECT FINANCIAL RESULTS .....	76
1.11.8	NORTHERN DYNASTY ALLOCATION .....	77
1.11.9	NPV <sub>7</sub> AND METAL PRICE SENSITIVITIES .....	78
1.11.10	IRR AND METAL PRICE SENSITIVITIES .....	80
1.12	RECOMMENDATIONS AND OPPORTUNITIES .....	81
1.12.1	RESOURCE .....	81
1.12.2	MINING.....	81
1.12.3	PROCESS .....	82
1.12.4	INFRASTRUCTURE .....	83
1.12.5	PROJECT EXECUTION AND OPERATION .....	84
1.12.6	COSTS .....	84
1.12.7	CAPITAL COST .....	85
1.12.8	FINANCIAL ANALYSIS.....	85
<b>2.0</b>	<b>INTRODUCTION .....</b>	<b>86</b>
2.1	GENERAL.....	86
2.2	UNITS OF MEASUREMENT .....	88
2.3	SOURCES OF INFORMATION.....	88
<b>3.0</b>	<b>RELIANCE ON OTHER EXPERTS.....</b>	<b>89</b>
<b>4.0</b>	<b>PROPERTY DESCRIPTION AND LOCATION .....</b>	<b>90</b>
4.1	LOCATION.....	90
4.2	DESCRIPTION.....	91
4.3	SURFACE RIGHTS .....	97
4.4	ENVIRONMENTAL LIABILITIES .....	97
4.5	PERMITS.....	97
4.6	OWNERSHIP HISTORY .....	97
<b>5.0</b>	<b>ACCESSIBILITY, CLIMATE, LOCAL RESOURCES, INFRASTRUCTURE AND PHYSIOGRAPHY.....</b>	<b>100</b>
5.1	ACCESSIBILITY .....	100

5.2	CLIMATE .....	100
5.3	INFRASTRUCTURE .....	100
5.4	LOCAL RESOURCES .....	101
5.5	PHYSIOGRAPHY .....	101
<b>6.0</b>	<b>HISTORY.....</b>	<b>102</b>
6.1	HISTORICAL RESOURCE ESTIMATES .....	103
<b>7.0</b>	<b>GEOLOGICAL SETTING.....</b>	<b>104</b>
7.1	REGIONAL GEOLOGY.....	104
7.2	DEPOSIT GEOLOGY.....	107
7.2.1	SEDIMENTARY ROCKS.....	109
7.2.2	PLUTONIC ROCKS .....	109
7.2.3	COVER SEQUENCE .....	110
7.2.4	LATE MAGMATIC ROCKS .....	111
7.2.5	QUATERNARY GLACIAL SEDIMENTS .....	111
7.3	STRUCTURAL GEOLOGY .....	111
7.3.1	FOLDING.....	111
7.3.2	BRITTLE-DUCTILE DEFORMATION .....	111
7.3.3	BRITTLE FAULTS .....	116
7.3.4	TILTING OF THE DISTRICT .....	116
<b>8.0</b>	<b>DEPOSIT TYPES.....</b>	<b>117</b>
<b>9.0</b>	<b>MINERALIZATION.....</b>	<b>119</b>
9.1	HYDROTHERMAL ALTERATION .....	119
9.1.1	SUMMARY OF MAJOR ALTERATION TYPES.....	119
9.1.2	MAJOR VEIN TYPES .....	123
9.1.3	STYLES OF MINERALIZATION .....	126
9.1.4	OTHER MINERALIZED ZONES IN THE PEBBLE DISTRICT .....	129
<b>10.0</b>	<b>EXPLORATION.....</b>	<b>132</b>
10.1	OVERVIEW.....	132
10.1.1	GEOLOGICAL MAPPING .....	132
10.1.2	GEOPHYSICAL SURVEYS .....	132
10.1.3	GEOCHEMICAL SURVEYS.....	133
<b>11.0</b>	<b>DRILLING.....</b>	<b>134</b>
11.2	SUMMARY OF DRILLING 1988 TO 2010.....	135
11.3	THE 2010 DRILLING PROGRAM .....	139
11.3.1	DRILLING PROCEDURES, SURVEYS AND TYPES OF DRILLING IN 2010.....	140
11.3.2	RESULTS OF THE 2010 DRILLING PROGRAM .....	140
<b>12.0</b>	<b>SAMPLING METHOD AND APPROACH.....</b>	<b>141</b>
12.1	COMINCO DRILLING.....	141
12.2	NORTHERN DYNASTY 2002 DRILLING .....	142
12.3	NORTHERN DYNASTY 2003 DRILLING .....	142
12.4	NORTHERN DYNASTY 2004 DRILLING .....	142

12.5	NORTHERN DYNASTY 2005 DRILLING .....	143
12.6	NORTHERN DYNASTY 2006 DRILLING .....	143
12.7	NORTHERN DYNASTY AND THE PEBBLE PARTNERSHIP 2007 DRILLING .....	144
12.8	THE PEBBLE PARTNERSHIP 2008 DRILLING.....	145
12.9	THE PEBBLE PARTNERSHIP 2009 DRILLING.....	145
12.10	THE PEBBLE PARTNERSHIP 2010 DRILLING.....	146
<b>13.0</b>	<b>SAMPLE PREPARATION, ANALYSES AND SECURITY.....</b>	<b>147</b>
13.1	SAMPLE PREPARATION.....	147
13.2	ANALYSIS .....	148
<b>14.0</b>	<b>DATA VERIFICATION .....</b>	<b>151</b>
14.1	QUALITY ASSURANCE AND QUALITY CONTROL (QA/QC) .....	151
14.1.1	STANDARDS .....	152
14.1.2	DUPLICATES .....	153
14.1.3	BLANKS .....	155
14.1.4	QA/QC ON OTHER ELEMENTS.....	155
14.2	SPECIFIC GRAVITY (BULK DENSITY) DETERMINATIONS .....	155
14.2.1	DENSITY VALIDATION .....	156
14.3	SURVEY VALIDATION.....	157
14.4	DATA ENVIRONMENT .....	158
14.4.1	ERROR TRAPPING PROCESSES .....	159
14.4.2	ANALYSIS HIERARCHIES .....	160
14.4.3	WEDGES .....	160
14.4.4	CONTROL OF QA/QC.....	160
14.5	VERIFICATION .....	161
<b>15.0</b>	<b>ADJACENT PROPERTIES .....</b>	<b>163</b>
<b>16.0</b>	<b>MINERAL PROCESSING .....</b>	<b>164</b>
16.1	OVERVIEW.....	164
16.2	INTRODUCTION .....	164
16.3	MINERALOGY .....	164
16.4	METALLURGICAL TESTWORK DISCUSSION.....	167
16.4.1	PLANT FEED GRADE .....	167
16.4.2	ORE CHARACTERISTICS .....	168
16.4.3	FLOTATION TESTS .....	169
16.5	GOLD RECOVERY FROM PYRITE CONCENTRATE.....	173
16.6	PRIMARY GRIND SIZE.....	173
16.6.1	PRIMARY GRIND PARTICLE SIZE AND COPPER RECOVERY .....	173
16.7	FLOTATION TIME.....	174
16.7.1	HIGH PRESSURE GRINDING ROLLS PROCESS OPTION.....	175
16.8	METALLURGICAL TESTWORK RECOMMENDATIONS.....	175
16.9	PROCESS PLANT DESIGN .....	176
16.9.1	SUMMARY.....	176
16.9.2	MAJOR PROCESS DESIGN CRITERIA .....	177

16.9.3	PLANT DESIGN.....	178
16.9.4	PROCESS PLANT DESCRIPTION .....	178
16.10	PROCESS PLANT DESIGN DISCUSSION.....	187
16.10.1	PLANT AVAILABILITY.....	187
16.10.2	SURGE CAPACITY .....	187
16.10.3	GRINDING CIRCUIT DESIGN.....	187
16.10.4	GRINDING MEDIA CONSUMPTION .....	191
16.10.5	MILL LINER CONSUMPTION .....	191
16.10.6	FLOTATION .....	191
16.10.7	REGRIND CIRCUIT.....	193
16.10.8	1 <sup>ST</sup> CLEANER CIRCUIT .....	193
16.10.9	1 <sup>ST</sup> CLEANER SCAVENGER CIRCUIT .....	193
16.10.10	2 <sup>ND</sup> CLEANER CIRCUIT .....	194
16.10.11	2 <sup>ND</sup> CLEANER SCAVENGER CIRCUIT .....	194
16.10.12	MOLYBDENUM FLOTATION.....	194
16.10.13	MOLYBDENUM CONCENTRATE DRYING .....	194
16.11	THICKENING.....	194
16.11.1	BULK CONCENTRATE THICKENER .....	194
16.11.2	TAILINGS THICKENER .....	194
16.11.3	MOLYBDENUM CONCENTRATE THICKENER.....	195
16.11.4	MINE SITE – COPPER CONCENTRATE THICKENER .....	195
16.11.5	PORT SITE – COPPER CONCENTRATE THICKENER .....	196
16.11.6	COPPER CONCENTRATE FILTRATION AND STORAGE.....	196
16.11.7	GRAVITY CONCENTRATION OF GOLD .....	196
16.12	PROCESS PLANT DESIGN RECOMMENDATIONS .....	196
16.13	SIMPLIFIED PROCESS FLOWSHEETS .....	196
<b>17.0</b>	<b>MINERAL RESOURCE AND MINERAL RESERVE ESTIMATES.....</b>	<b>210</b>
17.1	SUMMARY AND RESOURCE DECLARATION.....	210
17.2	DOMAINS OF THE PEBBLE DEPOSIT.....	211
17.2.1	COPPER.....	212
17.2.2	GOLD .....	213
17.2.3	MOLYBDENUM .....	214
17.3	EXPLORATORY DATA ANALYSIS .....	215
17.3.1	DATA CLUSTERING.....	220
17.3.2	ASSAYS.....	221
17.3.3	OUTLIER MANAGEMENT AND CAPPING STRATEGY .....	221
17.3.4	COMPOSITES.....	224
17.4	BULK DENSITY .....	224
17.5	GEOLOGICAL INTERPRETATION.....	227
17.6	SPATIAL ANALYSIS – VARIOGRAPHY.....	227
17.7	RESOURCE BLOCK MODEL .....	231
17.8	INTERPOLATION PLAN .....	231
17.9	MINERAL RESOURCE CLASSIFICATION .....	233
17.10	MINERAL RESOURCE TABULATION .....	234
17.11	BLOCK MODEL VALIDATION .....	236

17.11.1	INTRODUCTION .....	236
17.11.2	COMPARATIVE BLOCK STATISTICS.....	237
17.11.3	SWATHS PLOTS .....	254
17.11.4	ORDINARY KRIGING SENSITIVITY ANALYSIS.....	260
17.12	RECOMMENDATIONS .....	263
17.12.1	SPECIFIC GRAVITY .....	263
17.12.2	CAPPING AND OUTLIER MANAGEMENT .....	263
17.12.3	VARIOGRAPHY .....	263
17.12.4	MOLYBDENUM DOMAIN 45 .....	264
17.12.5	BLOCK SIZE OPTIMIZATION.....	264
17.12.6	QUANTITATIVE KRIGING NEIGHBOURHOOD ANALYSIS .....	265
17.12.7	SYN-MINERALIZATION MODEL RECONSTRUCTION .....	267
17.12.8	KRIGING EFFICIENCY AND SLOPE OF REGRESSION.....	267
17.12.9	RISK ANALYSIS AND CONDITIONAL SIMULATION.....	267
<b>18.0</b>	<b>OTHER RELEVANT DATA AND INFORMATION .....</b>	<b>270</b>
18.1	MINING .....	270
18.1.1	OPEN PIT MINING .....	272
18.1.2	UNDERGROUND MINE PLANNING <sup>13</sup> .....	291
18.2	INFRASTRUCTURE .....	308
18.2.1	INTRODUCTION .....	308
18.2.2	SITE CONDITIONS .....	308
18.2.3	DESIGN CRITERIA .....	311
18.2.4	MINE SITE .....	312
18.2.5	SITE MOBILE EQUIPMENT .....	313
18.2.6	POWER GENERATION AND DISTRIBUTION.....	315
18.2.7	POWER DISTRIBUTION.....	320
18.2.8	EMERGENCY POWER .....	321
18.2.9	PORT SITE.....	322
18.2.10	MAIN ACCESS ROAD .....	325
18.2.11	CONCENTRATE, RECLAIM WATER AND DIESEL SUPPLY PIPELINES .....	333
18.2.12	VEHICLE MAINTENANCE .....	338
18.2.13	ADMINISTRATION BUILDING .....	340
18.2.14	CONSTRUCTION (CAMP, POWER, WATER AND SEWAGE) .....	341
18.2.15	MAIN WAREHOUSE .....	343
18.2.16	MILL SHOPS .....	343
18.2.17	MEDICAL/FIRST AID .....	344
18.2.18	COLD STORAGE BUILDING.....	344
18.2.19	UTILIDORS .....	344
18.2.20	WATER SYSTEMS.....	344
18.2.21	SOLID WASTE DISPOSAL .....	345
18.2.22	COMMUNICATIONS .....	347
18.2.23	UTILITIES AND SERVICES.....	347
18.3	TAILINGS, WASTE ROCK AND WATER MANAGEMENT .....	349
18.3.1	INTRODUCTION .....	349
18.3.2	SITE CHARACTERIZATION.....	349
18.3.3	TAILINGS AND WASTE ROCK CHARACTERISTICS.....	353
18.3.4	TAILINGS IMPOUNDMENT DESIGN AND CONSTRUCTION.....	353
18.3.5	TAILINGS PIPEWORKS .....	360

18.3.6	WASTE ROCK MANAGEMENT .....	360
18.3.7	CLOSURE CONSIDERATIONS.....	361
18.3.8	CAPITAL AND OPERATING COST ESTIMATE FOR TSF AND RELATED INFRASTRUCTURE .....	361
18.3.9	SUMMARY.....	361
18.3.10	MINE SITE WATER MANAGEMENT .....	362
18.4	SUSTAINABILITY .....	373
18.4.1	PROJECT SETTING.....	373
18.4.2	PROJECT PERMITTING.....	381
18.4.3	KEY ENVIRONMENTAL ISSUES AND DESIGN DRIVERS.....	387
18.4.4	BASELINE STUDIES .....	388
18.4.5	ENVIRONMENTAL ANALYSES AND INPUT TO PROJECT DESIGN.....	405
18.4.6	CONCEPTUAL MINE RECLAMATION AND CLOSURE PLAN .....	409
18.4.7	SOCIOPOLITICAL ENVIRONMENT .....	411
18.4.8	STAKEHOLDER AND COMMUNITY RELATIONS .....	420
18.5	CAPITAL COST ESTIMATE .....	427
18.5.1	SUMMARY.....	427
18.5.2	CURRENCY EXCHANGE AND OTHER RATES.....	428
18.5.3	ESTIMATE RESPONSIBILITY .....	428
18.5.4	WORK BREAKDOWN STRUCTURE AND DEFINITION SUMMARY .....	429
18.5.5	CONSTRUCTION SCHEDULE.....	432
18.5.6	CONSTRUCTION LABOUR HOURS AND COSTS .....	433
18.5.7	INDIRECT COST ESTIMATE.....	445
18.5.8	CAPITAL EXPENDITURE PHASING.....	446
18.5.9	ASSUMPTIONS AND EXCLUSIONS .....	447
18.5.10	SUSTAINING CAPITAL .....	448
18.5.11	MINE CLOSURE.....	449
18.6	OPERATING COST ESTIMATE .....	450
18.6.1	SUMMARY.....	450
18.6.2	SCOPE OF WORK.....	451
18.6.3	BASIS OF ESTIMATE .....	451
18.6.4	OPEN PIT MINING .....	454
18.6.5	PROCESS .....	455
18.6.6	TAILINGS FACILITY .....	455
18.6.7	ENVIRONMENTAL MANAGEMENT COSTS.....	456
18.6.8	WATER TREATMENT PLANT .....	457
18.6.9	TRANSPORTATION.....	457
18.6.10	GENERAL AND ADMINISTRATION .....	458
18.7	PROJECT EXECUTION PLAN.....	460
18.7.1	INTRODUCTION .....	460
18.7.2	HEALTH, SAFETY AND ENVIRONMENT .....	460
18.7.3	EXECUTION STRATEGY .....	461
18.7.4	ENGINEERING .....	462
18.7.5	PROCUREMENT AND CONTRACTS .....	462
18.7.6	CONSTRUCTION CAMP .....	464
18.7.7	MINE/MILL SITE CONSTRUCTION EXECUTION .....	464
18.8	FINANCIAL ANALYSIS.....	467
18.8.1	SUMMARY.....	467

18.8.2	BASIS FOR ANALYSIS .....	472
18.8.3	45-YEAR REFERENCE CASE MINE PLAN .....	481
18.8.4	25-YEAR IDC CASE.....	491
18.8.5	78-YEAR RESOURCE CASE .....	501
<b>19.0</b>	<b>INTERPRETATION AND CONCLUSIONS .....</b>	<b>514</b>
<b>20.0</b>	<b>OPPORTUNITIES AND RECOMMENDATIONS .....</b>	<b>518</b>
20.1	RESOURCE .....	518
20.1.1	EASTERN EXTENSION .....	518
20.1.2	ADDITIONAL DEPOSITS .....	518
20.1.3	SILVER .....	518
20.2	MINING.....	518
20.2.1	GENERAL .....	518
20.2.2	OPEN PIT .....	519
20.2.3	UNDERGROUND .....	519
20.3	PROCESS .....	519
20.3.1	AUTOMATION.....	519
20.3.2	SAG MILL SIZE.....	520
20.3.3	GOLD RECOVERY .....	520
20.3.4	GRINDING CIRCUIT.....	520
20.3.5	PRODUCTION INCREASE.....	520
20.4	INFRASTRUCTURE .....	520
20.4.1	PORT .....	520
20.4.2	OTHER OUTSOURCING OPPORTUNITIES.....	520
20.5	PROJECT EXECUTION AND OPERATION .....	521
20.5.1	DEVELOPMENT SCHEDULE .....	521
20.5.2	CONSTRUCTION CASH FLOW.....	521
20.5.3	RAMP-UP.....	521
20.5.4	SUSTAINING CAPITAL .....	521
20.6	COSTS.....	522
20.6.1	COST ESCALATION.....	522
20.6.2	CONTINGENCY .....	522
20.6.3	CAPITAL COST .....	522
20.6.4	POWER .....	522
20.7	FINANCIAL ANALYSIS.....	522
20.7.1	REAL OPTIONS .....	522
20.7.2	PRECIOUS METAL STREAMING .....	523
<b>21.0</b>	<b>REFERENCES .....</b>	<b>524</b>
21.1	GEOLOGY .....	524
21.2	MINERAL PROCESSING.....	525
21.3	TAILINGS .....	526
21.4	MINING.....	526
21.5	ADDED BY CLIENT .....	527
<b>22.0</b>	<b>DATE AND SIGNATURE PAGE.....</b>	<b>528</b>



## LIST OF TABLES

---

Table 1.1.1	Pebble Project – Summary of Production Results – All Cases .....	11
Table 1.1.2	Pebble Project – Metal Price Assumptions .....	12
Table 1.1.3	Pebble Project – Summary Financial Results – All Cases .....	13
Table 1.1.4	Northern Dynasty – Summary Financial Results – All Cases .....	14
Table 1.5.1	Summary of Drilling in the Pebble Region to October 2010 .....	27
Table 1.6.1	Current Pebble Project Resources (February, 2010) .....	32
Table 1.7.1	Main Equipment Requirements .....	37
Table 1.7.2	Operational Management Complement .....	38
Table 1.7.3	Operator and Maintenance Staff on Payroll .....	39
Table 1.7.4	Total Mining Operational Cost for 45 year Case .....	39
Table 1.7.5	Total Mining Operational Cost per Time Horizon .....	39
Table 1.7.6	Underground Mining Capital Cost Summary (US\$ millions) .....	44
Table 1.7.7	Underground Mining Unit Operating Cost Summary for Typical Full Production Year .....	45
Table 1.8.1	Life-of-Mine Process Recoveries .....	48
Table 1.11.1	Pebble Project – Key Economic Assumptions .....	67
Table 1.11.2	Pebble Project – Production Summary All Cases .....	67
Table 1.11.3	Pebble Project – Copper-Gold Concentrate Statistics – All Cases .....	69
Table 1.11.4	Pebble Project – Molybdenum Concentrate Statistics – All Cases .....	70
Table 1.11.5	Pebble Project – Initial Capital – All Cases .....	71
Table 1.11.6	Pebble Project – Sustaining Capital Costs (\$M) – All Cases .....	72
Table 1.11.7	Pebble Project – Operating Cost – All Cases .....	73
Table 1.11.8	Pebble Project – Operating Cost Per Ton – 45-Year Reference Case .....	74
Table 1.11.9	Operating Personnel .....	74
Table 1.11.10	Pebble Project – Cash Costs – All Cases .....	74
Table 1.11.11	Pebble Project – Net Smelter Return – All Cases .....	75
Table 1.11.12	Pebble Project – Summary Financial Results – All Cases .....	77
Table 1.11.13	Northern Dynasty Pre- and Post-Tax Financial Results .....	78
Table 1.11.14	Northern Dynasty Project – Post-Tax NPV <sub>7</sub> Sensitivities – All Cases .....	79
Table 1.11.15	Northern Dynasty – Post-Tax IRR Sensitivities – All Cases .....	80
Table 2.1.1	Summary of Qualified Persons .....	87
Table 4.2.1	Pebble Mineral Claims .....	93
Table 6.1.1	Cominco Drilling on Sill Prospect to End of 1997 .....	102
Table 6.1.2	Cominco Drilling on Pebble Deposit to the End of 1997 .....	102
Table 6.1.3	Total Cominco Drilling on Pebble Property to the End of 1997 .....	103
Table 6.1.1	Cominco Resource Estimates .....	103
Table 11.2.1	Summary of Drilling in the Pebble District to December 2010 .....	137
Table 11.3.1	Drilling in the Pebble Deposit during 2010 .....	140
Table 14.1.1	QA/QC Sample Types Used .....	151
Table 14.2.1	Summary of All Density Results .....	156
Table 14.2.2	Summary of All Density Results Used for Resource Estimation .....	156
Table 14.4.1	Drill Hole Database Summary .....	158
Table 14.4.2	Drill Hole Database Summary Used for Resource Estimation .....	159
Table 16.3.1	Gold Department in Pyrite Concentrates .....	166
Table 16.3.2	Summary of Gold Grains Observed in the Six Cleaner Scavenger Tailings Samples .....	166

Table 16.4.1	Comparison of Feed Grades – Mine Plan and Process Design Criteria .....	167
Table 16.4.2	Sample Feed Assays .....	168
Table 16.4.3	Crushing and Grinding Data .....	168
Table 16.5.1	Bottle Roll Test Results .....	173
Table 16.6.1	Effect of Primary Grind on the Recoveries of Copper, Gold, and Molybdenum .....	173
Table 16.6.2	Average Increase in Recovery per 10 µm Primary Grind Reduction .....	174
Table 16.7.1	Recommended Flotation Retention Time .....	174
Table 16.9.1	Major Process Design Criteria .....	178
Table 16.10.1	Grinding Circuit Design Parameters .....	188
Table 16.10.2	Grinding Circuit Simulation Criteria .....	188
Table 16.10.3	Simulation Throughput Comparison Data .....	189
Table 16.10.4	Summary of SABC-A and SABC-B Grinding Circuits .....	190
Table 16.10.5	Selected Flotation Design Parameters .....	191
Table 16.11.1	Results of Tailings Thickening Tests .....	195
Table 16.11.2	Tailings Thickener Parameters .....	195
Table 16.11.3	Copper Concentrate Thickening Parameters .....	195
Table 16.13.1	Mass Balance .....	197
Table 17.1.1	February 2010 Mineral Resource Estimate* .....	210
Table 17.2.1	Copper Domain Codes .....	212
Table 17.2.2	Gold Domain Codes .....	213
Table 17.2.3	Molybdenum Domain Codes .....	214
Table 17.3.1	Descriptive Statistics for Drill Hole and Block Model Data with Respect to Copper Domains in the Pebble Deposit .....	216
Table 17.3.2	Descriptive Statistics for Drill Hole and Block Model Data with Respect to Gold Domains in the Pebble Deposit .....	217
Table 17.3.3	Descriptive Statistics for Drill Hole and Block Model Data with Respect to Molybdenum Domains in the Pebble Deposit .....	218
Table 17.3.4	Top Cuts .....	222
Table 17.4.1	Statistics for Density (Specific Gravity) for Domains (SGZONE) 1, 2, and 3 .....	225
Table 17.7.1	Block Model Geometry .....	231
Table 17.8.1	Domain Boundaries – “Hard” vs. “Soft” Divisions .....	232
Table 17.8.2	Search Parameters Adopted for Estimation .....	232
Table 17.10.1	November 2010 Mineral Resource Estimate* .....	235
Table 17.11.1	Block Statistics by Domain for Copper .....	238
Table 17.11.2	Block Statistics by Domain for Gold .....	239
Table 17.11.3	Block Statistics by Domain for Molybdenum .....	240
Table 17.11.4	Block Statistics for Specific Gravity by Domain .....	241
Table 17.11.5	Variogram Model Variance with Respect to Total Variance of the Corresponding Sample Data (Normalized to One) .....	260
Table 17.11.6	Comparison between Two Ordinary Kriged Block Models as Percentage Difference* .....	261
Table 17.12.1	Search and Sample Optimization (QKNA) .....	266
Table 17.12.2	Preliminary (copper) Confidence Limits Calculations for the Pebble Deposit .....	268
Table 18.1.1	Recommended Bench Face Angle and Inter-Ramp Angle Domains .....	275
Table 18.1.2	Pit Optimization Parameters .....	276
Table 18.1.3	Incremental Open Pit Phase Volumes Based on a Cut-off of 0.2%Cu .....	279
Table 18.1.4	Cumulative Open Pit Phase Volumes Based on a Cut-off of 0.2%Cu .....	280
Table 18.1.5	Assumed Autonomous Trucking Improvements .....	281
Table 18.1.6	Haulage Profile Speeds and Fuel Consumption by Section .....	282

Table 18.1.7	Sample Drill Productivity Calculations .....	283
Table 18.1.8	Sample Basic Blasting Calculations .....	283
Table 18.1.9	Sample Loading Productivity Calculations .....	284
Table 18.1.10	Main Equipment Requirements .....	286
Table 18.1.11	Ancillary Equipment Requirement .....	286
Table 18.1.12	Support Equipment Requirements .....	287
Table 18.1.13	Estimated Life of Equipment .....	287
Table 18.1.14	Estimated Mine Equipment Capital Costs .....	288
Table 18.1.15	Life-of-mine Capital Estimate for Mine Equipment.....	289
Table 18.1.16	Operating Cost Categories .....	290
Table 18.1.17	Operational Management Complement .....	290
Table 18.1.18	Operator and Maintenance Staff on Payroll .....	290
Table 18.1.19	Total Mining Operating Cost for 45-Year Reference Case .....	291
Table 18.1.20	Total Mining Operating Cost per Time Horizon .....	291
Table 18.1.21	Underground Mining NSR Inputs .....	300
Table 18.1.22	Pre-Production Milestone Summary.....	302
Table 18.1.23	Underground Production Schedule Summary.....	303
Table 18.1.24	Underground Capital Cost Summary (US\$ millions).....	305
Table 18.1.25	Unit Operating Cost Summary for Typical Full Production Year .....	306
Table 18.1.26	Annual Expenditure Schedule .....	307
Table 18.2.1	Plant and Service Mobile Equipment .....	313
Table 18.2.2	Site Parameters and Design Operating Conditions for Power Plant.....	317
Table 18.2.3	Heat Balance .....	318
Table 18.2.4	Natural Gas Pipeline Details .....	320
Table 18.2.5	Preliminary Average Power Demand (MW) .....	320
Table 18.2.6	Design Vessel.....	324
Table 18.3.1	Capital Cost for TSF and Associated Infrastructure .....	361
Table 18.3.2	Upper Bench Open Pit Dewatering– Annual Average Pumping Requirements .....	365
Table 18.3.3	Pit Bottom Open Pit Dewatering – Annual Average and Peak Pumping Requirements .....	365
Table 18.3.4	Industrial Wastewater Discharge Permit Limitations for Freshwater Discharge .....	369
Table 18.4.1	Pebble Project Permits .....	383
Table 18.4.2	Environmental Baseline Study Consultants .....	390
Table 18.4.3	Environmental Baseline Document Table of Contents (Page 1 of 2).....	391
Table 18.4.4	Summary of Groundwater Investigations .....	397
Table 18.4.5	Summary of Piezometer Investigations.....	397
Table 18.4.6	Industrial Wastewater Discharge Permit Limitations for Freshwater Discharge .....	406
Table 18.4.7	Project Risks and PLP Planning and Management .....	408
Table 18.4.8	Bristol Bay ANCSA Village Corporations and Villages Represented .....	415
Table 18.5.1	Capital Cost Summary by Phase .....	428
Table 18.5.2	Work Breakdown Structure (WBS).....	429
Table 18.5.3	WBS by Phase .....	429
Table 18.5.4	WBS by Facility .....	431
Table 18.5.5	WBS by Job Code .....	431
Table 18.5.6	Project Schedule Significant Milestones .....	432
Table 18.5.7	Contractor Labour Rates .....	434
Table 18.5.8	Labour Productivity Factors.....	434

Table 18.5.9	Open Pit Mining Equipment Unit Costs .....	435
Table 18.5.10	Major Equipment Re-Priced .....	438
Table 18.5.11	Material Cost Source .....	439
Table 18.5.12	Currency Cost Source – Materials .....	439
Table 18.5.13	Construction Equipment Rental Costs .....	443
Table 18.5.14	Pebble Project – Sustaining Capital Costs (\$M) – All Cases .....	449
Table 18.6.1	Operating Cost Estimate – 45-Year Reference Case (LOM Average) .....	450
Table 18.6.2	Operating Cost Estimate – 45-Year Reference Case (LOM Average) .....	450
Table 18.6.3	Number of Employees on Payroll.....	451
Table 18.6.4	Labour Rates – Annual Loaded Salary with Bonus, Rounded .....	453
Table 18.6.5	Open Pit Mining Cost per Ton .....	454
Table 18.6.6	Mine Management Component .....	455
Table 18.6.7	Open Pit Operator and Maintenance Staffing .....	455
Table 18.6.8	Process Cost per Ton Milled .....	455
Table 18.6.9	Labour and Materials Proportions for Tailings Maintenance Costs .....	456
Table 18.6.10	Overall WTP Costs (LOM average).....	457
Table 18.6.11	Representative Material Transport Costs.....	457
Table 18.6.12	Assumptions for Other G&A Costs.....	459
Table 18.7.1	Key Milestone Schedule.....	462
Table 18.8.1	Pebble Project Results – Summary.....	467
Table 18.8.2	Long-term Metal Prices .....	468
Table 18.8.3	Current Prevailing Metal Prices.....	469
Table 18.8.4	Pebble Project Financial Results – Current Prevailing Metal Prices.....	469
Table 18.8.5	Northern Dynasty Financial Results at Long-term Metal Prices.....	472
Table 18.8.6	Northern Dynasty Financial Results at Current Prevailing Metal Prices .....	472
Table 18.8.7	Estimated Pebble Project Taxes – Long-term Metal Prices.....	474
Table 18.8.8	Estimated Pebble Project Taxes at Current Prevailing Metal Prices .....	474
Table 18.8.9	Pebble Project Post-tax Financial Results – All Cases .....	475
Table 18.8.10	Effective Income Tax Rates .....	476
Table 18.8.11	Smelter Terms .....	477
Table 18.8.12	Doré Terms.....	477
Table 18.8.13	Pebble Project – Initial Capital – All Cases .....	479
Table 18.8.14	Capital Cost Breakdown of Outsourced Infrastructure Assets .....	479
Table 18.8.15	Molybdenum Autoclave Specifications.....	480
Table 18.8.16	Project Results – 45-Year Reference Case .....	481
Table 18.8.17	Concentrate Statistics – 45-Year Reference Case .....	483
Table 18.8.18	Sustaining Capital Costs – 45-Year Reference Case .....	484
Table 18.8.19	Total Operating Costs – 45-Year Reference Case .....	484
Table 18.8.20	Offsite Charges – 45-Year Reference Case.....	484
Table 18.8.21	Net Smelter Return – 45-Year Reference Case.....	486
Table 18.8.22	Pre-Tax NPV <sub>7</sub> Metal Price Matrix – 45-Year Reference Case .....	489
Table 18.8.23	Pre-Tax IRR Metal Price Matrix – 45-Year Reference Case.....	489
Table 18.8.24	Post-Tax NPV <sub>7</sub> Metal Price Matrix – 45-Year Reference Case .....	490
Table 18.8.25	Post-Tax IRR Metal Price Matrix – 45-Year Reference Case .....	490
Table 18.8.26	Project Results – 25-Year IDC Case.....	491
Table 18.8.27	Concentrate Statistics – 25-Year IDC Case .....	493
Table 18.8.28	Sustaining Capital Costs – 25-Year IDC Case.....	494
Table 18.8.29	Total Operating Costs – 25-Year IDC Case .....	494
Table 18.8.30	Offsite Charges – 25-Year IDC Case .....	494
Table 18.8.31	Net Smelter Return – 25-Year IDC Case .....	496

Table 18.8.32	Pre-Tax NPV <sub>7</sub> Metal Price Matrix – 25-Year IDC Case.....	499
Table 18.8.33	Pre-Tax IRR Metal Price Matrix – 25-Year IDC Case .....	499
Table 18.8.34	Post-Tax NPV <sub>7</sub> Metal Price Matrix – 25-Year IDC Case.....	500
Table 18.8.35	Post-Tax IRR Metal Price Matrix – 25-Year IDC Case .....	500
Table 18.8.36	Project Results – 78-year Resource Case .....	501
Table 18.8.37	Concentrate Statistics – 78-year Resource Case .....	503
Table 18.8.38	Sustaining Capital Costs – 78-year Resource Case .....	504
Table 18.8.39	Total Operating Costs – 78-year Resource Case .....	504
Table 18.8.40	Offsite Charges – 78-year Resource Case .....	504
Table 18.8.41	Net Smelter Return – 78-year Resource Case .....	506
Table 18.8.42	Pre-Tax NPV <sub>7</sub> Metal Price Matrix – 78-year Resource Case.....	509
Table 18.8.43	Pre-Tax IRR Metal Price Matrix – 78-year Resource Case .....	509
Table 18.8.44	Post-Tax NPV <sub>7</sub> Metal Price Matrix – 78-year Resource Case .....	510
Table 18.8.45	Post-Tax IRR Metal Price Matrix – 78-year Resource Case.....	510
Table 18.8.46	Pebble Project Summary by Time Periods at Long-Term Metal Prices – 78-Year Resource Case .....	511
Table 18.8.47	Pebble Project Cumulative Summary at Long-term Metal Prices – 78-Year Resource Case.....	512
Table 18.8.48	Pebble Project Summary by Time Periods at Current Prevailing Prices – 78-Year Resource Case .....	513
Table 18.8.49	Pebble Project Cumulative Summary at Current Prevailing Metal Prices – 78-Year Resource Case.....	513

## LIST OF FIGURES

---

Figure 1.1.1	Location Map for the Pebble Project .....	2
Figure 1.1.2	Vegetation and Topography of the Pebble Project .....	3
Figure 1.1.3	General Mine and Tailings Storage Facility Layout.....	7
Figure 1.1.4	Iliamna Airport .....	9
Figure 1.1.5	Transportation Corridor and Port Site 1 Location.....	9
Figure 1.1.6	Pebble Project – 45-year Reference Case Pre-Tax Cash Flows.....	15
Figure 1.1.7	Pebble Project – 45-year Reference Case Copper-Gold Concentrate Production .....	15
Figure 1.1.8	Pebble Project – 45-year Reference Case Gold in Doré Production .....	16
Figure 1.1.9	Pebble Project – 45-year Reference Case Molybdenum Concentrate Production .....	16
Figure 1.1.10	Pebble Project – 45-year Reference Case Tons Milled and Strip Ratio .....	17
Figure 1.2.1	Pebble Project Location – Southwest Alaska.....	18
Figure 1.2.2	Drill Rig over the Pebble Deposit .....	18
Figure 1.3.1	Pebble Property Claim Map .....	20
Figure 1.4.1	District Geology of the Pebble Project.....	22
Figure 1.4.2	Pebble Deposit East-West Cross Section.....	22
Figure 1.4.3	Plan View of Relative Mineralization Concentration of the Pebble Deposit (Grade Calculated as CuEQ) .....	24
Figure 1.4.4	Cross-section A-A' of Pebble Deposit Showing Grade as CuEQ.....	24
Figure 1.4.5	East-West Section across DDH 6348 .....	25
Figure 1.4.6	Pebble Property Mineral Occurrences and IP Map.....	26

Figure 1.5.1	Location of Drill Holes – Pebble Region.....	28
Figure 1.5.2	Location of Drill Holes – Pebble Deposit Area .....	31
Figure 1.7.1	Pit Shells for All Development Cases.....	34
Figure 1.7.2	Cross Section Showing Open Pit Phase Sequence.....	35
Figure 1.7.3	Open Pit Phase Sequence at 0 ft amsl .....	36
Figure 1.7.4	Conceptual Underground Mining Block Layout – Plan View.....	41
Figure 1.7.5	Section A-A' through the Conceptual Mine Block Layout.....	41
Figure 1.7.6	Underground Mine Design Schematic – Plan View .....	42
Figure 1.8.1	Simplified Process Flowsheet .....	49
Figure 1.8.2	Typical North Embankment Section .....	51
Figure 1.9.1	Port Site 1 Layout.....	55
Figure 1.9.2	Pebble Project Transportation Corridor.....	57
Figure 1.10.1	General Pebble Project Study Areas.....	61
Figure 1.10.2	Boroughs and Settlements of Southwest Alaska .....	62
Figure 1.10.3	Alaska Village Corporation Lands in Southwest Alaska.....	63
Figure 1.10.4	General Land Status in the Pebble Project Area .....	64
Figure 1.11.1	Pebble Project – 45-Year Reference Case Tons Milled and Strip Ratio.....	68
Figure 1.11.2	Pebble Project – 45-Year Reference Case Copper-Gold Concentrate Production .....	69
Figure 1.11.3	Pebble Project – 45-Year Reference Case Molybdenum Concentrate Content.....	70
Figure 1.11.4	Pebble Project – Initial Capital Phasing – All Cases .....	72
Figure 1.11.5	Pebble Project – Sustaining Capital Phasing – All Cases.....	73
Figure 1.11.6	Cash Cost – 45-Year Reference Case.....	75
Figure 1.11.7	Pebble Project – 45-Year Reference Case Pre-Tax Cash Flows (\$M).....	76
Figure 4.1.1	Location Map for the Pebble Project .....	90
Figure 4.1.2	Location Map of the Pebble Deposit Relative to Southwest Alaska, showing Cook Inlet and Lake Iliamna.....	91
Figure 4.2.1	Mineral Claim Map – Pebble Project .....	92
Figure 7.1.1	Regional Solid Geology of the Western Southwest Cook Inlet Area .....	105
Figure 7.1.2	District Geology of the Pebble Deposit Showing the Major Lithological Units and Relative Ages .....	107
Figure 7.2.1	Interpreted Solid Geology of the Pebble District Based on Surface Exposures and Drill Intersections.....	108
Figure 7.3.1	Interpreted Cretaceous Geology of the Pebble Deposit Showing Major Structural Features .....	112
Figure 7.3.2	Geological Cross-section (A-A') Looking North* .....	113
Figure 7.3.3	Geological Cross-section (B-B') through the Pebble West Zone, Looking Northwest* .....	114
Figure 7.3.4	Geological Cross-section through the Pebble East Zone (C-C'), Looking Northwest .....	115
Figure 8.1.1	Pebble Deposit Rank by Contained Copper.....	118
Figure 8.1.2	Pebble Deposit Rank by Contained Gold.....	118
Figure 9.1.1	Distribution of Alteration Types in the Pebble Deposit .....	120
Figure 9.1.2	Plan View of Relative Mineralization Concentration of the Pebble Deposit (Grade Calculated as CuEQ) .....	126
Figure 9.1.3	Cross-section A-A' of Pebble Deposit Showing Grade as CuEQ.....	127
Figure 9.1.4	Core Photo Showing Chalcopyrite and Bornite Mineralization.....	128
Figure 9.1.5	Core Photo Showing Chalcopyrite Mineralization .....	129
Figure 9.1.6	Cretaceous Mineralization and New Deposit Targets .....	131

Figure 11.1.1	Location of Drill Holes – Pebble Deposit District .....	134
Figure 11.2.1	Location of Drill Holes – Pebble Deposit Area .....	136
Figure 13.2.1	Pebble Project 2010 Drill Core Sampling and Analytical Flow Chart .....	150
Figure 14.1.1	Performance of the Copper Standard CGS-16 in 2008 .....	152
Figure 14.1.2	Performance of the Gold Standard CGS-16 in 2008 .....	152
Figure 14.1.3	Comparison of Gold Duplicate Assay Results for 2004-2010 .....	154
Figure 14.1.4	Comparison of Copper Duplicate Assay Results for 2005-2010 .....	154
Figure 16.4.1	Standard Bulk Flotation Flowsheet .....	170
Figure 16.13.1	Crushing Plant and Coarse Ore Stockpile Process Flowsheet .....	202
Figure 16.13.2	Grinding Process Flowsheet – Sheet 1 .....	203
Figure 16.13.3	Grinding Process Flowsheet – Sheet 2 .....	204
Figure 16.13.4	Bulk Rougher Flotation Process Flowsheet .....	205
Figure 16.13.5	1 <sup>st</sup> Cleaner Flotation Process Flowsheet .....	206
Figure 16.13.6	2 <sup>nd</sup> Cleaner Flotation Process Flowsheet .....	207
Figure 16.13.7	Copper Concentrate Process Flowsheet .....	208
Figure 16.13.8	Regrind Process Flowsheet .....	209
Figure 16.13.9	Tailings Handling and Reagent, Water, and Utility Systems Process Flowsheet .....	210
Figure 17.2.1	Copper Domains of the Pebble Block Model (West-East) at 2157000 ft North .....	213
Figure 17.2.2	Gold Domains of the Pebble Block Model (West-East) at 2157000 ft North .....	214
Figure 17.2.3	Molybdenum Domains (MOZONE) of the Pebble Block Model (West-East) at 2157000 ft North .....	215
Figure 17.3.1	Histograms for Copper (CUZONE 2) – Raw Data and Compositing Data .....	219
Figure 17.3.2	Plan View of Pebble Deposit at 850 ft Elevation .....	220
Figure 17.3.3	Results of Declustering Grid Optimization Study .....	221
Figure 17.3.4	Histograms of Raw Data of Molybdenum Domains with Capped Values .....	223
Figure 17.4.1	West-East Section through the Deposit at 2157000 ft North Showing Density Data as 10-ft Long Sections .....	225
Figure 17.4.2	Representative Histograms of Density Data for SGZONE 2 and SGZONE 3 .....	226
Figure 17.6.1	Downhole and Major Axis Experimental and Modelled Variography for Copper Domain 42 .....	229
Figure 17.6.2	Experimental and Modelled Variography for Semi-major and Minor Axes for Copper Domain 42 .....	230
Figure 17.11.1	Ordinary Kriging Copper Section at 2156000 ft N with Corresponding Sample Data at ±150 ft Clipping Distance .....	242
Figure 17.11.2	Ordinary Kriging Copper Section at 2157000 ft N with Corresponding Sample Data at ±150 ft Clipping Distance .....	243
Figure 17.11.3	Ordinary Kriging Copper Section at 2158000 ft N with Corresponding Sample Data at ±150 ft Clipping Distance .....	244
Figure 17.11.4	Ordinary Kriging Gold Section at 2156000 ft N with Corresponding Sample Data at ±150 ft Clipping Distance .....	245
Figure 17.11.5	Ordinary Kriging Gold Section at 2157000 ft N with Corresponding Sample Data at ±150 ft Clipping Distance .....	246
Figure 17.11.6	Ordinary Kriging Gold Section at 2158000 ft N with Corresponding Sample Data at ±150 ft Clipping Distance .....	247
Figure 17.11.7	Ordinary Kriging Molybdenum Section at 2156000 ft N with Corresponding Sample Data at ±150 ft Clipping Distance .....	248
Figure 17.11.8	Ordinary Kriging Molybdenum Section at 2157000 ft N with Corresponding Sample Data at ±150 ft Clipping Distance .....	249

Figure 17.11.9	Ordinary Kriging Molybdenum Section at 2158000 ft N with Corresponding Sample Data at $\pm 150$ ft Clipping Distance.....	250
Figure 17.11.10	Ordinary Kriging Density (SG) Section at 2156000 ft N with Corresponding Sample Data at $\pm 150$ ft Clipping Distance.....	251
Figure 17.11.11	Ordinary Kriging Density (SG) Section at 2157000 ft N with Corresponding Sample Data at $\pm 150$ ft Clipping Distance.....	252
Figure 17.11.12	Ordinary Kriging Density (SG) Section at 2158000 ft N with Corresponding Sample Data at $\pm 150$ ft Clipping Distance.....	253
Figure 17.11.13	Copper Model Swaths Plot by Bench (Z).....	254
Figure 17.11.14	Copper Model Swaths Plot by Row (Y).....	254
Figure 17.11.15	Copper Model Swaths Plot by Column (X).....	255
Figure 17.11.16	Gold Model Swaths Plots by Bench (Z).....	255
Figure 17.11.17	Gold Model Swaths Plots by Row (Y).....	256
Figure 17.11.18	Gold Model Swaths Plots by Column (X).....	256
Figure 17.11.19	Molybdenum Model Grade Swaths Plot by Bench (Z).....	257
Figure 17.11.20	Molybdenum Grade Swaths Plot by Row (XZ by Y).....	257
Figure 17.11.21	Molybdenum Grade Swaths Plot by Column (YX by X).....	258
Figure 17.11.22	Specific Gravity Swath Plot by Bench (Z).....	258
Figure 17.11.23	Specific Gravity Swath Plot by Row (XZ by Y).....	259
Figure 17.11.24	Specific Gravity Swath Plot by Column (YZ by X).....	259
Figure 17.12.1	Change in Total Cu% Grade with Respect to Change in Model Block Size and Cut-off.....	264
Figure 17.12.2	Change in Total copper Metal Content with Respect to Change in Model Block Size and Cut-off.....	265
Figure 17.12.3	Gaussian Distribution.....	268
Figure 18.1.1	Pit Shells for the 25-Year IDC Case, the 45-Year Reference Case and the 78-Year Resource Case.....	271
Figure 18.1.2	Location of All Geotechnical Drill Holes and Seismic Lines – Pit Area.....	273
Figure 18.1.3	Location of All Test Pits.....	274
Figure 18.1.4	45-Year Pit Showing Geotechnical Domains.....	275
Figure 18.1.5	East-West Cross Section Showing Open Pit Phase Sequence.....	277
Figure 18.1.6	Open Pit Plan at 0 ft amsl – All Cases.....	277
Figure 18.1.7	Approximate Waste Dump Configuration.....	282
Figure 18.1.8	Position of IPCC at 400 ft Elevation.....	285
Figure 18.1.9	Conceptual Underground Mining Block Layout.....	292
Figure 18.1.10	Section A-A' through the Conceptual Mine Block Layout.....	293
Figure 18.1.11	Underground Mine Design Schematic.....	293
Figure 18.1.12	Typical Drawpoint Design.....	295
Figure 18.1.13	Typical Extraction Level.....	295
Figure 18.1.14	Haulage and Conveyor Layouts.....	296
Figure 18.1.15	Overall Ventilation Schematic.....	297
Figure 18.1.16	Ventilation Layout.....	297
Figure 18.1.17	Conveyor Schematic.....	299
Figure 18.1.18	Underground Production Schedule by Mining Block.....	303
Figure 18.2.1	Location Map of the Pebble Project.....	309
Figure 18.2.2	Topography of Pebble Mine Site.....	310
Figure 18.2.3	Port Site 1 Layout.....	323
Figure 18.2.4	Aerial Photo of Williamsport Boat Launch and Dredged Channel.....	325
Figure 18.2.5	Pebble Project Access Route Map.....	326
Figure 18.2.6	Pump Station Layout.....	334



Figure 18.2.7	Pipeline Trench Section.....	336
Figure 18.3.1	Schematic of Seepage Control Measures with the Grout Curtain Trench .....	355
Figure 18.3.2	Final Site Arrangement – 25-Year IDC Case .....	357
Figure 18.3.3	Typical North Embankment Section .....	358
Figure 18.3.4	Pre-Production Site-Wide Water Management Plan .....	363
Figure 18.3.5	Operations Site-Wide Water Management Plan .....	364
Figure 18.3.6	Water Balance Flows.....	367
Figure 18.3.7	Process Flow Block Diagram for Mine Water Treat System .....	372
Figure 18.4.1	Pebble Project Location – Southwest Alaska.....	374
Figure 18.4.2	Pebble Project Access Corridor .....	375
Figure 18.4.3	Pebble Deposit Area – Looking North .....	376
Figure 18.4.4	Pebble Site Topography – Looking Northwest.....	376
Figure 18.4.5	Pebble Site Topography – Looking East.....	377
Figure 18.4.6	Proposed Newhalen River Crossing Site – Looking Downstream to the South .....	377
Figure 18.4.7	Pedro Bay.....	378
Figure 18.4.8	Williamsport, Looking Inland to the West .....	378
Figure 18.4.9	Port Site 1, Looking Northeast into Iniskin Bay .....	379
Figure 18.4.10	Bristol Bay Watersheds .....	380
Figure 18.4.11	Typical Mining Project Flow Diagram .....	386
Figure 18.4.12	General Pebble Project Study Areas.....	389
Figure 18.4.13	Pebble Project Spatial Data Index.....	395
Figure 18.4.14	Continuous Hydrologic Gauging Stations.....	396
Figure 18.4.15	Daily Mean Flow in Deposit Area Streams with Life Stage Periods for Salmon .....	397
Figure 18.4.16	Pebble Project Area Water Quality Sampling Stations .....	399
Figure 18.4.17	Pebble Project Area Wetlands Study Areas.....	400
Figure 18.4.18	Fish Sampling Sites on the North Fork Koktuli River .....	401
Figure 18.4.19	Fish Sampling Sites on the South Fork Koktuli River.....	402
Figure 18.4.20	Fish Sampling Sites on Upper Talarik Creek .....	403
Figure 18.4.21	Fish Sampling Sites on the Koktuli River .....	404
Figure 18.4.22	Boroughs and Settlements of Southwest Alaska .....	412
Figure 18.4.23	Alaska Native Regional Corporations.....	414
Figure 18.4.24	Alaska Native Village Corporation Lands in Southwest Alaska .....	416
Figure 18.4.25	Alaska Native Village Corporation Lands in the Pebble Project Area.....	417
Figure 18.4.26	Bristol Bay Community Institutions Supportive of Permitting Process .....	426
Figure 18.5.1	Pebble Project – Initial Capital Phasing – All Cases .....	447
Figure 18.5.2	Pebble Project – 78-year Reference Case Sustaining Capital Phasing (\$M).....	449
Figure 18.8.1	Copper-Gold Concentrate Produced – 45-Year Reference Case.....	483
Figure 18.8.2	Cash Cost – 45-Year Reference Case.....	485
Figure 18.8.3	Revenue vs. Operating Costs – 45-Year Reference Case .....	486
Figure 18.8.4	Project Post-Tax Cash Flow – 45-Year Reference Case.....	487
Figure 18.8.5	Pre-Tax NPV <sub>7</sub> Sensitivity to Inputs – 45-Year Reference Case (\$B).....	488
Figure 18.8.6	Pre-Tax IRR Chart Sensitivity to Inputs – 45-Year Reference Case (%).....	488
Figure 18.8.7	Copper-Gold Concentrate Produced – 25-Year IDC Case .....	493
Figure 18.8.8	Cash Cost – 25-Year IDC Case .....	495
Figure 18.8.9	Revenue vs. Operating Costs – 25-Year IDC Case.....	496
Figure 18.8.10	Project Post-tax Cash Flow – 25-Year IDC Case (\$M) .....	497
Figure 18.8.11	Pre-Tax NPV <sub>7</sub> Sensitivity to Inputs – 25-Year IDC Case .....	498
Figure 18.8.12	Pre-Tax IRR Chart Sensitivity to Inputs – 25-Year IDC Case .....	498

Figure 18.8.13	Copper-Gold Concentrate Produced – 78-year Resource Case.....	503
Figure 18.8.14	Cash Cost – 78-year Resource Case.....	505
Figure 18.8.15	Revenue vs. Operating Costs – 78-year Resource Case .....	506
Figure 18.8.16	Project Post-tax Cash Flow – 78-year Resource Case (\$M) .....	507
Figure 18.8.17	Pre-Tax NPV <sub>7</sub> Sensitivity to Inputs – 78-year Resource Case.....	508
Figure 18.8.18	Pre-Tax IRR Chart Sensitivity to Inputs – 78-year Resource Case .....	508

## GLOSSARY

---

### UNITS OF MEASURE

Above mean sea level.....	amsl
Acre .....	ac
Ampere .....	A
Annum (year) .....	a
Billion .....	B
Billion tonnes.....	Bt
Billion years ago.....	Ga
British thermal unit .....	BTU
Centimetre .....	cm
Cubic centimetre .....	cm <sup>3</sup>
Cubic feet per minute.....	cfm
Cubic feet per second .....	ft <sup>3</sup> /s
Cubic foot.....	ft <sup>3</sup>
Cubic inch .....	in <sup>3</sup>
Cubic metre.....	m <sup>3</sup>
Cubic yard.....	yd <sup>3</sup>
Coefficients of Variation .....	CVs
Day .....	d
Days per week .....	d/wk
Days per year (annum) .....	d/a
Dead weight tonnes .....	DWT
Decibel adjusted .....	dBa
Decibel.....	dB
Degree .....	°
Degrees Celsius.....	°C
Diameter .....	∅
Dollar (American).....	US\$
Dollar (Canadian).....	Cdn\$
Dry metric ton.....	dmt
Foot.....	ft
Gallon .....	gal
Gallons per minute (US) .....	gpm

Gigajoule.....	GJ
Gigapascal.....	GPa
Gigawatt.....	GW
Gram.....	g
Grams per litre.....	g/L
Grams per tonne.....	g/t
Greater than.....	>
Hectare (10,000 m <sup>2</sup> ).....	ha
Hertz.....	Hz
Horsepower.....	hp
Hour.....	h
Hours per day.....	h/d
Hours per week.....	h/wk
Hours per year.....	h/a
Inch.....	"
Kilo (thousand).....	k
Kilogram.....	kg
Kilograms per cubic metre.....	kg/m <sup>3</sup>
Kilograms per hour.....	kg/h
Kilograms per square metre.....	kg/m <sup>2</sup>
Kilometre.....	km
Kilometres per hour.....	km/h
Kilopascal.....	kPa
Kilotonne.....	kt
Kilovolt.....	kV
Kilovolt-ampere.....	kVA
Kilovolts.....	kV
Kilowatt.....	kW
Kilowatt hour.....	kWh
Kilowatt hours per tonne (metric ton).....	kWh/t
Kilowatt hours per year.....	kWh/a
Less than.....	<
Litre.....	L
Litres per minute.....	L/m
Megabytes per second.....	Mb/s
Megapascal.....	MPa
Megavolt-ampere.....	MVA
Megawatt.....	MW
Metre.....	m
Metres above sea level.....	masl
Metres Baltic sea level.....	mbsl
Metres per minute.....	m/min
Metres per second.....	m/s
Metric ton (tonne).....	t
Microns.....	µm
micromhos per centimetre.....	umhos/cm

Milligram.....	mg
Milligrams per litre.....	mg/L
Millilitre.....	mL
Millimetre.....	mm
Million.....	M
Million bank cubic metres.....	Mbm <sup>3</sup>
Million bank cubic metres per annum.....	Mbm <sup>3</sup> /a
Million tonnes.....	Mt
Minute (plane angle).....	'
Minute (time).....	min
Month.....	mo
Ounce.....	oz
Parts per million.....	ppm
Parts per billion.....	ppb
Percent.....	%
Pound(s).....	lb
Pounds per square inch.....	psi
Revolutions per minute.....	rpm
Second (plane angle).....	"
Second (time).....	s
Specific gravity.....	SG
Square centimetre.....	cm <sup>2</sup>
Square foot.....	ft <sup>2</sup>
Square inch.....	in <sup>2</sup>
Square kilometre.....	km <sup>2</sup>
Square metre.....	m <sup>2</sup>
Thousand tonnes.....	kt
Three Dimensional.....	3D
Three Dimensional Model.....	3DM
Tonne (1,000 kg).....	t
Tonnes per day.....	t/d
Tonnes per hour.....	t/h
Tonnes per year.....	t/a
Tonnes seconds per hour metre cubed.....	ts/hm <sup>3</sup>
Volt.....	V
Week.....	wk
Weight/weight.....	w/w
Wet metric ton.....	wmt
Year (annum).....	a

**ABBREVIATIONS AND ACRONYMS**

Acme Analytical Laboratories .....	Acme
Alaska Department of Fish and Game .....	ADF&G
Alaska Department of Natural Resources Large Mine Permitting Team...	LMPT
Alaska Department of Transportation and Public Facilities .....	ADOT&PF
Alaska Mineral and Energy Resource Education Fund .....	AMEREF
Alaska Native Claims Settlement Act .....	ANCSA
Alaska Native Science and Engineering Program .....	ANSEP
ALS Minerals Laboratories .....	ALS
American Association of State Highway and Transportation Officials .....	AASHTO
Anglo American plc .....	Anglo American
Anglo American US .....	Anglo American US (Pebble) LLC
Aqua Regia .....	AR
Atomic Absorption Spectroscopy .....	AAS
Best Management Practices .....	BMPs
Bristol Bay Native Corporation .....	BBNC
Coarse Ore Storage Area .....	COS
Combined-Cycle Natural Gas-Fired Gas Turbine .....	CCGT
Cominco America Incorporated .....	Teck, Teck Cominco or Cominco
Cook Inlet Region, Inc. ....	CIRI
Department of Natural Resources .....	DNR
Digital Elevation Model .....	DEM\
Endangered Species Act .....	ESA
Engineering, Procurement and Construction Management .....	EPCM
Environmental and Social Impact Assessment .....	ESIA
Environmental Baseline Document .....	EBD
Environmental Impact Statement .....	EIS
Fire Assay .....	FA
FSS Canada Consultants Inc. ....	FSS
Hunter Dickinson Inc. ....	HDI
Hunter Dickinson Services Inc. ....	HDSI
In Pit Crushing and Conveying .....	IPCC
Independent Science Panel .....	ISP
Induced Polarization .....	IP
Inductively Coupled Plasma – Mass Spectroscopy Finish .....	ICP-MS
Internal Rate of Return .....	IRR
Investment Decision Case .....	IDC Case
Liquefied Natural Gas .....	LNG
Load Haul Dump .....	LHD
Local Area Network .....	LAN
Mass in Water .....	Mw
Microsoft® Access .....	Access
Multi Protocol Label Switching .....	MPLS
Multiple Indicator Kriging .....	MIK
National Environmental Policy Act .....	NEPA
National Instrument 43-101 .....	NI 43-101
Preliminary Assessment .....	PA
National Pollutant Discharge Elimination System .....	NPDES
Net Smelter Return .....	NSR
Net Present Value .....	NPV
Nicholson Analytical Consulting .....	NAC
Non-Acid Generating Waste Rock .....	NAG
Non-Potentially Acid Generating .....	NAG
Northern Dynasty Minerals Ltd .....	Northern Dynasty

Liberty Star, Big Chunk Corp. together .....	LS
Once-Through Steam Generator .....	OTSG
Ordinary Krige.....	OK
Pebble Copper-Gold-Molybdenum Project .....	Pebble Project
Pebble Limited Partnership.....	Pebble Partnership
Full Metal Minerals Corp. and Full Metal Minerals .....	FMM
Positive Displacement.....	PD
Potassium Ethyl Xanthate.....	PEX
Potentially Acid-Generating .....	PAG
Prevention of Significant Deterioration.....	PSD
Private Branch Exchange .....	PBX
Propylitic Alteration .....	PRP
Quality Assurance and Quality Control .....	QA/QC
Quartz-Sericite-Pyrite.....	QSP
Resource Conservation and Recovery Act .....	RCRA
Reverse Osmosis .....	RO
Rock Mass Rating.....	RMR
Roscoe Postle Associates Inc.....	RPA,
Run-of-mine .....	ROM
Semi-Autogenous Grinding.....	SAG
Sewage Treatment Plant .....	STP
SGS Mineral Services.....	SGS
Southwest Alaska Vocational Education Center .....	SAVEC
Supplemental Firing .....	SF
Tailings Storage Facility.....	TSF
U.S. Army Corps of Engineers.....	USACE
U.S. Geological Survey.....	USGS
Uniform Building Code.....	UBC
Variable-Frequency Drives .....	VFDs
Wardrop Engineering Inc.....	Wardrop
Water Treatment Plant.....	WTP
Wide Area Network.....	WAN
Z-Axis Tipper Electromagnetic Technique .....	ZTEM

## 1.0 EXECUTIVE SUMMARY

---

This Preliminary Assessment Technical Report of the Pebble Copper-Gold-Molybdenum Project (the “Pebble Project”) has been prepared by Wardrop Engineering Inc., a Tetra Tech Company (“Wardrop”) exclusively on behalf of Northern Dynasty Minerals Ltd. (“Northern Dynasty”). It is based on Wardrop’s technical review of recent engineering and technical studies undertaken by the Pebble Limited Partnership (the “Pebble Partnership”) and Northern Dynasty, as provided and verified by Northern Dynasty.

This Preliminary Assessment is an independent technical report of the Pebble Project. In accordance with its corporate responsibilities as a public company, Northern Dynasty has commissioned Wardrop to independently review and analyze project economics, current mineral resources and valuation estimates.

This Preliminary Assessment has been prepared independently from Anglo American plc (“Anglo American”) and the Pebble Partnership. It must be noted that the Pebble Partnership continues to undertake detailed engineering studies and project planning toward the completion of a Prefeasibility Study for the Pebble Project, and that no decision has been taken by the Pebble Partnership to seek permits for the project as described in this Preliminary Assessment. Recommendations within this Preliminary Assessment will be provided to the Pebble Partnership to guide further technical and engineering studies toward the completion of a Prefeasibility Study for the Pebble Project.

This Preliminary Assessment Technical Report conforms to the standards set out in National Instrument 43-101 (NI 43-101) and is in compliance with Form 43-101.

## 1.1 PROJECT OVERVIEW

---

Northern Dynasty is a mineral exploration and development company based in Vancouver, Canada, with indirect interests in 592 mi<sup>2</sup> of mineral claims in southwest Alaska, USA. Northern Dynasty’s principal asset is a 50% interest in the Pebble Limited Partnership, owner of the Pebble Copper-Gold-Molybdenum Project. The Pebble Project is an advanced-stage initiative to develop one of the most important mineral resources in the world.

The Pebble Project consists of the Pebble deposit, surrounding mineral claims and a stream of financing provided by Northern Dynasty’s project partner Anglo American US (Pebble) LLC (“Anglo American”). Funds provided by Anglo American are currently being invested in comprehensive exploration, engineering, environmental and socioeconomic programs toward the future development of the Pebble Project. Anglo American is required to elect to continue its staged investment of \$1.425 - \$1.5 billion to retain its 50% interest in the Pebble Partnership.

**Figure 1.1.1 Location Map for the Pebble Project**



**1.1.1 LAND STATUS AND PROJECT OWNERSHIP**

The Pebble Project is located on state land designated for mineral exploration and development in the Bristol Bay region of southwest Alaska. The property lies approximately 200 miles southwest of Anchorage, some 60 miles west of tidewater on Cook Inlet and 17 to 19 miles from the nearest communities of Iliamna, Newhalen and Nondalton. The deposit is situated approximately 1,000 ft amsl, in an area characterized by tundra, gently rolling hills and the absence of permafrost. Totalling 378,600 acres, Northern Dynasty’s indirect interests in the Pebble region forms a contiguous block consisting of 3,108 located Alaska State mineral claims.

Northern Dynasty secured its initial interest in the Pebble Project through an Alaskan subsidiary in 2001. That year, Northern Dynasty obtained an option to acquire up to a 100% interest in the Pebble property (consisting of the ‘Resource Lands’ that cover previously drilled areas of the Pebble deposit and surrounding ‘Exploration Lands’) from Cominco America Incorporated (“Teck,” “Teck Cominco” or “Cominco”) and a related party, the Hunter Dickinson Group Inc.



By 2006, Northern Dynasty had completed payments and work requirements to acquire its 100% interest in the 'Resource Lands' and the 'Exploration Lands', subject only to a net-profits interest held by Teck on the 'Exploration Lands.' Teck currently retains a 4% pre-payback net-profits interest and a 5% after-payback net profits interest on any mine development within the 'Exploration Lands' portion of the Pebble property only.

In July 2007, a wholly-owned affiliate of Northern Dynasty and a wholly owned subsidiary of Anglo American plc established the Pebble Partnership. In order to retain its 50% interest in the Pebble Partnership, Anglo American is required to elect to continue its staged investment of \$1.425 to \$1.5 billion to advance the Pebble Project toward permitting and operations. Both Northern Dynasty and Anglo American have equal and identical rights of management, operatorship and control in the Pebble Partnership.

To the end of 2010, Anglo American has invested some \$325 million of its \$1.425 to \$1.5 billion earn-in to engineer, permit, construct and operate a modern, long-life mine at Pebble.

**Figure 1.1.2 Vegetation and Topography of the Pebble Project**



### **1.1.2 PRELIMINARY ASSESSMENT DEVELOPMENT CASES**

This Preliminary Assessment presents an analysis of the potential economic value of the Pebble Project based on the most recent resource model and engineering completed to a conceptual, pre-feasibility and (in some cases) feasibility level of detail. Given the intensive technical, engineering, environmental, permitting and socioeconomic study programs undertaken in support of the Pebble Project since 2005, much of the analysis and supporting data in this Preliminary Assessment exceeds that often found in reports of this type.

While the mineral development project described in this Preliminary Assessment is considered to be economically viable, technically feasible and permissible under existing regulatory standards in Alaska and the United States, it must be noted that no decision has been taken by the Pebble Partnership to seek permits for the project as described. Each of the three successive development cases presented in this document is derived from engineering work conducted by the Pebble Partnership or Northern Dynasty; however, the project description that the Pebble Partnership ultimately elects to submit for permitting under the National Environmental Policy Act (NEPA) may vary in a number of ways.

As noted, this Preliminary Assessment describes and assigns potential economic value for three successive development cases:

1. The Investment Decision Case (“IDC Case”), which describes an initial 25-year open pit mine life upon which a decision to initiate mine permitting, construction and operations may be based;
2. The Reference Case, which is based on 45 years of open pit mine production; and
3. The Resource Case, which is based on 78 years of open pit mine production and seeks to assess the long-term value of the project in current dollars.

Phases of development beyond 25 years will require separate permitting and development decisions to be made in the future, based on prevailing conditions at the time and the accumulated experience gained from developing and operating the initial phase of the Pebble Project.

Of the three development cases, the 25-year IDC Case is the most comprehensively engineered. It seeks to mine near-surface ore for rapid payback, primarily in Measured and Indicated categories but also including a small proportion of Inferred material in the western portion of the Pebble deposit. Inferred resources comprise 16% of total ore mined. This initial phase of mining will process about two billion tons of ore or less than 20% of the total Pebble mineral resource. As such, it is not considered to be ideal for assessing the potential long-term economic value of the project.

*(It should be noted that Inferred mineral resources are considered to be too speculative to allow the application of technical and economic parameters to support mine planning and the evaluation of the economic viability of the project. As such, there is currently no certainty that development cases incorporating Inferred mineral resources can be realized).*

The level of engineering applied to the 45-year Reference Case is similar to that in the 25-year IDC Case, with the exception of detailed engineering associated with tailings storage after Year 25. This extended phase of mining will process a total of some 3.8 billion tons of ore (or 32% of the total Pebble mineral resource), primarily in Measured and Indicated categories in the western portion of the deposit. Inferred resources in the eastern portion of the deposit comprise 28% of the total ore mined.

Wardrop has selected the 45-year Reference Case as the base case for this Preliminary Assessment due to its enhanced level of development of the Pebble mineral resource within a timeframe that makes a significant contribution to the project’s Net Present Value (NPV).

*The valuation of the 45-year Reference Case for the Pebble Project, as presented in the Financial Analysis section of this Preliminary Assessment, yields a 14.2% pre-tax internal rate of return (IRR), a 6.2-year*

*payback on a \$4.7 billion capital investment and a \$6.1 billion pre-tax Net Present Value (NPV) at a 7% discount rate at long-term metal prices. At current prevailing metal prices, the 45-year Reference Case yields a 23.2% pre-tax IRR, a 3.2-year payback of initial capital investment and a \$15.7 billion pre-tax NPV at a 7% discount rate.*

*The valuation of the 45-year Reference Case for Northern Dynasty's 50% interest in the Pebble Project yields an 18.0% pre-tax and 15.4% post-tax IRR, a 4.7 year pre-tax and 5.3 year post-tax payback of initial capital investment and a \$3.6 billion pre-tax and 2.4 billion post-tax NPV at a 7% discount rate at long-term metal prices. At current prevailing metal prices, Northern Dynasty's 50% interest in the Pebble Project yields an 30.2% pre-tax and 25.1% post-tax IRR, a 2.6 year pre-tax and 3.1 year post-tax payback of initial capital investment and an \$8.3 billion pre-tax and \$5.6 billion post-tax NPV at a 7% discount rate.*

The 78-year Resource Case is based on a continuation of mining methods, costs and assumptions that inform the 25-year IDC Case and the 45-year Reference Case. By processing some 55% of the Pebble mineral resource over eight decades, it is intended to demonstrate the longer-term economic value of the Pebble Project. The 78-year Resource Case will process a total of some 6.5 billion tons of ore, primarily in Measured and Indicated categories from both the western and eastern portions of the Pebble deposit. Inferred resources comprise 33% of the total ore mined.

### **1.1.3 PROJECT PLANNING ALTERNATIVES**

As noted, the development cases presented in this Preliminary Assessment are based upon recent engineering and project design work conducted by the Pebble Partnership and Northern Dynasty. The Pebble Partnership continues to advance project planning initiatives as it works toward the completion of a Prefeasibility Study for the Pebble Project, including efforts to engage project stakeholders in the planning process. As such, the project description that the Pebble Partnership ultimately elects to submit for permitting under NEPA could differ from the development cases presented in this document.

While it's certain that near-surface mineral resources within the western portion of the Pebble deposit will be most efficiently developed through open pit methods, underground mining (in particular, block caving) remains an economically viable option at long-term metal prices for developing the deeper and higher-grade resources in the eastern portion. Each of the three development cases described in this Preliminary Assessment employ open pit mining methodologies only. However, it is expected that additional underground investigations will be undertaken during the initial 25 years of production.

The potential remains for underground block caving to emerge as the preferred mining method for subsequent phases of development at Pebble. While the economic evaluation of all three development cases presented in this Preliminary Assessment is based on open pit mining only, a detailed description of potential underground mine design, operations, production and costs is also provided.

As noted, phases of development beyond 25 years will require separate permitting and development decisions to be made in the future, based on prevailing conditions at the time and the accumulated experience gained from developing and operating the initial phase of the Pebble Project. Given its size, structure and polymetallic nature, the Pebble deposit presents a great deal of flexibility in near-term and long-term development options.

#### 1.1.4 MINERAL RESOURCE ESTIMATES

When Northern Dynasty acquired its initial interest in the Pebble Project in 2001, known mineral resources totalled some 1 billion tons in the near-surface western portion of the deposit. By 2005, Northern Dynasty had defined a 4.58 billion ton (4.16 billion tonne) deposit that came to be known as 'Pebble West' or the Pebble West zone.

Subsequent exploration work determined that mineralization at Pebble extends eastward and deeper into a higher-grade zone that came to be known as 'Pebble East' or the Pebble East zone. Between 2004 and 2009, exploration activity undertaken by Northern Dynasty and subsequently by the Pebble Partnership increased the overall Pebble mineral resource to nearly 11.9 billion tons (10.8 billion tonnes) – comprising 6.54 billion tons (5.94 billion tonnes) of Measured and Indicated resources and 5.33 billion tons (4.84 billion tonnes) of Inferred resources.

The Pebble deposit contains an estimated 55 billion lb copper, 67 million oz gold and 3.3 billion lb molybdenum in Measured and Indicated categories, and 25 billion lb copper, 40 million oz gold and 2.3 billion lb molybdenum in the Inferred category. This resource estimate has been prepared utilizing industry standard best-practice techniques refined over several years, and is informed by a database that has been subject to third-party scrutiny of QA/QC performance since 2004.

Tonnages stated at 0.3% copper equivalent (CuEQ) cut-off. See Table 1.6.1 for further details and CuEQ calculations.

#### 1.1.5 MINE PLANNING

The Pebble Project will be a large industrial facility located within a vast region of Alaska notable for its undeveloped wilderness, isolated and sparsely populated communities, Alaska Native culture and traditional ways of life, significant salmon fisheries, and other fish and wildlife populations.

Since 2004, Northern Dynasty and subsequently the Pebble Partnership have undertaken a comprehensive stakeholder outreach program to document the priorities and concerns of local communities and area residents, and prepare them to participate in the process by which the Pebble Project will be designed, permitted, built and operated. Concurrently, extensive baseline studies have been undertaken to characterize the physical, chemical, biological and social environment of the project area. These studies have resulted in a superior database, which – in characterizing the climate, surface and groundwater hydrology, wetlands, terrestrial wildlife habitat, fish and aquatic habitat, and marine habitat – has guided all aspects of project planning.

Since 2004, a broad range of development options for the Pebble Project have been evaluated to accommodate the growing mineral resource, its location and the environmental and cultural sensitivities of the region. Project planning elements include:

- a mining plan;
- process plant;
- management of water and waste;
- transportation corridors;

- deep-water port;
- infrastructure; and
- power supply.

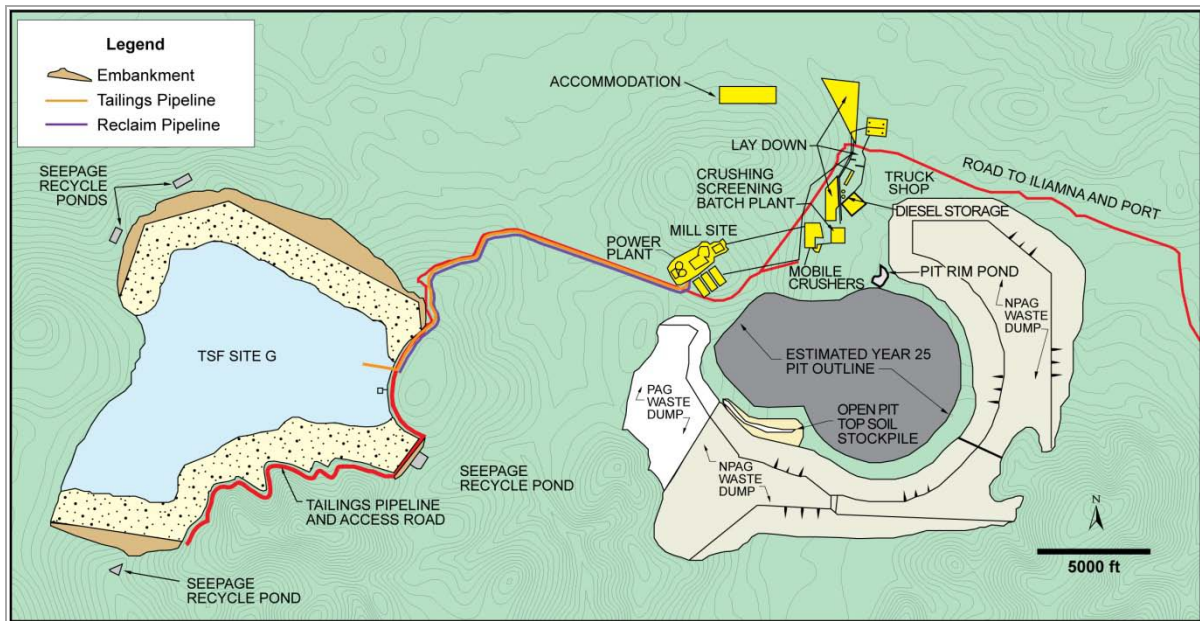
It should be noted that the Pebble Partnership continues to advance engineering and project design initiatives toward the completion of a Prefeasibility Study for the Pebble Project. This effort will be informed by input received from project stakeholders through public consultation exercises undertaken in Alaska prior to the completion of a Prefeasibility Study and the submission of permit applications.

### 1.1.6 MINE DEVELOPMENT

The current status of mine planning for the Pebble Project, as reflected in this Preliminary Assessment, contemplates:

- open pit mining utilizing conventional drill, blast and truck-haul methods, with an initial life of 25 years and potential for mine extensions to 78 years and beyond;
- a process plant with a nominal mill throughput of 200,000 tons per day, utilizing conventional crush-grind-float technology and equipment, and secondary gold recovery;
- various mine-site facilities and installations including: tailing storage; rock storage; a natural gas-fired power plant; shop, office and camp buildings; and
- pipeline and transportation infrastructure.

**Figure 1.1.3 General Mine and Tailings Storage Facility Layout**



The 25-year IDC Case will allow for detailed engineering studies to determine if remaining high-grade ore in the eastern portion of the deposit should be developed through open pit mining or underground block caving methods.

Copper-gold concentrate produced on-site at Pebble will be transported via a slurry pipeline to a new deep-water port on Cook Inlet. There it will be de-watered and bulk shipped to offshore smelters. Other products of the process plant are: gold doré, which will be flown to market from Iliamna; and molybdenum concentrate, which will be bagged and trucked to the port for shipment.

Process tailings will be stored behind purpose-built embankments during mining, and thereafter in the pit. A Pebble mine life extension beyond 25 years will require a secondary tailings storage facility (TSF) to be developed. Engineering to a preliminary level for alternate TSF sites with sufficient capacity to receive mine tailings after 25 years has been completed; topographical and land status conditions in the project area present a number of nearby siting opportunities. Phases of development beyond 25 years will require separate permitting and development decisions to be made in the future, based on prevailing conditions at the time and the accumulated experience gained from developing and operating the initial phase of the Pebble Project.

Results of water balance studies indicate there will be a site-wide water surplus at the Pebble Project over the life of the mine. Surplus water will be treated to meet prevailing regulatory standards for water quality and the protection of aquatic life, and released to optimize downstream flow conditions for fish and aquatic habitat.

### 1.1.7 INFRASTRUCTURE

An 86-mile transportation corridor will be developed to link the Pebble mine to a new deep-water port on Cook Inlet, 66 miles to the east. About 80% of the transportation corridor is on private land owned by various Alaska Native Village Corporations, with which the Pebble Partnership has existing commercial partnerships. The balance of the transportation corridor is on land owned by the State of Alaska.

The transportation corridor will include a two-lane, all-weather permanent access road. The primary purpose of the road will be to transport freight by conventional highway tractors and trailers, although critical elements of the design will be dictated by specific oversize and overweight loads associated with project construction.

The transportation corridor will also include four buried, parallel pipelines, including:

- a copper-gold concentrate slurry pipeline from the mine site to the port;
- a return water pipeline from the port site to the mine;
- a natural gas pipeline from the port site to the mine to fuel a natural gas-fired generating plant at the mine site; and
- a diesel fuel pipeline from the port site to the mine.

**Figure 1.1.4 Iliamna Airport**



**Figure 1.1.5 Transportation Corridor and Port Site 1 Location**



A permanent deep-water port (Port Site 1) will be developed at the entrance to Iniskin Bay on Cook Inlet to serve as a product load-out facility, and to facilitate in-bound fuel, equipment and supply shipments. On an annual basis, this port facility is designed to accommodate shipping of 1.1 million

tons of concentrate in Handymax vessels of approximately 50,000 tons, as well as diesel fuel and container barges of equipment and supplies.

Energy requirements for the Pebble Project will be met via a 378 MW combined-cycle natural gas-fired turbine plant at the mine site, as well as an 8 MW natural gas-fired generation plant at the port site. Meteorological data collected at Pebble has identified the potential for wind energy to support natural gas-fired generation, and will be further explored in subsequent stages of project planning.

Current project planning assumes that the nearby Cook Inlet gasfield does not currently have adequate natural gas supplies to meet project needs. Natural gas is planned to be sourced from other regions of Alaska or imported as liquefied natural gas (LNG), transported by pipeline from the Kenai Peninsula across Cook Inlet via a sea-bottom line to Port Site 1 and along the transportation corridor to the mine site.

Diesel fuel will be transported via pipeline from the port fuel storage facility to the mine site. Besides fuelling mobile mining equipment and other rolling stock, emergency electrical generators will also operate on diesel fuel.

#### **1.1.8 PROJECT WORKFORCE**

Construction of the Pebble Project is projected to take four years, with a peak labour force of 2,080. The operations workforce is projected to average 1,120 over the initial 25-year life of the mine, with longer-term labour requirements to be determined by the mine development alternatives selected. Both construction and operations workforces will be accommodated in project camps at the mine site and the port site, and will work on a rotational basis. The Pebble Partnership has stated its intention to maximize local and Alaskan hire at the Pebble Project, and is developing a workforce development plan to accomplish this goal.

#### **1.1.9 PRODUCTION PROFILES**

The 25-year IDC Case will process 1.99 billion tons of ore with a strip ratio of 1.5: 1 and average grades of 0.38% Cu, 0.012 oz Au/ton, 182 ppm Mo. Metallurgical recoveries average 86.6% for copper, 71.5% for gold and 84.8% for molybdenum.

Over the life-of-mine, the 25-year IDC Case will produce some 12.9 Blb of copper, 16.4 Moz of gold and 616 Mlb of molybdenum, as well as 67 Moz of silver, 502,000 kg of rhenium and 385,000 oz of palladium.

The 45-year Reference Case will process 3.8 billion tons of ore, with a strip ratio of 2.1:1 and average grades of 0.46% Cu, 0.011 oz Au/ton and 214 ppm Mo. Metallurgical recoveries average 87.9% for copper, 71.3% for gold and 87.9% for molybdenum.

Over the life-of-mine, the 45-year Reference Case will produce 30.5 Blb of copper, 30.3 Moz of gold and 1.4 Blb of molybdenum, as well as 140 Moz of silver, 1.2 Mkg of rhenium and 907,000 oz of palladium.



The 78-year Resource Case will process 6.5 billion tons of ore, with a strip ratio of 2.6:1 and average grades of 0.46% Cu, 0.011 oz Au/ton and 243 ppm Mo. Metallurgical recoveries average 88.4% for copper, 71.2% for gold and 89.4% for molybdenum.

Over the life-of-mine, the 78-year Resource Case will produce 53.4 Blb of copper, 50.1 Moz of gold and 2.8 Blb of molybdenum, as well as 242 Moz of silver, 2.3 Mkg of rhenium and 1.59 Moz of palladium.

**Table 1.1.1 Pebble Project – Summary of Production Results – All Cases**

Item	Unit	IDC Case	Reference Case	Resource Case
Mine Life	years	25	45	78
Mining Method		Open Pit	Open Pit	Open Pit
Production Rate	M ton/year	80	84	84
Strip Ratio	waste : ore	1.5	2.1	2.6
Total Processed	M ton	1,990	3,767	6,528
% of M+I+I Resource	%	17	32	55
Copper Eq. Grade	%	0.72	0.83	0.84
Copper Grade	%	0.38	0.46	0.46
Gold Grade	oz/ton	0.012	0.011	0.011
Molybdenum Grade	ppm	182	214	243
Copper Recovery	%	86.6	87.9	88.4
Gold Recovery	%	71.5	71.3	71.2
Molybdenum Recovery	%	84.8	87.9	89.4
Copper Equivalent Recovered	Mlb	24,483	54,129	96,357
Copper Recovered	Mlb	12,944	30,494	53,437
Gold Recovered	k oz	16,391	30,307	50,133
Molybdenum Recovered	M lb	616	1,420	2,835
Peak Annual Copper Recovered	M lb	822	1,157	1,096
Peak Annual Gold Recovered	k oz	1,038	1,127	1,088
Peak Annual Molybdenum Recovered	M lb	43	56	62
Avg Annual Copper Recovered	M lb	518	678	685
Avg Annual Gold Recovered	k oz	656	673	643
Avg Annual Molybdenum Recovered	M lb	25	32	36
26% Cu Concentrate Produced	k dmt	22,582	53,200	93,225
52% Mo Concentrate Produced	k dmt	537	1,239	2,473

**Note:** By prescribed definition, “Mineral Resources” do not have demonstrated economic viability. Measured and Indicated Resources are that part of a mineral resource for which quantity and grade can be estimated with a level of confidence sufficient to allow the application of technical and economic parameters to support mine planning and evaluation of the economic viability of the project. Inferred Mineral Resources are that part of a mineral resource for which quantity and grade can be estimated on the basis of geological evidence and limited sampling and reasonably assumed, but not verified, geological and grade continuity. Inferred Mineral Resources are considered too speculative to allow the application of technical and economic parameters to support mine planning and evaluation of the economic viability of the project. The mineral resources fall within a volume or shell defined by long-term metal price estimates of US\$2.50/lb for copper, US\$900/oz for gold and US\$25/lb for molybdenum.

### 1.1.10 FINANCIAL RESULTS

Economic valuations of the three development cases presented in this Preliminary Assessment are expressed in US dollars in real terms. The valuation date on which the NPV, IRR and other financial results are based is at the commencement of project construction.

Long-term and current prevailing metal prices applied to the financial model for each of the development cases are outlined in Table 1.1.2.

**Table 1.1.2 Pebble Project – Metal Price Assumptions**

Metal Type	Unit	Long-term Metal Prices	Current Prevailing Metal Prices
Copper	\$/lb	2.50	4.00
Gold	\$/oz	1,050	1,350
Molybdenum	\$/lb	13.50	15.00
Silver	\$/oz	15.00	28.00
Rhenium	\$/kg	3,000	3,000
Palladium	\$/oz	490	490

Annual cash flows are calculated and subsequently discounted at a rate of 7%. Market convention generally uses a discount rate of 8% for copper and other base metal projects and 5% for gold and other precious metal projects. Given the large contribution of gold to total revenue at the Pebble Project, a 7% blended discount rate has been selected by Wardrop and is considered appropriate for discounting the Pebble Project cash flows for discounted cash flow analysis purposes.

The discounted cash flow analysis for each of the three development cases provided below considers:

- annual recovered metal production statistics, incorporating tonnage milled, head grades and recoveries;
- long-term metal prices for copper, gold, molybdenum, silver, rhenium and palladium as above, adjusted to realize price levels by applying smelting, refining and concentrate transport charges;
- fixed and variable operating costs; and
- initial and sustaining capital costs.

Based on these inputs and considerations, the economic valuation for each of the three Pebble Project development cases at long-term metal prices are summarized below:

The 25-Year IDC Case achieves a pre-tax NPV of \$3.8 billion, a pre-tax IRR of 13.4% and a payback period of 6.5 years.

The 45-Year Reference Case achieves a pre-tax NPV of \$6.1 billion, a pre-tax IRR of 14.2% and a payback period of 6.2 years.

The 78-Year Resource Case achieves a pre-tax NPV of \$6.8 billion, a pre-tax IRR of 14.5% and a payback period of 6.1 years.

The Pebble Project Financial Summary is outlined in Table 1.1.3. Financial results are also shown at current prevailing metal prices.

**Table 1.1.3 Pebble Project – Summary Financial Results – All Cases**

Item	Unit	IDC Case	Reference Case	Resource Case
Mine Life	years	25	45	78
Mining Method		Open Pit	Open Pit	Open Pit
Initial Capital	\$ M	4,695	4,695	4,695
LOM Sustaining Capital	\$ M	3,204	6,140	11,727
LOM NSR	\$ M	54,637	120,197	213,970
NSR Per Ton	\$/ton	27.45	31.91	32.78
LOM Operating Cost	\$ M	22,208	43,489	96,063
Operating Cost Per Ton	\$/ton	11.16	11.55	14.72
C1 Copper Cost	\$/lb	-0.10	-0.11	0.21
LOM Pre-Tax Net Cash Flow	\$ M	20,123	55,278	87,329
<b>Long-term Metal Prices</b>				
Pre-Tax NPV at 7%	\$ M	3,837	6,129	6,812
Pre-Tax IRR	%	13.4%	14.2%	14.5%
Pre-Tax Payback	years	6.5	6.2	6.1
<b>Current Prevailing Metal Prices</b>				
Pre-Tax NPV at 7%	\$ M	11,410	15,709	16,864
Pre-Tax IRR	%	22.6%	23.2%	23.3%
Pre-Tax Payback	years	3.2	3.2	3.2

**Notes:**

Long-term metal prices used for the financial analysis were \$2.50/lb for copper, \$1050/oz for gold, \$13.50/lb for molybdenum and \$15.00/oz for silver. Current prevailing metal prices used for the financial analysis were \$4.00/lb for copper, \$1350/oz for gold, \$15.00/lb for molybdenum and \$28.00/oz for silver.

Pre-tax results are before income taxes but after NPI royalty and local production taxes.

C1 Copper Cost is Copper Cash Cost (Operating Costs plus Realization Costs) after by-product credits.

By prescribed definition, "Mineral Resources" do not have demonstrated economic viability. Measured and Indicated Resources are that part of a mineral resource for which quantity and grade can be estimated with a level of confidence sufficient to allow the application of technical and economic parameters to support mine planning and evaluation of the economic viability of the project. Inferred Mineral Resources are that part of a mineral resource for which quantity and grade can be estimated on the basis of geological evidence and limited sampling and reasonably assumed, but not verified, geological and grade continuity. Inferred Mineral Resources are considered to be too speculative to allow the application of technical and economic parameters to support mine planning and evaluation of the economic viability of the project. The mineral resources fall within a volume or shell defined by long-term metal price estimates of US\$2.50/lb for copper, US\$900/oz for gold and US\$25/lb for molybdenum.

**NORTHERN DYNASTY FINANCIAL RESULTS**

Under the terms of the Pebble Limited Partnership Agreement, Anglo American is required to elect to continue its staged investment of \$1.425 to \$1.5 billion in staged investments in order to retain its 50% interest in the Pebble Project. If a feasibility study for the Pebble Project is completed after 2011, Anglo American's overall funding requirement increases from \$1.425 billion to \$1.5 billion. A significant proportion of this earn-in contribution is expected to be applied to initial capital costs to construct the

mine, thereby reducing Northern Dynasty’s capital requirement to maintain its 50% interest in the project.

In order to calculate an NPV and IRR estimate for Northern Dynasty’s 50% interest in the Pebble Project under this earn-in scenario, it is necessary to adjust Northern Dynasty’s share of initial capital costs. For the purpose of this calculation, it is assumed that \$1 billion of Anglo American’s current funding commitment will be applied to the Pebble Project’s capital cost for construction.

Based on the same financial inputs and considerations described in the ‘Financial Results’ section above, as well as Northern Dynasty’s reduced capital requirements, the economic valuation of Northern Dynasty’s interest in each of the three development cases are summarized below:

The 25-Year IDC Case achieves a pre-tax NPV of \$2.4 billion, a pre-tax IRR of 17.3% and a payback period of 4.9 years for Northern Dynasty’s interest.

The 45-Year Reference Case achieves a pre-tax NPV of \$3.6 billion, a pre-tax IRR of 18.0% and a payback period of 4.7 years for Northern Dynasty’s interest.

The 78-Year Resource Case achieves a pre-tax NPV of \$3.9 billion, a pre-tax IRR of 18.4% and a payback period of 4.6 years for Northern Dynasty’s interest.

The Northern Dynasty financial results for the Pebble Project are outlined in Table 1.1.4

**Table 1.1.4 Northern Dynasty – Summary Financial Results – All Cases**

Item	Unit	IDC Case	Reference Case	Resource Case
Mine Life	years	25	45	78
Mining Method		Open Pit	Open Pit	Open Pit
<b>Long-term Metal Prices</b>				
Pre-Tax NPV at 7%	\$ M	2,403	3,550	3,891
Pre-Tax IRR	%	17.3%	18.0%	18.4%
Pre-Tax Payback	years	4.9	4.7	4.6
<b>Current Prevailing Metal Prices</b>				
Pre-Tax NPV at 7%	\$ M	6,190	8,339	8,917
Pre-Tax IRR	%	29.5%	30.2%	30.4%
Pre-Tax Payback	years	2.7	2.6	2.6

**Notes:**

Long-term metal prices used for the financial analysis were \$2.50/lb for copper, \$1,050/oz for gold, \$13.50/lb for molybdenum, and \$15.00/oz for silver. Current prevailing metal prices used for the financial analysis were \$4.00/lb for copper, \$1,350/oz for gold, \$15.00/lb for molybdenum, and \$28.00/oz for silver.

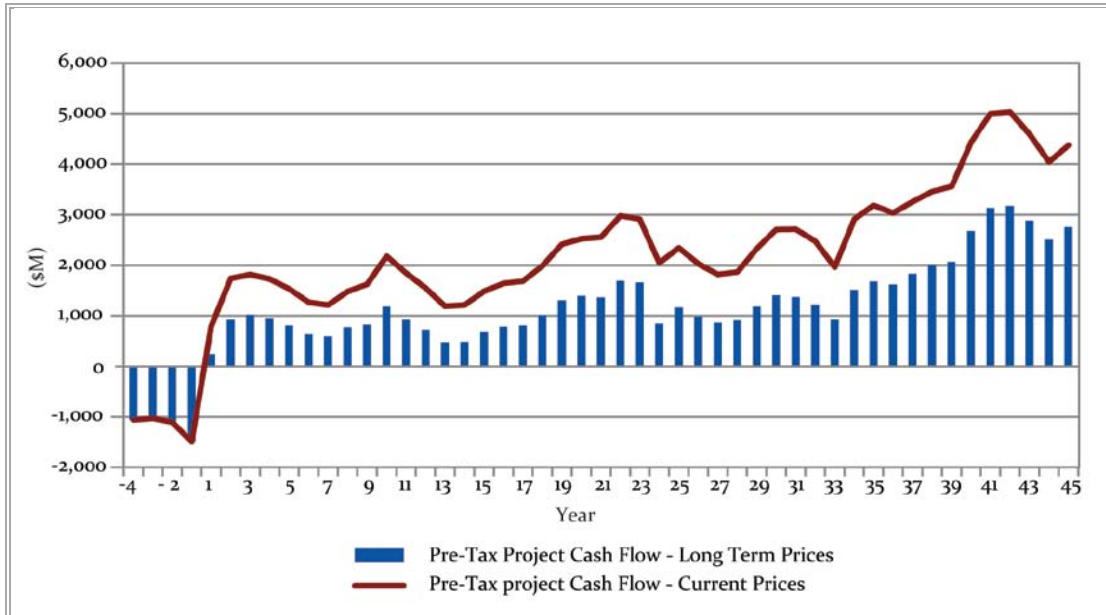
Pre-tax results are before income taxes but after NPI royalty and local production taxes.

By prescribed definition, “Mineral Resources” do not have demonstrated economic viability. Measured and Indicated Resources are that part of a mineral resource for which quantity and grade can be estimated with a level of confidence sufficient to allow the application of technical and economic parameters to support mine planning and evaluation of the economic viability of the project. Inferred Mineral Resources are that part of a mineral resource for which quantity and grade can be estimated on the basis of geological evidence and limited sampling and reasonably assumed, but not verified, geological and grade continuity. Inferred Mineral Resources are considered to be too speculative to allow the application of technical and economic parameters to support mine planning and evaluation of the economic viability of the project. The mineral resources fall within a volume or shell defined by long-term metal price estimates of US\$2.50/lb for copper, US\$900/oz for gold and US\$25/lb for molybdenum.

PEBBLE PROJECT FINANCIAL RESULTS

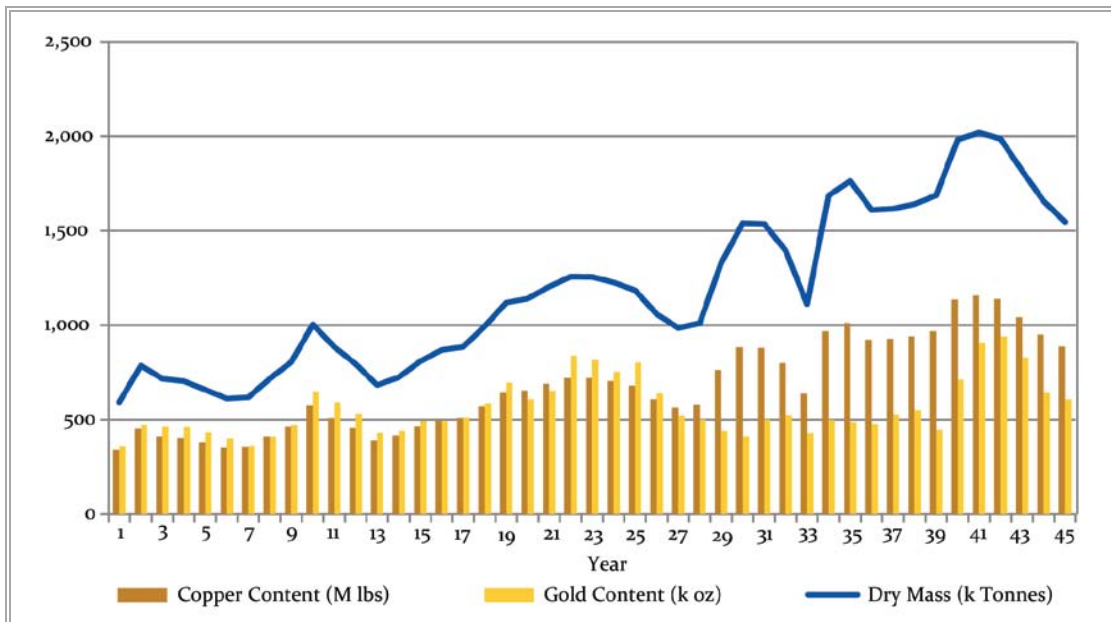
Pre-tax cash flows for the Pebble Project for the 45-year Reference Case are illustrated in Figure 1.1.6 for both long-term and current prevailing metal prices.

**Figure 1.1.6 Pebble Project – 45-year Reference Case Pre-Tax Cash Flows**



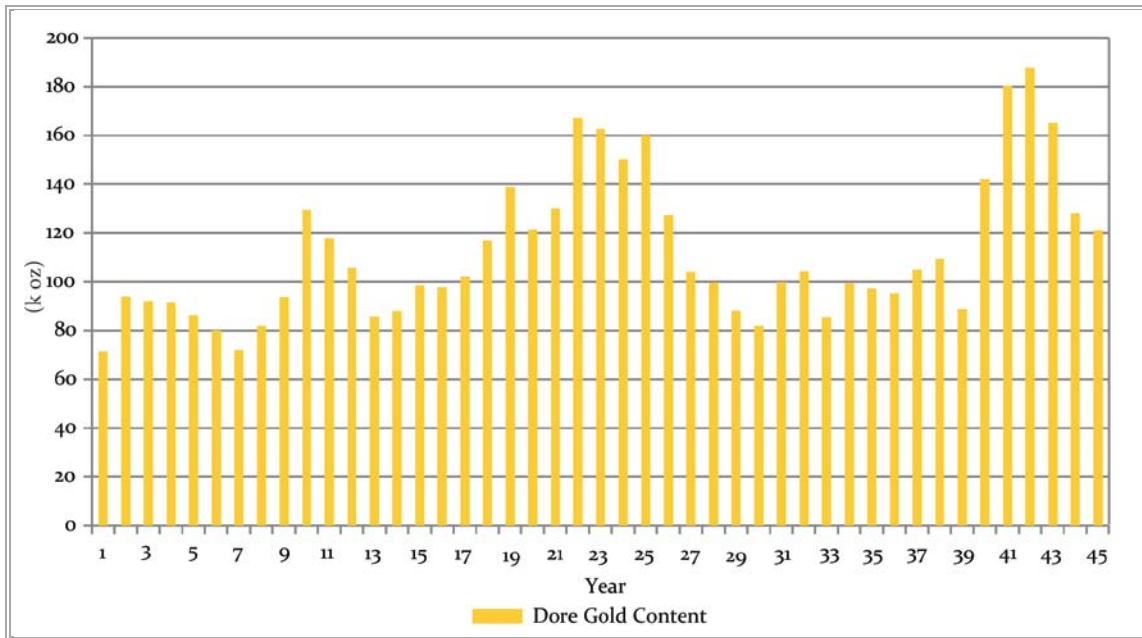
Production of 26% copper-gold concentrate, along with copper and gold metal, for the 45-year Reference Case is shown in Figure 1.1.7.

**Figure 1.1.7 Pebble Project – 45-year Reference Case Copper-Gold Concentrate Production**



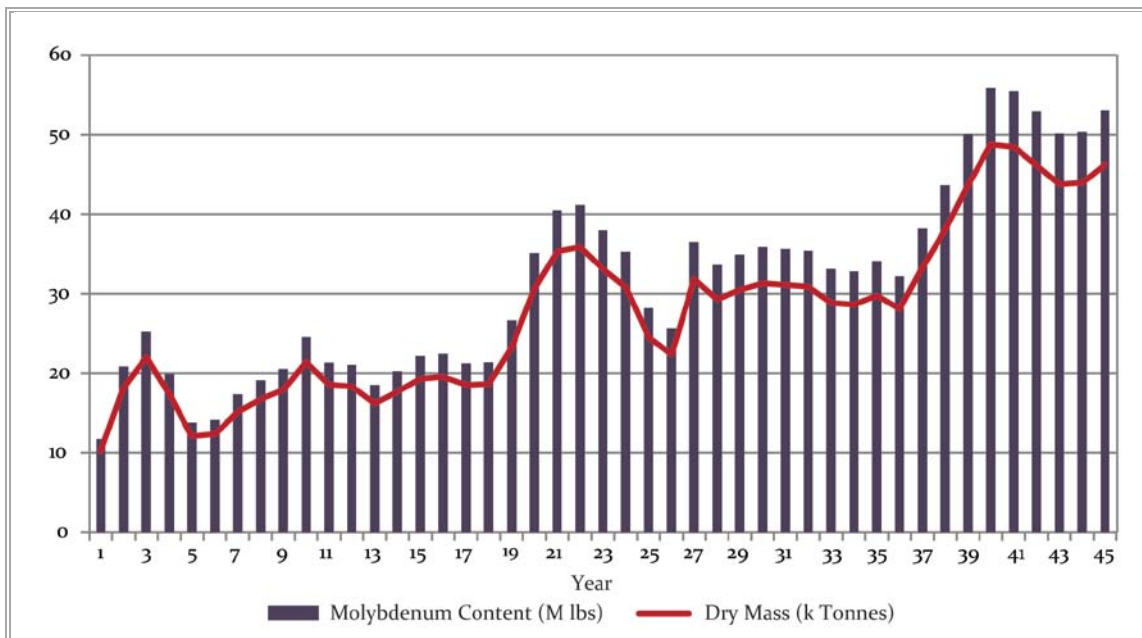
Gold in doré production from the gold plant is shown in Figure 1.1.8.

**Figure 1.1.8 Pebble Project – 45-year Reference Case Gold in Doré Production**



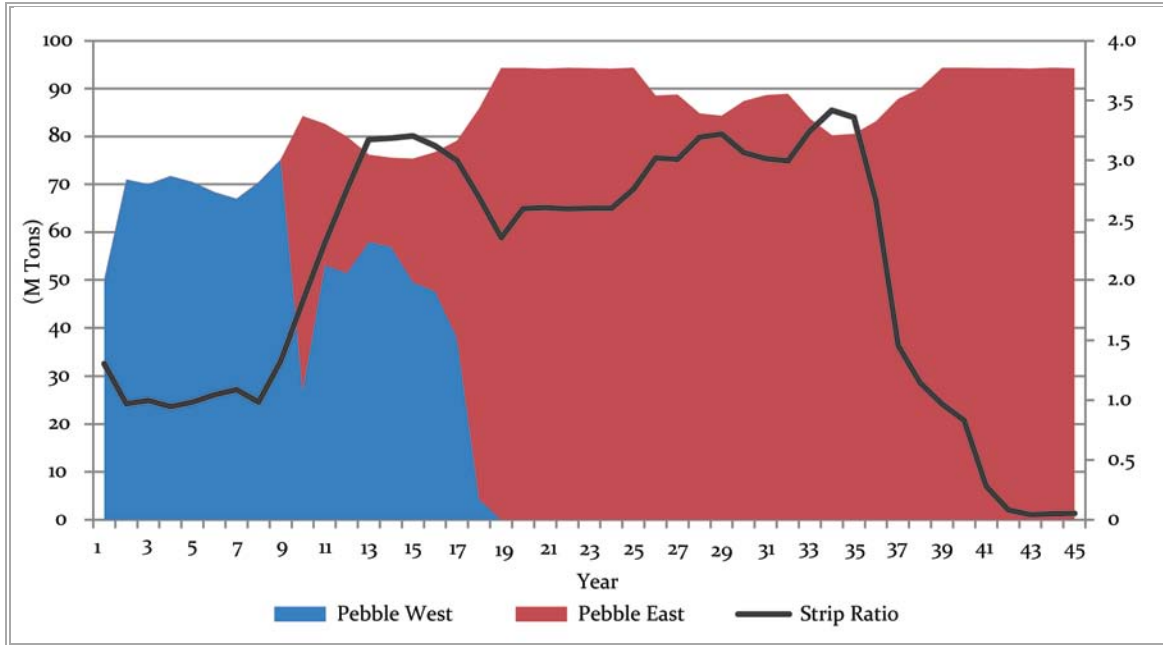
The production of 52% molybdenum concentrate and molybdenum metal for the 45-year Reference Case are shown in Figure 1.1.9.

**Figure 1.1.9 Pebble Project – 45-year Reference Case Molybdenum Concentrate Production**



Annual production tonnages and strip ratio for the 45-year Reference Case are illustrated in Figure 1.1.10.

**Figure 1.1.10 Pebble Project – 45-year Reference Case Tons Milled and Strip Ratio**



## 1.2 LOCATION AND ACCESS

The Pebble deposit is located in southwest Alaska at latitude 59°53'45" N and longitude 155°17'44" W, as shown in Figure 1.2.1. The project area is characterized by tundra, gently rolling hills (Figure 1.2.2) and the absence of permafrost. Several periods of glaciation have rounded the topography and filled the valley bottoms with glacial debris, moraines and lake-bottom sediments. The surface elevation over the deposit ranges from 800 to 1,200 ft amsl, while the surrounding mountains reach 3,000 to 4,000 ft amsl.

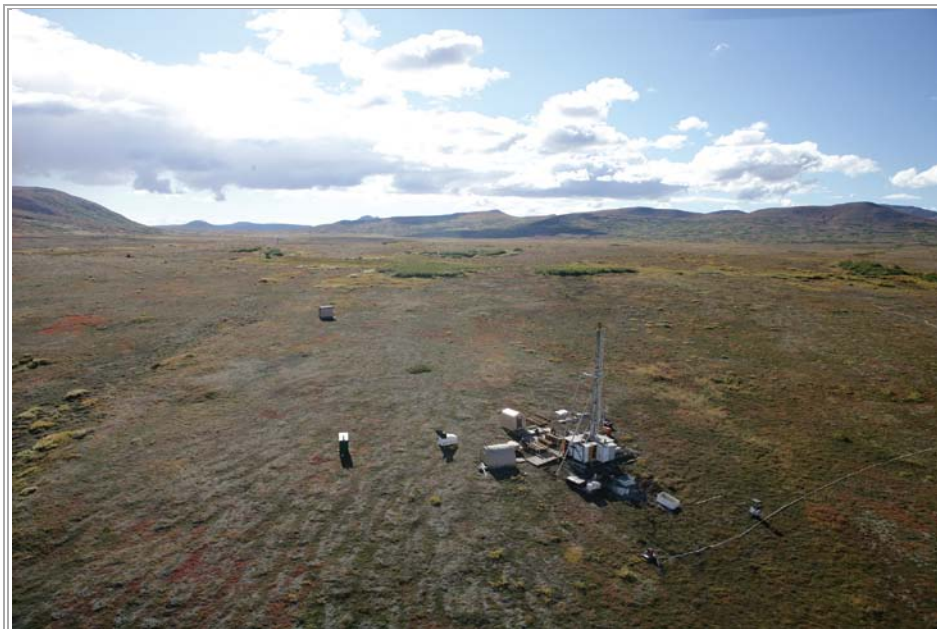
Year-round access to the Pebble Project is currently achieved via air travel from Anchorage to the village of Iliamna, which is served by two 5,000-ft airstrips. The deposit area lies 17 miles to the northwest of Iliamna and is accessed via helicopter, although local transportation infrastructure includes paved roads and barging on Lake Iliamna.

The planned access route from the mine site to Cook Inlet parallels the north shore of Lake Iliamna and follows similar terrain for approximately 50 to 60 road miles until reaching steeper hillsides near the village of Pedro Bay. After crossing gentler terrain around the northeast end of Iliamna Lake, the transportation route crosses the Chignit Mountains of the Aleutian Range to Cook Inlet.

**Figure 1.2.1 Pebble Project Location – Southwest Alaska**



**Figure 1.2.2 Drill Rig over the Pebble Deposit**





The climate in the deposit area is transitional. It is more continental in winter because of frozen water bodies and sea ice in Bristol Bay and more maritime in summer due to the influence of the open water of Iliamna Lake and, to a lesser extent, the Bering Sea and Cook Inlet. Mean monthly temperatures range from about 55°F (13°C) in July/August to 2°F (-17°C) in March.

The Pebble Project area is isolated and sparsely populated. It lies almost completely within the Lake and Peninsula Borough, which has a population of about 1,500 persons in 17 communities. The nearest communities are located 17 – 19 miles to the southeast (Iliamna and Newhalen) and northeast (Nondalton) of the Pebble deposit. Pedro Bay lies some 40 miles east along the road route to the port. None of the local villages has more than 250 full-time residents.

### 1.3 TENURE, SURFACE RIGHTS AND AGREEMENTS

---

Northern Dynasty holds indirect interests in 592 mi<sup>2</sup> (378,600 acres) of mineral claims in southwest Alaska (see Figure 1.3.1). These include:

- 2,043 claims covering 330 mi<sup>2</sup> (210,840 acres) held by the Pebble Partnership through subsidiaries Pebble East Claims Corporation and the Pebble West Claims Corporation (including the Pebble deposit);
- 95 claims covering 24 mi<sup>2</sup> (15,200 acres) held by a wholly-owned subsidiary of Northern Dynasty;
- 542 claims covering 136 mi<sup>2</sup> (86,720 acres) held by Full Metal Minerals (USA) Inc., which the Pebble Partnership may acquire; and
- 428 mineral claims covering 102.9 mi<sup>2</sup> (65,840 acres) held by Liberty Star Uranium and Metals Corp., in which Northern Dynasty has entered into an agreement to earn an interest.

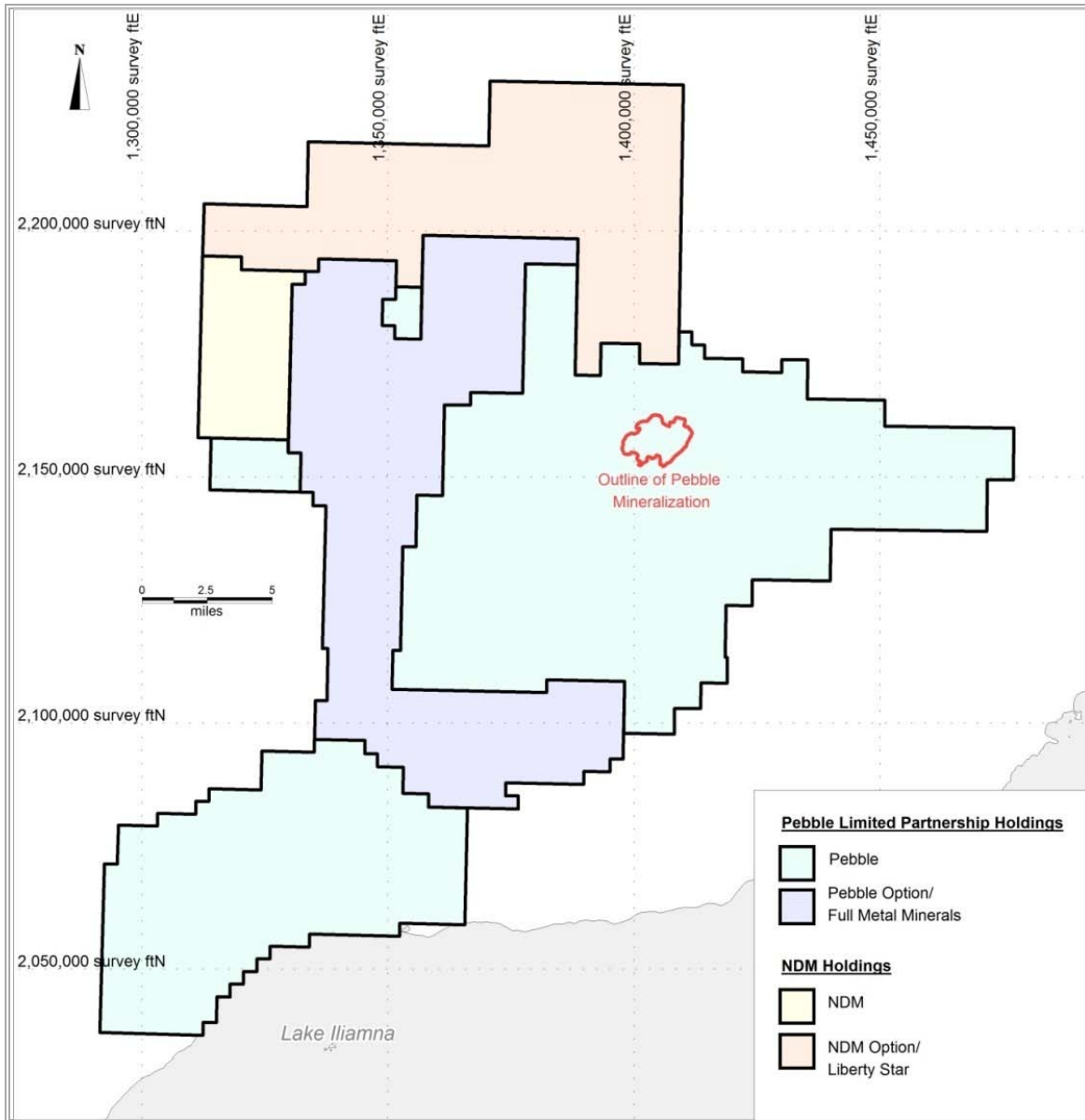
The Pebble Partnership is acquiring the right to earn a 60% interest in Full Metal's mineral claims by incurring exploration expenditures of at least \$3 million over three years, plus other considerations. The Pebble Partnership will also have the right to purchase certain claims outright.

Northern Dynasty has the right to earn a 60% interest in Liberty Star's mineral claims by incurring exploration expenditures of \$10 million over six years.

State of Alaska assessment requirements and rental fees for 2010 have been met for all noted mineral claims.

Neither Northern Dynasty nor the Pebble Partnership holds surface rights. Surface rights are acquired from the State of Alaska once areas required for mine development have been determined and permits awarded. None of the listed properties presents environmental liabilities.

Figure 1.3.1 Pebble Property Claim Map



## 1.4 GEOLOGY AND EXPLORATION

### 1.4.1 HISTORY

In the mid-1980s, Cominco began reconnaissance exploration in the Pebble region, leading to the discovery of both the Sill prospect and the Pebble discovery outcrop. Drilling on the Pebble deposit began in 1988 and continued through 1997 with a total of 117 holes completed totalling 62,930 ft. During this time, baseline environmental, engineering, and preliminary economic studies were initiated.

Since 2001 Northern Dynasty and subsequently the Pebble Partnership have staked additional claims, conducted further geochemical and geophysical surveys and completed 698,296 ft of drilling delineating the Pebble deposit, as well as 169,151 ft of drilling elsewhere on the property. This work has resulted in a significant expansion of the western portion of the Pebble deposit, and the discovery of a higher-grade zone to the east. Extensive engineering, baseline environmental studies and stakeholder engagement work has been ongoing during this time.

#### 1.4.2 GEOLOGY

Southwest Alaska is composed of an assemblage of northeast-trending tectonostratigraphic terranes that amalgamated southward in response to long-lived, northeast- to northwest-directed subduction, beginning in the Late Paleozoic (Goldfarb, 1997). The Pebble district is located within the Kahiltna Terrane, just northwest of its contact with the Peninsular Terrane to the southeast. This part of the Kahiltna is dominated by Late Jurassic to Early Cretaceous basinal turbidites, which were deposited in a narrow basin aligned with the subduction suture zone against the continental (Alaska) side of the Wrangellia volcanic arc terrane. The Wrangellia and Kahiltna terranes docked to Alaska in the Cretaceous Period.

The Pebble property comprises Jura-Cretaceous to Eocene igneous and sedimentary rocks (Figure 1.4.1). Jura-Cretaceous flysch and interbedded mafic to intermediate volcanic flows and tuffs were intruded at about 96 Ma by subalkalic diorite and granodiorite sills along with alkalic pyroxenite, monzodiorite, monzonite and syenomonzonite. Granodiorite of the Kaskanak batholith was emplaced at about 90 Ma, accompanied by smaller, coeval bodies of granodiorite which are related to at least some stages of porphyry copper-gold-molybdenum and other styles of intrusion-related mineralization in the eastern part of the district, including the Pebble deposit. The district was subjected to extensive erosion, and sedimentary and volcanic strata were deposited sometime between about 89 and 65 Ma. Eocene (~46 Ma) volcanic rocks overlie the older units. Low-lying parts of the district are covered by thin fluvio-glacial sediments.

The Pebble deposit is a calc-alkalic copper-gold-molybdenum porphyry deposit which formed in association with granodiorite intrusions emplaced at about 90 Ma. The deposit comprises the contiguous Pebble West and Pebble East zones. Mineralization is associated with several coalescing hydrothermal centres formed around small granodiorite stocks which intruded Jura-Cretaceous flysch, diorite and granodiorite sills, and alkalic intrusions and associated breccias. Pebble West extends to surface. Mineralization in the Pebble East zone occurs within a granodiorite stock, and in surrounding flysch cut by granodiorite sills, and is overlain by east-thickening, post-mineralization volcanic and sedimentary strata. The mineralization at Pebble East is deeper and higher grade than that in Pebble West (Figure 1.4.2).

Figure 1.4.1 District Geology of the Pebble Project

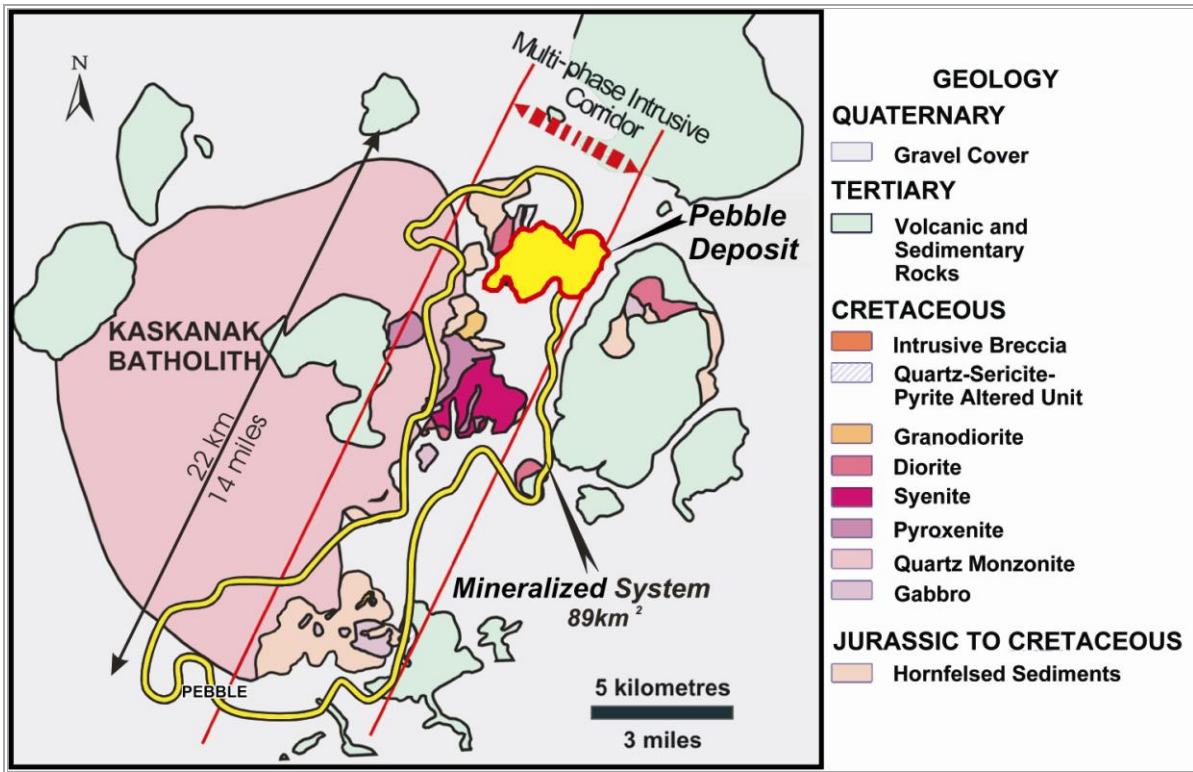
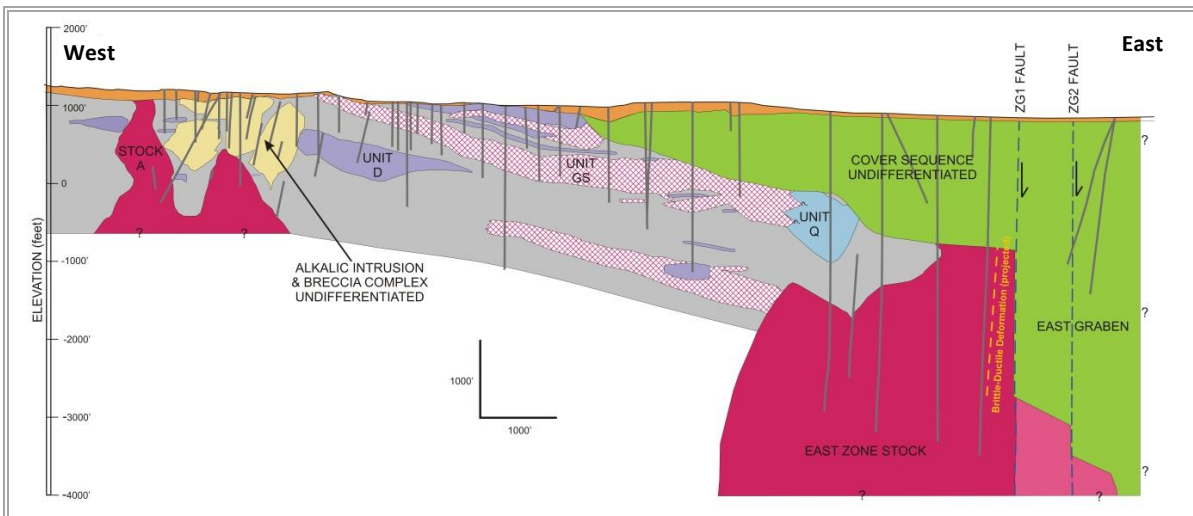


Figure 1.4.2 Pebble Deposit East-West Cross Section



### 1.4.3 MINERALIZATION

Mineralization in the Pebble East and Pebble West zones precipitated during formation of early K-silicate alteration and associated quartz-sulphide veins. Additional gold-copper mineralization precipitated in the eastern part of Pebble East during a structurally-controlled overprint by advanced argillic alteration. Mineralization is dominated by hypogene pyrite, chalcopyrite and molybdenite. Bornite is also an important component in some parts of the Pebble East zone. The Pebble West zone has a thin, volumetrically subordinate zone of supergene mineralization and a very minor zone of oxide mineralization. The Pebble East zone contains only hypogene mineralization.

Copper-gold-molybdenum mineralization, as currently known, extends over an east-west elongated area of 2.8 x 1.9 mi (4.9 x 3.3 km), and to a depth of 2,000 ft (610 m) in the Pebble West zone and to at least 5,000 ft (1,525 m) in the Pebble East zone (Figure 1.4.3 and Figure 1.4.4). Mineralization in the Pebble East zone remains open to the east, north and south. A much larger zone of strong alteration and low-grade mineralization extends north, south and west of the known Pebble deposit.

Mineralization in the Pebble West zone is mostly hypogene but also includes minor oxide (leached) and supergene zones. The leached zone forms a cap at the top of the Pebble West zone and is generally less than 100 ft thick. In general, most copper has been leached, whereas gold remains essentially intact. Locally, very minor malachite, chrysocolla, native copper and/or other secondary copper minerals are present. This zone immediately overlies a supergene zone, which can be several hundred feet thick and contains variable amounts of chalcocite, covellite and relict hypogene chalcopyrite. Mineralization in the Pebble East zone is entirely hypogene, without evidence of leaching or paleo-supergene effects below the unconformity with the cover sequence. There is no supergene mineralization in Pebble East below the Tertiary unconformity and non-mineralized overlying rocks.

The vast majority of mineralization in both the Pebble West and Pebble East zones is hypogene. There are two distinct assemblages of hypogene mineralization – chalcopyrite-dominated hypogene and replacement bornite hypogene. The chalcopyrite-dominated hypogene is the most common hypogene mineral assemblage and occurs in all but certain parts of the Pebble East zone, as described below. It contains chalcopyrite as the only significant copper mineral. The second type of hypogene mineralization occurs in the upper part of the south half of the Pebble East zone. In this portion of the deposit, the chalcopyrite-dominated hypogene mineralization which precipitated during early K-silicate alteration has been partially replaced by a variable assemblage of hypogene bornite, digenite, covellite, tennantite-tetrahedrite and/or minor enargite related to advanced argillic alteration.

Figure 1.4.3 Plan View of Relative Mineralization Concentration of the Pebble Deposit (Grade Calculated as CuEQ)

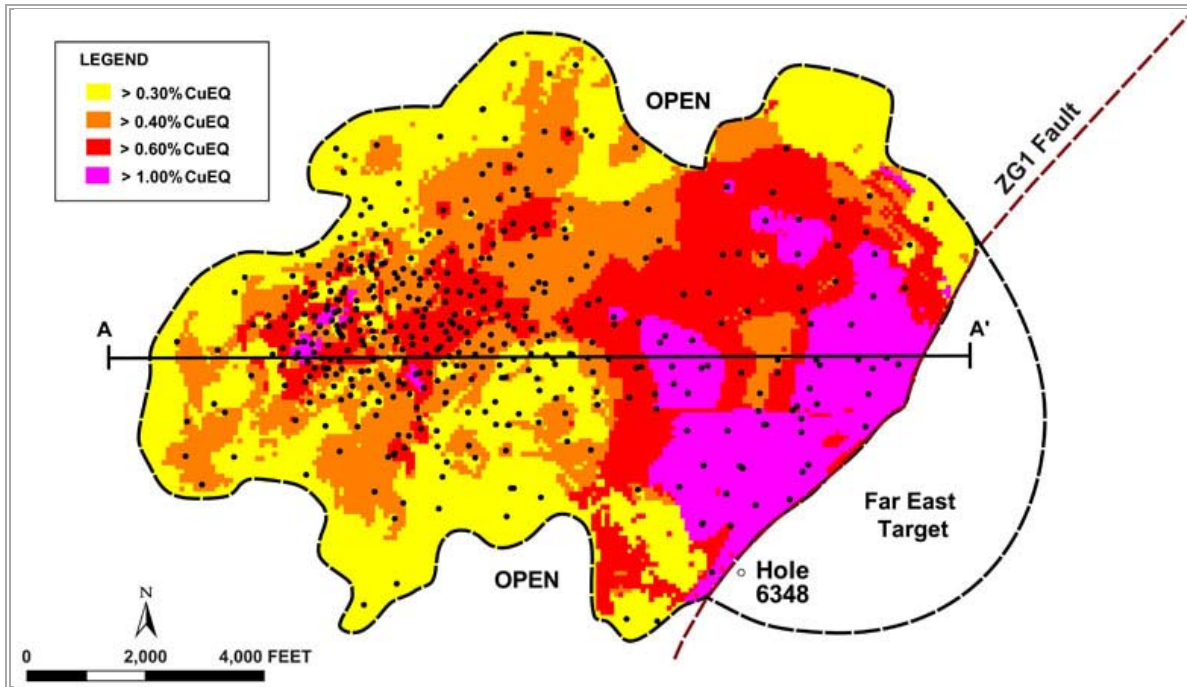
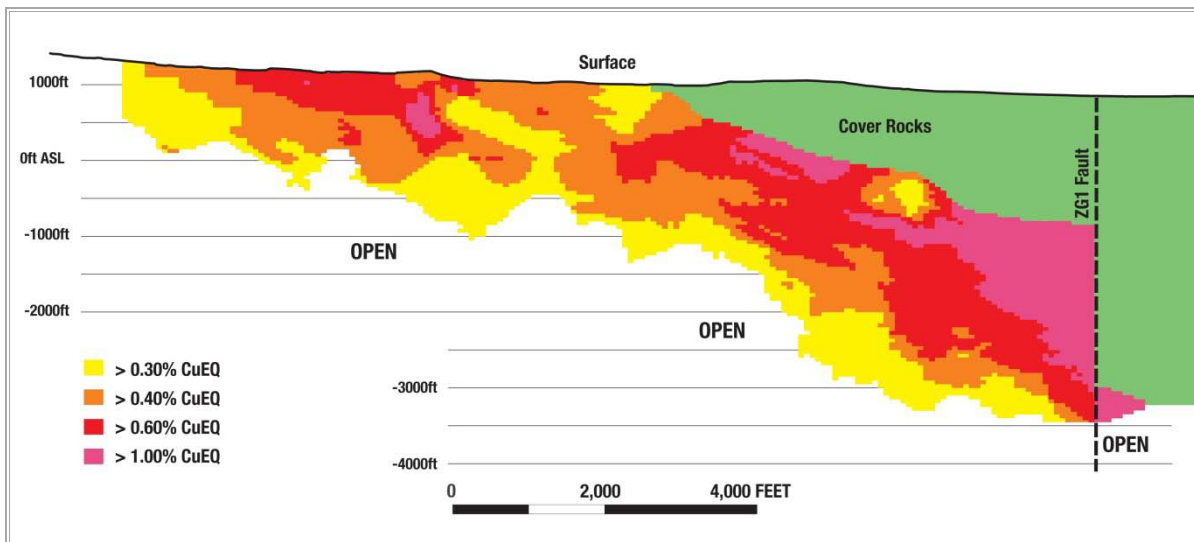


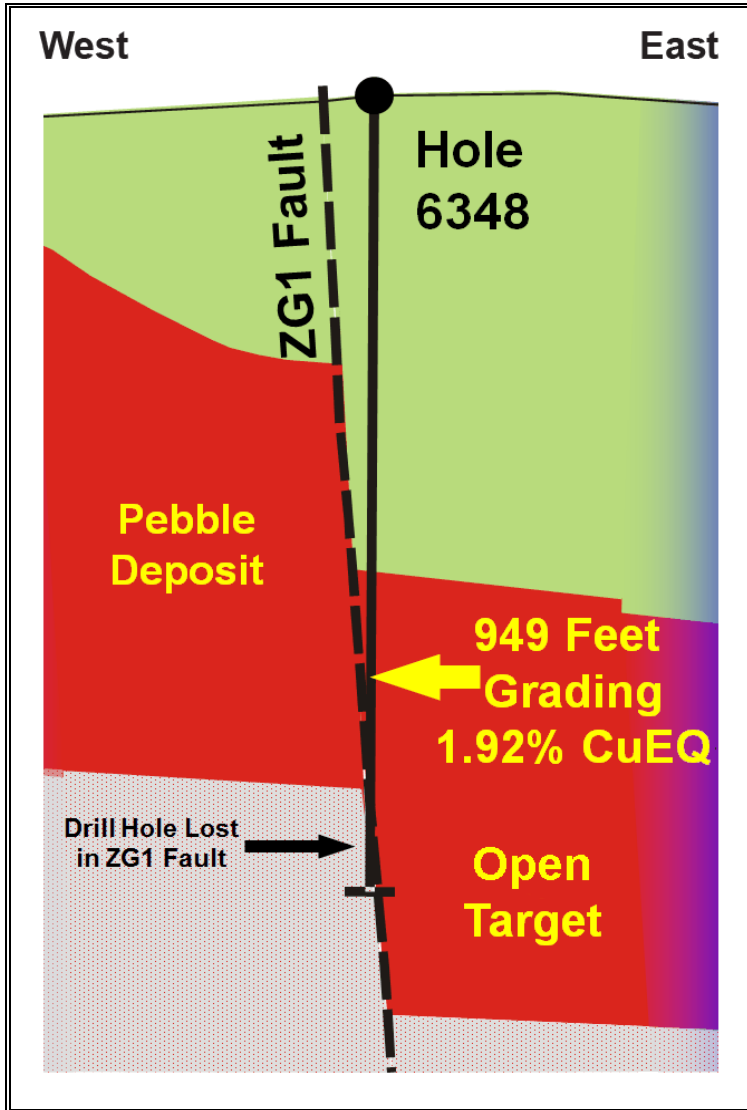
Figure 1.4.4 Cross-section A-A' of Pebble Deposit Showing Grade as CuEQ



**1.4.4 EXPLORATION HISTORY AND TARGETS**

Numerous compelling exploration targets exist within the Pebble property claim boundary. Immediately adjacent to the Pebble deposit and east of the resource bounding ZG1 fault is the high-grade intersection in drill hole 6348 (949 ft at 1.92% CuEQ comprised of 1.24% Cu, 0.74 g/t Au, and 0.042% Mo; see Table 1.6.1 for details of CuEQ calculations.). The area to the east of this intersection remains completely open (Figure 1.4.5).

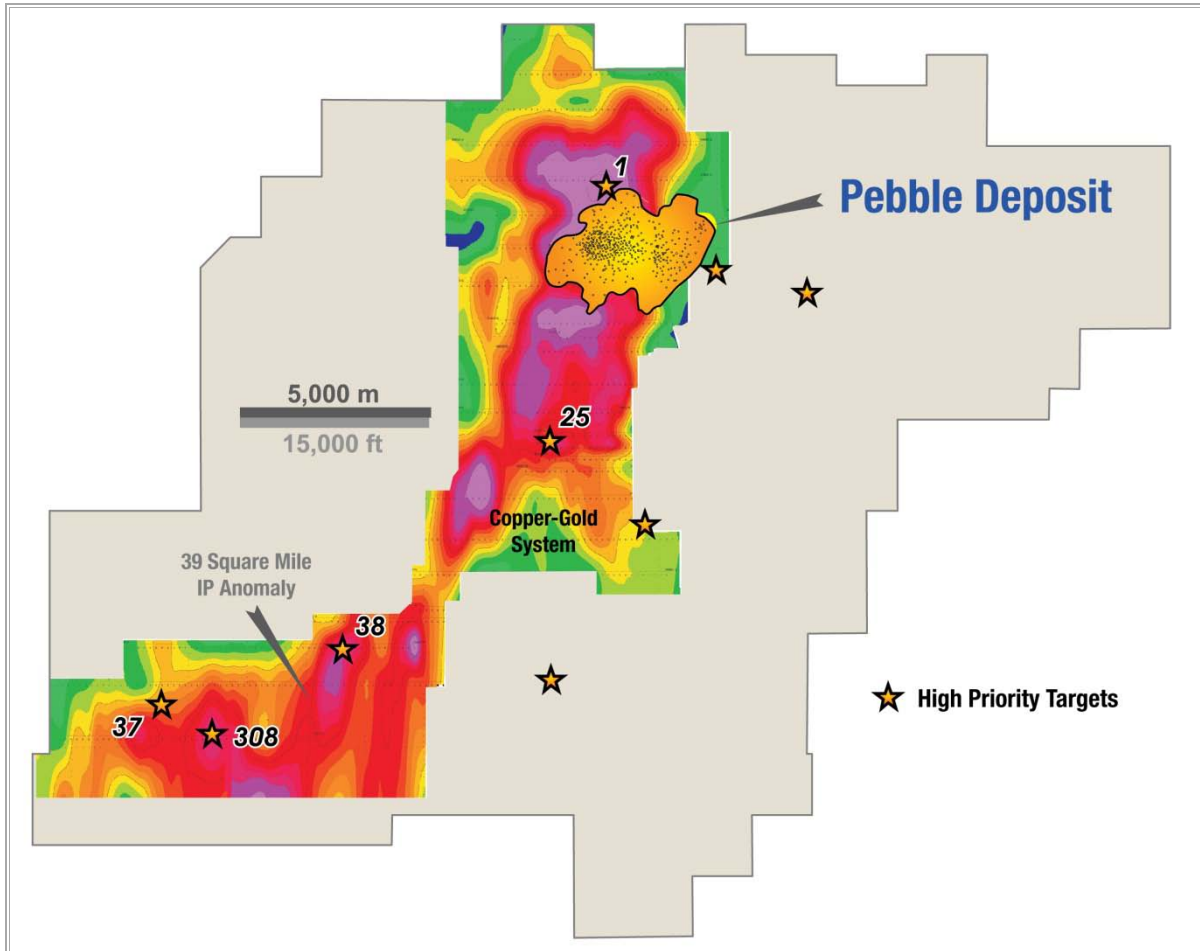
**Figure 1.4.5 East-West Section across DDH 6348**



Outside of the Pebble deposit, two seasons of exploration drilling have identified numerous zones of copper, gold, molybdenum and silver mineralization on the property. These include the 'No. 1' gold showing, the '25 zone', the '52 Porphyry zone', the '308 Porphyry zone', the '37 Skarn zone' and the '65 zone'. In addition, several zones of strong alteration and elevated levels of copper-molybdenum or gold-zinc-silver indicate new separate porphyry style mineralizing centres have been intersected.

Geological, geochemical and geophysical surveys have been conducted in the Pebble Project area by Cominco between 1985 and 1997, by Northern Dynasty between 2001 and 2007, and since mid-2007 by the Pebble Partnership. The property has been mapped geologically at a scale of 1:10,000, and a detailed map based on drill hole data has been constructed for the Pebble deposit area.

**Figure 1.4.6 Pebble Property Mineral Occurrences and IP Map**



Dipole-dipole IP surveys covering 95 line-miles (153 km) have been completed on the property since 1988. A broad chargeability anomaly covering 35 mi<sup>2</sup> (91 km<sup>2</sup>) and comprised of 11 distinct higher chargeability centres encompasses known mineralization on the property. Ground and airborne magnetometer surveys have also been completed over the property, as well as a magnetotelluric survey. The magnetotelluric survey was undertaken in 2007 and covered a total of 2,386 line-miles (3,840 km) in two flight block configurations:

- a regional block covering an area of about 19 x 7.5 mi (30 x 12 km) at a line spacing of 0.9 miles (1.5 km);
- a more detailed block which covered the Pebble property using a line spacing of 820 ft (250 m); and,
- In 2010, a 6,452 line-km airborne ZTEM and magnetometer geophysics was completed.



A total of 7,337 geochemical samples were collected by Cominco between 1988 and 1995. Northern Dynasty collected an additional 1,026 soil samples between 2001 and 2003. These sampling programs have outlined high-contrast, coincident anomalies in gold, copper, molybdenum and other metals in an area that measures 9 km (5.6 mi) north-south by up to 4 km (2.5 mi) east-west, with strong but smaller anomalies in several outlying zones. No geochemical surveys have been completed since 2003.

## 1.5 DRILLING, SAMPLING AND DATA VERIFICATION

### 1.5.1 DRILLING

Extensive drilling has taken place at the Pebble Project over 15 different years. A total of 948,638 ft (289,145 m) has been drilled in 1,158 holes on the Pebble property to October 2010 as summarized in Table 1.5.1.

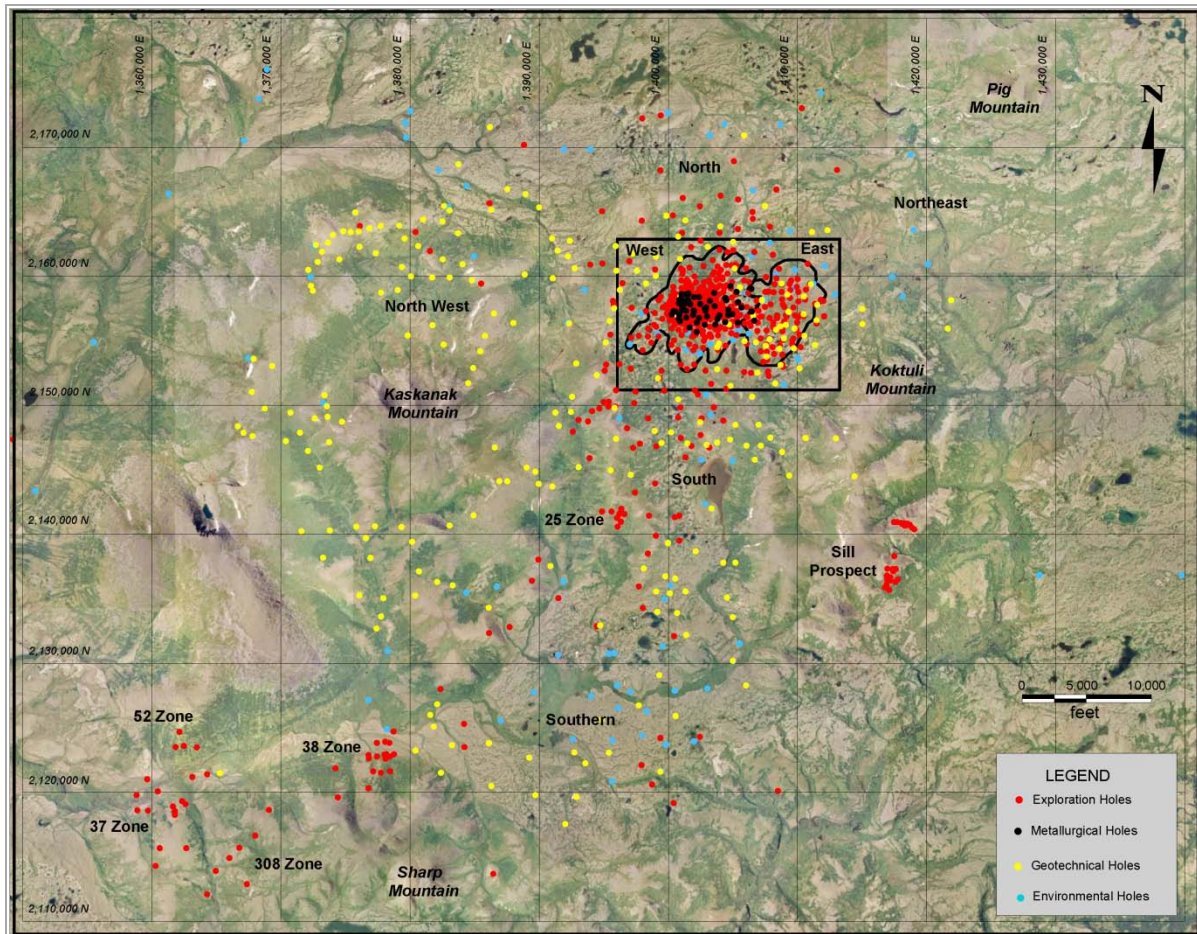
Reconnaissance exploration by Cominco in the Pebble area in 1986 was a continuation of regional exploration initiated in the mid-1980s. Examination and sampling of several color anomalies in 1987 yielded the Pebble discovery outcrop, which was of uncertain affinity. The 1988 exploration program included the drilling of 24 diamond drill holes at the Sill epithermal gold prospect, soil sampling, geological mapping and the drilling of two diamond drill holes on the Pebble target. Work continued in 1989, with an expanded soil sampling program, an IP survey and the completion of 12 diamond drill holes at the Pebble target and 15 additional holes at the Sill prospect. Although limited in scope, the IP survey displayed a response characteristic of a large porphyry copper system. This interpretation was validated by subsequent drilling at the Pebble target, which intercepted long intervals of porphyry-style copper and gold mineralization. In 2004, drilling by Northern Dynasty identified a significant, new porphyry centre on the eastern side of the Pebble deposit (the Pebble East zone) beneath a cover of non-mineralized Tertiary rocks that becomes progressively thicker to the east.

All drill collars have been surveyed using either differential GPS or total station measurements, and a digital terrain model for the site has been generated by photogrammetric methods. All post-Cominco drill holes have been surveyed down hole, typically using a single shot magnetic gravimetric tool. A total of 940 holes are drilled vertically (-90 degrees) and 218 are inclined from -42 to -85 degrees at various azimuths.

**Table 1.5.1 Summary of Drilling in the Pebble Region to October 2010**

Company	Area	No. of Holes	Length (ft)	Length (m)
Cominco	Pebble Deposit	117	62,930	19,181
Cominco	Rest of Property	47	12,811	3,905
Northern Dynasty /Pebble Partnership	Pebble Deposit	484	698,296	212,841
Northern Dynasty /Pebble Partnership	Rest of Property	503	169,151	51,557
FMM	Rest of Property	7	5,450	1,661
<b>Total</b>		<b>1,158</b>	<b>948,638</b>	<b>289,145</b>

Figure 1.5.1 Location of Drill Holes – Pebble Region



Of the core drilled since 2002, 52% is 2.5” (63.5 mm) HQ, 38% is 1.875” (47.6 mm) NQ and 10% is 3.35” (85 mm) PQ diameter. Core recovery is generally very good. As measured since 2004 on a drill run basis, it averages 98% for Cretaceous rocks used in the mineral resource estimate. Almost 70% of Cretaceous rock intervals in the study have core recoveries of 100%. Overburden in delineation and infill drill holes is typically drilled by tricone bit with no core recovery; however, overburden is recovered by triple-tube coring in some engineering holes. A relatively small amount of reverse circulation drilling has been undertaken in certain hydrology monitoring holes.

### 1.5.2 SAMPLING METHOD AND APPROACH

Core logging and processing are carried out in a secure compound at the Pebble Project site office in Iliamna by, or under the supervision of, site geologists and/or engineers. Core processing includes the recording of geological parameters, including rock type, alteration, veins, mineralization and structure; geotechnical data on fractures, joints, veins, faults, RQD, rock hardness and related physical characteristics; density measurements approximately every 100 ft (30 m); and photography of each box of drill core.

All Cretaceous core intervals since 2002 and all Tertiary waste rock intervals drilled and recovered since early 2004 have been sampled and assayed. Samples of Cretaceous drill core have been taken by sawing the core in half lengthwise and typically average 10 ft (3 m) in length. Tertiary waste rock samples and some Cretaceous samples from metallurgical drill holes have generally been taken by a 20% off-centre saw method. Tertiary samples typically range up to 20 ft (6.1 m) in length. All samples are sent to independent third-party laboratory ALS Minerals (formerly Chemex) for preparation and analysis, except in 1997 and 2003 when they were sent to Cominco Exploration Research and SGS Minerals laboratories respectively. The core remaining after sampling for geochemical analysis is archived in a secure compound located near the logging facility.

### 1.5.3 SAMPLE PREPARATION, ANALYSIS AND SECURITY

As the Pebble Project has progressed, chemical analysis methods, quality assurance and quality control (QA/QC) and sample security procedures have also progressed to meet industry standards of the day.

Drill core is boxed and depth markers inserted at the drill site. The core is transported daily from the drill rig by helicopter to a secure compound adjacent to the Iliamna airport, where core is logged and sampled. Since 2002, split core samples have been shipped by air charter from Iliamna to Anchorage, and then by commercial air freight to Fairbanks where it is delivered to the sample preparation laboratory. After preparation, samples are shipped by commercial air freight to the analytical laboratory.

The following protocol for preparation of samples for analysis has been in place since 2004:

- dry, weigh and crush entire sample to 70% <10 mesh (2 mm), split either a 1,000 g (Cretaceous) or 250 g (Tertiary) sub-sample and pulverize to 95% <200 mesh (75 µm).

Similar sample preparation procedures were employed prior to 2004. Since 2002, copper, molybdenum, silver and several additional elements have been determined by multi-element analysis by ICP-AES/MS after acid digestion. Prior to 2002, Cominco used a combination of single element Aqua Regia digestion AAS determinations and multi-element ICP-AES. In all cases, fire assay, with AAS or gravimetric finish, has been used for the determination of gold.

### 1.5.4 DATA VERIFICATION

Northern Dynasty implemented and maintained an effective QA/QC system consistent with industry best practice. This system has been continuously maintained under the Pebble Partnership. This program is in addition to the QA/QC procedures used internally by the analytical laboratories.

Since 2004, the Pebble QA/QC program has been overseen by independent specialist consultants providing ongoing monitoring, facility inspection and timely reporting on the performance of standards, blanks and duplicates in the drill hole sampling and analytical program. The results of this program indicate that analytical results are of a high quality suitable for use in detailed modelling and resource evaluation studies.

Standard reference materials have been inserted into the Cretaceous rock sample stream in the field at a rate of approximately one sample for every 20 since 2002. Standard performance has been monitored

over time against the concentration of the control elements. In 2008, a set of ten matrix-matched certified reference materials were produced from Pebble drill core rejects specifically for the purpose of analytical control of copper, gold, molybdenum and silver. These Pebble specific standards have been in use since 2009.

Random duplicate samples have been taken since 1989 for inter-laboratory (or intra-laboratory) duplicate analysis. From 2004 onward, the samples to be duplicated have been split from the coarse reject at a rate of one sample in 20 by ALS Minerals in Fairbanks and forwarded to Acme Analytical in Vancouver for pulverization and analysis by similar methods to those used by the primary laboratory. The approximately 2,000 coarse reject, inter-laboratory duplicate assay results from 2004 to 2009 match reasonably well; the correlation coefficients are 0.96 for gold, 0.98 for copper and 0.98 for molybdenum.

Density measurements have been made at 100 ft (30 m) intervals within continuous rock units by the water submersion method since 2003.

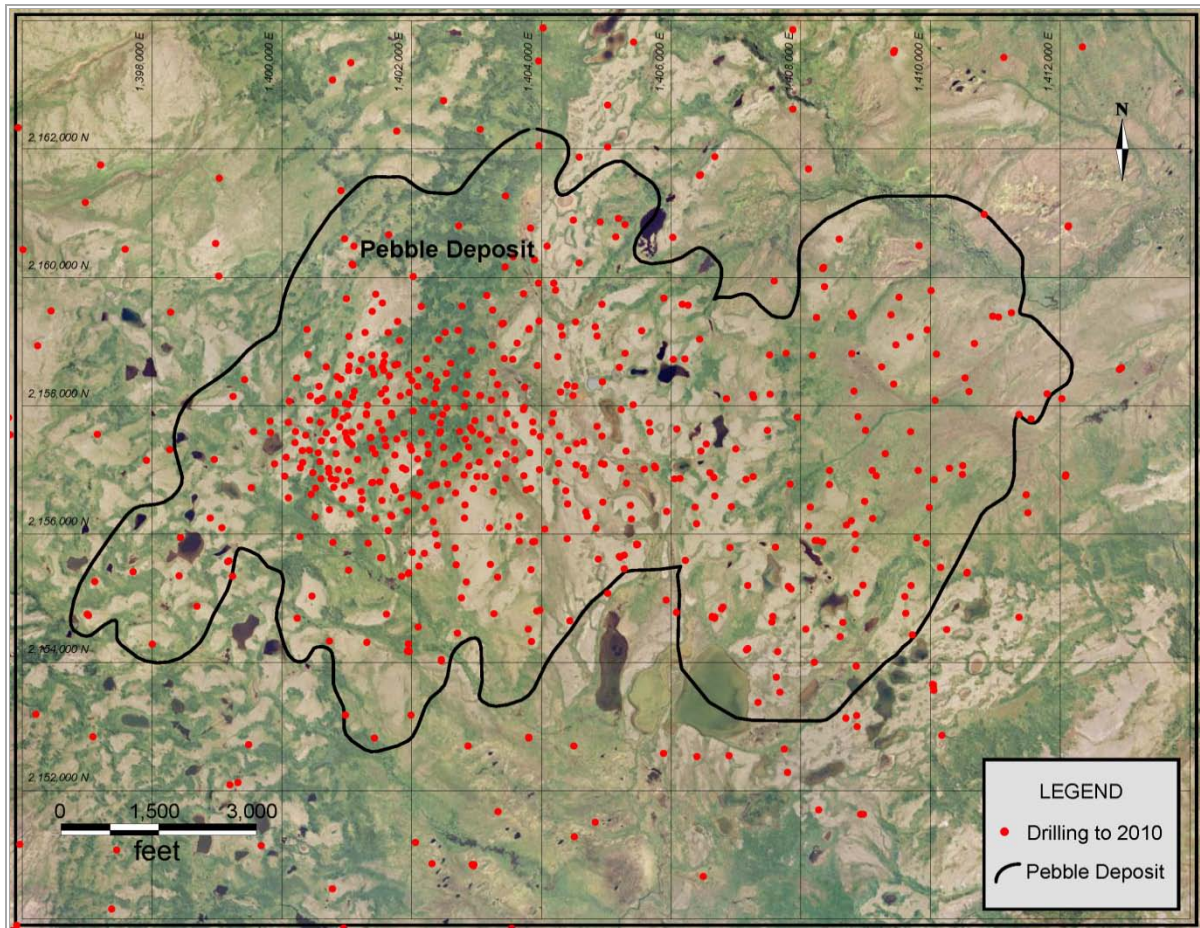
During the 2008 and 2009 field seasons, all holes drilled at the Pebble Project since inception in 1988 were resurveyed to obtain a complete set of consistently acquired collar survey data. The re-surveys were taken to the top of tundra over the centre of the drill hole. Where a drill hole could not be located, the resurveyed coordinate was taken at the original drill collar location and the elevation re-established in the new system.

Compiled drill data has been subject to validation and verification reviews since 2001. This includes work done independently by Norwest in 2004, on an ongoing basis between 2002 and 2009 by Northern Dynasty and the Pebble Partnership, and through independent analytical monitoring by consultants since 2004.

A significant amount of diligence and analytical QA/QC for copper, gold and molybdenum has been completed on samples used in the February 2010 mineral resource estimate. This work indicates that the copper, gold and molybdenum analytical results are acceptable for use in geological and resource modelling of the Pebble deposit.

Wardrop believes that the copper, gold and molybdenum analytical results are acceptable for use in geological and resource modelling for the Pebble deposit.

**Figure 1.5.2 Location of Drill Holes – Pebble Deposit Area**



## 1.6 MINERAL RESOURCE ESTIMATION AND HISTORY

Initial estimates of mineral resources within the Pebble deposit were made by Cominco. Subsequently, Northern Dynasty reported mineral resource estimates for the Pebble West zone based on work undertaken in 2002, 2003 and 2004, and for the Pebble East zone based on work undertaken in 2005 and 2006. Northern Dynasty also reported a mineral resource estimate for the Pebble East zone based on work undertaken by the Pebble Partnership in 2007. In December 2008, an estimate of total mineral resources for the entire Pebble deposit (including both Pebble East and Pebble West) was announced based on drilling up to June 2008.

The current Pebble mineral resource estimate represents the culmination of seven years of geological and geostatistical analysis and is based on drill data to September 2009. Principal economic metals estimated into the blocks are copper, gold and molybdenum. The updated mineral resources are reported within a defined volume at various cut-off grades (see Table 1.6.1).

**Table 1.6.1 Current Pebble Project Resources (February, 2010)**

Cut-off (% CuEQ)	CuEQ (%)	Mt	Cu (%)	Au (g/t)	Mo (ppm)	Cu (Bib)	Au (Moz)	Mo (Bib)	CuEQ (Bib)
<b>Measured</b>									
0.30	0.65	527	0.33	0.35	178	3.8	5.9	0.21	7.6
0.40	0.66	508	0.34	0.36	180	3.8	5.9	0.20	7.4
0.60	0.77	277	0.40	0.42	203	2.4	3.7	0.12	4.7
1.00	1.16	27	0.62	0.62	301	0.4	0.5	0.02	0.7
<b>Indicated</b>									
0.30	0.80	5,414	0.43	0.35	257	51.3	60.9	3.07	95.5
0.40	0.85	4,891	0.46	0.36	268	49.6	56.6	2.89	91.7
0.60	1.00	3,391	0.56	0.41	301	41.9	44.7	2.25	74.8
1.00	1.30	1,422	0.77	0.51	342	24.1	23.3	1.07	40.7
<b>Measured + Indicated</b>									
0.30	0.78	5,942	0.42	0.35	250	55.0	66.9	3.28	102.2
0.40	0.83	5,399	0.45	0.36	260	53.6	62.5	3.09	98.8
0.60	0.98	3,668	0.55	0.41	293	44.5	48.3	2.37	79.2
1.00	1.29	1,449	0.76	0.52	341	24.3	24.2	1.09	41.2
<b>Inferred</b>									
0.30	0.53	4,835	0.24	0.26	215	25.6	40.4	2.29	56.5
0.40	0.66	2,845	0.32	0.30	259	20.1	27.4	1.62	41.4
0.60	0.89	1,322	0.48	0.37	289	14.0	15.7	0.84	25.9
1.00	1.20	353	0.69	0.45	379	5.4	5.1	0.29	9.3

**Note 1:** Copper equivalent calculations for this resource estimate used metal prices of US\$1.85/lb for copper, US\$902/oz for gold and US\$12.50/lb for molybdenum, and metallurgical recoveries of 85% for copper 69.6% for gold, and 77.8% for molybdenum in the Pebble West area and 89.3% for copper, 76.8% for gold, 83.7% for Mo in the Pebble East area. Revenue is calculated for each metal based on grades, recoveries and selected metal prices: accumulated revenues are then divided by the revenue at 1% Cu. Recoveries for gold and molybdenum are normalized to the copper recovery as shown below:

$$\text{CuEQ (Pebble West)} = \text{Cu \%} + (\text{Au g/t} \times 69.6\%/85\% \times 29.00/40.79) + (\text{Mo \%} \times 77.8\%/85\% \times 75.58/40.79)$$

$$\text{CuEQ (Pebble East)} = \text{Cu \%} + (\text{Au g/t} \times 76.8\%/89.3\% \times 29.00/40.79) + (\text{Mo \%} \times 83.7\%/89.3\% \times 75.58/40.79)$$

**Note 2:** By prescribed definition, “Mineral Resources” do not have demonstrated economic viability. Measured and Indicated Resources are that part of a mineral resource for which quantity and grade can be estimated with a level of confidence sufficient to allow the application of technical and economic parameters to support mine planning and evaluation of the economic viability of the project. Inferred Mineral Resources are that part of a mineral resource for which quantity and grade can be estimated on the basis of geological evidence and limited sampling and reasonably assumed, but not verified, geological and grade continuity. Inferred Mineral Resources are considered to be too speculative to allow the application of technical and economic parameters to support mine planning and evaluation of the economic viability of the project. The mineral resources fall within a volume or shell defined by long-term metal price estimates of US\$2.50/lb for copper, US\$900/oz for gold and US\$25/lb for molybdenum.

**Note 3:** For bulk underground mining, cut-offs such as 0.60% CuEQ, are typically used for porphyry deposit bulk underground mining operations at copper porphyry deposits located around the world. A 0.30% CuEQ cut-off is considered to be comparable to that used for porphyry deposit open pit mining operations in the Americas. All mineral resource estimates and cut-offs are subject to a feasibility study.

**Note 4:** CIM definitions were followed for classification of Mineral Resources

For the current resource model, the Pebble deposit has been partitioned into domains of like statistical characteristics based on grade, lithology and alteration for copper, Au and Mo. These domains have then been modified by:

- the East/West-trending, post-ore ZE normal fault which displaces mineralized Cretaceous rock up to 1,000 ft sub-vertically;
- the unconformity surface marking the boundary between the Cretaceous and overlying unmineralized Tertiary rock;
- a North-South-trending 'East-West Divide,' which marks a slight change in the dip of the mineralized package; and,
- in the case of copper only, a volume encompassing leached material and a volume encompassing supergene material.

All domains, with the exception of the East-West Divide, are respected as hard boundaries for sample search strategies and block interpolation.

Raw drill hole data has been capped using outlier analysis, and composited and coded to 50 ft lengths within domain boundaries. Variograms have been constructed for each domain and modelled using Supervisor<sup>®</sup> software. Copper, gold and molybdenum grades have been interpolated into 75 ft x 75 ft x 50 ft blocks by ordinary kriging using a three pass approach in which search ranges are successively increased. Grades and other metrics have also been estimated into the model for metallurgical, comminution or environmental purposes.

Estimated blocks have been assigned a provisional mineral resource classification based largely on average distance to drill holes. Criteria for assignment are as follows:

- blocks within 600 ft laterally and 300 ft vertically from a drill hole have been provisionally classed as Inferred;
- blocks for which the average distance to the nearest three holes is less than or equal to 500 ft have been provisionally classed as Indicated; and
- blocks for which the average distance to the nearest three holes is less than or equal to 250 ft have been provisionally classed as Measured.

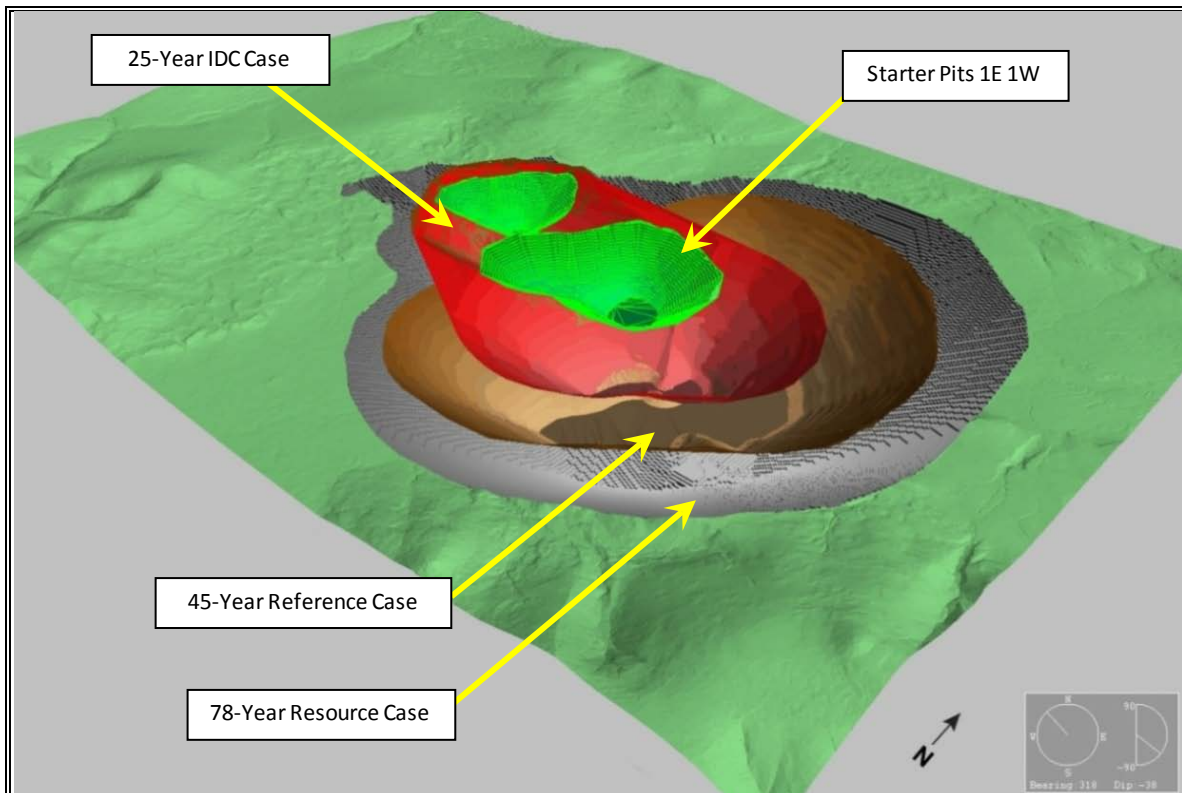
Classifications have been manually adjusted to eliminate isolated blocks of one classification surrounded by blocks of another. Wireframe models have been constructed which enclose the main volumes of each classification, and these wireframes have been used to assign the class codes within them.

A rigorous test of the potential for economic extraction has been applied to the mineralization in the form of a pit optimization study. Those blocks not contained within this volume have been eliminated from the resource tabulation.

## 1.7 MINING

Open pit mining plans have been prepared for each of the three Pebble Project development cases presented in this Preliminary Assessment, including the 25-year IDC Case, the 45-year Reference Case and the 78-year Resource Case. These designs incorporate extensive geotechnical investigations and include pre-production stripping, haul road locations and principal phases of mining. The starter pit shells, as well as those for each of the development cases are shown in Figure 1.7.1.

**Figure 1.7.1 Pit Shells for All Development Cases**



Mine schedules have been developed for the life-of-mine in each development case, setting out volumes of waste and ore mined, densities, tons, dilution, grades of contained metals (copper, gold, molybdenum) and material hardness. A key aspect of these schedules is the annual plant throughput tonnage, which is defined by the grindability of the ore. The rate of ore production in any given year is derived by that tonnage which utilizes all available energy for which the plant has been designed (909 GWh/a). The maximum processing rate has been limited to 275,000 tons per day as determined by the SAG mill hydraulic limit. Accordingly, the annual production rate fluctuates over the mine life as the hardness of the ore varies, particularly the amount of softer Pebble East ore increases. The average production rate in the 25-Year IDC Case will be 218,000 tons per day, a figure which increases to 229,000 tons per day in both the 45-year Reference Case and in the 78-year Resource Case.

Open pit mine schedules for the 25-year IDC Case, the 45-year Reference Case and the 78-year Resource Case provide input to the financial analysis in this Preliminary Assessment; however,



underground mining of the eastern portion of the Pebble deposit remains a viable development option. Ongoing studies indicate that block caving is a feasible mining method for the higher-grade resources in the Pebble East zone. Underground development schedules, production schedules and capital and operating costs for a block cave mining rate of 150,000 tons per day have been prepared.

**1.7.1 OPEN PIT MINING**

**OPEN PIT GEOTECHNICAL**

Geotechnical investigations to aid in pit designs have been conducted at the Pebble Project site between 2004 and 2008. These investigations include 215 drill holes, 320 test pits, 35 seismic lines and an aerial photographic interpretation of the project site.

The slope geometry for an open pit mine can typically be described in terms of bench geometry, inter-ramp slope angle and overall slope angle. An overall slope angle of 39° has been used for the pit optimization.

For the 25-year IDC Case, mining will be initiated with progression through two phases – East and West. Mining will continue in both areas until the final West pit bottom is reached; thereafter, mining will continue in the East pit only. Subsequent pit phases have been designed for mining up to and including the 45-year Reference Case and the 78-year Resource Case.

**Figure 1.7.2 Cross Section Showing Open Pit Phase Sequence**

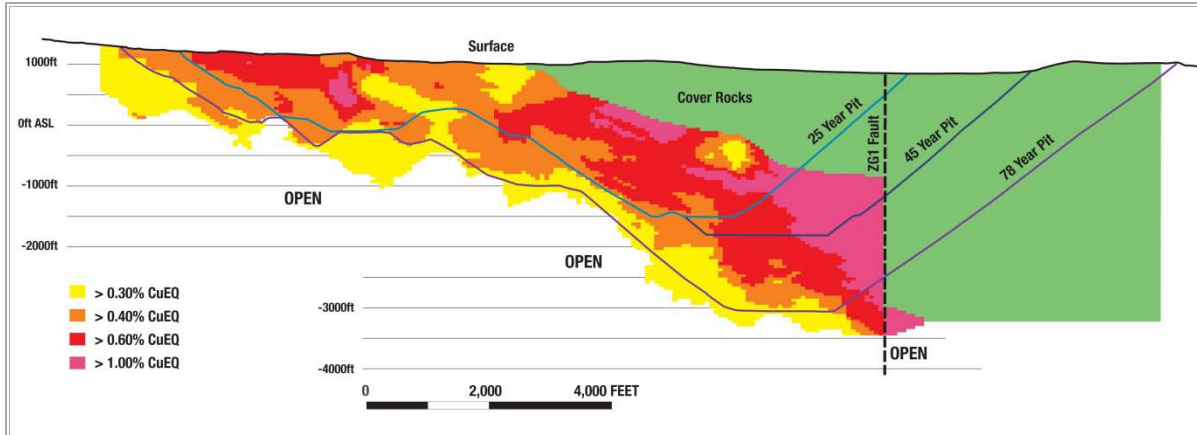
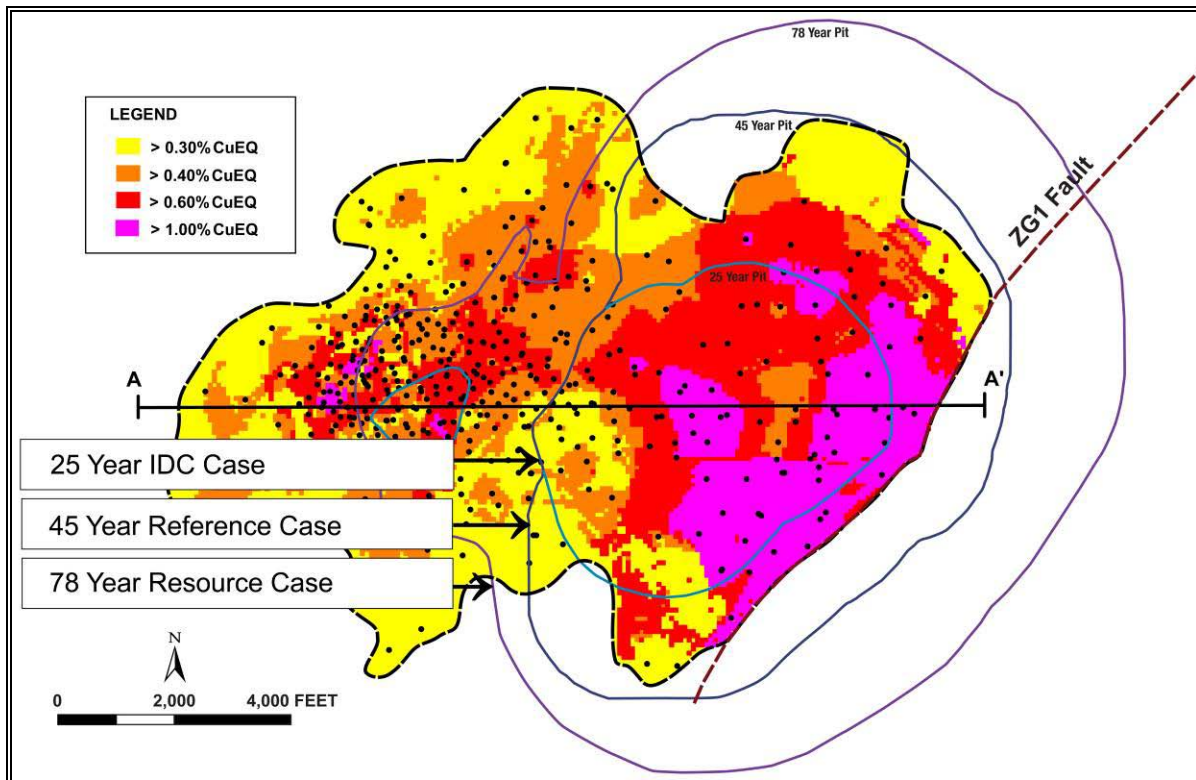


Figure 1.7.3 Open Pit Phase Sequence at 0 ft amsl



#### OPEN PIT OPERATION AND EQUIPMENT

Key operating assumptions for open pit mining of the Pebble deposit include:

- 350 days of operation per year;
- two 12-hour shifts per day;
- two meal breaks per shift (one 40 minutes and one 20 minutes);
- five days per year lost due to adverse weather;
- autonomous trucking; and
- In Pit Crushing and Conveying (IPCC) starting in Year 16.

Estimates of total mining costs using a conventional drill, blast and truck-haul mining method with 400 ton trucks, 73 yd<sup>3</sup> shovels and 12.25" blasthole drills demonstrate a positive correlation between increasing mine life and case value.

#### WASTE STOCKPILES AND TRUCK HAULAGE

Waste stockpiles at the Pebble Project will be located within 1,000 to 1,500 ft of the pit rim defined by the 78-year Resource Case. Exceptions will be to the southeast due to higher topography and to the

northwest where operational infrastructure is located. Haul roads for ore will exit from the north rim of the pit, while haul roads for waste will exit from the north, east and south sides of the pit. The western portion of the south dump will backfill the Pebble West open pit. Waste stockpiles will be constructed as close as is practicable to the open pit to reduce the length of flat haul from the pit rim to the start of the stockpile ramp.

Haulage profiles have been calculated and used for truck hour calculations in the open pit operating cost estimates for the 25-year IDC Case and the 45-year Reference Case. Haulage profiles have not been calculated for the 78-year Resource Case, but an additional mining cost of \$0.50/ton has been applied in the financial evaluation to accommodate greater haulage distances.

Assumptions for autonomous trucking performance and labour have been taken from information available in the public domain and based on an estimate of future technology benefits being attained.

In Year 16 of the open pit mine life, a bench on 400 ft elevation provides an opportunity for the installation of an IPCC station.

**MAIN EQUIPMENT**

Equipment requirements for the 25-year IDC Case and the 45-year Reference Case have been derived. The relationship between strip ratio and equipment expenditures over time up to 45 years has been used to forecast equipment costs for the 78-year Resource Case.

The main equipment requirements by year for the 45-year Reference Case are summarized in Table 1.7.1.

**Table 1.7.1 Main Equipment Requirements**

	Mine Life Horizons (Year)									
	0	5	10	15	20	25	30	35	40	45
Drills 12.25"	5	8	9	16	16	17	19	19	11	6
Shovels 73 yd <sup>3</sup>	2	3	4	6	7	7	8	8	4	2
Hydraulic Shovels 53 yd <sup>3</sup>	1	2	2	3	3	3	2	2	1	1
Wheel Loaders 53 yd <sup>3</sup>	1	2	2	3	3	3	2	2	1	1
Autonomous Trucks 400 ton	11	21	30	82	88	104	130	158	84	48

The mining fleet will increase to match stripping ratio requirements to deliver scheduled ore to the metallurgical plant in alignment with each of the development cases. The 45-year Reference Case has a mining rate of approximately 1,000,000 tons per day between years 25 and 35. The value in applying the IPCC technology to reduce the haul truck fleet in later years is apparent.

## EQUIPMENT SCHEDULE OF ACQUISITION

Equipment purchase schedules have been determined by the production schedule, equipment productivity and equipment operating life cycles. The estimate was prepared using a just-in-time approach.

## OPEN PIT MINING COSTS

### *Capital Cost Estimate*

The capital cost estimate for mining equipment is based on vendor quotes. Additional allowances have been made for special modifications (e.g. Arctic package), transport and erection at site. Freight cost from Seattle to site has been estimated and captured in the G&A section on a \$/ton basis.

Additional capital for autonomous haul truck conversion has not been included. Currently, autonomous haul trucks are produced and sold with the flexibility to be driven by an operator. The unquantified savings from the expected removal of this capability are assumed to offset any additional capital requirement.

Spare parts initial stock for all mining equipment has been included in the capital estimate and calculated by applying an 8% value factor to the main and major ancillary equipment purchase value for the first three years of the mining plan.

The capital expenditure cash flow for each of the three development cases in this Preliminary Assessment has been estimated for each year of the mine life. Initial capital for mining equipment is \$247 million, excluding indirect costs and owners costs.

### *Operating Cost Estimate*

Mining operating cost estimates have been prepared in detail for the 25-year IDC Case and the 45-year Reference Case. For the 78-year Resource Case, two approaches have been taken to derive operating costs: where costs remain fixed, average values derived from the 45-year Reference Case have been used or escalated based on cost trends; where costs are clearly a function of a value, such as strip ratio, this relationship has been used.

Table 1.7.2 shows the management labour complement.

**Table 1.7.2 Operational Management Complement**

Position	Number of Employees
Mine Management	1
Technical Services	39
Operations	19
Maintenance	17
<b>Total</b>	<b>76</b>

The machine operator and maintenance staff complement reflects employees on payroll (as opposed to on site) and aligns with a two-week-on/one-week-off shift schedule. The duration of each shift is 12 hours. The number of employees required to support a position is approximated at 3.12, and the ratio of operator labour complement to maintenance labour complement is set at 1.5:1. Table 1.7.3 shows the mining operator and maintenance labour on payroll for the 45-year Reference Case.

**Table 1.7.3 Operator and Maintenance Staff on Payroll**

	Yr 0	Yr 5	Yr 10	Yr 15	Yr 20	Yr 25	Yr 30	Yr 35	Yr 40	Yr 45
Operators	61	93	154	239	248	269	294	323	167	106
Maintenance	62	95	159	288	299	332	378	438	230	147
<b>Total</b>	<b>123</b>	<b>188</b>	<b>313</b>	<b>527</b>	<b>547</b>	<b>601</b>	<b>672</b>	<b>761</b>	<b>397</b>	<b>253</b>

\* The labour required to operate the IPCC system is not included in this estimate.

*Summary*

Mining operating costs are shown in Table 1.7.4 for the 45-year Reference Case. Estimated values are real and undiscounted.

**Table 1.7.4 Total Mining Operational Cost for 45 year Case**

Mining Cost	LOM 45 Years Autonomous Trucks and IPCC	
	\$M	\$/ton
Drilling	921	0.08
Blasting	1,992	0.17
Loading	1,552	0.13
Transport	7,865	0.68
Ancillary Equipment	1,470	0.13
Other Support Equipment	195	0.02
Dewatering	596	0.05
Rehandling	97	0.01
Labour	2,858	0.25
<b>Total</b>	<b>17,546</b>	<b>1.52</b>

Table 1.7.5 summarizes mining costs per dry ton for the 45-year Reference Case. Estimated rates are real and undiscounted.

**Table 1.7.5 Total Mining Operational Cost per Time Horizon**

Case	Unit	Mine Life Horizons (Year)										LOM Avg
		0	5	10	15	20	25	30	35	40	45	
Autonomous & IPCC*	\$/ton	1.22	1.13	1.11	1.42	1.38	1.44	1.60	1.84	1.98	2.13	1.52

\* The mining cost does not include the operating cost per ton of ore for IPCC system.

## 1.7.2 UNDERGROUND MINING

It should be noted that mine development at Pebble following the initial 25 years of production could be undertaken via underground block caving. While underground development of mineral resources in the Pebble East zone is currently considered economically viable at long-term metal prices, it is expected that additional investigations will be undertaken during the initial 25-year mine life to determine whether open pit or block caving development presents the best opportunity for subsequent phases of mining, based upon a broad range of factors.

### UNDERGROUND MINE PLANNING

Underground production schedules have been prepared using a mining rate of 150,000 tons per day. Grade and production rate have been optimized by combining individual mining block schedules, and a life-of-mine production schedule has been prepared which maximizes grade and production rate sustainability.

Conceptual mine designs have been developed along with a high-level pre-production development and construction schedule so that pre-production capital, sustaining capital, and operating costs can be estimated.

### MINE DESIGN

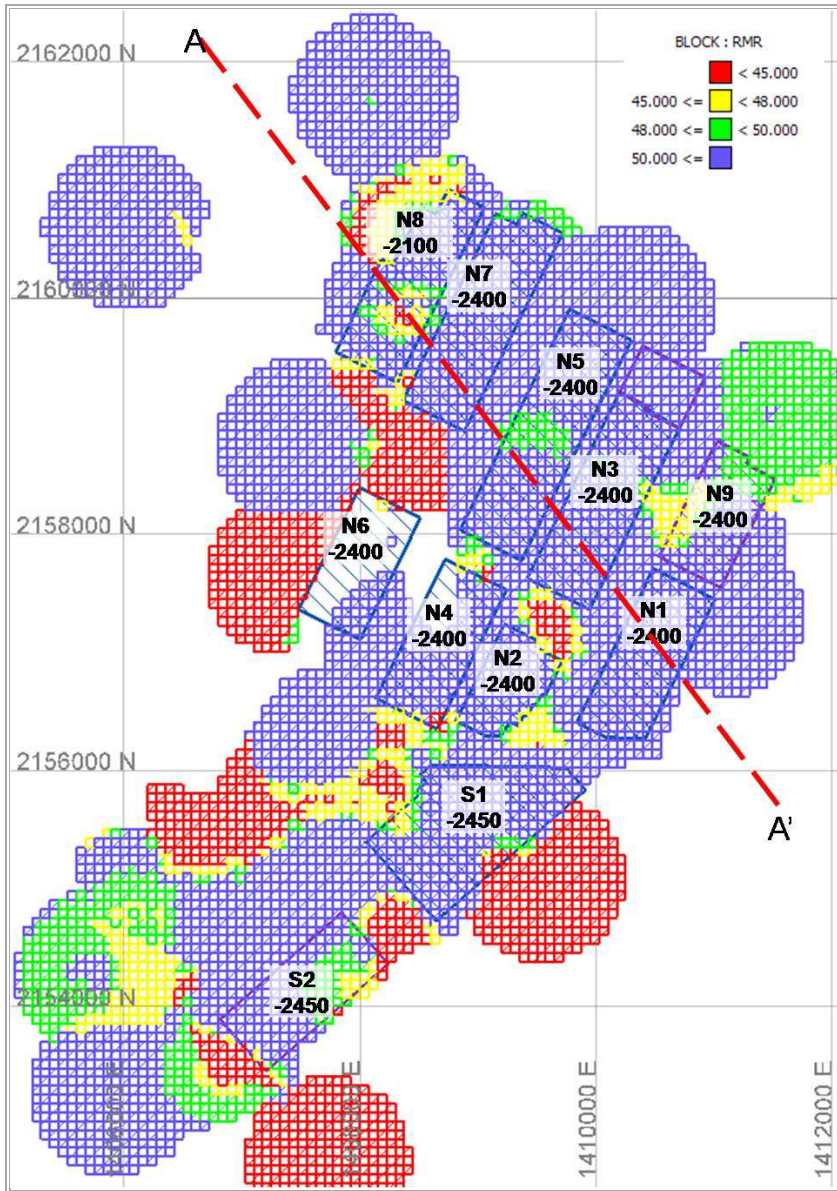
Design criteria employed in the underground block cave design utilize a drawpoint spacing of 55 ft in an offset herringbone pattern on the extraction level. All extraction levels for the 11 mining blocks are placed in ground with a Rock Mass Rating (RMR) greater than 50. The current design calls for an extraction level

- at -2400 ft elevation for Blocks N<sub>1</sub> through N<sub>7</sub> and N<sub>9</sub>;
- at -2450 ft for Blocks S<sub>1</sub> and S<sub>2</sub>; and
- at -2100 ft for Block N<sub>8</sub>.

Mining blocks are approximately 855 ft wide with a maximum underground production rate of 50,000 tons per day in each block. A total of 150,000 tons per day is obtained from multiple mining blocks. Load Haul Dump (LHD) units working on the extraction level direct tip into jaw crushers with conveyors transporting the crushed ore to the production shafts.

A conceptual mining block layout is shown in Figure 1.7.4. The extraction levels are at different elevations as shown in the cross-section along A-A' (Figure 1.7.5). A schematic of the mine design is presented in Figure 1.7.6.

**Figure 1.7.4 Conceptual Underground Mining Block Layout – Plan View**



**Figure 1.7.5 Section A-A' through the Conceptual Mine Block Layout**

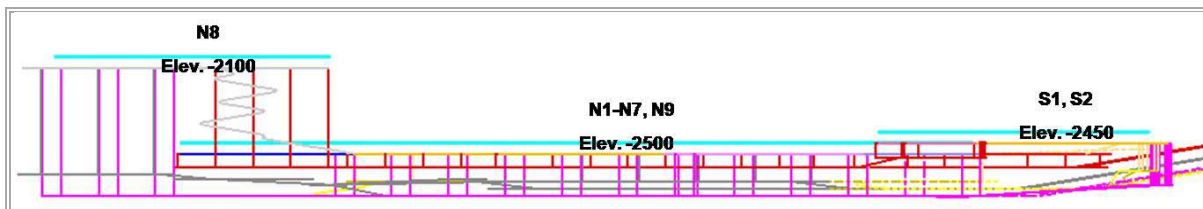
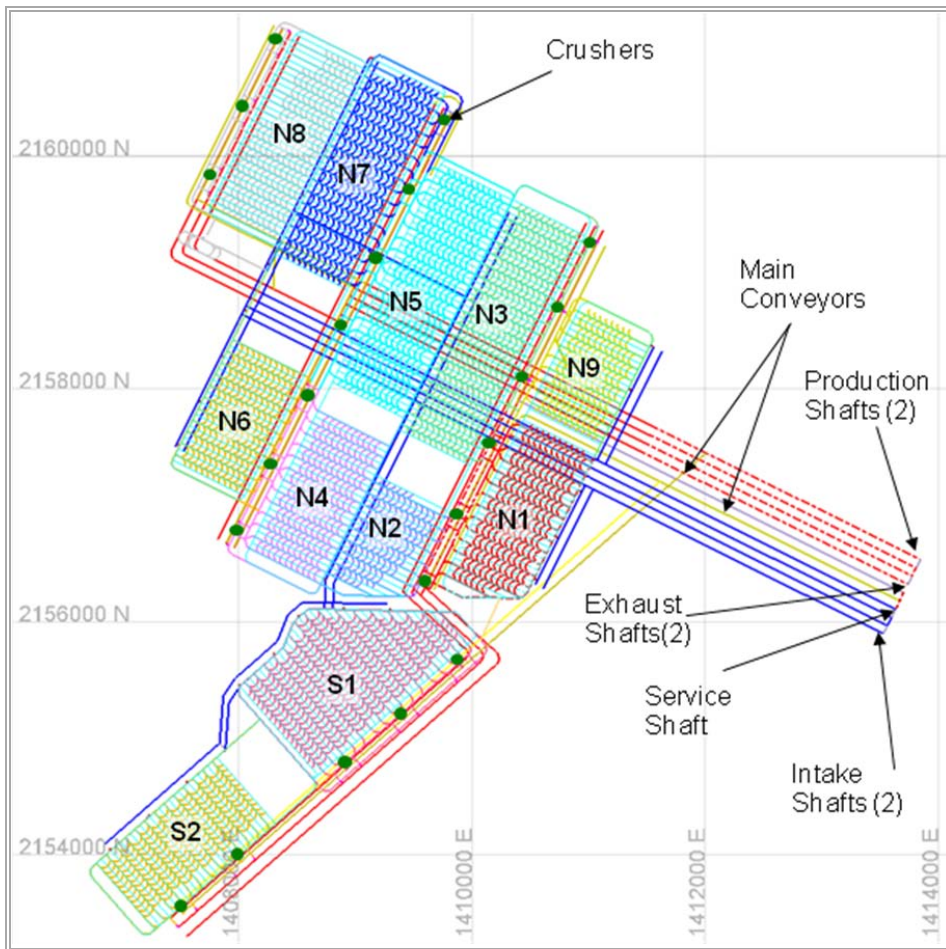


Figure 1.7.6 Underground Mine Design Schematic – Plan View



#### MINEABLE RESOURCE SUMMARY

Production scheduling has been performed for each of the mining blocks. The production schedules include grades and tons by year for NSR, copper, gold, molybdenum, energy (for comminution evaluations), and density.

NSR values have been calculated into the mining blocks. Using an NSR cut-off value of \$20 per ton, the highest value mining blocks have been selected based on the geotechnical criteria to support 50,000 tons per day per block.

#### PRE-PRODUCTION

Based on the underground mine design and associated infrastructure requirements, a conceptual pre-production schedule has been developed. The total estimated duration to complete the development and construction requirements to initiate production is approximately five years. The following lists the key components of the underground design that are scheduled to be complete during the pre-production period:



- service shaft sinking and commissioning;
- Ventilation shaft sinking and commissioning;
- Crusher No. 1 excavation and commissioning;
- Main Conveyor No. 1 decline and installation;
- N<sub>1</sub> undercut level access ramps;
- Exhaust drifts and raises from N<sub>1</sub>;
- Ventilation drifts between the footprint and the shafts;
- Main pumping system with 15,000 USgpm pumping capacity;
- Maintenance shop;
- Main powder and cap magazines; and
- Underground offices and warehousing.

## PRODUCTION

A total of 1,459 million tons of ore will be mined over a 35-year underground mine life. Ramp up to full production is approximately eight years, at which time the annual production rate will be 54 million tons per year (150,000 tons per day at 360 days per year). Based on this schedule, full production is sustained for 16 years, followed by an 11 year tail-off period as final drawpoints close.

## PERSONNEL

Estimates for both contractor and owner personnel required to develop, construct, operate, and support the Pebble East block cave mine have been made.

During the pre-production development period, the peak year for contractor personnel working onsite is Year -1, with an estimated 199 workers onsite.

The peak year for owner's personnel requirements is in Year 6. During this year, the estimated working personnel is 555, and payroll personnel is 808 (totals include operating directs, indirects, and sustaining capital development personnel). Based on the production schedule and the estimated working personnel requirements, the average life-of-mine productivity is approximately 144 tons per manshift.

## COST ESTIMATES

### *Capital*

Capital costs for the development and operation of the proposed Pebble East block cave mine are defined as pre-production capital (i.e. prior to start of production) and sustaining capital (i.e. capitalized expenditures over the life-of-mine). All costs are represented as current US dollars. A summary of the life-of-mine capital costs are presented in Table 1.7.6.

**Table 1.7.6 Underground Mining Capital Cost Summary (US\$ millions)**

Capital Development	Pre-Production	Sustaining	Total
Contractor Mob/Demob/Setup/Teardown	5.71	4.69	10.39
Lateral Development	100.55	212.64	313.18
Shaft Sinking and Construction	139.15	227.96	367.11
Raise and Borehole Development	1.00	22.10	23.10
Development Material Handling	11.81	7.55	19.36
Surface Facilities Construction	110.78	5.41	116.19
Underground Construction and Installation	23.21	75.09	98.30
Contractor Indirects and Margins	230.85	136.33	367.18
Mobile Equipment	89.36	1,406.17	1,495.53
Fixed Equipment	256.27	350.28	606.55
EPCM and Owner's Costs	86.19	51.17	137.37
Electrical Power	58.91	–	58.91
Contingency @ 25%	272.64	624.84	897.48
<b>Total</b>	<b>1,386.43</b>	<b>3,124.23</b>	<b>4,510.65</b>

### *Operating*

Operating costs include direct and indirect costs associated with ore production and sustaining development. Operating cost items include the following elements:

- Extraction level development and construction;
- Undercut level development;
- Repairs;
- Direct production:
  - Undercutting; and
  - Drawbelling;
- Rock handling:
  - LHD operations;
  - Secondary breaking;
  - Crushing;
  - Conveying; and
  - Hoisting;
- Power; and
- Indirect costs:
  - Staff labour;
  - Hourly labour;
  - Services; and
  - Support equipment operation.

Over the production period, approximately 1,459 million tons will be extracted from the underground development. Life-of-mine operating expenditures are estimated at \$7.43 billion, resulting in an average life-of-mine operating cost of \$5.09/ton with a full-production operating cost of \$4.88/ton. A summary of the operating costs for a typical full production year is presented in Table 1.7.7.

**Table 1.7.7 Underground Mining Unit Operating Cost Summary for Typical Full Production Year**

Description	Cost (\$/t)
Lateral Development (Undercut and Extraction Levels)	0.40
Production Directs	0.34
Construction	0.19
Material Handling	1.17
Maintenance and Repairs	0.07
Support Equipment Operating (Excludes Labour)	0.18
Mine Services (Excludes Labour)	0.23
Indirect Labour – Staff	0.38
Indirect Labour – Hourly	1.02
Electrical Power @ \$0.066/kWh	0.92
<b>Total Full Production Operating Cost</b>	<b>4.88</b>

#### LIFE-OF-MINE EXPENDITURE SCHEDULE

The life-of-mine capital and operating cost expenditure for underground mining is estimated at \$11.94 billion over a 35-year period. Based on the 1,459 million tons scheduled to be produced from the underground, the total capital and operating cost per ton is \$8.18 and the sustaining capital and operating cost is \$7.23/ton.

## 1.8 PROCESS

### 1.8.1 INTRODUCTION

Extensive comminution and metallurgical test programs have been conducted on metallurgical samples from Pebble West and Pebble East. These programs include variability testing, vendor testwork and mineralogical examinations to support process design. Computer modelling and benchmarking visits to large-scale copper porphyry operations have also been conducted to assist in the selection of the optimum flowsheet configuration. The resulting flowsheet and process design is a conventional circuit, similar to many existing designs for large-scale copper porphyry operations around the world.

### 1.8.2 COMMINUTION

Simulations have been conducted for several combinations of size and power for semi-autogenous grinding (SAG) and ball mills. Considering the greater proportion of harder Pebble West ore in the 25-year IDC Case, the average power requirement per ton of ore will be marginally higher than for the 45-year Reference Case and the 78-year Resource Case. These subsequent phases of mining will process increasing amounts of softer Pebble East ore.

The 75<sup>th</sup> percentile of hardness for a 200,000 ton per day processing plant has been selected as the design criteria for downstream plant capacity. A target of 80% passing 200 µm, determined from the grind recovery work, has been selected as the appropriate feed size for the flotation circuit. The resulting comminution design features two 40 ft x 25 ft @ 29 MW SAG mills and four 26 ft x 40 ft @ 16.4 MW ball mills in SABC-A configuration, in which the crushed pebbles are recycled to the SAG mill.

The variation in ore grindability manifests as a considerable variation in grinding capacity. The mine production forecast accounts for this range of grindability by utilizing the comminution energy consumption as a controlling variable. Accordingly, the annual production tonnage fluctuates over the mine life in each case in response to the ore hardness. The annual throughput in the 25-year IDC Case averages 219,000 tons per day and averages 229,000 tons per day in the 45-year Reference and 78-year Resource Cases.

Additional simulations have been undertaken for different proposed grinding circuits, in what has been designated an SABC-B configuration. In the SABC-B configuration, the ball mill processes the crushed material. The SABC-B configuration achieved an average improvement in capacity of 6.6% over SABC-A.

### 1.8.3 METALLURGICAL TESTWORK

Optimization batch rougher and cleaner flotation testwork was undertaken in 2009 to determine the effects of primary grind size, pH, reagent dosage, and retention time on the metallurgical performance of four global composites. In summary, optimum rougher flotation conditions for the four composites have been established at:

- rougher pH of 8.5 (natural pH of composite samples ranged between 5.7 and 7.1);
- rougher laboratory retention time of 12 minutes; and,
- 27.5 g/t potassium ethyl xanthate (PEX) and 12.5 g/t fuel oil addition, split in 65:35 between the primary grind and the second roughing stage.

Variability testwork using a batch flow sheet has been undertaken on 82 samples selected from the Pebble East (10 samples) and Pebble West (72 samples) zones between July 2009 and March 2010. Variability samples (53 hypogene and 29 supergene) have been selected to represent a broad range of head grades, pyrite content, copper speciation, clay content, alteration and rock types. The average batch cleaner bulk copper-molybdenum concentrate grade for the hypogene samples is 28.8% Cu, 18.7 g/t Au and 1.12% Mo at 80.5% Cu, 46.8 % Au and 61.0% Mo recoveries. The average concentrate grade is similar for the supergene samples at 28.9% Cu, 17.0 g/t Au and 0.90% Mo, but average

recoveries were lower for copper and gold at 65.9% and 37.2% Au, and similar for molybdenum at 60.0%.

Locked cycle tests completed on 38 (20 hypogene and 18 supergene) of 72 variability composites from the Pebble West zone show recovery increases of 7% for copper and 11% for both gold and molybdenum to the bulk copper-molybdenum cleaner concentrate.

Based on results from the copper molybdenum separation testwork, copper molybdenum separation efficiencies have been updated in the process design to assume stage recoveries of: for supergene, 99.4% Cu and 98.9% Au to the copper-gold concentrate, and 98.4% Mo to the molybdenum concentrate; and for hypogene, 99.8% Cu and 98.9% Au to the copper-gold concentrate, and 92.8% Mo to the molybdenum concentrate.

Tails thickening testwork has been performed on three rougher tailings samples with a  $P_{80}$  size of approximately 200  $\mu\text{m}$ , produced from the supergene, illite pyrite and carbonate materials from the bulk flotation products. All samples achieved target underflow densities with varying solids loading rates, dosage rates and overflow clarities.

Results of the gold recovery work show recoveries to the pyrite concentrate of between 47% and 97% (averaging 82%), with gold grades ranging between 1.1 g/t and 6.4 g/t (averaging 2.6 g/t). For tests conducted at 25  $\mu\text{m}$ , average gold extraction is 55%, compared to 80% at 10  $\mu\text{m}$ .

Using the results of the locked cycle variability testwork undertaken on the Pebble West samples, recovery equations have been developed for copper, gold and molybdenum using the statistical package within Microsoft Excel. For each metal unit, a sensitivity analysis has been conducted evaluating various combinations of key variables thought to influence recovery – such as head grade, feed pyrite content, feed soluble copper and rock type. Recovery equations have been chosen based on the combination of variables that provided the highest "R" squared value. Maximum achievable recoveries are included for each equation, as estimated based on the interpretation of the testwork results.

#### 1.8.4 GEOMETALLURGY

A geometallurgical study of the Pebble deposit has been undertaken over the past two and a half years. The principal objective of this study is to divide mineralization into domains that manifest internally similar mineralogy and copper and gold department. This work has delineated five main geometallurgical material types within the mineralized envelope at Pebble. This analysis has been accommodated in plant design.

#### 1.8.5 PROCESS RECOVERIES

Metallurgical recoveries have been derived to reflect the testwork results and the geometallurgical domains. These data have been input the resource model and have been reported in the mine production forecast, ultimately forming the basis for the financial model input. Table 1.8.1 shows the average life-of-mine recoveries for copper, gold and molybdenum for each of the three cases.

**Table 1.8.1 Life-of-Mine Process Recoveries**

Item	Unit	IDC Case	Reference Case	Resource Case
Copper Recovery	%	86.6	87.9	88.4
Gold Recovery	%	71.5	71.3	71.2
Molybdenum Recovery	%	84.8	87.9	89.4

### 1.8.6 PROCESS DESIGN

The development cases presented in this Preliminary Assessment site the Pebble process plant on the southwest flanks of three knolls lying north of the deposit. This site has been selected following a series of studies which evaluated geotechnical and environmental considerations, proximity to the open pit and tailings facilities, and site geometry. In addition to the process plant, the site also contains a coarse ore storage area (COS), two 330-ft diameter thickeners and a tailings pump house at the lower end of the process plant, ancillary facilities and the power generation plant.

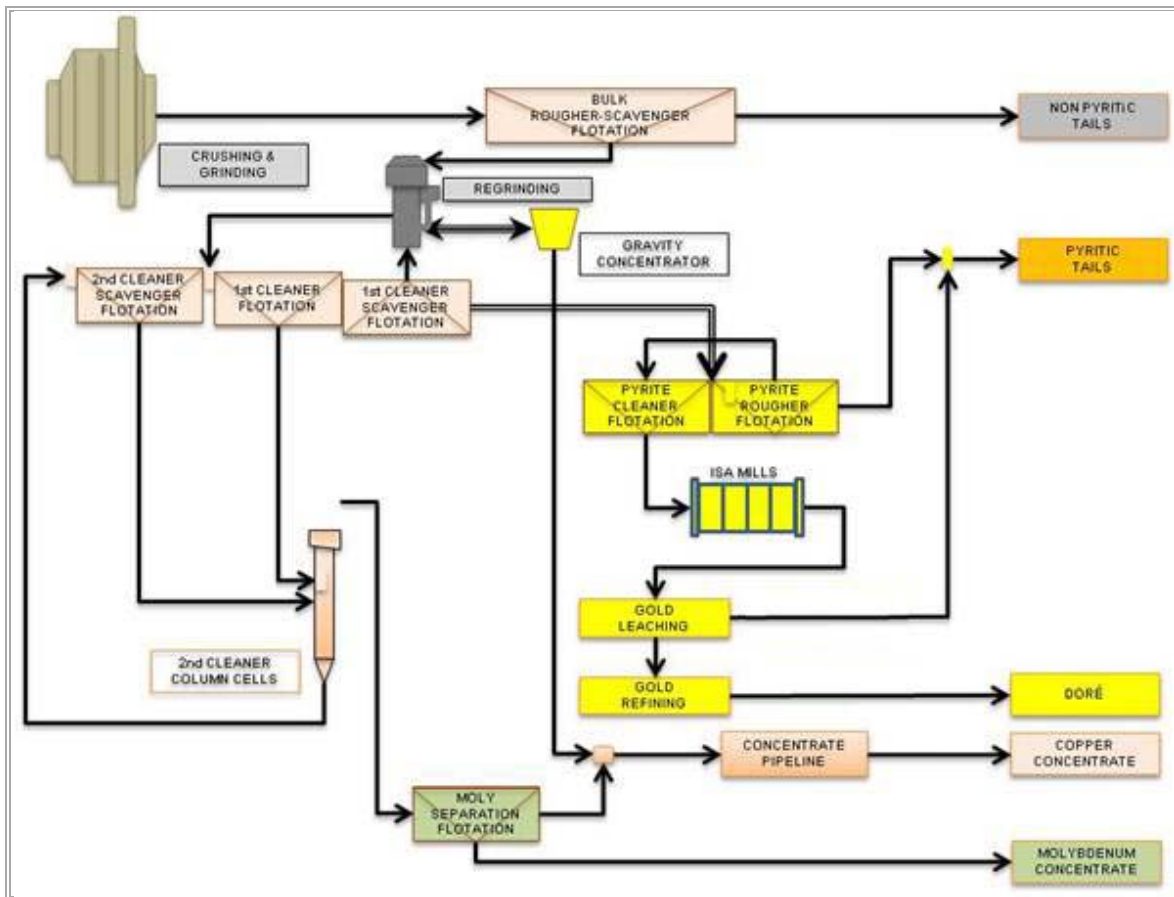
The design basis for the process facility is a concentrator with a nominal throughput capacity of 200,000 tons per day. Process design criteria for the facilities are based on testwork conducted from 2004 through 2010, supplemented by benchmarking studies. A simplified schematic of the flowsheet is shown in Figure 1.8.1.

Grinding design has been driven by the characteristics of the ore from the open pit, which reflects the feed material to the concentrator in the early years of mine operations. In addition to tonnage, the concentration and filtration circuits take into consideration the elevation of tonnage through the incorporation of softer material as the open pit dives deeper into the deposit.

The process is based on conventional grind-crush-float technology, using proven plant equipment of the largest sizes that have been industrially installed.

Run-of-mine (ROM) ore from the open pit will be crushed and conveyed to the concentrator. The ore feed will be ground to liberate the mineral values from the host rock, and then separated by industry-standard flotation processes. A bulk copper/molybdenum sulphide concentrate will pass through the molybdenum separation circuit to produce a molybdenum sulphide concentrate, which will be bagged and trucked to port facilities on Cook Inlet. The molybdenum separation generates a copper concentrate (containing most of the recovered gold) that will be pumped through a pipeline to the port site. The pyrite concentrate will report to a secondary gold recovery circuit where gold doré and bagged carbon-bearing fines will be produced and shipped off-site. Recovered gravity gold will be sent to the copper concentrate.

Figure 1.8.1 Simplified Process Flowsheet



Tailings generated in the milling process will be separated into two streams: tailings from the rougher flotation circuit (bulk tailings); and tailings from the secondary cleaner circuit (cleaner scavenger tailings and gold plant pyrite tails, referred to collectively as cleaner scavenger tailings). The two tailings streams will be managed separately. Bulk tailings solids are benign, whereas the pyrite-rich cleaner scavenger tailings could generate acidic conditions if allowed to oxidize. To ensure that oxidation of the cleaner scavenger tailings does not occur, tailings management practices will include encapsulation of the cleaner scavenger tailings within the accreting bulk tailings deposit and sub-aqueous storage within the tailings pond.

### 1.8.7 TAILINGS

Tailings management concepts for the 25-year IDC Case presented in this Preliminary Assessment provide a well-researched engineered solution for permanent, stable storage of approximately 2.0 billion tons of tailings.

More than thirty tailings storage facility (TSF) options have been studied, assessing environmental, geographic, tenure, seismic and cost considerations. While engineering for a TSF with sufficient capacity to receive tailings generated by mine life extensions beyond 25 years have not been advanced,

topographical and land status conditions in the project area present a number of nearby siting opportunities.

As noted, phases of development beyond 25 years will require separate permitting and development decisions to be made in the future, based on prevailing conditions at the time and the accumulated experience gained from developing and operating the initial phase of the Pebble Project.

The option selected for the 25-year IDC Case is the Site G TSF, located approximately three miles west of the open pit (shown in site layout in Figure 1.1.3). The TSF impoundment will be created by three embankments. The north embankment will be constructed initially to a height of approximately 200 ft. This embankment will be raised each year, while the south and east embankments will be built later in the mine life as the impoundment fills. The ultimate height of the north embankment will be approximately 685 ft, while ultimate heights for the south and east embankments will be approximately 450 ft and 100 ft respectively.

Recognizing the seismic characteristics of Alaska, particular attention has been paid to understanding seismic risk factors in the TSF design. The embankment design parameters conform to Alaska Dam Safety regulations, under which they would be classified as Class II structures. Extensive research has been conducted into historical seismic events, in Alaska generally and in southwest Alaska in particular, to support an assessment of the probability and magnitude of seismic events that might affect Pebble.

Analysis of public domain literature was undertaken to determine the location of likely sources for seismic events near Pebble, with the most likely candidate identified as the Lake Clark Fault. The location of this fault has been identified as part of a geophysical survey of the region. Using these data, as well as public domain information, the energy that might be released if a major earthquake were to occur along the Lake Clark Fault has been determined.

The parameters used in this analysis are extremely conservative. For instance, while there is no evidence of movement along the Lake Clark Fault since the last glaciers receded some 10,000 years ago, TSF seismic design criteria assume that it is an active fault. Further, sections of the Lake Clark Fault nearest the Pebble Project are actually splays of the main fault and thus unlikely to release the same energy as if the entire fault was to move. Nonetheless, TSF seismic design criteria have conservatively assumed that the Lake Clark Fault is both active and capable of a seismic event equivalent to slippage along the entire fault.

Design features of the TSF intended to control seepage from the impoundment also received special consideration. Site conditions have been thoroughly investigated over a number of field campaigns, and will continue to be studied through the final design phases of the Pebble Project. This data has contributed to a superior understanding of geological conditions and water flow, both surface and sub-surface, from the impoundment valley. As a result, the engineering team has incorporated the following seepage control features into the TSF design:

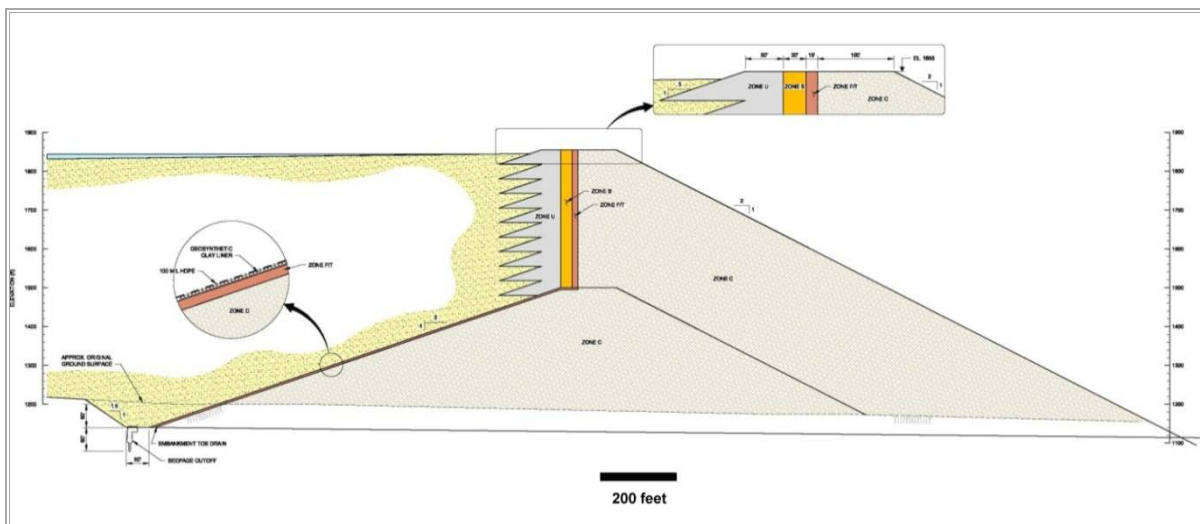
- At the upstream toe of the embankment, overburden and broken rock at the top of the bedrock will be excavated to solid bedrock, and a grout curtain injected below that point to minimize seepage below the embankment.



- A geotextile membrane will be laid up the face of the embankment, further reducing seepage through the embankment.
- This geotextile membrane will be keyed into a concrete plinth constructed above the grout curtain, thus ensuring interconnection of the primary seepage control mechanisms.
- A seepage collection system will be installed downstream of these design elements to capture any seepage that does migrate through them. Seepage collected in this system will be pumped to either the tailings impoundment or the process plant.
- Wells further downstream will monitor the groundwater quality and can be converted into recovery wells, if necessary.

A typical cross-section through the northern TSF embankment is shown in Figure 1.8.2. Embankments will be constructed in zones, with filter, transition and core material comprising those zones associated with seepage control. Embankments will be constructed from benign waste rock mined from the open pit during operations.

**Figure 1.8.2 Typical North Embankment Section**



Two tailings streams will be produced from the process. Bulk rougher tailings comprise approximately 85% of the process plant feed and will be benign. These tailings will be pumped from the process plant to pipelines lying along the crest of the embankments. They will discharge via a series of spigots onto beaches along the faces of the embankments. These sandy beaches will channel tailings water away from the embankments, resulting in a relatively shallow pond at some distance from the embankment, further enhancing seepage reduction measures.

The second stream of tailings consists of the pyrite-rich flow from the cleaner scavenger tailings. These tailings will be pumped via a separate pipeline and discharged sub-aqueously into the centre of the TSF pond. Sub-aqueous disposal will eliminate the potential for these tailings to react to create acidic conditions.

The discharge of surplus water from the Pebble Project will be limited by regulation and permit, and will be strictly controlled. Thus, it is necessary to recycle water from the TSF pond. To accomplish this, barge-mounted pumps will recover the water from the pond and return it to the process plant or water treatment plant for discharge.

### 1.8.8 WASTE ROCK MANAGEMENT

Approximately 2.4 billion tons of non-acid generating waste rock (NAG) and 0.6 billion tons of potentially acid generating waste rock (PAG) will be mined during the 25-year IDC Case.

This rock will be placed into two pit rim waste dumps – one wrapping around the east end of the open pit and the second along the southwest and south sides of the open pit. Expansion of these waste dumps will be staged to reduce runoff requiring treatment.

NAG waste rock will be stored in the dumps to the south and east of the open pit mine workings. Because of its low potential for acid generation, this waste rock is considered to be suitable for construction of tailings embankments and other permanent facilities requiring rockfill.

The PAG waste dump will lie at the western side of the pit. This waste rock contains low-grade copper mineralization that will be processed through the mill at the end of mining operations, with attendant tailings being discharged into the open pit.

Waste dumps are shown in Figure 1.1.3.

Monitoring and recovery wells, as well as seepage cut-off walls extended and keyed into low-permeability zones, will be constructed downstream of the waste dumps for seepage management. Zoned embankments will be constructed above the seepage cut-off walls to provide containment of waste dump surface runoff flows from storm events that exceed the capacity of the runoff collection ponds, and the pumping and pipeworks systems. Runoff from the waste dumps will be pumped to the process water pond.

### 1.8.9 CLOSURE

The Site G TSF presented in this Preliminary Assessment will require monitoring to ensure long-term physical and geochemical stability. A comprehensive closure plan has been prepared to ensure protection of the downstream environment, including re-vegetation of embankment faces and exposed tailings surfaces, incorporating wetlands and ponds on the reclaimed tailings surface, and construction of an overflow system.

Waste rock dumps will be constructed to a geometry that minimizes closure liability, including siting these facilities within the pit groundwater cone of depression and ensuring suitability for re-vegetation and water management. PAG waste rock will be fed through the process plant for metal recovery at the end of mine operations, with attendant tailings discharged into the open pit. Once PAG waste rock has been removed, the base will either be removed for in-pit disposal or covered with soil and re-vegetated. Remaining NAG waste rock piles will be covered with soil and re-vegetated.

### 1.8.10 WATER MANAGEMENT

The water management plan associated with the three successive development cases presented in this Preliminary Assessment has three distinct phases – construction, operations, and closure.

During construction, structures will divert water away from working areas and measures will be taken to control sediment. Once the TSF starter embankment construction is complete, site water will be diverted into this facility to ensure adequate make-up water for process plant start-up. At this time, advanced open pit dewatering will commence. This water will either be treated and discharged or diverted to the TSF, depending on environmental requirements.

Diversion structures will remain in place through the life of the mine. Excess site water will be diverted to the TSF. Surplus water will be treated to meet regulatory requirements before being discharged. The timing, location and quantity of this discharge will be managed to optimize downstream flow conditions for fish and aquatic habitat.

Water treatment capacity will increase over time as the amount of water to be treated increases. Treatment procedures will also change as water chemistry changes.

At closure, the tailings storage facility will be reclaimed. During this period, all water will be diverted to the open pit to allow it to fill to a specified level to ensure ongoing groundwater flow into the open pit. Thereafter, water levels will be maintained by treating inflow and discharging it as during operations.

## 1.9 INFRASTRUCTURE

---

Pebble infrastructure will include those facilities required at the mine site to support operations – such as maintenance facilities, offices, utilities and worker accommodation – as well as: a tidewater port for concentrate off-loading and trans-shipment of operating supplies; an access road to connect the mine site with the port site and the existing airport at Iliamna; pipelines for concentrate, diesel fuel and natural gas transport; and, an electrical power generation facility.

While these infrastructure components add complexity to the project, models for such development do exist in Alaska – including Teck's Red Dog mine. In addition, concentrate transport at many copper mines currently operating, under construction or contemplated in South America or Asia utilize concentrate pipelines, which have become a well understood and economically viable alternative to truck haulage.

Pebble does have a number of key advantages. One, while there are few existing roads in the project area, much of the road route follows rolling glaciated terrain, which will minimize construction costs for these sections. The existing state-run airport at Iliamna is a high quality facility, which would cost tens of millions of dollars to replicate. The deposit is located at approximately 1,000 ft amsl, which eliminates many of the issues associated with high altitude development. The selected port site has deep water immediately offshore, enabling loadout pier construction without the need for a long jetty or lightering. Further, it is ice-free for 11 months of the year, obviating the need for long storage periods for concentrate and supplies.

Important design considerations in developing the mine site layout include (Figure 1.1.3):

- Minimize the difference in elevation and the horizontal distances between the open pit, mill site, crusher and tailings pond, with the intent of minimizing capital and operating costs of truck haul, conveyor haul and pipelines between these sites.
- Avoid and minimize environmental impact on three local stream systems – the North and South Fork Koktuli River and Upper Talarik Creek.
- Site run-off and drainage from the mill site is to be contained by perimeter ditches and directed to a sedimentation pond, then to either the TSF or the water treatment plant.

The process plant and associated facilities are located approximately 1,000 ft north of the open pit on level to rolling ground at the edge of a knoll, which marks the north edge of the deposit. Site preparation will consist of levelling the site, with major components (such as the grinding mills) founded on bedrock.

Infrastructure components at the process plant site include:

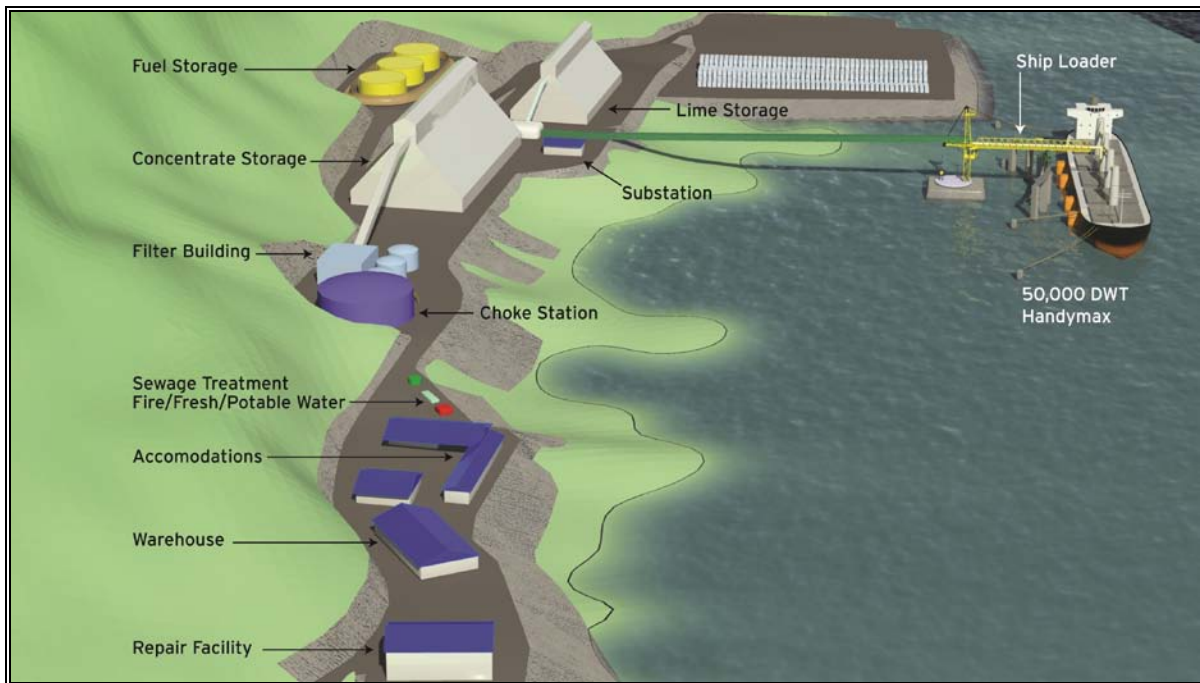
- an electric power generation plant;
- standby electric power generation;
- main substation and power distribution;
- potable and fire water storage and distribution;
- sewage treatment;
- laydown and container storage yard; and
- permanent camp and administration offices.

Mine maintenance and administration facilities will be located at the crusher site, approximately 500 to 1,000 ft north of the open pit on the east side of the knoll upon which the plant site is located.

Topography at Port Site 1 comprises a strip of gently sloping land approximately 300 ft wide along the shoreline, with cliffs/steep slopes rising on the inland side to the west and ocean to the east. The port site layout will be strung out along this bench. Facilities at the port will include a barge dock berth, deep-sea ship dock, container storage and a handling area for 900 containers. Infrastructure components at the port site include a power generation plant, accommodation and maintenance facilities, offices, fuel storage and transfer facilities.

The port layout is shown in Figure 1.9.1.

**Figure 1.9.1 Port Site 1 Layout**



### 1.9.1 POWER GENERATION

The capacity of the mine-site power plant will be 378 MW, built as a 5 x 5 x 3 configuration. It will consist of five aeroderivative gas turbines (215 MW) matched to five supplementary fired once-through steam generators, which supply the energy to three non-reheat-type steam turbines (120 MW). The steam turbines will operate from common steam headers. A sixth single cycle gas turbine (43 MW) will also be installed to meet peak plant capacity requirements at the peak summer design temperature.

Current project planning assumes that the nearby Cook Inlet gasfield will not produce adequate natural gas supply to meet project needs in the near-term. Alaskans are currently evaluating alternatives to replace existing Cook Inlet natural gas supply, which serves the south-central region of the state. Alternatives include several new gas line options from northern Alaska and the North Slope, or the importation of LNG. It is expected that the Pebble Project will utilize the natural gas source ultimately selected by the State of Alaska to supply its power plant by connecting to the existing natural gas distribution system on the Kenai Peninsula. The Pebble Project may also serve as a catalyst and anchor customer for new natural gas production and infrastructure development in the State of Alaska.

The Pebble natural gas supply pipeline will originate from existing lines on the west side of the Kenai Peninsula and will cross Cook Inlet from some point near Anchor Point, where the gas will be compressed. The pipeline traverse across lower Cook Inlet will be approximately 60 miles in an externally coated, heavy-wall pipe to Port Site 1. Here, the line will be tapped to supply port site power requirements. The pipeline will be laid in the transportation corridor between the port site to the mine site.

### 1.9.2 PORT SITE

The Pebble Project will require development at two waterfront locations 60 to 65 miles from the mine site. These are Port Site 1, the permanent product loadout facility on Iniskin Bay; and Williamsport, the proposed site of an initial inbound logistics facility at the head of Iliamna Bay.

The Williamsport facility will be temporary, enhancing the existing capacity of this site to enable initial construction mobilization for site access. It will be reclaimed once the permanent facilities at Port Site 1 are available.

The permanent Post Site 1 facility is designed to accommodate the shipping of 1.1 million tons of concentrate per year in 28 vessels, with a 36-hour berth-to-deberth time. The port will be capable of handling 50 million gallons of fuel and 31 container barges per year, and will have attendant fuel storage and laydown areas.

Port Site 1 is adjacent to deep water and does not require dredging for port access or mooring. Winter access is estimated to be limited during four weeks of the year as a result of ice conditions. Severe seasonal storms with wind and waves that prevent mooring at the dock have been modeled to last up to five days.

Offshore facilities at the port site include a conveyor system mounted on a jetty, feeding a shiploader capable of off-loading 2,000 tons of concentrate per hour, inclusive of hatch changes and trimming. Vessels to Handymax size will moor in approximately 50 to 75 ft of water to mooring dolphins adjacent to the shiploader. The barge dock will enable berthing of 400-ft long barges in approximately 20 ft of water. A yard capable of storing 900 ISO 20-ft containers will be installed immediately onshore of the barge dock.

Concentrate handling facilities at the port site include the concentrate pipeline terminal, concentrate dewatering and concentrate storage. The concentrate pipeline terminal will include a choke station to regulate flow in the pipeline, a concentrate storage tank, filtrate storage tank and pump station to return the filtrate to the mine site.

Concentrate will be dewatered to shippable levels (approximately 7.5% moisture) and conveyed to a storage building with 35 days of capacity. Concentrate will be stacked inside the building, to be reclaimed by wheel loaders feeding a conveyor system, which will transfer to the offshore loadout system.

Other port site facilities include diesel fuel storage and a pumping station to transfer the fuel to the mine site, offices, worker accommodation and maintenance shops. A natural gas-fired 8 MW plant will supply electrical power to the port site.

### 1.9.3 ACCESS ROAD

The proposed mine access road will meet mine development and support needs over the life of project. It will be 86 miles long, two lanes (30 ft) wide and constructed with a gravel surface to provide an all-weather road capable of supporting all anticipated development and operational activities. The road will also provide a transportation link to the existing Iliamna airfield.

Twenty bridges will be constructed over the length of the route, with spans ranging from 40 to 600 ft. The route also includes an 1,880-ft causeway across the upper end of Iliamna Bay and approximately five miles of embankment construction along coastal sections in Iliamna Bay and Iniskin Bay.

The transportation corridor is shown in Figure 1.9.2.

**Figure 1.9.2 Pebble Project Transportation Corridor**



### 1.9.4 PIPELINES

Four pipelines will be constructed between the mine site and the port site, buried either in the access road right of way or under the road prism.

One of these will be an 8-in. diameter steel line to transport copper-gold concentrate from the mine to the port site. The pipeline will be continuously welded in 1,500 to 3,000 ft lengths and lined with an HDPE liner to protect against abrasion and corrosion. The lengths will be joined with flanges.

One pump station at the mine site, equipped with two positive displacement diaphragm pumps, will be adequate for the line. A choke station will be required at the port terminal to prevent slack flow in higher sections of the line near the port.

The pipeline will be equipped with leak detection and cathodic protection. It will be either drilled under stream crossings or carried on bridge structures. In the latter instances, it will be encased in a second pipeline to provide secondary containment.

The filtrate produced by concentrate dewatering must be returned to the mine site through a second 7-in. diameter steel line. This line will be of similar construction to the concentrate pipeline and will be fed from a pump station at the port site.

Natural gas and diesel fuel will also be transported from the port to the mine site via pipelines.

## 1.10 SUSTAINABILITY

---

### 1.10.1 PROJECT PLANNING

Since 2004, comprehensive environmental and socioeconomic baseline studies have been undertaken at the Pebble Project, in addition to ongoing stakeholder engagement and community outreach. The goal of these initiatives is to facilitate the development of an environmentally sound, socially responsible and permittable project that reflects the priorities and concerns of local communities, while generating meaningful benefits for local people.

Planning for the Pebble Project reflects the rigorous mine permitting process in Alaska, the environmental and social sensitivities of the project area, and the business realities of working in the state. This approach has a number of key dimensions, including:

- ensuring that project design, technical studies and other initiatives are based on a comprehensive understanding of state and federal permitting laws, regulations and procedures;
- undertaking thorough and robust scientific research to characterize the project setting, and provide effective environmental and social input to project design;
- ensuring that project design and decision making are driven by environmental considerations to ensure the project meets corporate commitments to responsible mineral development, and is ready for successful permitting;
- early and ongoing technical engagement with state and federal agencies that have a role in the permitting process;
- effective and ongoing stakeholder outreach and engagement; and
- comprehensive and ongoing assessment of alternatives to ensure that the project design is optimized from a technical, financial, environmental and social perspective.

### 1.10.2 STATE AND FEDERAL PERMITTING

The Pebble Project must satisfy permitting requirements at the federal, state, and local (borough) level. Though these permitting requirements are extensive, they are also stable, objective and science-based. Rigorous permitting requirements are an asset to projects like Pebble that are designed to meet international best practice standards of design and performance.

Permitting for water withdrawal, fish passage, wetlands and cultural resources has been ongoing throughout the exploration phase at Pebble. Permitting for construction and mine operations is



expected to take some three years to complete and will involve 10 or more regulatory agencies, approximately 65 categories of permits and significant ongoing opportunities for public involvement. A Pebble Mine Permitting Plan has been prepared that provides a list of required permits and environmental plans, and the information necessary to prepare applications and support documents.

Project permitting will be initiated when the Pebble Partnership completes a 'Project Description' and an 'Environmental Baseline Document'. These documents will provide the basis for an Environmental Impact Statement (EIS) to be prepared under the federal National Environmental Policy Act (NEPA). The EIS will be prepared by a third-party contractor under the direction of a lead federal agency. The Pebble EIS will be the focal point for project permitting. It will determine whether sufficient evaluation of the project's environmental effects and development alternatives has been undertaken, and provide the basis for federal, state and local government agencies to make individual permitting decisions.

To satisfy permitting requirements under NEPA and other regulatory statutes, the Pebble Partnership must provide:

- a comprehensive project design and operating plan for mine-site and infrastructure facilities;
- documentation of development alternatives investigated;
- mitigation and compensation strategies, and identification of residual effects; and
- environmental monitoring, reclamation and closure plans.

Associated with permitting are regulatory requirements to provide compensatory mitigation for any residual impacts to wetlands, fish and wildlife. These regulations require the Pebble Project to make reasonable efforts to avoid or minimize impacts before considering mitigation projects or financial compensation. The avoidance and minimization of residual environmental impacts has been a key focus of environmental study programs at Pebble.

### **1.10.3 KEY ENVIRONMENTAL ISSUES AND DESIGN DRIVERS**

The key environmental and social issues associated with development of the Pebble Project have been identified, and are reflected in the Pebble Partnership's baseline data collection program, environmental and social analysis and input to project design, and stakeholder consultation.

The key environmental drivers of the Pebble Project are:

- water – quantity and quality of surface and groundwater;
- wetlands – especially those designated as jurisdictional and thus subject to Section 404 permitting;
- aquatic habitats – especially for salmon and trout;
- air quality; and
- marine environment – especially protected species and consequences for construction and operations planning.

In addition, the Pebble Project is being planned to accommodate the social sensitivities of establishing a large industrial facility in an isolated, sparsely populated region. The project is being planned to maximize local benefits – such as employment, infrastructure development and new business opportunities – while minimizing potential disruptions to traditional lifestyles and avoiding adverse effects on existing resource-based industries.

Before a decision is made to initiate permitting, the Pebble Partnership will undertake a comprehensive suite of environmental and social impact analyses, and an Environmental and Social Impact Assessment. These will provide a rigorous, science-based analysis to clearly demonstrate that the project will meet permitting requirements in Alaska, as well as international best practice for project development.

It should be noted that no decision has been taken by the Pebble Partnership to seek permits for the project as described in this Preliminary Assessment. The project description that the Pebble Partnership ultimately elects to submit for permitting under NEPA may vary in a number of ways.

#### 1.10.4 BASELINE STUDIES

Comprehensive environmental and socioeconomic baseline studies have been undertaken in the Pebble Project area since 2004. These studies have cost more than \$150 million to date, and resulted in an environmental and socioeconomic database whose comprehensiveness and depth is unprecedented in Alaska. Baseline studies encompass the Pebble deposit area, the transportation corridor to Cook Inlet, the marine environment in the area of the port sites, as well as the broader project region as shown in

Figure 1.10.1. The studies have been designed to:

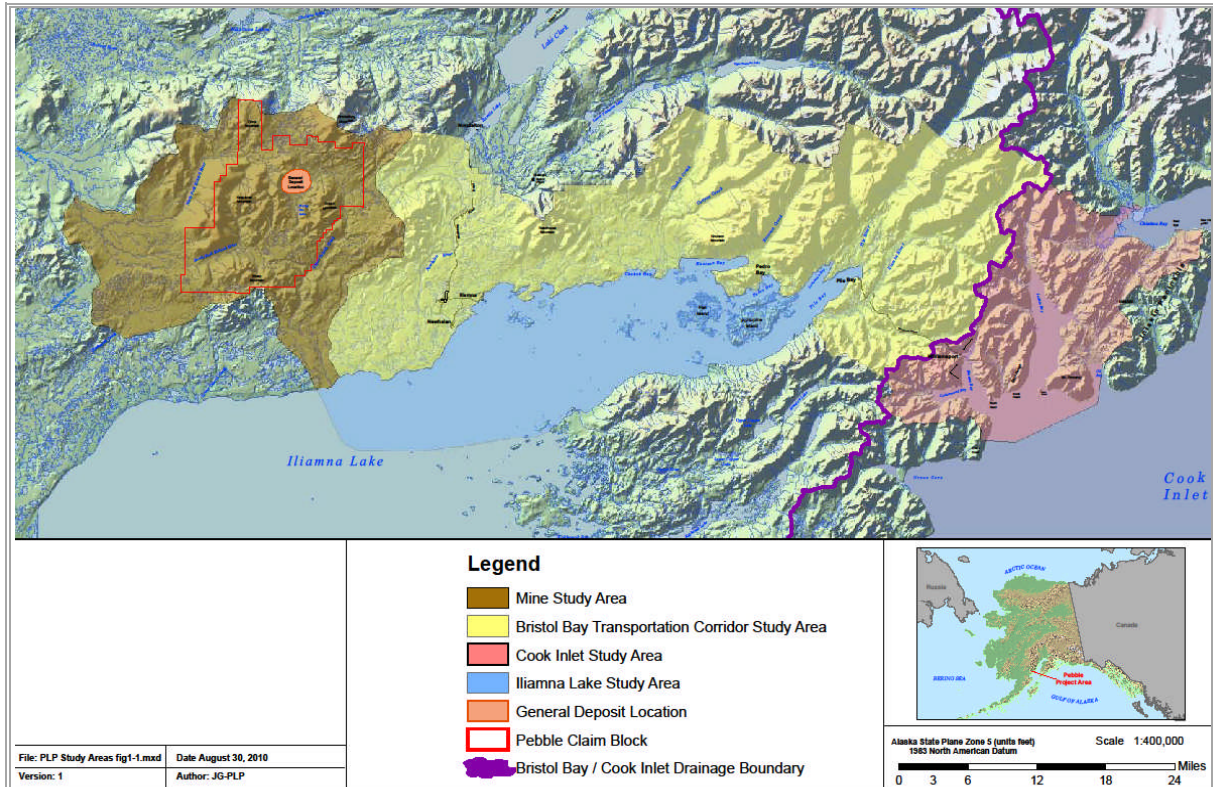
- fully characterize the existing biophysical and socioeconomic environment;
- support environmental analyses required for effective input into project design;
- provide a strong foundation for internal environmental and social impact assessment to support corporate decision-making; and
- provide the information required for stakeholder consultation and mine permitting in Alaska.

Baseline study programs include:

- surface water;
- water quality;
- groundwater;
- geochemistry;
- snow surveys;
- fish and aquatic resources;
- noise;
- Iliamna Lake;
- marine;
- wildlife;
- air quality;
- cultural resources;
- subsistence;
- land use;

- wetlands;
- trace elements;
- flow habitat;
- recreation;
- socioeconomics; and
- visual aesthetics.

**Figure 1.10.1 General Pebble Project Study Areas**



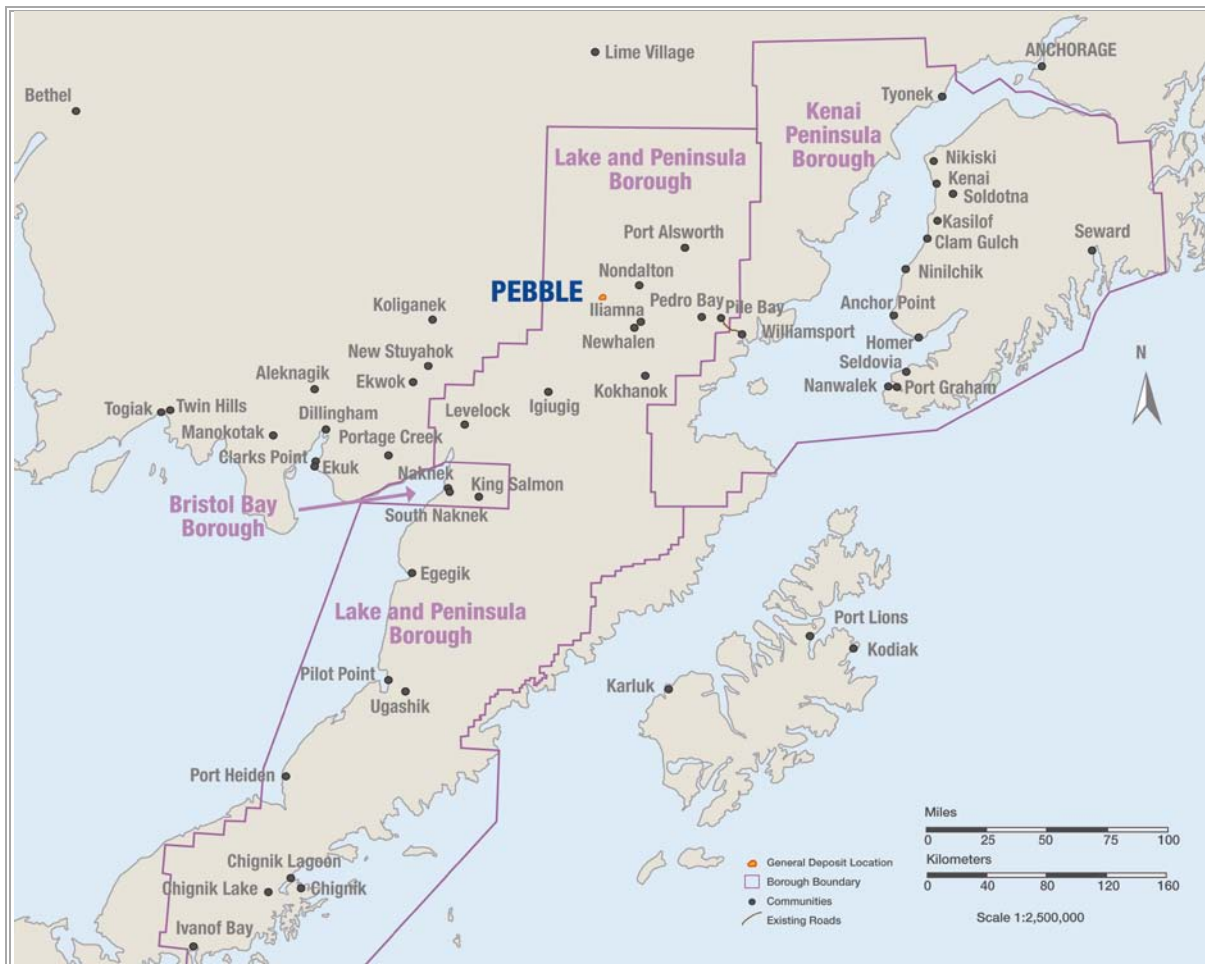
**1.10.5 SOCIO-POLITICAL ENVIRONMENT**

The Bristol Bay region of southwest Alaska presents a multifaceted and geographically variable stakeholder landscape – including borough and city governments, Alaska Native tribes, corporations and institutions, communities, landowners and special interests.

The Pebble Project is located within the 23,782 mi<sup>2</sup> (61,595 km<sup>2</sup>) Lake and Peninsula Borough, as shown in Figure 1.10.2. An estimated 1,485 people reside in 17 communities within the sparsely populated borough.

The 505 mi<sup>2</sup> (1,308 km<sup>2</sup>) Bristol Bay Borough is the only other organized borough in the Bristol Bay region of southwest Alaska. An estimated 881 people reside within this borough’s three communities. A significant portion of the Bristol Bay region of southwest Alaska is not contained within an organized borough. The Dillingham Census Area comprises 11 different communities.

Figure 1.10.2 Boroughs and Settlements of Southwest Alaska



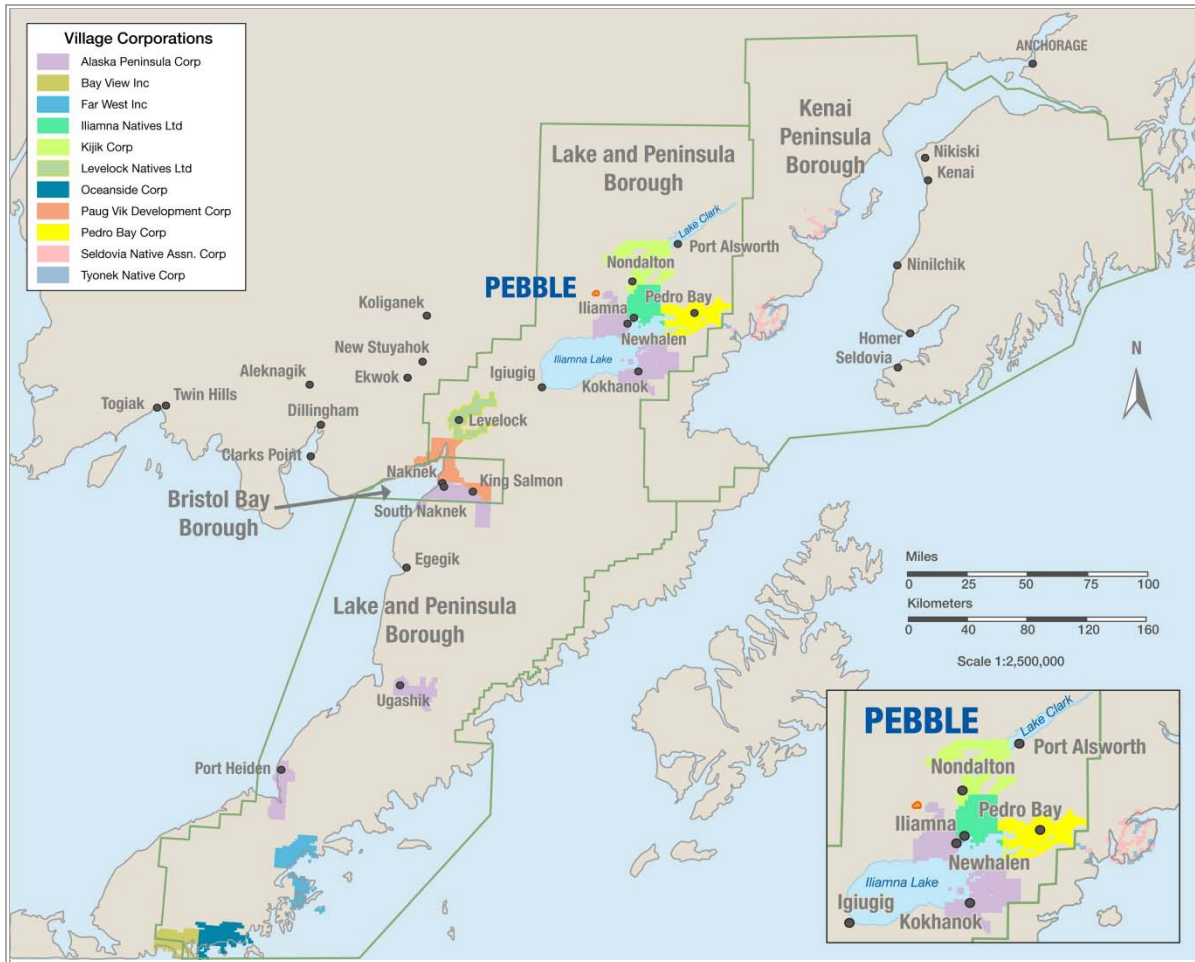
The 15,700 mi<sup>2</sup> (40,633 km<sup>2</sup>) Kenai Peninsula Borough spans both the east and west sides of Cook Inlet, including areas proposed for Pebble Project-related transportation and power infrastructure development.

There are 31 tribal entities within the Bristol Bay region of southwest Alaska, as recognized by the U.S. Bureau of Indian Affairs. Each is represented by a tribal government, alternately known as a tribal council, traditional council or village council.

The Alaska Native Claims Settlement Act (ANCSA) of 1971 created Alaska Native Regional Corporations and Alaska Native Village Corporations. There are a total of two Alaska Native Regional Corporations with land and resource interests in the Pebble Project area, and 24 Alaska Native Village Corporations in the Bristol Bay region of southwest Alaska.

Surface lands owned by Alaska Native Village Corporations in the Bristol Bay region of southwest Alaska are shown in Figure 1.10.3.

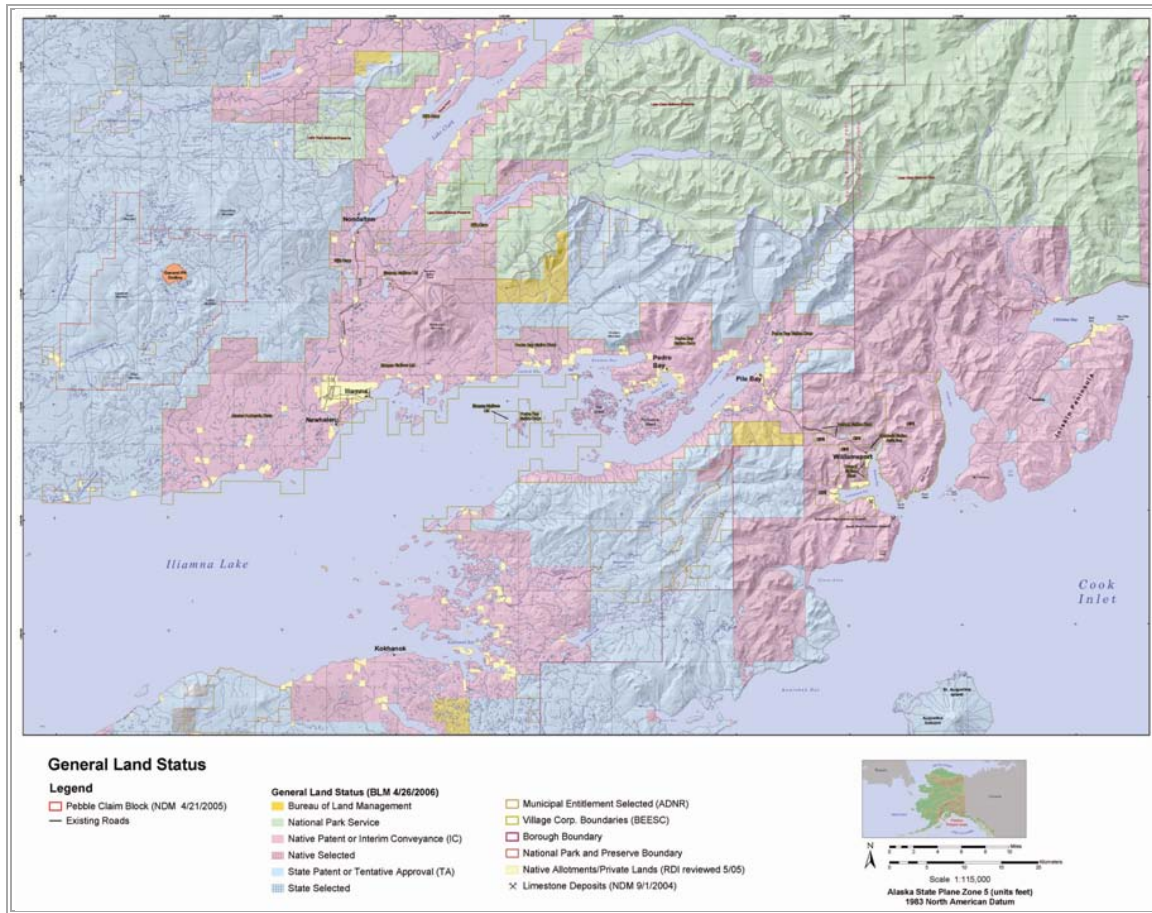
**Figure 1.10.3 Alaska Village Corporation Lands in Southwest Alaska**



Two Alaska Native Village Corporations – Iliamna Natives Ltd. and Pedro Bay Corporation – hold surface rights for significant areas of land along the Pebble Project transportation corridor. The Pebble Partnership has developed commercial relationships with these and other Alaska Native Village Corporations in the project area.

Land ownership status in the Pebble Project area, including the transportation corridor and port site, is shown in Figure 1.10.4. The Pebble deposit and claims area is located on State land specifically designated for mineral exploration and development within the Bristol Bay Area Plan.

Figure 1.10.4 General Land Status in the Pebble Project Area



### 1.10.6 STAKEHOLDER AND COMMUNITY RELATIONS

Since 2004, a comprehensive stakeholder relations and community outreach program has been undertaken in support of the Pebble Project. In addition to ensuring that relevant stakeholder groups and individuals receive early notification of all work programs, the objectives of the Pebble Partnership’s stakeholder and community relations program are:

- to provide regular progress updates on project-related activities, opportunities and planning;
- to seek input on stakeholder priorities, issues and concerns, and provide feedback on how they are being addressed;
- to educate stakeholders on responsible resource development and modern mining principles and practices;
- to maximize economic and community benefits associated with the Pebble Project, both in the exploration and development phase and during mine operations; and
- to provide opportunities for two-way dialogue and the development of long-term, respectful and mutually beneficial relationships.

Since 2004, the Pebble Partnership has undertaken more than 4,000 formal and informal meetings with stakeholder groups and individuals. All meetings have been recorded and stakeholder input documented. In certain cases, translation services have been utilized to ensure Native elders can participate in stakeholder consultation exercises.

The Pebble Partnership's stakeholder and community relations program contains a number of other elements.

#### PUBLIC EDUCATION

As part of its mandate to enhance stakeholder understandings of responsible resource development, the Pebble Partnership has designed and delivered a multi-faceted public education program. This includes a comprehensive tour program to allow project stakeholders to learn about mineral development activities through visits to operating and reclaimed mine sites. Through 2010, some 350 tours have been executed to provide more than 2,000 stakeholders with first-hand experience of the mining industry, including 15 visits to operating mines in Alaska, other U.S. states, Canada and Chile.

#### COMMUNITY INVESTMENT

The Pebble Partnership has committed significant funds to provide opportunity and improve the quality of life in Bristol Bay communities. Community investments range from small grants to charities and other groups providing valuable services to local communities, to larger investments to support significant community infrastructure projects. In 2008, the Pebble Partnership established the *Pebble Fund* – a five-year, \$5 million endowment to enhance the health and sustainability of local communities. To the end of 2010, the *Pebble Fund* has supported 65 projects throughout Bristol Bay, directly investing more than \$2.4 million and leveraging nearly \$12 million in matching funds from other organizations.

#### TRAINING AND WORKFORCE DEVELOPMENT

The Pebble Partnership has made an explicit commitment to maximize local employment at the Pebble Project, both at the exploration stage and during mine operations. The company is pursuing this goal by ensuring local residents receive priority consideration for employment, based on qualifications and merit, and advancing training and workforce development initiatives. A long-term Workforce Development strategy is currently being developed to ensure that skills training, professional development and other programs are in place to maximize the number of Bristol Bay and Alaska residents that secure jobs in the lead-up to and during mine operations.

#### BUSINESS DEVELOPMENT

Programs to enhance the capacity of local businesses to provide goods and services to the Pebble Project, and to position themselves to benefit from mine operations in future, have been advanced since 2005. In particular, these programs have focused on Alaska Native Village Corporations in the project area. The Pebble Partnership has developed commercial relationships with five Alaska Native Village Corporations: Iliamna Natives Limited/Iliamna Development Corporation; Pedro Bay Corporation; Alaska Peninsula Corporation; Kijik Corporation; and Igiugig Natives Ltd. These

partnerships have generated local employment, training and revenue for participating corporations, and allowed them to develop the human and financial resources necessary to capture additional business opportunities in future.

A comprehensive Business Development strategy is currently being developed to ensure that local businesses, including Alaska Native corporations, are aware of long-term business opportunities and can position themselves to benefit from mine operations. This includes opportunities to outsource major components of project-related transportation and power infrastructure.

The Pebble Project will generate significant direct and indirect employment, business/economic activity and government revenues in the Bristol Bay region, the State of Alaska and the United States. The Pebble Partnership has a stated intent to maximize project benefits for the residents and communities of southwest Alaska, and is developing long-term workforce and business development strategies to realize this goal.

Transportation and energy infrastructure development associated with the Pebble Project also has the potential to deliver significant benefits for communities in southwest Alaska, by lowering the cost of living for local residents and supporting economic growth and diversification. Meaningful benefits associated with power generation and transmission, in particular, could be extended to communities throughout the Bristol Bay region.

## 1.11 FINANCIAL AND COST ANALYSIS

---

Financial results for all three development cases presented in this Preliminary Assessment have been prepared based on a nominal 200,000 tons per day milling capacity. However, actual plant capacity in each fluctuates with the variations in ore hardness and the average throughputs are 219,000 tons per day in the 25-year IDC Case and 229,000 tons per day in the 45-year Reference and 78-year Resource Cases. All amounts expressed are in US dollars in real terms. The valuation date on which the NPV, IRR and other financial results are based is at the commencement of project construction.

### 1.11.1 KEY ECONOMIC ASSUMPTIONS

Key economic assumptions used in all financial analyses in this section are outlined in Table 1.11.1. Annual cash flows have been calculated and subsequently discounted at a rate of 7%. Market convention generally uses a discount rate of 8% for copper and other base metal projects and 5% for gold and other precious metal projects. Given the large contribution of gold to total metal value at the Pebble Project, a 7% blended discount rate has been selected by Wardrop and is considered appropriate for discounting the Pebble Project cash flows for discounted cash flow analysis purposes.

The discounted cash flow analysis for each of the three development cases presented in this Preliminary Assessment considers:

- annual recovered metal production statistics, incorporating tonnage milled, head grades and recoveries;



- long-term prices for copper, gold, molybdenum, silver, rhenium and palladium as above, adjusted to realize price levels by applying smelting, refining and concentrate transport charges;
- fixed and variable operating costs; and
- initial and sustaining capital costs.

**Table 1.11.1 Pebble Project – Key Economic Assumptions**

Metal Type	Unit	Value	
Discount Rate	%	7.0	
<b>Metal Prices</b>		<b>Long-term</b>	<b>Current Prevailing</b>
Copper	\$/lb	2.50	4.00
Gold	\$/oz	1,050	1,350
Molybdenum	\$/lb	13.50	15.00
Silver	\$/oz	15.00	28.00
Rhenium	\$/kg	3,000	3,000
Palladium	\$/oz	490	490
<b>Smelter Terms</b>			
Treatment Charges	\$/DMT	70	
Copper Refining Charges	\$/lb	0.070	
Gold Refining Charges	\$/oz	5.0	

**PRODUCTION**

Production results for all three development cases presented in this Preliminary Assessment are shown in Table 1.11.2.

**Table 1.11.2 Pebble Project – Production Summary All Cases**

Item	Unit	IDC Case	Reference Case	Resource Case
Mine Life	years	25	45	78
Mining Method		Open Pit	Open Pit	Open Pit
Production Rate	M ton/year	80	84	84
Strip Ratio	waste : ore	1.5	2.1	2.6
Total Processed	M ton	1,990	3,767	6,528
% of M+I+I Resource	%	17	32	55
Copper Eq. Grade	%	0.72	0.83	0.84
Copper Grade	%	0.38	0.46	0.46
Gold Grade	oz/ton	0.012	0.011	0.011
Molybdenum Grade	ppm	182	214	243
Copper Recovery	%	86.6	87.9	88.4
Gold Recovery	%	71.5	71.3	71.2
Molybdenum Recovery	%	84.8	87.9	89.4

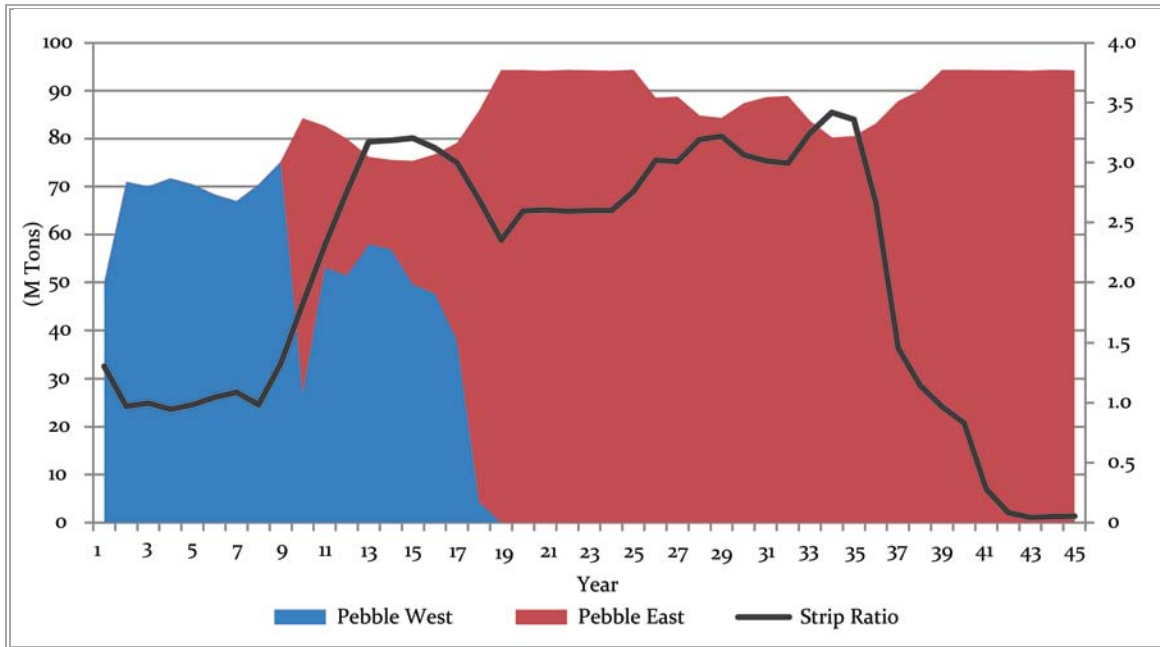
Table continues...

...Table 1.11.2 (cont'd)

Item	Unit	IDC Case	Reference Case	Resource Case
Copper Equivalent Recovered	M lb	24,483	54,129	96,357
Copper Recovered	M lb	12,944	30,494	53,437
Gold Recovered	k oz	16,391	30,307	50,133
Molybdenum Recovered	M lb	616	1,420	2,835
Peak Annual Copper Recovered	M lb	822	1,157	1,096
Peak Annual Gold Recovered	k oz	1,038	1,127	1,088
Peak Annual Molybdenum Recovered	M lb	43	56	62
Avg Annual Copper Recovered	M lb	518	678	685
Avg Annual Gold Recovered	K oz	656	673	643
Avg Annual Molybdenum Recovered	M lb	25	32	36
26% Cu Concentrate Produced	k dmt	22,582	53,200	93,225
52% Mo Concentrate Produced	k dmt	537	1,239	2,473

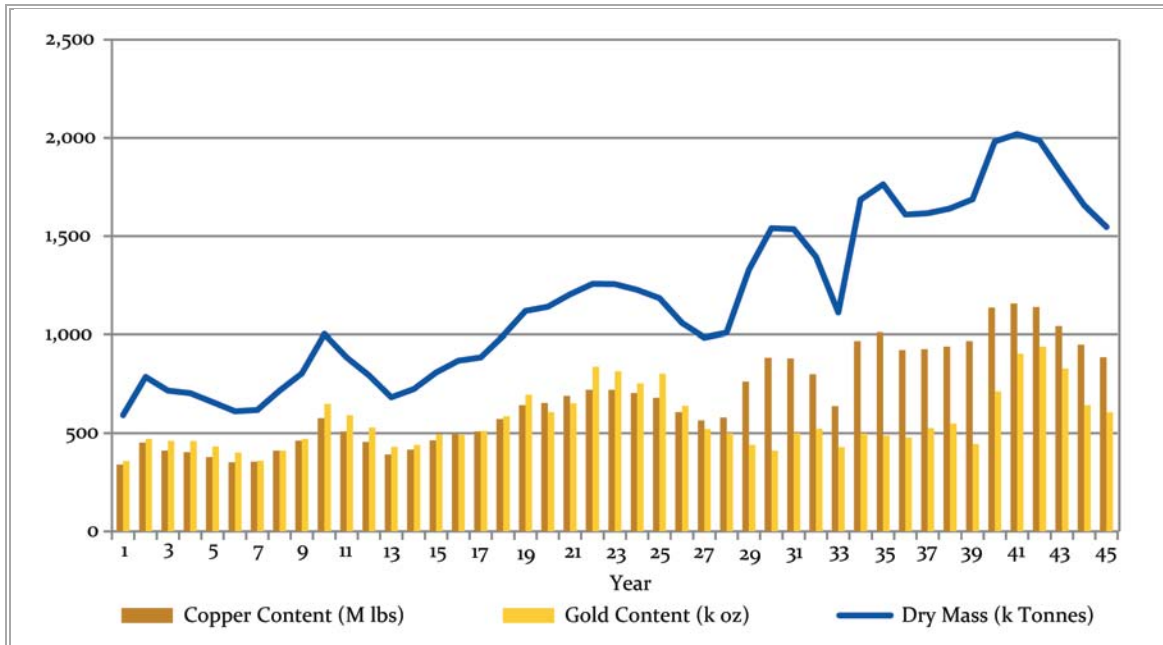
Annual production tonnages and strip ratio for the 45-year Reference Case are illustrated in Figure 1.11.1.

**Figure 1.11.1 Pebble Project – 45-Year Reference Case Tons Milled and Strip Ratio**



The production of copper-gold concentrate, along with contained copper and gold metal, for the 45-year Reference Case is shown in Figure 1.11.2.

**Figure 1.11.2 Pebble Project – 45-Year Reference Case Copper-Gold Concentrate Production**



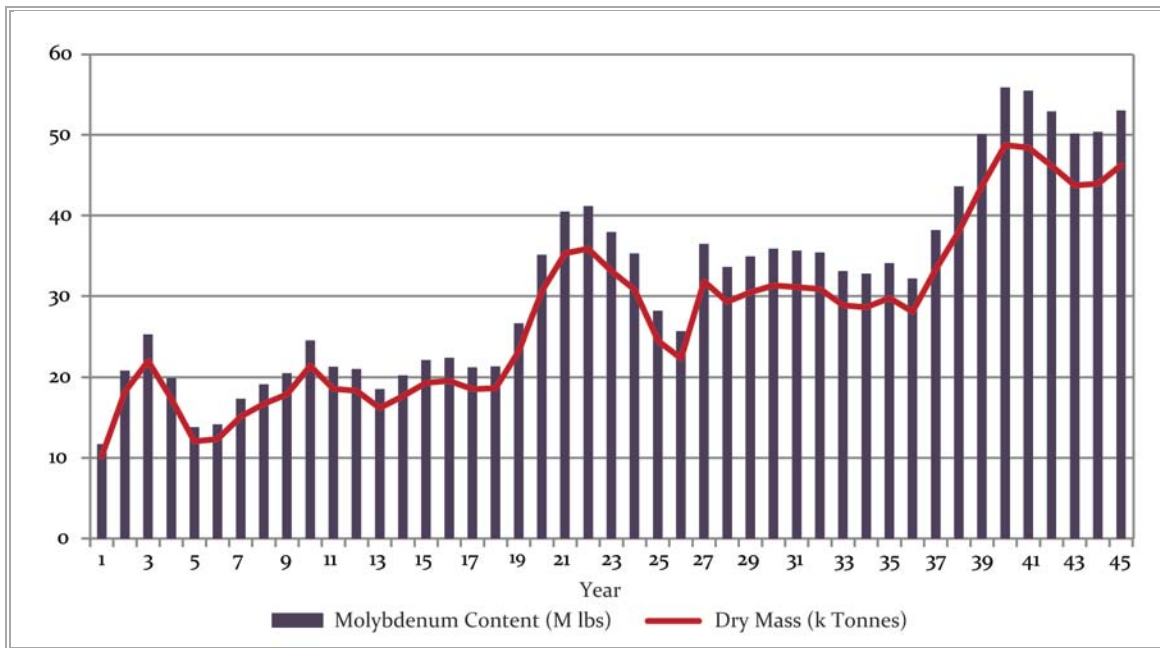
Copper, gold, silver and palladium grades within the copper-gold concentrate for all development cases are shown in Table 1.11.3.

**Table 1.11.3 Pebble Project – Copper-Gold Concentrate Statistics – All Cases**

Description	Unit	IDC Case	Reference Case	Resource Case
Cu-Au Concentrate Produced	k dmt	22,582	53,200	93,225
Copper Grade	% Cu	26.0	26.0	26.0
Gold Grade	g/dmt	18.9	15.9	14.7
Silver Grade	g/dmt	79.8	71.8	69.5
Palladium Grade	g/dmt	0.53	0.53	0.53
Moisture Content	%	7.5	7.5	7.5

Molybdenum concentrate and molybdenum metal production for the 45-year Reference Case is shown in Figure 1.11.3.

Figure 1.11.3 Pebble Project – 45-Year Reference Case Molybdenum Concentrate Content



Molybdenum and rhenium grades within the molybdenum concentrate for the 45-year Reference Case are shown in Table 1.11.4.

Table 1.11.4 Pebble Project – Molybdenum Concentrate Statistics – All Cases

Description	Unit	IDC Case	Reference Case	Resource Case
Mo Concentrate Produced	k dmt	537	1,239	2,473
Molybdenum Grade	% Mo		52.0	
Rhenium Grade	ppm		1,100	
Moisture Content	%		7.5	

### 1.11.2 CAPITAL COST ESTIMATES

All three development cases presented in this Preliminary Assessment have the same initial capital requirement of \$4.7 billion. This includes:

- direct field costs for executing the project;
- indirect costs associated with the design, construction and commissioning of new facilities;
- owner’s support costs for corporate, environmental, permitting and staffing;
- capital costs to completion of construction and commissioning at the end of Year -1; and
- contingencies.

The capital cost estimate has been developed over a series of project stages and is largely based on first principles estimates. Quantities have been derived for project components for which productivity and

labour rates have been estimated for specific trades. As a result, the capital cost estimate approaches a pre-feasibility level of accuracy.

It has been assumed in the financial evaluation that the Pebble Partnership will enter into strategic partnerships as needed to develop, finance and operate a number of infrastructure assets – including the transportation corridor (port & road) and the power plant.

Each financial case assumes that the Pebble Partnership will construct a molybdenum autoclave plant offshore to treat the molybdenum concentrate, and thereby realize enhanced value through improved pricing for rhenium and copper recovery.

The contingency estimate has been compiled from a risk matrix applied to all estimated areas and further refined by applying a weighting factor to each contingency based on relative cost magnitude. The result is an overall capital cost contingency of 17.7%.

The estimated initial capital cost breakdown of \$4.7 billion, which is the same for all three development cases, is shown in Table 1.11.5.

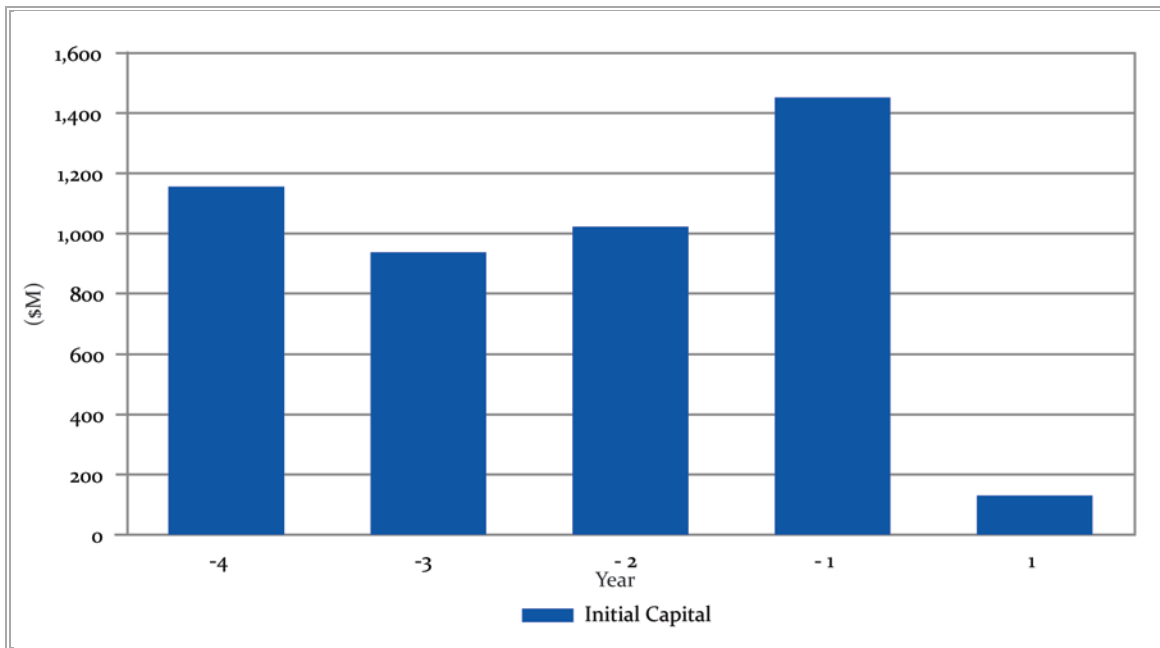
**Table 1.11.5 Pebble Project – Initial Capital – All Cases**

Area	Cost (\$M)
Mining	430.8
Process	1,058.2
Molybdenum Separation	83.5
Secondary Gold Plant	160.5
Other Infrastructure	422.0
Tailings	294.0
Pipelines	97.5
Access Road*	162.0
Port Infrastructure*	154.5
Port Process	87.1
Power Generation*	534.1
Indirect costs	1,406.8
Contingency	865.7
<b>Total Capital Cost Estimate</b>	<b>5,756.7</b>
Molybdenum Autoclave	374.2
Escalation/De-escalation Adjustments	(121.1)
Less: outsourced Infrastructure*	(1,315.0)
<b>Initial Capital – Financial Model</b>	<b>4,694.8</b>

\*Outsourced infrastructure, including associated indirects and contingencies.

The phasing of initial capital expenditures is illustrated in Figure 1.11.4. Initial capital is defined as all capital expenditure incurred before the process plant is ready for its first feed (end of 4<sup>th</sup> year of construction). The capital plan estimates that approximately \$100 million of Year -4 mining equipment (including indirect costs) will have to be ordered in advance of the construction commencement date.

**Figure 1.11.4 Pebble Project – Initial Capital Phasing – All Cases**



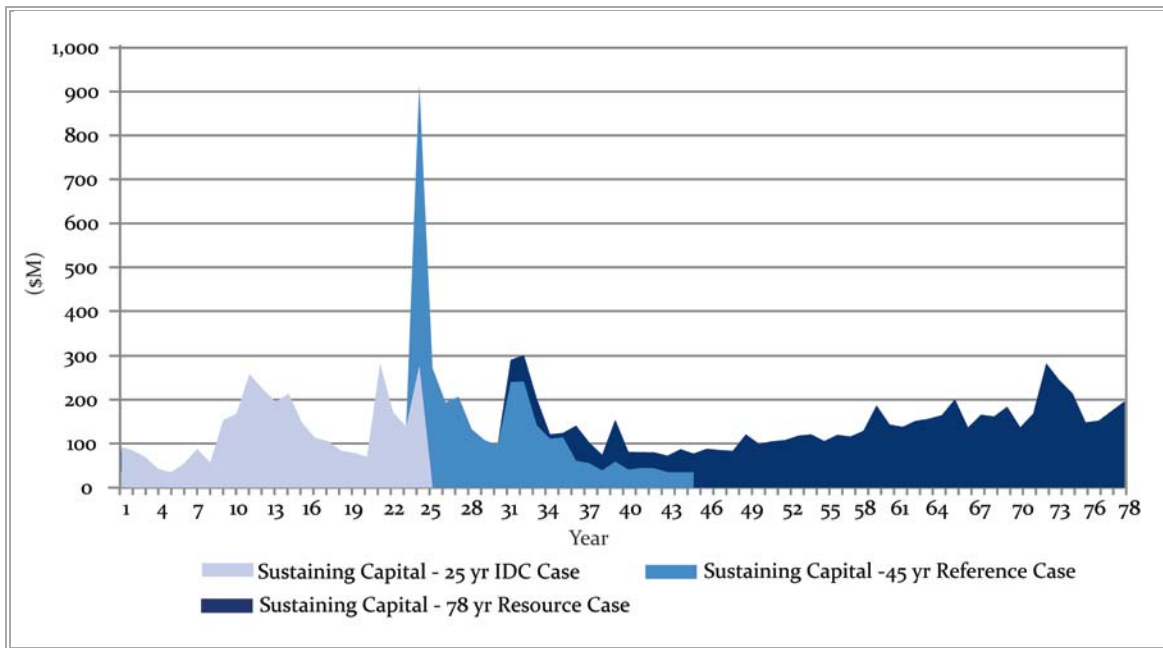
Sustaining capital requirements for the Pebble Project for all three development cases are shown in Table 1.11.6.

**Table 1.11.6 Pebble Project – Sustaining Capital Costs (\$M) – All Cases**

Area	IDC Case	Reference Case	Resource Case
Open Pit	2,047	3,286	7,225
Processing	146	230	517
Infrastructure	12	165	165
Waste Management	846	2,211	3,364
Other	70	104	180
Molybdenum Autoclave	83	144	276
<b>Total</b>	<b>3,204</b>	<b>6,140</b>	<b>11,727</b>

The sustaining capital profile for the 45-Year Reference Case and the 78-year Resource Case continue the assumptions of sustaining capital requirements for the 25-year IDC Case. The phasing of all three cases is illustrated in Figure 1.11.5, with each development case building off assumptions of the preceding case.

**Figure 1.11.5 Pebble Project – Sustaining Capital Phasing – All Cases**



**1.11.3 OPERATING COST ESTIMATE**

Life of mine unit operating costs are estimated at \$11.16/ton milled for the 25-year IDC Case, \$11.55/ton milled for the 45-year Reference Case and \$14.72/ton milled for the 78-year Resource Case. This includes all costs associated with open pit mining of ore and waste, processing of ore to a final concentrate and all services required to support this operation. This estimate has been prepared as an annual cost for each year of the project from plant start-up to mine closure. Operating costs are based on estimated process plant throughput rates, which range depending on the grindability of the ore fed to the process plant. For the 25-year IDC Case, the average processing rate is 219,000 tons per day; for the 45-year Reference and 78-year Resource cases, the figure is 229,000 tons per day.

**Table 1.11.7 Pebble Project – Operating Cost – All Cases**

Description	Unit	IDC Case	Reference Case	Resource Case
Total Operating Costs	\$M	22,208	43,489	96,063
Open Pit	\$/ton	3.83	4.30	7.19
Process	\$/ton	4.50	4.60	4.93
Transportation	\$/ton	0.97	0.91	0.91
Environmental	\$/ton	0.30	0.29	0.31
G&A	\$/ton	1.56	1.45	1.38
<b>Total Operating Costs Per Ton Milled</b>	<b>\$/ton</b>	<b>11.16</b>	<b>11.55</b>	<b>14.72</b>

Unit operating costs for the 45-year Reference Case are summarized in Table 1.11.8.

**Table 1.11.8 Pebble Project – Operating Cost Per Ton – 45-Year Reference Case**

Item	Labour	Power	Material	Fuel	Lease Costs	Other	Total
Open Pit Mining	0.75	0.06	2.32	1.17	-	-	4.30
Process (incl. Gold Plant)	0.38	1.19	2.46	0.02	-	0.02	4.07
Tailings	0.13	0.15	0.18	0.07	-	-	0.53
Transportation	-	0.01	0.01	0.02	0.35	0.53	0.92
Environmental	0.03	0.02	0.20	-	-	0.04	0.29
G&A	0.31	0.02	-	0.01	0.78	0.32	1.44
<b>Total</b>	<b>1.60</b>	<b>1.45</b>	<b>5.17</b>	<b>1.29</b>	<b>1.13</b>	<b>0.91</b>	<b>11.55</b>

The Pebble Project will employ a significant work force, as shown in Table 1.11.9. The Pebble Partnership has stated its intention to maximize local and Alaskan hire at the Pebble Project, and is developing a workforce development plan to accomplish this goal.

**Table 1.11.9 Operating Personnel**

Item	Year 2	Year 18
Mill Site	747	1,196
Port Site	32	32
Off Site	51	50
<b>Total Staff</b>	<b>830</b>	<b>1,278</b>

#### 1.11.4 CASH COST

Costs of ocean freight for the transportation of final concentrate to off-shore smelters, as well as associated smelter charges, are included in offsite charges (realization costs). These costs have been deducted from gross revenues to determine NSR. Teck's NPI royalty and production taxes have not been deducted in determining the NSR, as they are generally derived from profits.

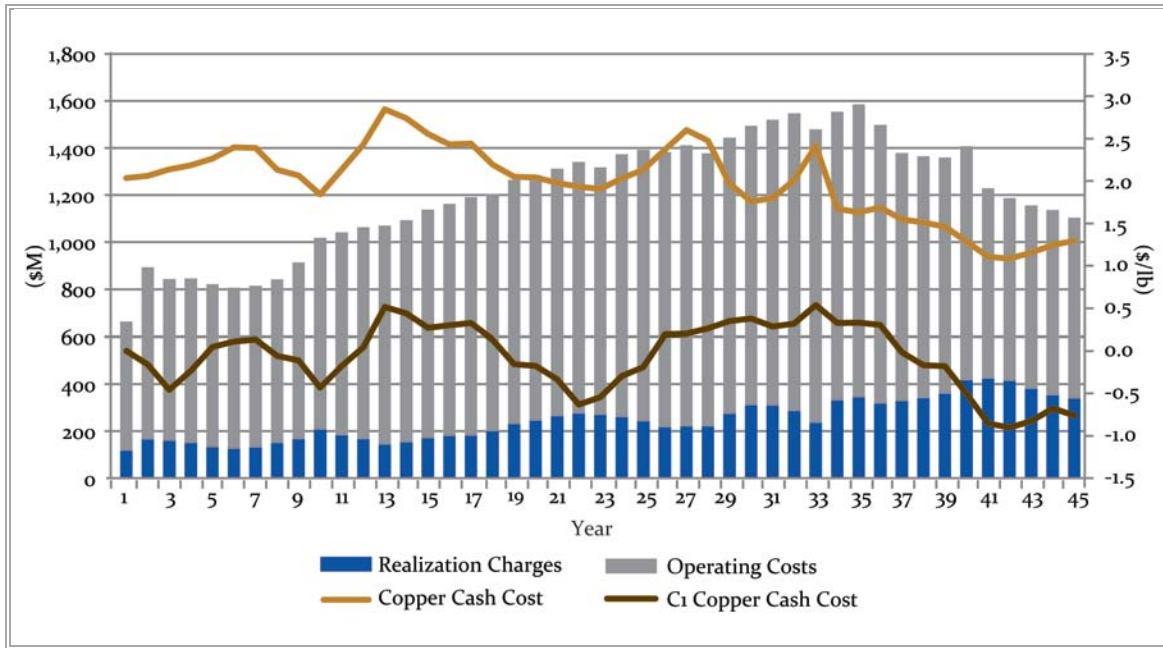
**Table 1.11.10 Pebble Project – Cash Costs – All Cases**

Description	Unit	IDC Case	Reference Case	Resource Case
<b>Offsite Charges</b>				
Total Offsite Charges	\$M	4,752	11,089	19,938
Offsite Charges per ton milled	\$/ton	2.39	2.94	3.05
<b>Cash Cost Analysis</b>				
Offsite Charges	\$/lb	0.38	0.38	0.39
Operating Costs	\$/lb	1.79	1.48	1.87
Copper Cash Cost	\$/lb	2.17	1.86	2.26
By-Product Credits	\$/lb	-2.27	-1.97	-2.05
C1 Copper Cost*	\$/lb	-0.10	-0.11	0.21

\*C1 copper cost is the cash cost per payable pound of copper after 5-product credit.



**Figure 1.11.6 Cash Cost – 45-Year Reference Case**



**1.11.5 NET SMELTER RETURN**

The composition of NSR statistics for the Pebble Project is shown in Table 1.11.11.

**Table 1.11.11 Pebble Project – Net Smelter Return – All Cases**

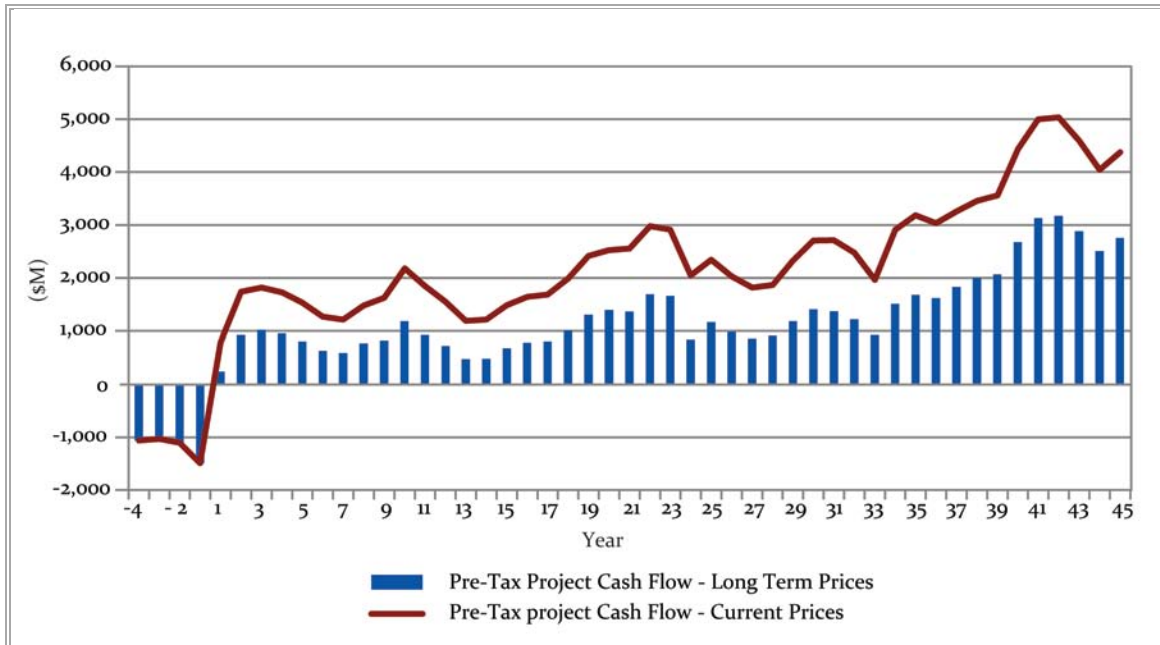
Description	Unit	IDC Case 25 Years	Reference Case 45 years	Resource Case 78 years
NSR LOM	\$M	54,637	120,197	213,970
NSR Annual Average	\$M	2,185	2,671	2,743
Copper	%	52	55	55
Gold	%	29	24	22
Molybdenum	%	15	16	18
Other	%	4	5	5
NSR per ton milled	\$/ton	27.45	31.91	32.78

**1.11.6 PROJECT CASH FLOWS**

The three successive development cases presented in this Preliminary Assessment have capital payback periods ranging from 6.1 to 6.5 years. These differences are a function of the varying reclamation and closure plans for each of the development cases, and associated financial surety obligations. Pebble Project pre-tax cash flows at long-term and current prevailing metal prices are illustrated in Figure 1.11.7.

For the 45-year Reference Case, cash flows in real terms increase in the last ten years due to the reduced stripping ratio and increasing grade of the Pebble East zone.

**Figure 1.11.7 Pebble Project – 45-Year Reference Case Pre-Tax Cash Flows (\$M)**



**1.11.7 PEBBLE PROJECT FINANCIAL RESULTS**

Based on long-term forecast metal prices, pre-tax financial results for the three successive development cases presented in this Preliminary Assessment are summarized below:

The 45-year Reference Case yields a 14.2% pre-tax internal rate of return (IRR), a 6.2 year payback and a \$6.13 billion pre-tax NPV at a 7% discount rate.

The 25-year IDC Case yields a 13.4% pre-tax IRR, a 6.5 year payback and a \$3.84 billion pre-tax NPV at a 7% discount rate.

The 78-year Resource Case yields a 14.5% pre-tax IRR, a 6.1 year payback and a \$6.81 billion pre-tax NPV at a 7% discount rate.

These financial results, as well as financial results for all three development cases at current prevailing metal prices are summarized in Table 1.11.12.

**Table 1.11.12 Pebble Project – Summary Financial Results – All Cases**

Item	Unit	IDC Case	Reference Case	Resource Case
Mine Life	years	25	45	78
Mining Method		Open Pit	Open Pit	Open Pit
Initial Capital	\$M	4,695	4,695	4,695
NSR per ton	\$/ton	27.45	31.91	32.78
Operating Cost per ton	\$/ton	11.16	11.55	14.72
Copper Cash Cost	\$/lb	2.17	1.86	2.26
C1 Copper Cost	\$/lb	-0.10	-0.11	0.21
<b>Long-term Metal Prices</b>				
Pre-Tax NPV at 7%	\$M	3,837	6,129	6,812
Pre-Tax IRR	%	13.4	14.2	14.5
Pre-Tax Payback	years	6.5	6.2	6.1
<b>Current Prevailing Metal Prices</b>				
NSR per ton	\$/ton	40.13	46.98	47.96
C1 Copper Cost	\$/lb	-0.63	-0.55	-0.22
Pre-Tax NPV at 7%	\$M	11,410	15,709	16,864
Pre-Tax IRR	%	22.6	23.2	23.3
Pre-Tax Payback	years	3.2	3.2	3.2

Notes:

Pre-tax results are before income taxes but after NPI royalty and local production taxes

C1 Copper Cost is Copper Cash Cost (Operating Costs plus Realization Costs) after by-product credits

Long-term metal prices used for the financial analysis were \$2.50/lb for copper, \$1050/oz for gold, \$13.50/lb for molybdenum, and \$15.00/oz for silver. Current prevailing metal prices used for the financial analysis were \$4.00/lb for copper, \$1350/oz for gold, \$15.00/lb for molybdenum, and \$28.00/oz for silver.

By prescribed definition, “Mineral Resources” do not have demonstrated economic viability. Measured and Indicated Resources are that part of a mineral resource for which quantity and grade can be estimated with a level of confidence sufficient to allow the application of technical and economic parameters to support mine planning and evaluation of the economic viability of the project. Inferred Mineral Resources are that part of a mineral resource for which quantity and grade can be estimated on the basis of geological evidence and limited sampling and reasonably assumed, but not verified, geological and grade continuity. Inferred Mineral Resources are considered to be too speculative to allow the application of technical and economic parameters to support mine planning and evaluation of the economic viability of the project. The mineral resources fall within a volume or shell defined by long-term metal price estimates of US\$2.50/lb for copper, US\$900/oz for gold and US\$25/lb for molybdenum.

### 1.11.8 NORTHERN DYNASTY ALLOCATION

Under the terms of the Pebble Limited Partnership Agreement, Anglo American is required to elect to continue its staged investment of \$1.425 to \$1.5 billion in order to retain its 50% interest in the Pebble Project. A significant portion of this earn-in contribution is expected to be applied to initial capital costs to construct the mine, thereby reducing Northern Dynasty’s capital requirement to maintain its 50% interest in the project.

In order to calculate an NPV and IRR estimate for Northern Dynasty’s 50% interest in the Pebble Project under this earn-in scenario, it is necessary to adjust Northern Dynasty’s share of initial capital

costs. For the purpose of this calculation, it is assumed that \$1 billion of Anglo American's current funding commitment will be applied to the Pebble Project's capital cost for construction.

As a partnership is not a taxable entity for US tax purposes, taxes payable on profits associated with development of the Pebble Project will accrue to each partner. For this reason, NPV, IRR and capital payback financial results have been presented on a pre-tax basis for the overall project.

Insofar as Northern Dynasty is in a position to calculate taxes payable for its portion of profits associated with development of the Pebble Project, financial results for Northern Dynasty's 50% interest in the project have been presented on a pre-tax and post-tax basis, and at long-term and current prevailing metal prices, in Table 1.11.13.

**Table 1.11.13 Northern Dynasty Pre- and Post-Tax Financial Results**

Item	Unit	IDC Case	Reference Case	Resource Case
<b>Long-term Metal Prices</b>				
Pre-Tax NPV at 7%	\$M	2,403	3,550	3,891
Pre-Tax IRR	%	17.3	18.0	18.4
Pre-Tax Payback	years	4.9	4.7	4.6
<b>Current Metal Prices</b>				
Pre-Tax NPV at 7%	\$M	6,190	8,339	8,917
Pre-Tax IRR	%	29.5	30.2	30.4
Pre-Tax Payback	years	2.7	2.6	2.6
<b>Long-term Metal Prices</b>				
Post-Tax NPV at 7%	\$M	1,559	2,358	2,650
Post-Tax IRR	%	14.6	15.4	15.8
Post-Tax Payback	years	5.6	5.3	5.3
<b>Current Metal Prices</b>				
Post-Tax NPV at 7%	\$M	4,141	5,561	6,002
Post-Tax IRR	%	24.5	25.1	25.4
Post-Tax Payback	years	3.1	3.1	3.0

### 1.11.9 NPV<sub>7</sub> AND METAL PRICE SENSITIVITIES

Table 1.11.14 illustrates the impact of various conventional discount rates on Northern Dynasty's post-tax NPV<sub>7</sub>. It also illustrates Northern Dynasty's post-tax NPV<sub>7</sub> sensitivity to a range of copper and gold prices, both individually and combined with other metal prices held constant.

**Table 1.11.14 Northern Dynasty Project – Post-Tax NPV<sub>7</sub> Sensitivities – All Cases**

Item	Unit	IDC Case	Reference Case	Resource Case
<b>Discount Rate</b>				
NPV at 0%	\$M	7,532	19,818	31,583
NPV at 5%	\$M	2,491	4,164	4,877
<b>NPV at 7%</b>	<b>\$M</b>	<b>1,559</b>	<b>2,358</b>	<b>2,650</b>
NPV at 8%	\$M	1,213	1,774	1,975
NPV at 10%	\$M	689	976	1,087
<b>Cu Price (Au \$1,050/oz, Mo \$13.50/lb)</b>				
<b>2.50</b>	<b>\$M</b>	<b>1,559</b>	<b>2,358</b>	<b>2,650</b>
2.75	\$M	1,893	2,776	3,089
3.00	\$M	2,226	3,192	3,525
3.25	\$M	2,557	3,605	3,955
3.50	\$M	2,874	4,006	4,375
3.75	\$M	3,188	4,404	4,792
4.00	\$M	3,499	4,796	5,201
4.25	\$M	3,802	5,181	5,605
<b>Au Price (Cu \$2.50/lb, Mo \$13.50/lb)</b>				
<b>1050</b>	<b>\$M</b>	<b>1,559</b>	<b>2,358</b>	<b>2,650</b>
1100	\$M	1,646	2,459	2,755
1150	\$M	1,733	2,560	2,860
1200	\$M	1,820	2,660	2,964
1250	\$M	1,906	2,760	3,068
1300	\$M	1,993	2,861	3,172
1350	\$M	2,079	2,961	3,276
1400	\$M	2,166	3,061	3,380
<b>Combined Cu and Au Price (Mo \$13.50/lb)</b>				
<b>2.50 / 1050</b>	<b>\$M</b>	<b>1,559</b>	<b>2,358</b>	<b>2,650</b>
2.75 / 1100	\$M	1,980	2,876	3,193
3.00 / 1150	\$M	2,399	3,391	3,732
3.25 / 1200	\$M	2,804	3,895	4,255
3.50 / 1250	\$M	3,200	4,389	4,771
3.75 / 1300	\$M	3,590	4,873	5,276
4.00 / 1350	\$M	3,971	5,350	5,776
4.25 / 1400	\$M	4,351	5,827	6,276

### 1.11.10 IRR AND METAL PRICE SENSITIVITIES

Table 1.11.15 illustrates Northern Dynasty's post-tax IRR sensitivity to a range of copper and gold prices both individually and combined with other metal prices held constant.

**Table 1.11.15 Northern Dynasty – Post-Tax IRR Sensitivities – All Cases**

Item	Unit	IDC Case 25 years	Reference Case 45 years	Resource Case 78 years
<b>Cu Price (Au \$1,050/oz, Mo \$13.50/lb)</b>				
2.50	%	14.6	15.4	15.8
2.75	%	16.0	16.7	17.1
3.00	%	17.3	18.0	18.4
3.25	%	18.6	19.3	19.6
3.50	%	19.9	20.5	20.8
3.75	%	21.1	21.6	22.0
4.00	%	22.2	22.8	23.1
4.25	%	23.3	23.9	23.9
<b>Au Price (Cu \$2.50/lb, Mo \$13.50/lb)</b>				
1050	%	14.6	15.4	15.8
1100	%	15.0	15.7	16.1
1150	%	15.4	16.1	16.5
1200	%	15.7	16.4	16.8
1250	%	16.1	16.8	17.2
1300	%	16.4	17.1	17.5
1350	%	16.8	17.4	17.8
1400	%	17.1	17.8	18.2
<b>Combined Cu and Au Price (Mo \$13.50/lb)</b>				
2.50/1050	%	14.6	15.4	15.8
2.75 / 1100	%	16.4	17.0	17.4
3.00 / 1150	%	18.0	18.7	19.0
3.25 /1200	%	19.6	20.2	20.5
3.50 / 1250	%	21.1	21.7	22.0
3.75 / 1300	%	22.6	23.1	23.4
4.00 / 1350	%	23.9	24.5	24.8
4.25 / 1400	%	25.3	25.8	26.1

## 1.12 RECOMMENDATIONS AND OPPORTUNITIES

---

### 1.12.1 RESOURCE

The resources at Pebble continue to provide a number of opportunities.

#### EASTERN EXTENSION

The mineralization surrounding the 1,000 ft high grade intersection in hole 6348 is still open. This represents a significant opportunity to expand the highest grade portion of the Pebble deposit at depth, to the east.

#### ADDITIONAL DEPOSITS

A number of deposits have been identified on the property, including a higher grade gold zone. Additional low grade gold mineralization has been identified and a number of geophysical anomalies have yet to be tested. These exploration targets could further enhance the project by changing the gold production levels and by providing options for future project expansion.

#### SILVER

A number of areas of the deposit have superior silver grades. The mine plan has not been optimized for silver and this should be assessed during the next phase of study.

### 1.12.2 MINING

#### GENERAL

The Pebble deposit is very large, and even the 78-year Resource Case would exploit only 55% of the total resource. This deposit scale affords a number of opportunities over the long term to optimize the project over its life or to change the mine plan in response to short to medium term changes in markets or other factors. This would enable future mine planners to consider exploiting different parts of the deposit for higher grades of, for example, silver if the silver price is high; to evaluate production expansions; and to assess potential underground operations.

#### OPEN PIT

##### *Pit Optimization*

The open pit shells used in this study have been generated using parameters developed in early 2009. A number of these parameters (e.g. metal prices, operating costs) have seen significant improvement since that time. These changes may have a beneficial impact on the pit development sequence and should be incorporated into the pit optimization during the next study phase. The other optimization parameters should also be confirmed as part of this process.

### *Pit Wall Slopes*

The Pebble Partnership has reviewed the impact of changes to the current pit wall slopes. The upper sections, through overburden and the immediately underlying frost-shattered bedrock, may have to be flattened. However, the rock sections, particularly those in the higher eastern walls, could be steepened from the current 39° slope to 41°.

Slope changes of this order could result in a net waste rock reduction in the 25-Year IDC Case open pit by approximately 30 million tons. This benefit will be much greater in the 45-Year Reference and 78-year Resource Cases, both of which exploit more of the deeper ore to the east.

### *Optimize Production Forecast*

There is an extended period of low stripping beyond year 45 in the 78-Year Resource Case, which indicates the sequencing of the 45-year open pit could be optimized by reducing the strip ratio leading into the mining of the later ore. Further, the value demonstrated by the 78-Year Resource Case demonstrates that running the pit optimization over the life of the project may also further increase the project returns.

### *Automation*

The use of autonomous trucks has been shown to add significant value to the Pebble Project. Additional automation opportunities, such as blasthole drilling, would likely have analogous benefits.

## UNDERGROUND

A potential underground mine has not been considered as a primary case in this study. Further assessment of this option is warranted to evaluate methodologies of enhancing relative economics of an underground mine and confirming its performance.

### **1.12.3 PROCESS**

#### AUTOMATION

Plant automation may provide future opportunities.

#### SAG MILL SIZE

The current SAG mill size – 40 ft diameter – was selected because it was the largest mill currently in operation. However, a 42 ft diameter mill has recently been ordered for another project. The improved throughput from a larger mill diameter would further enhance the NPV of the project by a significant amount.



## GOLD RECOVERY

Other copper-gold porphyry projects within the global mining industry report higher gold recoveries than the 71% currently projected for Pebble. Additional work should be undertaken to optimize gold recovery, as a 5% increase to 76% recovery would further enhance the NPV of the 45-Year Reference Case by \$300 million, based on the sensitivity analysis.

Gold recoveries would be increased by reducing the copper-gold concentrate copper grade; trade-off analysis of this opportunity should be conducted during the next phase of the study.

## GRINDING CIRCUIT

In the current grinding circuit layout, crushed pebbles are returned to the SAG mill (SABC-A circuit). However, depending on the characteristics of the plant feed at a given time, this arrangement may underutilize the capacity of the mills. An analysis has been completed which shows the option of returning the crushed pebbles to the ball mills (SABC-B circuit) could increase mill throughput by 5% - 10%. A 5% improvement in throughput would increase NPV for the 45-year Reference Case by \$600 million.

## PRODUCTION INCREASE

The scale of the resource would enable processing of a much higher daily ore throughput; previous analysis has shown beneficial financial impacts of such expansions. Such results warrant further study as the project progresses through subsequent study phases.

### 1.12.4 INFRASTRUCTURE

#### PORT

Alternative port construction techniques should be evaluated, such as building the facility as caissons which could be towed to site and ballasted to the seafloor.

#### OTHER OUTSOURCING OPPORTUNITIES

In this Preliminary Assessment, only the three primary infrastructure components – access road, port and power generation – were considered for outsourcing to third party providers. However, a wide range of other opportunities exist, which could both improve the project economics and provide additional opportunities for local businesses. Some of these were considered in the study, such as air transport to local villages, but others include:

- concentrate and water return pipelines;
- mine and port site accommodations facilities;
- freight transport between Port Site 1 and the mine site;
- local transportation, at the mine site and between the mine site and local villages;

- turn-key fuel supply; and
- mine equipment maintenance.

These opportunities should be further examined during subsequent study phases.

### 1.12.5 PROJECT EXECUTION AND OPERATION

#### DEVELOPMENT SCHEDULE

Under the current schedule, project construction would require four years. A number of options, such as enhancing early mobilization, should be explored to identify potential opportunities for reducing this period. In addition, although the cost improvement for modularization was included in the project capital cost, the schedule improvements were not. This should be corrected in the next round of study, as a one year schedule reduction could further increase the NPV for the 45-Year Reference Case by \$400 million.

#### CONSTRUCTION CASH FLOW

A significant opportunity to improve project NPV exists by optimizing the cash flow during project implementation. This should be further evaluated during the next phase of study.

#### RAMP-UP

The production plan utilizes standard McNulty Curve ramp-up targets for the process plant, resulting in an 18 month period from initial to full production. This has a significant impact on project NPV and thus identifying options for improving ramp-up will provide superior results.

#### SUSTAINING CAPITAL

The level of sustaining capital, particularly in later mine life years, should be evaluated to confirm it is required. In particular, the mining equipment life cycle seems conservative and should be re-evaluated to ensure it meets current North American operating standards.

### 1.12.6 COSTS

#### COST ESCALATION

Many of the costs were derived or were estimated on the basis of information collected in 2008, which was a period of hyperinflation. Additional analysis should be conducted to determine if additional savings are possible.

#### CONTINGENCY

The capital cost contingency level of 17.7% is appropriate for a concept-level study. However, much of the engineering to support this study was done at a level superior to a concept-level study and in a

number of instances approaches prefeasibility accuracy. For the 45-year Reference Case, each reduction of 1% in the contingency estimate results in a \$42 million increase in the Pebble Project's pre-tax NPV<sub>7</sub>. During the next phase of study, particular attention should be paid to ensuring the contingency level matches the accuracy of the estimate.

### 1.12.7 CAPITAL COST

Wardrop has reviewed the methodology used to develop the capital cost estimate and believes, based on their experience, certain costs may have been overestimated. Wardrop completed a preliminary, high level estimate of the likely range of capital cost outcomes and a savings of some \$362 million from the current capital cost estimate was identified. A capital cost reduction of \$362 million would result in a 0.8% improvement in the pre-tax IRR for the Pebble project to 15%, and a \$313 million improvement in pre-tax NPV<sub>7</sub> to \$6,442 million. For Northern Dynasty, such a capital cost reduction for the project would result in an increase in its post-tax IRR of 1.3% to 16.7%, and an increase of \$128 million in its post-tax NPV<sub>7</sub> to \$2,486 million. As the project develops through subsequent phases Wardrop anticipates that further cost savings are possible through engineering optimization.

### POWER

The power cost of \$0.066/kWh was based on a natural gas price of \$7/mcf, which is considerably above the current price of approximately \$4/mcf. This gas price should receive particular attention during the next phase of study, as the power cost almost directly correlates to the natural gas price.

### 1.12.8 FINANCIAL ANALYSIS

#### REAL OPTIONS

The financial analysis was conducted using classic discounted cash flow techniques. These techniques demonstratively penalize long-life projects, which is enhanced in Pebble's case due to its very long life. Alternate techniques, such as Real Options, are available and in many instances in project assessments have shown the actual project results are likely to be much better than projected by discounted flows. A Real Options analysis should be conducted during the next phase of study to determine the extent to which the discounted cash flow treatment of uncertainty may be artificially understating the value of Pebble.

#### PRECIOUS METAL STREAMING

Many recently announced projects have included pre-sales of portions of their precious metal streams. Preliminary analysis of this option has shown that, under the correct circumstances, such pre-sales could add substantial economic value to the project. Precious metal financing strategies should be further studied during the next phase of the project.



## 2.0 INTRODUCTION

---

### 2.1 GENERAL

---

Northern Dynasty is a mineral exploration and development company based in Vancouver, Canada, and publicly traded on the Toronto Stock Exchange under the symbol NDM and on the NYSE Amex exchange under the symbol NAK. Northern Dynasty is affiliated with Hunter Dickinson Inc. (HDI), a diversified global mining company with a 25-year history of mineral development success.

Northern Dynasty holds indirect interests to 592 mi<sup>2</sup> of mineral claims in southwest Alaska, USA. Its principal asset is a 50% interest in the Pebble Limited Partnership – owner of the Pebble Copper-Gold-Molybdenum Project, consisting of the Pebble deposit and 330 mi<sup>2</sup> of associated mineral claims. The Pebble Partnership's assets also include access to a stream of financing for comprehensive exploration, engineering, environmental and socioeconomic programs to advance the Pebble Project toward permitting and operations.

The Pebble Partnership was established in 2007 by a wholly-owned affiliate of Northern Dynasty and a wholly-owned subsidiary of Anglo American plc, to engineer, permit, construct and operate a modern, long-life mine at Pebble. In order to retain its 50% interest in the Pebble Partnership, Anglo American is required to elect to continue its staged investment of US\$1.425 to \$1.5 billion to advance the Pebble Project.

Wardrop has been commissioned exclusively by Northern Dynasty to prepare a National Instrument 43-101 (NI 43-101) Preliminary Assessment Technical Report of the Pebble Project. This work is based on Wardrop's technical review of recent engineering and technical studies undertaken by the Pebble Partnership and NDM, as provided and verified by Northern Dynasty.

This report complies with the standards set out in NI 43-101 (Standards and Disclosure for Mineral Projects) and is in compliance with Form 43-101F1. A summary of the Qualified Persons responsible for each section of this report is given in Table 2.1.1. Certificates are included in this document.

A site visit was conducted by Mr. Hassan Ghaffari on September 1 and 2, 2010. Mr. Ghaffari was accompanied on the site visit by:

- Dr. Robert Sinclair Morrison, Lead Resource Geologist, Wardrop;
- Mr. Tysen Hantelmann, Senior Mining Engineer, Wardrop;
- Mr. David Gaunt, Vice President Resource and Database for HDI;
- Mr. Graham Kelsey, Chief Geologist for the Pebble Partnership; and
- Mr. Bryce Hamming, Vice President Corporate Finance for HDI.

The site visit was conducted from August 31 to September 2, 2010.

**Table 2.1.1 Summary of Qualified Persons**

Report Section	Qualified Person	
	Company	Qualified Person
1.0 – Executive Summary	Wardrop	Hassan Ghaffari, P.Eng.
2.0 – Introduction	Wardrop	Hassan Ghaffari, P.Eng.
3.0 – Reliance on Other Experts	Wardrop	Hassan Ghaffari, P.Eng.
4.0 – Property Description and Location	Wardrop	Robert Morrison, P.Geo.
5.0 – Accessibility, Climate, Local Resources, Infrastructure, and Physiography	Wardrop	Robert Morrison, P.Geo.
6.0 – History	Wardrop	Robert Morrison, P.Geo.
7.0 – Geological Setting	Wardrop	Robert Morrison, P.Geo.
8.0 – Deposit Types	Wardrop	Robert Morrison, P.Geo.
9.0 – Mineralization	Wardrop	Robert Morrison, P.Geo.
10.0 – Exploration	Wardrop	Robert Morrison, P.Geo.
11.0 – Drilling	Wardrop	Robert Morrison, P.Geo.
12.0 – Sampling Method and Approach	Wardrop	Robert Morrison, P.Geo.
13.0 – Sample Preparation, Analyses and Security	Wardrop	Robert Morrison, P.Geo.
14.0 – Data Verification	Wardrop	Robert Morrison, P.Geo.
15.0 – Adjacent Properties	Wardrop	Robert Morrison, P.Geo.
16.0 – Mineral Processing	Wardrop	Andre de Ruijter, P.Eng./ Hassan Ghaffari, P.Eng.
17.0 – Mineral Resource and Mineral Reserve Estimates	Wardrop	Robert Morrison, P.Geo.
<b>18.0 – Other Relevant Data and Information</b>		
18.1 – Mining	Wardrop	Tysen Hantelmann, P.Eng.
18.2 – Infrastructure	Wardrop	Hassan Ghaffari, P.Eng.
18.3 – Tailings, Waste Rock, and Water Management	Wardrop	Aleksandar Živković, P.Eng.
18.4 – Sustainability	Wardrop	Doug Ramsey, R.P.Bio.
18.5 – Capital Cost Estimate	Wardrop	Hassan Ghaffari, P.Eng., Tysen Hantelmann, P.Eng., Aleksandar Živković, P.Eng.
18.6 – Operating Cost Estimate	Wardrop	Andre de Ruijter, P.Eng., Tysen Hantelmann, P.Eng.
18.7 – Project Execution Plan	Wardrop	Hassan Ghaffari, P.Eng.
18.8 – Financial Analysis	Wardrop	Scott Cowie, MAusIMM
19.0 – Interpretation and Conclusions	Wardrop	All; sign off by discipline
20.0 – Opportunities and Recommendations	Wardrop	All; sign off by discipline

## 2.2 UNITS OF MEASUREMENT

---

The principal units of measure used in this report are Imperial. Monetary amounts are in United States dollars, unless otherwise stated.

## 2.3 SOURCES OF INFORMATION

---

Wardrop's detailed technical engineering review of the Pebble Project involved the analysis of third-party engineering reports for accuracy and detail relative to the following essential core elements of the project:

- resource estimate and block model;
- process design;
- mine plan and production schedule;
- financial models;
- sustainability and stakeholder relations;
- all site infrastructure;
- project execution plan and schedule; and
- capital and operating cost estimates.

Information from third-party sources is referenced under Section 21.0 (References). Wardrop has used information from these sources under the assumption that the information is accurate.

Additionally, Wardrop is relying on information found in the following report provided by Northern Dynasty:

- Rebagliati, C.M., Lang, J.R., Titley, E., Gaunt, J.D., Melis, L., Barratt, D., Hodgson, S., 2010. Technical Report on the 2009 Program and Update on Mineral Resources and Metallurgy. Pebble Copper-Gold-Molybdenum Project, Iliamna Lake Area, Southwestern Alaska, USA for Northern Dynasty Minerals Ltd. March, 2010. 194 pages.





### 3.0 RELIANCE ON OTHER EXPERTS

---

This Preliminary Assessment Technical Report has been prepared exclusively for Northern Dynasty Minerals by Wardrop. It is based on information and data provided by Northern Dynasty and certain other parties, as verified by Northern Dynasty. Where necessary, Wardrop has assumed that the supplied data and information is accurate and complete.

In some cases, Wardrop is relying on reports, opinions, and statements from experts who are not Qualified Persons for information concerning legal, environmental, permitting, socio-political and other issues and factors relevant to the technical report.

Wardrop has not conducted an examination of land titles or mineral rights for the property.

Otherwise, technical data used by Wardrop in this Technical Report has been exclusively provided and verified by Northern Dynasty Minerals based on work conducted, commissioned and supervised by Northern Dynasty and/or the Pebble Limited Partnership, their professional staff and consultants.



## 4.0 PROPERTY DESCRIPTION AND LOCATION

### 4.1 LOCATION

The Pebble property in southwest Alaska is centred at latitude 59°53'54"N and longitude 155°17'44"W, approximately 200 miles southwest of Anchorage, 17 miles northwest of the village of Iliamna, and 160 miles northeast of Bristol Bay (Figure 4.1.1). The property is located on USGS topographic maps, Iliamna D6 and D7, in Townships 2 - 5 South, Ranges 33 - 38 West, Seward Meridian (Figure 4.1.2).

The Pebble property uses the US State Plane Coordinate System (as Alaska 5005) as the preferred grid, measured in feet.

**Figure 4.1.1** Location Map for the Pebble Project



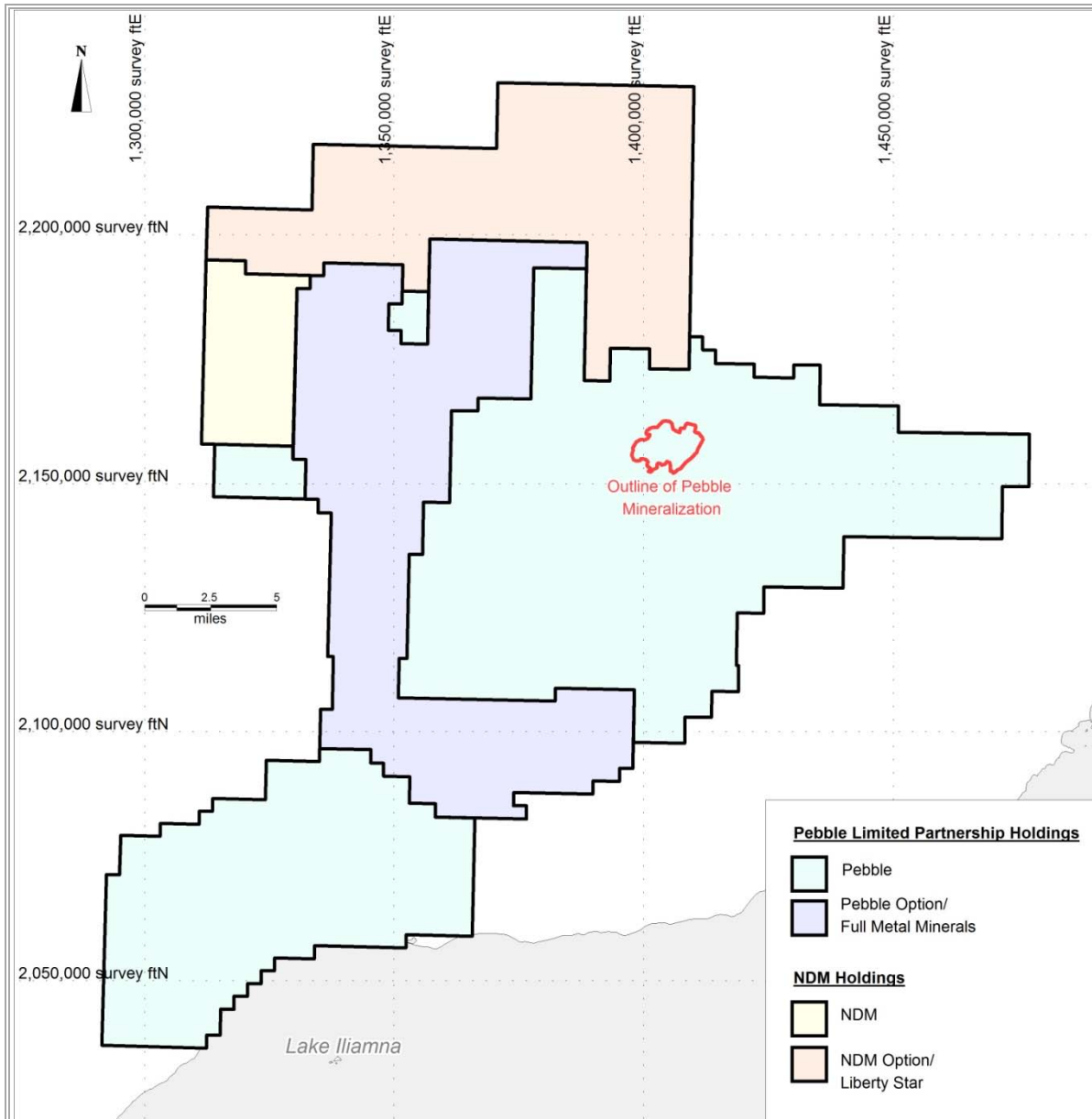
Figure 4.1.2 Location Map of the Pebble Deposit Relative to Southwest Alaska, showing Cook Inlet and Lake Iliamna



## 4.2 DESCRIPTION

Northern Dynasty holds interests in a continuous block of 3,108 mineral claims covering approximately 378,600 acres (Figure 4.2.1). The mineral claims are held through the Pebble East Claims Corporation and the Pebble West Claims Corporation, in which Northern Dynasty holds a 50% interest through a wholly-owned subsidiary by way of its interest in the Pebble Partnership. Northern Dynasty, through a wholly-owned subsidiary, also holds 95 claims covering 15,200 acres. In addition, the Pebble Partnership entered into an agreement to earn an interest in certain mineral claims from Full Metal Minerals, and Northern Dynasty has entered into an agreement to earn an interest in certain mineral claims with Liberty Star Uranium and Metals Corp.

**Figure 4.2.1 Mineral Claim Map – Pebble Project**



In total, Northern Dynasty holds indirect interests in 592 mi<sup>2</sup> (378,600 acres) of mineral claims in southwest Alaska. These include:

- 2,043 claims covering 330 mi<sup>2</sup> (210,840 acres) held by the Pebble Partnership through subsidiaries Pebble East Claims Corporation and the Pebble West Claims Corporation (including the Pebble deposit);
- 95 claims covering 24 mi<sup>2</sup> (15,200 acres) held by a wholly owned subsidiary of Northern Dynasty;

- 542 claims covering 136 mi<sup>2</sup> (86,720 acres) held by Full Metal Minerals (USA) Inc., in which the Pebble Partnership may acquire; and
- 428 mineral claims covering 102.9 mi<sup>2</sup> (86,720 acres) held by Liberty Star Uranium and Metals Corp., in which Northern Dynasty has entered into an agreement to earn an interest.

The Pebble Partnership is acquiring the right to earn a 60% interest in Full Metal’s mineral claims by incurring exploration expenditures of at least \$3 million over three years, plus other considerations. The Pebble Partnership will also have the right to purchase certain claims outright.

Northern Dynasty has the right to earn a 60% interest in Liberty Star’s mineral claims by incurring exploration expenditures of \$10 million over six years.

State mineral claims in Alaska may be kept in good standing by performing annual assessment work or by paying cash in lieu of assessment work in the amount of US\$100 per 40 acre mineral claim per year, and by paying annual escalating state rentals. All of the claims come due annually on August 31. However, credit for excess work can be banked, to a maximum of five years, and can be applied as necessary to continue to hold the claims in good standing. The Pebble claims have a variable amount of work credit available that can be applied in this way. Annual assessment work obligations for the Pebble property total some US\$947,000 and annual state rentals for 2010 are US\$627,808.

The boundaries of the claims have not been surveyed.

The details of the mineral claims are provided in Table 4.2.1.

**Table 4.2.1 Pebble Mineral Claims**

ADL Number	Claim Name	ADL Number	Claim Name
516769 - 516770	Sill 5951 - Sill 5952	566327 - 566332	Pebble Beach 2136 - Pebble Beach 2141
516779 - 516780	Sill 6051 - Sill 6052	566367 - 566373	Pebble Beach 2236 - Pebble Beach 2242
516789 - 516790	Sill 6151 - Sill 6152	566407 - 566413	Pebble Beach 2336 - Pebble Beach 2342
516797 - 516802	Sill 6247 - Sill 6252	566447 - 566453	Pebble Beach 2436 - Pebble Beach 2442
516806 - 516812	Pebble Beach 5448 - Pebble Beach 5454	566487 - 566492	Pebble Beach 2536 - Pebble Beach 2541
516813 - 516819	Pebble Beach 5548 - Pebble Beach 5554	566527 - 566532	Pebble Beach 2636 - Pebble Beach 2641
516820 - 516823	Pebble Beach 5651 - Pebble Beach 5654	566567 - 566572	Pebble Beach 2736 - Pebble Beach 2741
516824 - 516827	Pebble Beach 5751 - Pebble Beach 5754	566607 - 566610	Pebble Beach 3138 - Pebble Beach 3141
516828 - 516830	Pebble Beach 5852 - Pebble Beach 5854	566637 - 566640	Pebble Beach 2938 - Pebble Beach 2941
516831 - 516833	Pebble Beach 5952 - Pebble Beach 5954	566247 - 566252	Pebble Beach 1936 - Pebble Beach 1941
516834 - 516836	Pebble Beach 6052 - Pebble Beach 6054	566287 - 566292	Pebble Beach 2036 - Pebble Beach 2041
516837 - 516838	Pebble Beach 6153 - Pebble Beach 6154	566655 - 566660	Pebble Beach 2836 - Pebble Beach 2841
516839 - 516841	Pebble Beach 4651 - Pebble Beach 4653	566697 - 566701	Pebble Beach 3238 - Pebble Beach 3242
516842 - 516844	Pebble Beach 4751 - Pebble Beach 4753	566737 - 566740	Pebble Beach 3038 - Pebble Beach 3041
516845 - 516847	Pebble Beach 4851 - Pebble Beach 4853	566751 - 566754	Pebble Beach 3252 - Pebble Beach 3255
516848 - 516850	Pebble Beach 4951 - Pebble Beach 4953	566767 - 566771	Pebble Beach 3338 - Pebble Beach 3342
516851 - 516856	Pebble Beach 5048 - Pebble Beach 5053	566781 - 566784	Pebble Beach 3352 - Pebble Beach 3355
516857 - 516862	Pebble Beach 5148 - Pebble Beach 5153	566793 - 566796	Pebble Beach 3438 - Pebble Beach 3441
516863 - 516868	Pebble Beach 5248 - Pebble Beach 5253	566797 - 566802	Pebble Beach 3446 - Pebble Beach 3451
516869 - 516874	Pebble Beach 5348 - Pebble Beach 5353	566811 - 566814	Pebble Beach 3538 - Pebble Beach 3541
516879 - 516880	Sill 6351 - Sill 6352	566815 - 566820	Pebble Beach 3546 - Pebble Beach 3551
516888 - 516889	Sill 6451 - Sill 6452	566829 - 566832	Pebble Beach 3638 - Pebble Beach 3641

*Table continues...*

...Table 4.2.1 (Cont'd)

ADL Number	Claim Name
516948 - 516950	Pebble Beach 3850 - Pebble Beach 3852
516951 - 516953	Pebble Beach 3950 - Pebble Beach 3952
516954 - 516956	Pebble Beach 4050 - Pebble Beach 4052
516957 - 516959	Pebble Beach 4150 - Pebble Beach 4152
516960 - 516964	Pebble Beach 4250 - Pebble Beach 4254
516965 - 516969	Pebble Beach 4350 - Pebble Beach 4354
516970 - 516972	Pebble Beach 4451 - Pebble Beach 4453
516973 - 516975	Pebble Beach 4551 - Pebble Beach 4553
524511 - 524512	Sill 5543 - Sill 5544
524515 - 524516	Sill 5643 - Sill 5644
524519 - 524520	Sill 5743 - Sill 5744
524523 - 524524	Sill 5843 - Sill 5844
524527 - 524528	Sill 5943 - Sill 5944
524531 - 524532	Sill 6043 - Sill 6044
524535 - 524536	Sill 6143 - Sill 6144
524539 - 524542	Sill 6243 - Sill 6246
524543 - 524544	Sill 6343 - Sill 6344
524550 - 524551	Sill 6443 - Sill 6444
524557 - 524558	Sill 6543 - Sill 6544
524568 - 524569	Sill 6643 - Sill 6644
524579 - 524580	Sill 6743 - Sill 6744
524595 - 524596	Sill 6843 - Sill 6844
524611 - 524612	Sill 6943 - Sill 6944
524630 - 524631	Sill 7043 - Sill 7044
524649 - 524650	Sill 7143 - Sill 7144
524668 - 524669	Sill 7243 - Sill 7244
524684 - 524685	Sill 7343 - Sill 7344
524698 - 524699	Sill 7443 - Sill 7444
524712 - 524717	Sill 7543 - Sill 7548
524748 - 524751	Pebble Beach 3452 - Pebble Beach 3455
524752 - 524755	Pebble Beach 3552 - Pebble Beach 3555
524756 - 524759	Pebble Beach 3652 - Pebble Beach 3655
524760 - 524763	Pebble Beach 3752 - Pebble Beach 3755
524764 - 524765	Pebble Beach 3848 - Pebble Beach 3849
524766 - 524768	Pebble Beach 3853 - Pebble Beach 3855
524769 - 524770	Pebble Beach 3948 - Pebble Beach 3949
524771 - 524773	Pebble Beach 3953 - Pebble Beach 3955
524774 - 524775	Pebble Beach 4048 - Pebble Beach 4049
524776 - 524778	Pebble Beach 4053 - Pebble Beach 4055
524779 - 524780	Pebble Beach 4148 - Pebble Beach 4149
524781 - 524783	Pebble Beach 4153 - Pebble Beach 4155
524784 - 524785	Pebble Beach 4248 - Pebble Beach 4249
524786	Pebble Beach 4255
524787 - 524788	Pebble Beach 4348 - Pebble Beach 4349
524789	Pebble Beach 4355
524790 - 524792	Pebble Beach 4448 - Pebble Beach 4450
524793 - 524794	Pebble Beach 4454 - Pebble Beach 4455
524795 - 524797	Pebble Beach 4548 - Pebble Beach 4550
524798 - 524799	Pebble Beach 4554 - Pebble Beach 4555
524800 - 524802	Pebble Beach 4648 - Pebble Beach 4650
524803 - 524804	Pebble Beach 4654 - Pebble Beach 4655

ADL Number	Claim Name
566833 - 566838	Pebble Beach 3646 - Pebble Beach 3651
566847 - 566850	Pebble Beach 3738 - Pebble Beach 3741
566851 - 566856	Pebble Beach 3746 - Pebble Beach 3751
566865 - 566868	Pebble Beach 3838 - Pebble Beach 3841
566877 - 566880	Pebble Beach 3938 - Pebble Beach 3941
566889 - 566892	Pebble Beach 4038 - Pebble Beach 4041
566901 - 566904	Pebble Beach 4138 - Pebble Beach 4141
566905 - 566910	Pebble Beach 4238 - Pebble Beach 4243
566911 - 566916	Pebble Beach 4338 - Pebble Beach 4343
566917 - 566922	Pebble Beach 4438 - Pebble Beach 4443
566923 - 566928	Pebble Beach 4538 - Pebble Beach 4543
566929 - 566932	Pebble Beach 4638 - Pebble Beach 4641
566933 - 566936	Pebble Beach 4738 - Pebble Beach 4741
566937 - 566940	Pebble Beach 4838 - Pebble Beach 4841
566941 - 566944	Pebble Beach 4938 - Pebble Beach 4941
566945 - 566948	Pebble Beach 5038 - Pebble Beach 5041
566949 - 566952	Pebble Beach 5138 - Pebble Beach 5141
566953 - 566956	Pebble Beach 5238 - Pebble Beach 5241
566957 - 566960	Pebble Beach 5338 - Pebble Beach 5341
566961 - 566964	Pebble Beach 5438 - Pebble Beach 5441
566965 - 566968	Pebble Beach 5538 - Pebble Beach 5541
566969 - 566972	Pebble Beach 5638 - Pebble Beach 5641
566973 - 566976	Pebble Beach 5738 - Pebble Beach 5741
566977 - 566980	Pebble Beach 5838 - Pebble Beach 5841
566981 - 566984	Pebble Beach 5938 - Pebble Beach 5941
566985 - 566990	Pebble Beach 6038 - Pebble Beach 6043
566991 - 566996	Pebble Beach 6138 - Pebble Beach 6143
566997 - 567006	Pebble Beach 6238 - Pebble Beach 6247
567007 - 567016	Pebble Beach 6338 - Pebble Beach 6347
567017 - 567026	Pebble Beach 6438 - Pebble Beach 6447
567035 - 567036	Pebble Beach 6546 - Pebble Beach 6547
567045 - 567055	Pebble Beach 6646 - Pebble Beach 6656
567064 - 567069	Pebble Beach 6746 - Pebble Beach 6751
567083 - 567088	Pebble Beach 6846 - Pebble Beach 6851
567102 - 567107	Pebble Beach 6946 - Pebble Beach 6951
567841 - 567845	Sill 5343 - Sill 5347
567855 - 567860	Sill 5443 - Sill 5448
567869 - 567873	Sill 5545 - Sill 5549
567881 - 567886	Sill 5645 - Sill 5650
567893 - 567898	Sill 5745 - Sill 5750
567905 - 567911	Sill 5845 - Sill 5851
567917 - 567922	Sill 5945 - Sill 5950
567923	Sill 5953
567927 - 567932	Sill 6045 - Sill 6050
567933	Sill 6053
567937 - 567942	Sill 6145 - Sill 6150
567943 - 567944	Sill 6153 - Sill 6154
567947 - 567949	Sill 6253 - Sill 6255
567951 - 567956	Sill 6345 - Sill 6350
567957 - 567960	Sill 6353 - Sill 6356
567961 - 567966	Sill 6445 - Sill 6450

Table continues...

...Table 4.2.1 (Cont'd)

ADL Number	Claim Name
524805 - 524807	Pebble Beach 4748 - Pebble Beach 4750
524808 - 524809	Pebble Beach 4754 - Pebble Beach 4755
524810 - 524812	Pebble Beach 4848 - Pebble Beach 4850
524813 - 524814	Pebble Beach 4854 - Pebble Beach 4855
524815 - 524817	Pebble Beach 4948 - Pebble Beach 4950
524818 - 524819	Pebble Beach 4954 - Pebble Beach 4955
524820 - 524821	Pebble Beach 5054 - Pebble Beach 5055
524822 - 524823	Pebble Beach 5154 - Pebble Beach 5155
524824 - 524825	Pebble Beach 5254 - Pebble Beach 5255
524826 - 524827	Pebble Beach 5354 - Pebble Beach 5355
524828	Pebble Beach 5455
524829 - 524831	Pebble Beach 5648 - Pebble Beach 5650
524832 - 524834	Pebble Beach 5748 - Pebble Beach 5750
524835 - 524838	Pebble Beach 5848 - Pebble Beach 5851
524839 - 524842	Pebble Beach 5948 - Pebble Beach 5951
524843 - 524846	Pebble Beach 6048 - Pebble Beach 6051
524847 - 524850	Pebble Beach 6148 - Pebble Beach 6151
524851 - 524857	Pebble Beach 6248 - Pebble Beach 6254
524858 - 524864	Pebble Beach 6348 - Pebble Beach 6354
525849	Pebble Beach 6152
531355 - 531358	Pebble Beach 3642 - Pebble Beach 3645
531359 - 531362	Pebble Beach 3742 - Pebble Beach 3745
531363 - 531368	Pebble Beach 3842 - Pebble Beach 3847
531369 - 531374	Pebble Beach 3942 - Pebble Beach 3947
531375 - 531380	Pebble Beach 4042 - Pebble Beach 4047
531381 - 531386	Pebble Beach 4142 - Pebble Beach 4147
531387 - 531390	Pebble Beach 4244 - Pebble Beach 4247
531391 - 531394	Pebble Beach 4344 - Pebble Beach 4347
531395 - 531398	Pebble Beach 4444 - Pebble Beach 4447
531399	Pebble Beach 4544
531400	Pebble Beach 4547
531401 - 531404	Pebble Beach 4644 - Pebble Beach 4647
531405 - 531408	Pebble Beach 4744 - Pebble Beach 4747
531409 - 531412	Pebble Beach 4844 - Pebble Beach 4847
531413 - 531416	Pebble Beach 4944 - Pebble Beach 4947
531417 - 531420	Pebble Beach 5044 - Pebble Beach 5047
531421 - 531424	Pebble Beach 5144 - Pebble Beach 5147
531425 - 531428	Pebble Beach 5244 - Pebble Beach 5247
531429 - 531432	Pebble Beach 5344 - Pebble Beach 5347
531433 - 531436	Pebble Beach 5444 - Pebble Beach 5447
531437 - 531440	Pebble Beach 5544 - Pebble Beach 5547
531441 - 531444	Pebble Beach 5644 - Pebble Beach 5647
531445 - 531448	Pebble Beach 5744 - Pebble Beach 5747
531449 - 531452	Pebble Beach 5844 - Pebble Beach 5847
531453 - 531456	Pebble Beach 5944 - Pebble Beach 5947
531457 - 531460	Pebble Beach 6044 - Pebble Beach 6047
531461 - 531464	Pebble Beach 6144 - Pebble Beach 6147
531648 - 531649	Pebble Beach 4545 - Pebble Beach 4546
540399	Pebble Beach 5555
540400	Pebble Beach 5655
540401	Pebble Beach 5755

ADL Number	Claim Name
567967 - 567970	Sill 6453 - Sill 6456
567971 - 567982	Sill 6545 - Sill 6556
568175 - 568178	Sill 8345 - Sill 8348
568255 - 568256	Sill 8743 - Sill 8744
638779 - 638786	PEB 1 - PEB 8
638791 - 638802	PEB 13 - PEB 24
638807 - 638816	PEB 29 - PEB 38
638821 - 638830	PEB 43 - PEB 52
638835 - 638844	PEB 57 - PEB 66
638848 - 638858	PEB 70 - PEB 80
638862 - 638875	PEB 84 - PEB 97
638882 - 638893	PEB 104 - PEB 115
640061 - 640096	PEB N 1 - PEB N 36
642334 - 642337	PEB EB A1 - PEB EB A4
642338 - 642411	PEB EB 1 - PEB EB 74
642412 - 642450	PEB WB 1 - PEB WB 39
643892 - 643898	PEB SE A1 - PEB SE A7
643899 - 643930	PEB SE 1 - PEB SE 32
643931 - 643934	PEB NW A1 - PEB NW A4
643935 - 643966	PEB NW 1 - PEB NW 32
644196 - 644224	PEB SE 33 - PEB SE 61
644225 - 644230	PEB SE A8 - PEB SE A13
644231 - 644251	PEB EB 75 - PEB EB 95
644252 - 644255	PEB EB A5 - PEB EB A8
644256 - 644279	PEB WB 40 - PEB WB 63
644284 - 644303	SP 173 - SP 192
644312 - 644315	SP 201 - SP 204
644318 - 644321	SP 207 - SP 210
644322	SP 216
644323 - 644330	SP 225 - SP 232
644331 - 644335	SP 235 - SP 239
644336	SP 245
644733	South Pebble 234
644734 - 644738	South Pebble 240 - South Pebble 244
645612 - 645662	SP 322 - SP 372
646604 - 646605	Pebble Beach 5942 - Pebble Beach 5943
646606 - 646617	PEB K 1 - PEB K 12
648906 - 648909	PEB WB 64 - PEB WB 67
668740	PEBA 113
668741 - 669053	KAS 1 - KAS 313
669054 - 669068	KAS 318 - KAS 332
669069 - 669140	KAS 334 - KAS 405
<b>Pebble Option/Full Metal Minerals</b>	
ADL Number	Claim Name
552871 - 552902	South Pebble 113 - South Pebble 144
552909 - 552916	South Pebble 151 - South Pebble 158
552931 - 553019	KAK 1 - KAK 89
641977 - 641983	South Pebble 21 - South Pebble 27
641985 - 641991	South Pebble 29 - South Pebble 35
641998 - 642068	South Pebble 42 - South Pebble 112

Table continues...



...Table 4.2.1 (Cont'd)

ADL Number	Claim Name
540402	Pebble Beach 5855
540403	Pebble Beach 5955
540404	Pebble Beach 6055
540405	Pebble Beach 6155
540406	Pebble Beach 6255
540407	Pebble Beach 6355
540408 - 540415	Pebble Beach 6448 - Pebble Beach 6455
540416 - 540423	Pebble Beach 6548 - Pebble Beach 6555
540424 - 540429	Sill 7643 - Sill 7648
540430 - 540435	Sill 7743 - Sill 7748
540436 - 540441	Sill 7843 - Sill 7848
540442 - 540447	Sill 7943 - Sill 7948
540448 - 540453	Sill 8043 - Sill 8048
540454 - 540459	Sill 8143 - Sill 8148
540460 - 540465	Sill 8243 - Sill 8248
540466 - 540467	Sill 8343 - Sill 8344
540468 - 540469	Sill 8443 - Sill 8444
540470 - 540471	Sill 8543 - Sill 8544
540472 - 540473	Sill 8643 - Sill 8644
541245 - 541252	PB 113 - PB 120
542561	Pebble Beach 4856
542562	Pebble Beach 4956
542563	Pebble Beach 5056
542564	Pebble Beach 5156
542565	Pebble Beach 5256
542566	Pebble Beach 5356
542567	Pebble Beach 5456
542568	Pebble Beach 5556
542569	Pebble Beach 5656
542570	Pebble Beach 5756
542571	Pebble Beach 5856
542572	Pebble Beach 5956
542573	Pebble Beach 6056
542574	Pebble Beach 6156
542575	Pebble Beach 6256
542576	Pebble Beach 6356
542577	Pebble Beach 6456
542578	Pebble Beach 6556
542579 - 542580	Pebble Beach 4642 - Pebble Beach 4643
542581 - 542582	Pebble Beach 4742 - Pebble Beach 4743
542583 - 542584	Pebble Beach 4842 - Pebble Beach 4843
542585 - 542586	Pebble Beach 4942 - Pebble Beach 4943
542587 - 542588	Pebble Beach 5042 - Pebble Beach 5043
542589 - 542590	Pebble Beach 5142 - Pebble Beach 5143
542591 - 542592	Pebble Beach 5242 - Pebble Beach 5243
542593 - 542594	Pebble Beach 5342 - Pebble Beach 5343
542595 - 542596	Pebble Beach 5442 - Pebble Beach 5443
542597 - 542598	Pebble Beach 5542 - Pebble Beach 5543
542599 - 542600	Pebble Beach 5642 - Pebble Beach 5643
542601 - 542602	Pebble Beach 5742 - Pebble Beach 5743
542603 - 542604	Pebble Beach 5842 - Pebble Beach 5843

ADL Number	Claim Name
644304 - 644311	SP 193 - SP 200
644316 - 644317	SP 205 - SP 206
644365 - 644366	SP 274 - SP 275
644371 - 644385	SP 280 - SP 294
644386 - 644415	KAK 90 - KAK 119
644421 - 644426	KAK 125 - KAK 130
644467 - 644483	KAK 171 - KAK 187
644881 - 644912	KAK 188 - KAK 219
645600 - 645611	SP 310 - SP 321
649664 - 649770	KAK 220 - KAK 326
657890 - 657966	KAK 327 - KAK 403
663828 - 663831	KAK 136A - KAK 139A
663832 - 663835	KAK 144A - KAK 147A
663836 - 663848	KAK 158A - KAK 170A
<b>NDM</b>	
ADL Number	Claim Name
642753 - 642770	BC 265 - BC 282
642775 - 642781	BC 287 - BC 293
642786 - 642792	BC 298 - BC 304
642797 - 642803	BC 309 - BC 315
642808 - 642814	BC 320 - BC 326
642819 - 642825	BC 331 - BC 337
642832 - 642838	BC 344 - BC 350
642848 - 642854	BC 360 - BC 366
642867 - 642873	BC 379 - BC 385
642886 - 642892	BC 398 - BC 404
642905 - 642911	BC 417 - BC 423
642924 - 642931	BC 436 - BC 443
642944 - 642946	BC 456 - BC 458
<b>NDM Option/Liberty Star</b>	
ADL Number	Claim Name
642826 - 642827	BC 338 - BC 339
642839 - 642843	BC 351 - BC 355
642855 - 642862	BC 367 - BC 374
642874 - 642881	BC 386 - BC 393
642893 - 642900	BC 405 - BC 412
642912 - 642919	BC 424 - BC 431
642932 - 642939	BC 444 - BC 451
642947 - 642960	BC 459 - BC 472
642964 - 642983	BC 476 - BC 495
642987 - 643006	BC 499 - BC 518
643008 - 643044	BC 520 - BC 556
643046 - 643082	BC 558 - BC 594
643090 - 643118	BC 602 - BC 630
643126 - 643154	BC 638 - BC 666
643162 - 643190	BC 674 - BC 702
643198 - 643226	BC 710 - BC 738
643228 - 643256	BC 740 - BC 768
643272 - 643286	BC 784 - BC 798

Table continues...

...Table 4.2.1 (Cont'd)

ADL Number	Claim Name	ADL Number	Claim Name
552917 - 552930	South Pebble 159 - South Pebble 172	643298 - 643311	BC 810 - BC 823
553427 - 553538	PEBA 1 - PEBA 112	643323 - 643335	BC 835 - BC 847
553539 - 553577	PEBB 1 - PEBB 39	643339 - 643353	BC 851 - BC 865
553578 - 553587	PEBE 1 - PEBE 10	643357 - 643371	BC 869 - BC 883
553588 - 553614	PEBF 1 - PEBF 27	643432 - 643453	BC 1001 - BC 1022
553615 - 553616	SILL 6155 - SILL 6156	649923 - 649932	BC 1171 - BC 1180
553617	SILL 6256	649939 - 649940	BC 1187 - BC 1188
		649948 - 649949	BC 1196 - BC 1197

### 4.3 SURFACE RIGHTS

There are no surface rights currently held by Northern Dynasty or other parties. Surface rights are acquired from the state government once areas required for mine development have been determined and permits awarded.

### 4.4 ENVIRONMENTAL LIABILITIES

As Pebble is a project at which no prior development or mining has been done, there are no existing environmental liabilities.

### 4.5 PERMITS

Permits necessary for the upcoming field programs are applied for each year. No permits for mining and other activities envisaged in this Preliminary Assessment are currently held as these are likely to be modified based on the results of final feasibility studies and the environmental assessment process. Additional information on permitting is provided in Chapter 18.4.

### 4.6 OWNERSHIP HISTORY

The following summary of historical property agreements and the current operating agreements is taken from Rebagliati, 2010.

*“In October 2001, Northern Dynasty acquired, through its Alaskan subsidiary, a two-part Pebble Property purchase option previously secured by Hunter Dickinson Group Inc. (HDGI) from an Alaska subsidiary of Teck Cominco Limited, now Teck Resources Limited (Teck). In particular HDGI assigned this two part option (the Teck Option) as to 80% to Northern Dynasty while retaining 20% thereof. The first part of the Teck Option permitted Northern Dynasty to purchase (through its Alaskan subsidiary) 80% of the previously drilled portions of the Pebble Property on which the majority of the then known copper mineralization occurred (the “Resource Lands Option”). Northern Dynasty could exercise the Resource Lands Option through the payment of cash and shares aggregating US\$10 million prior to November 30, 2004. The second part of the Teck Option permitted Northern Dynasty to earn a 50% interest in the*

exploration area outside of the Resource Lands (the "Exploration Lands Option"). Northern Dynasty could exercise the Explorations Lands Option by doing some 18,288 m (60,000 ft) of exploration drilling by November 30, 2004, which it completed on time. The HDGI assignment of the Teck Option also allowed Northern Dynasty to purchase the other 20% of the Teck Option retained by HDGI for its fair value.

In November 2004, Northern Dynasty exercised the Resource Lands Option and acquired 80% of the Resource Lands. In February 2005, Teck elected to sell its residual 50% interest in the Exploration Lands to Northern Dynasty for US\$4 million. Teck still retains a 4% pre-payback advance net profits royalty interest (after debt service) and 5% after-payback net profits interest royalty in any mine production from the Exploration Lands portion of the Pebble property.

In June 2006, Northern Dynasty acquired, through its Alaska subsidiaries, the remaining HDGI 20% interest in the Resource Lands and Exploration Lands by acquiring HDGI from its shareholders and through its various subsidiaries had thereby acquired an aggregate 100% interest in the Pebble Property, subject only to the Teck net-profits royalties on the Exploration Lands described above. At that time, Northern Dynasty operated the Pebble Property through a general Alaskan partnership with one of its subsidiaries.

In July 2007, Northern Dynasty converted the aforementioned general partnership into a limited partnership, the Pebble Limited Partnership (the "Pebble Partnership"), so that an indirect wholly-owned subsidiary of Anglo American plc (Anglo) could subscribe for 50% of the Pebble Partnership's equity effective July 31, 2007. Each of Northern Dynasty and Anglo effectively has equal control and management rights in the Pebble Partnership (and its general partner, Pebble Mines Corp.) through respective wholly-owned affiliates. The Pebble Partnership's assets include the shares of two Alaska subsidiaries which hold registered title to the claims comprising the Pebble Property. To maintain its 50% interest in the Pebble Partnership, Anglo is required to make staged cash investments into the Pebble Partnership aggregating US\$1.425 billion as described below. Anglo's staged investment requirements include an initial minimum expenditure of US\$125 million. This investment funded expenditures on the project approved by the Board of the general partner (Pebble Mines Corp.), with the goal of producing a prefeasibility study. After approval of a prefeasibility study, Anglo is required, in order to retain its 50% interest in the Pebble Partnership, to elect to commit to further expenditures which bring its total investment to at least US\$450 million which amount is to be expended towards producing a final feasibility study and in related activities, the completion of which is expected to take the Pebble Partnership to a production decision. The final feasibility study may require more than the cumulative US\$450 million of expenditures. Upon an affirmative decision by the Pebble Partnership to develop a mine, Anglo is required to elect to commit to the remainder of the total investment of US\$1.425 billion in order to retain its interest in the Pebble Partnership. Following completion of the US\$1.425 billion expenditure, any further expenditure will be funded by Anglo and Northern Dynasty on a 50:50 basis (subject to dilution for non-contribution). If the feasibility study is completed after 2011, Anglo's overall funding requirement increases from US\$1.425 billion to US\$1.5 billion. The Pebble Partnership agreement provides for equal project control rights via equal director representation rights on the Board of Pebble Mines Corp. with no operator's fees payable to either party. The legal agreements forming the Pebble Partnership are filed on [www.SEDAR.com](http://www.SEDAR.com)."

On June 29, 2010, Northern Dynasty entered into a letter agreement with Liberty Star and its subsidiary, Big Chunk Corp. (together “LS”), pursuant to which LS sold 23.8 mi<sup>2</sup> (61.5 km<sup>2</sup>), the “Purchased Claims,” to a US subsidiary of Northern Dynasty in consideration for both a \$1,000,000 cash payment and a secured convertible loan from Northern Dynasty in the amount of \$3,000,000 (the “Loan”). The Loan is secured by LS’s Big Chunk and Bonanza Hills properties in Alaska and accrues interest at 10% per annum.

In addition, subject to negotiating and signing a definitive earn-in option and joint venture agreement, Northern Dynasty can earn a 60% interest in LS’s remaining Big Chunk and Bonanza Hills projects in Alaska by spending \$10,000,000 on those properties over six years. The Loan from Northern Dynasty may be applied as part of the earn-in requirements, at Northern Dynasty’s discretion.

On September 10, 2010, the Pebble Partnership entered into a letter agreement (the “Full Metal Agreement”) with Full Metal Minerals Corp. and Full Metal Minerals (USA) Inc. (together, “FMM”), pursuant to which the Pebble Partnership can earn a 60% interest in FMM’s South Pebble Claims (the “FMM Properties”), upon completion of incurring exploration expenditures of at least \$3,000,000 over a period of three years. The venture between FMM and the Pebble Partnership will be in the form of a limited liability company (LLC).

Under the Agreement, the Pebble Partnership was required to complete a Z-Axis Tipper Electromagnetic Technique (ZTEM) airborne survey over the Properties, before January 1, 2011. This survey has been completed. In addition, from the date of signature of the Agreement until either completion of the earn-in or termination of the Agreement, the Pebble Partnership will make an annual payment of \$50,000 to FMM. The \$50,000 payment for 2010 has been made. For the duration of the earn-in period and the joint venture, the Pebble Partnership will have an option, under certain conditions, to select and purchase claims that form part of the Properties (the “Purchased Claims”) at a price of \$25/acre.

For the duration of the earn-in period, the Pebble Partnership will be the operator of the FMM Properties.

The FMM Properties total 542 claims, covering approximately 135 mi<sup>2</sup>, located west and north west of the ground held 100% by the Pebble Partnership.

## 5.0 ACCESSIBILITY, CLIMATE, LOCAL RESOURCES, INFRASTRUCTURE AND PHYSIOGRAPHY

---

### 5.1 ACCESSIBILITY

---

The Pebble property is located in a remote area of southwest Alaska. Access to the property is typically via air travel from the city of Anchorage, which is situated at the northeastern end of Cook Inlet and is connected to the national road network via Interstate Highway 1 through Canada to the USA. Anchorage is serviced daily by several regularly scheduled flights to major airport hubs in the USA.

From Anchorage, there are regular flights to Iliamna through Iliamna Air Taxi. Charter flights may also be arranged from Anchorage. From Iliamna, access to the Pebble property is by helicopter.

### 5.2 CLIMATE

---

The climate of the Iliamna area is similar to that of Anchorage where, the mean daily maximum temperature in July is 63°F (17°C) and the mean daily minimum temperature in January is 9°F (-13°C). Average annual precipitation is 27 inches (689 mm), most of which is rainfall from June through August.

The climate, while periodically harsh, is sufficiently moderate to allow a well-planned mineral exploration program to be conducted year-round (Rebagliati, C.M., and Haslinger, R.J., 2003).

### 5.3 INFRASTRUCTURE

---

There is a modern airfield at Iliamna, with two paved 4,920 ft airstrips that services the communities of Iliamna, Newhalen, and Nondalton. The runways are suitable for DC-6 and Hercules cargo aircraft, and small commercial jet aircraft.

There are paved roads that connect the airport to Iliamna and Newhalen, and a partly paved, partly gravel road that extends to the Newhalen River crossing near Nondalton. The Pebble property is currently not connected to any of these local communities by road; however, a road is being planned as part of the Pebble Project design.

The three communities of Iliamna, Newhalen and Nondalton are linked together by a maintained road; however, there is no direct access road that connects these communities to the coast on Cook Inlet. From the coast, at Williamsport, on Iniskin Bay, there is a 30-km state maintained road that comes to the east side of Iliamna Lake where watercraft and transport barges may be used to access Iliamna.

During the summer, supplies are barged up the Kvichak River, approximately 70 km southwest of Iliamna, from Kvichak Bay on the North Pacific Ocean. Bulk fuel and freight can therefore be transported to Iliamna Lake for surrounding communities located on and around the lake.

A small run-of-river hydroelectric installation on the nearby Tazamina River provides power for the three communities in the summer months.

## 5.4 LOCAL RESOURCES

---

Iliamna and surrounding communities have a combined population of approximately 439 persons. As such, there is limited commercial infrastructure locally except that which services a seasonal sports fishing and hunting industry

The property is located approximately 60 miles west from tidewater in Cook Inlet and access to the Pacific Ocean.

## 5.5 PHYSIOGRAPHY

---

The Pebble property is situated at approximately 1,000 feet (ft) above mean sea level (amsl) (305 m) in an area described as sub-arctic tundra. It is characterized by gently rolling hills, and an absence of permafrost.

From Rebagliati, C.M. and Haslinger J.M., 2003:

*“The Pebble property lies 80.5 km (50 mi) west of the Alaska Range in the Nushagak–Big River Hills, an area of rolling hills and low mountains separated by wide, shallow valleys blanketed with glacial deposits that contain numerous small, shallow lakes and are cut by several major meandering streams. The elevation ranges from 250 m (820 ft) amsl to 841 m (2,758 ft) amsl at Kaskanak Peak, the highest point on the property.*

*Tundra plant communities (mixtures of shrub and herbaceous plants) cover the project area. Willow is common only along streams and sparse patches of dense alder are confined to better drained areas where coarse soils have developed. Poorly drained regions underlain by fine soils support dwarf birch and grasses (Detterman and Reed, 1973).”*

## 6.0 HISTORY

In the mid 1980s, Cominco Alaska began reconnaissance exploration in the Pebble region and in 1984 discovered the Sharp Mountain gold prospect near the southern margin of the current Pebble property. Gold occurs in drusy quartz veins of probable Tertiary age that cut Cretaceous rocks near the peak of Sharp Mountain (anonymous Cominco Alaska report, 1984). Grab samples of veins in talus ranged from 1.5 g/t Au to 9.32 oz/ton Au and 3.0 oz/ton Ag. No record of further work is available, but the same or similar quartz veins were encountered in 2004 during property surface mapping conducted by Northern Dynasty. Most of these trend north-south and dip steeply.

In 1987, examination and sampling of several prominent limonitic and hematitic alteration zones yielded anomalous gold concentrations from the Sill prospect (recognized as a precious-metal, epithermal-vein occurrence) and the Pebble discovery outcrop (of uncertain affinity). The 1988 exploration program included 24 diamond-drill holes at the Sill epithermal, gold prospect (Table 6.1.1) and soil sampling, geological mapping, and two diamond drill holes at the Pebble target (Table 6.1.2). Drilling at the Sill prospect intercepted mineralization with gold grades that justified more work, but the initial Pebble drill holes yielded only modest encouragement. In 1989, an expanded soil-sampling program, an induced polarization (IP) survey, and nine diamond-drill holes were completed at the Pebble target, and 15 diamond drill holes were completed at the Sill prospect and three diamond drill holes elsewhere on the property. Although limited in scope, the IP survey at Pebble displayed response characteristics of a large porphyry-copper system. Subsequent drilling by Cominco Ltd. (Teck) intercepted significant intervals of porphyry-style gold, copper, and molybdenum mineralization, validating this interpretation.

**Table 6.1.1 Cominco Drilling on Sill Prospect to End of 1997**

Year and Company	No. Drill Holes	Feet	Metres
1988 Cominco	24	7,048	2,148
1989 Cominco	15	3,398	1,036
<b>Total</b>	<b>39</b>	<b>10,446</b>	<b>3,184</b>

**Table 6.1.2 Cominco Drilling on Pebble Deposit to the End of 1997**

Year and Company	No. Drill Holes	Feet	Metres
1988 Cominco	2	554	169
1989 Cominco	9	3,131	954
1990 Cominco	25	10,021	3,054
1991 Cominco	48	28,129	8,574
1992 Cominco	14	6,609	2,014
1997 Cominco	20	14,696	4,479
<b>Total</b>	<b>118</b>	<b>63,140</b>	<b>19,245</b>

When it became apparent that a significant copper-gold-porphyry deposit had been discovered at Pebble, exploration was accelerated. In 1990 and 1991, 25 and 48 diamond-drill holes were completed, respectively. In 1991, baseline environmental and engineering studies were initiated and weather stations were established. A preliminary economic evaluation was undertaken by Cominco in 1991 and was updated in 1992 on the basis of 14 new diamond-drill holes. In 1993, an IP survey and a four-hole, diamond-drill program was completed at a target 6 km to the south of the Pebble deposit. In 1997, Cominco performed an IP survey, geochemical sampling, and geological mapping, and diamond-drilled 20 holes into and near the Pebble deposit (Table 6.1.3).

**Table 6.1.3 Total Cominco Drilling on Pebble Property to the End of 1997**

Year and Company	No. Drill Holes	Feet	Metres
1988 Cominco	26	7,602	2,317
1989 Cominco	27	7,422	2,262
1990 Cominco	25	10,021	3,054
1991 Cominco	48	28,129	8,574
1992 Cominco	14	6,609	2,014
1993 Cominco	4	1,263	385
1997 Cominco	20	14,696	4,479
<b>Total</b>	<b>164</b>	<b>75,741</b>	<b>23,086</b>

Since 2001, Northern Dynasty, and subsequently the Pebble Partnership, has staked additional claims, conducted further geochemical and geophysical surveys, completed 867,456.2 ft of drilling, and a significant amount of engineering, baseline environmental studies and stakeholder engagement.

## 6.1 HISTORICAL RESOURCE ESTIMATES

Cominco conducted several resource estimates on the Pebble deposit during the 1990s, employing block models estimated with either kriging or inverse distance (ID) weighting. The cut-off grade used was 0.3% CuEQ based on metal prices of US\$1.00/lb of copper and US\$375/oz of gold. These estimates are summarized in Table 6.1.1.

**Table 6.1.1 Cominco Resource Estimates**

Year	Tons (million)	Cu (%)	Au (oz/ton)
1990	200	0.35	0.01
1991	500	0.35	0.01
1992	460	0.40	0.01
2000	1,000	0.30	0.01

Historical estimates should not be relied upon for investment purposes.



## 7.0 GEOLOGICAL SETTING

---

### 7.1 REGIONAL GEOLOGY

---

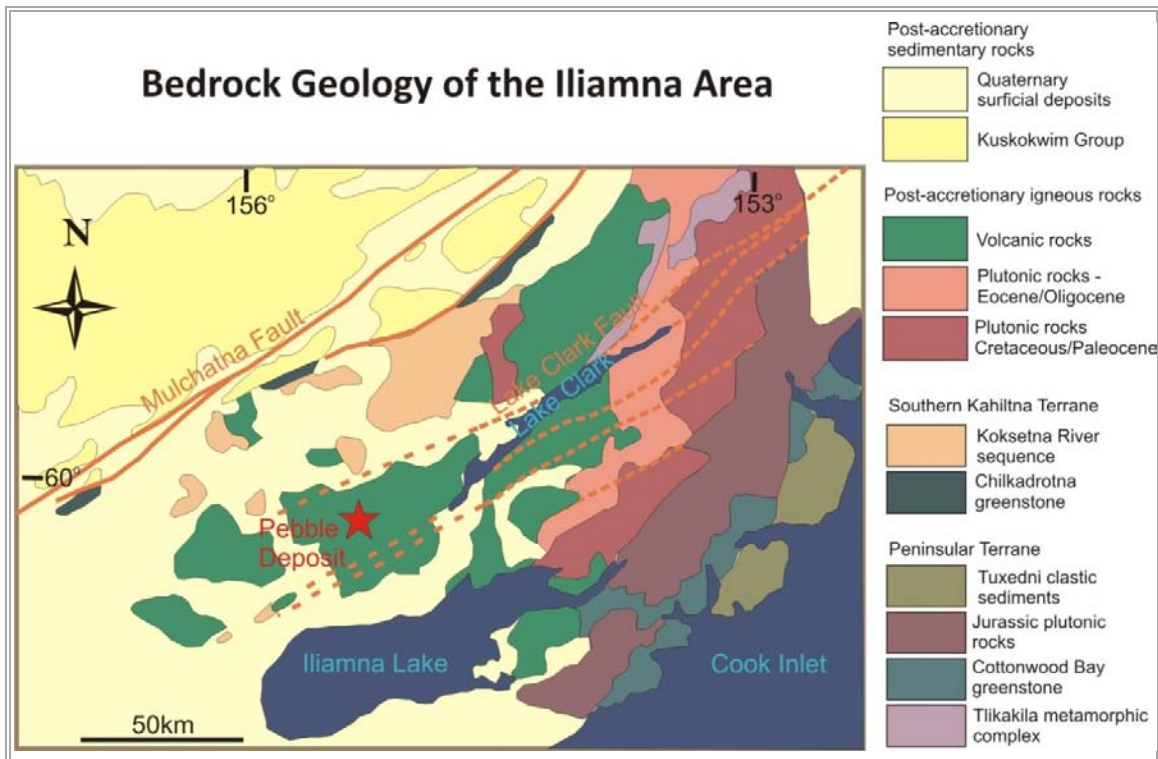
The regional geology of the Lower Western Cook Inlet area, where the Pebble deposit is located, is dominated by Late Jurassic to Early Cretaceous basinal turbidites of the Kahiltna terrane (Jones et al., 1987; Wallace et al., 1984). These clastic sediments were probably eroded from the Late Triassic and younger mafic to intermediate volcanics, chert, shale and limestone to westward succeeding Peninsular terrane; part of the more regionally extensive Talkeetna super-terrane. They were deposited in a narrow basin aligned with the subduction suture zone against the continental (Alaska) side of the Wrangellia volcanic arc terrane. The Wrangellia and Kahiltna terranes docked to Alaska in the Cretaceous Period.

The regional setting of the Pebble district has been discussed by Plafker and Berg (1994), Bouley et al. (1995), Goldfarb (1997), Young et al. (1997), and their contained references. Southwest Alaska is composed of an assemblage of northeast-trending tectonostratigraphic terranes that amalgamated southward in response to long-lived, northeast- to northwest-directed subduction, beginning in the Late Paleozoic (Goldfarb, 1997). The Pebble district is located within the Kahiltna Terrane, just northwest of its contact with the Peninsular Terrane to the southeast (Figure 7.1.1).

The nature of the contact between the Kahiltna and Peninsular terranes in the vicinity of the Pebble deposit is not well-defined. Although the contact plausibly involved major, arc-parallel or arc-oblique structural contacts, the precise location of such inferred structures and the periods in which they were tectonically active has not been determined.

The Kahiltna Terrane is one of several extensional forearc basins filled by Jurassic to Cretaceous flysch (Plafker et al., 1989), which closed in the middle Mesozoic due to arc-normal convergence and approach of the Wrangellia terrane from the south (Nokleberg et al., 1994). It may have formed by closure of the Kahiltna and Peninsular basins (Plafker et al., 1989), possibly along an early manifestation of the Lake Clark fault zone (Figure 7.1.1). The southern part of the Kahiltna Terrane is dominated by basinal turbidities of Late Jurassic to Early Cretaceous age derived from an intermediate volcanic source, and lesser sequences of Late Triassic and younger basalt, andesite, tuff, chert, shale and limestone (Jones et al., 1987; Wallace, 1984). The Peninsular Terrane contains Permian limestone, Upper Triassic limestone, chert, tuff and agglomerate (which may correlate with similar rocks in the Kahiltna terrane), Early to Middle Jurassic volcanic and intrusive rocks, and Middle Jurassic to Cretaceous clastic rocks.

Figure 7.1.1 Regional Solid Geology of the Western Southwest Cook Inlet Area



The Pebble property has been interpreted to lie between terminal strands of the inactive Lake Clark fault zone, a dextral, transtensional splay off the arc-parallel Castle Mountain-Bruin Bay fault zone, where displacement dissipates within a westward escape structure (Figure 7.1.1) (Goodman, 2008). These structures are inferred and their location has not been delineated; field relationships indicate that structural activity extended from prior to the formation of Pebble at about 90 Ma into at least the Eocene. Regionally, thrust faults and strong folding developed in the Cretaceous, but at Pebble deformation at this time was accommodated primarily by steep faulting.

Magmatic activity in the Kahlitna terrane in the area of the Pebble deposit occurred in several stages across a large range in age (Goldfarb, 1997; data in this report). The district was intruded at about 90 Ma (Figure 7.1.1) by the intermediate Kaskanak batholith. To the immediate east of the batholith is a suite of slightly older (mostly approximately 97 Ma), texturally and compositionally diverse stocks, dykes, sills and irregular bodies. Pebble is related temporally to the 90 Ma intrusions.

Younger intrusions in or near the district include Late Cretaceous rocks (approximately 78 Ma; Full Metal Minerals, pers. comm., 2008), and Early Paleocene (approximately 65 Ma; this report) and Eocene (approximately 46 Ma; this report), which formed during northward subduction of the Pacific plate beneath the North American plates on the modern Aleutian arc and its precursors (Goldfarb, 1997; Young et. al., 1997). Tertiary, mostly Eocene, magmatism includes abundant mafic to felsic volcanic and subvolcanic rocks, along with sedimentary and volcano-sedimentary strata.

Southwest Alaska was covered by Quaternary to Recent glaciers, and most valleys are now filled with glacial sedimentary deposits (Hamilton, 2008, and contained references).

According to Wallace et al.<sup>1</sup> (1989), the Kahiltna terrane is one of a number of regionally extensive and highly deformed Jurassic to Cretaceous basinal turbidite deposits occur along most of the inboard boundary of the Talkeetna super-terrane in southern Alaska and western Canada. Stratigraphic, sedimentological, compositional, and structural evidence suggests that the Upper Jurassic to Lower Cretaceous strata of the southern Kahiltna terrane were derived from and deposited on rocks of the adjacent Talkeetna super-terrane. Deposition of these clastic rocks apparently post-dated arc magmatism in the Talkeetna super-terrane, suggesting deposition in a basin developed on the suture between the Talkeetna super-terrane and North America.

Bouley et al., (1995) positioned the Pebble deposit close to the regionally projected boundary of the southern Kahiltna terrane and the Peninsular terrane. Tectonic activity has resulted in compressional stresses (and associated faults) related to northwest motion and subduction of the Pacific Plate under the Alaskan continent to the northwest.

The southern Kahiltna terrane is intruded by Cretaceous to Tertiary plutons, including the igneous intrusive system which hosts mineralization at Pebble.

Hart<sup>2</sup> (2010), utilizing data from PLP supplemented by new isotopic data, described hydrothermal mineralization associated with the Pebble deposit as “directly associated with three lithologically and geochemically diverse plutonic suites that intruded Jura-Cretaceous Kahiltna flysch strata over an approximately 10 Ma period in the mid-Cretaceous from 97 to 88 Ma”. Hart continued:

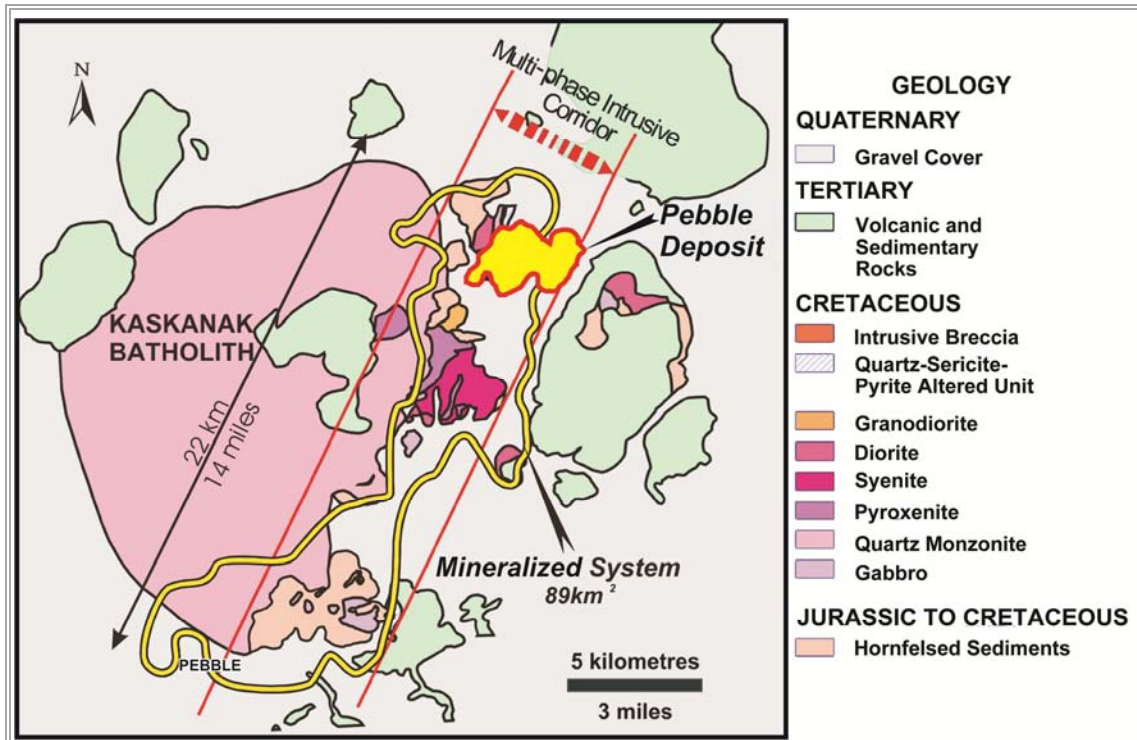
*“The oldest suite consists of intrusions of coarse-grained pyroxene gabbro, hornblende diorite sills, and granodiorite sills that are laterally extensive, up to 300 m thick, and host mineralization. U-Pb dates indicate the units are 96 Ma, or slightly older.*

*“Several alkalic units form an intrusive and breccia complex, and several smaller solitary stocks. Biotite pyroxenite forms a large, texturally-variable body with fine-grained diopsidic phases and coarse-grained phases with abundant biotite, magnetite, and apatite. Several quartz-deficient monzonitic units with K-feldspar megacrysts occur locally, and cut the mafic rocks. Intrusive breccias occur throughout the complex. The rocks are alkaline, high-K, and silica-saturated. U-Pb dates indicate intrusion at approximately 96 Ma.*

*“The youngest, most volumetrically and economically important suite is dominated by quartz-phyric hornblende granodiorite and monzodiorite, and forms the large Kaskanak batholith, as well as the four intrusions that host the Pebble West Zone, and the larger body in the centre of the East Zone. The Kaskanak has accessory magnetite and titanite, the Pebble plutons are similar, with sparse phenocrysts of equant K-feldspar. Calc-alkaline geochemistry characterizes all units. U-Pb zircon dates of 91-89 Ma and Re-Os molybdenite dates of approximately 89.5 Ma establishes a temporal relationship of these magmas with mineralization.*

*“All three plutonic suites are isotopically primitive indicating melt derivation from a youthfully-enriched lithosphere or mantle. Associated volcanic rocks are absent throughout the district, and coeval intrusions are not recognized, therefore evidence for a mid-Cretaceous volcano-plutonic arc is lacking. The alkali precursor magmas, their relationships with the calc-alkaline suites, as well as an atypical non-arc setting for Pebble, may have genetic implications for its size, enrichments in of Cu, Au and Mo, and large gold endowment.”*

Figure 7.1.2 District Geology of the Pebble Deposit Showing the Major Lithological Units and Relative Ages



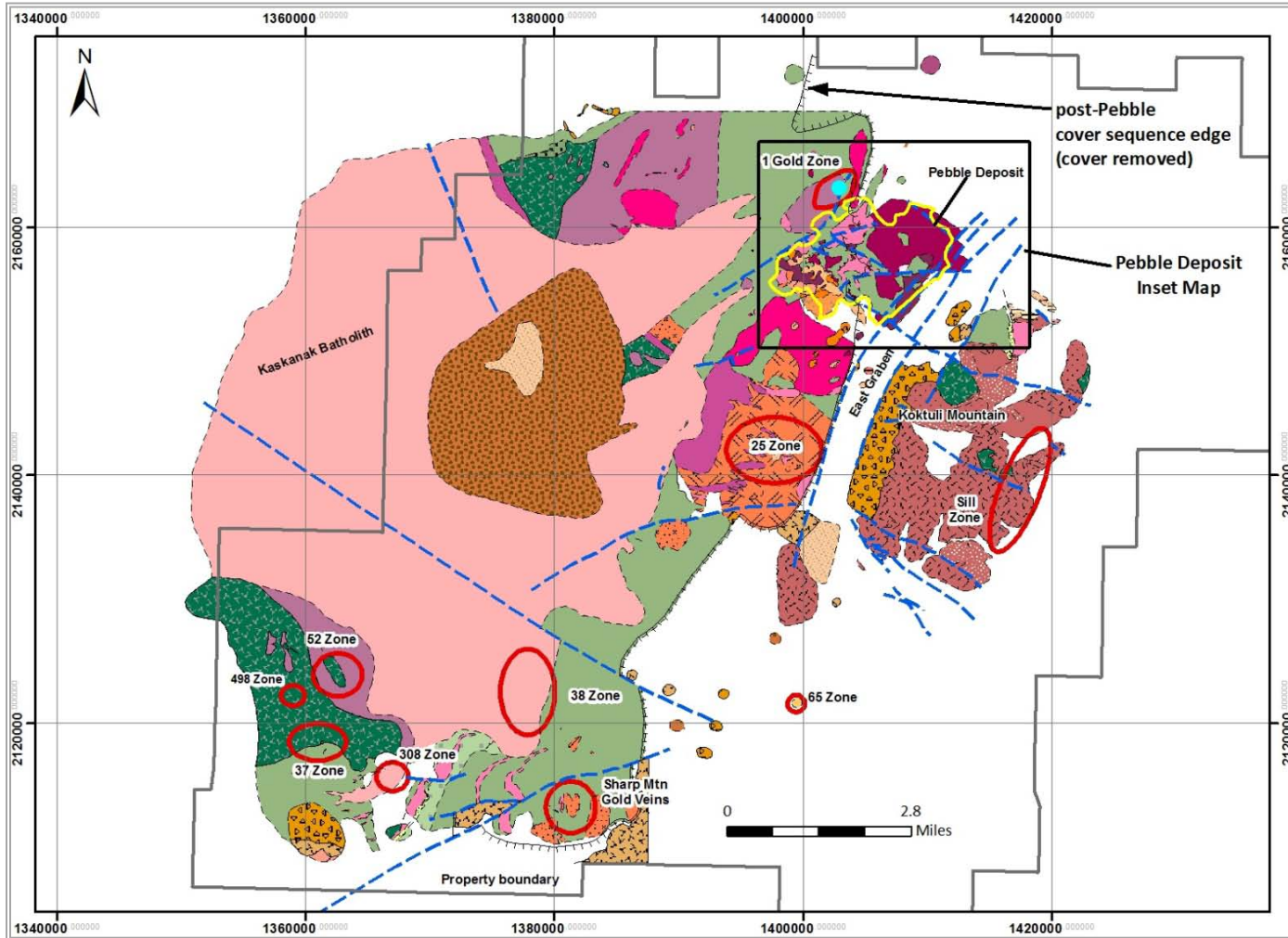
## 7.2 DEPOSIT GEOLOGY

The Pebble deposit is a very large, calc-alkalic porphyry copper-molybdenum-gold deposit. It extends from the surface in the western side, to a depth of over 5,577 ft (1,700 m) towards the eastern side, over a horizontal distance of 2.4 miles (4.0 km). It is understood almost exclusively by extensive diamond drilling. All major geological units are depicted in Figure 7.2.1.

Rock types in the Pebble deposit include the following major groups:

- pre-hydrothermal rock types formed at or before approximately 96 Ma;
- syn-hydrothermal granodiorite plutons emplaced at about 90 Ma;
- post-hydrothermal rocks which include a Late Cretaceous to Early Tertiary sedimentary and volcanic cover sequence formed, at least in part, prior to 64 Ma; and
- Eocene magmatic rocks dated at about 46 Ma.

Figure 7.2.1 Interpreted Solid Geology of the Pebble District Based on Surface Exposures and Drill Intersections



### 7.2.1 SEDIMENTARY ROCKS

The oldest rocks of the deposit are Early Jurassic to Late Cretaceous siltstone, argillite and greywacke of the Kahiltna terrane. These folded turbidite sedimentary rocks are intercalated with mafic volcanics. Near the batholith, these rocks are thermally metamorphosed to a biotite-bearing hornfels. Matrix-supported quartz-pebble conglomerate beds are very rare, less than 3 m in thickness and have only been intersected in a few drill holes at great depth. These sedimentary rock types are immature and were derived predominantly from intermediate volcanic source rocks. They are a major host to mineralization in the Pebble deposit. They are recrystallized, either as a consequence of low-grade regional metamorphism or in a wide hornfels aureole which surrounds the Kaskanak batholith. Minimum age is approximately 97 Ma, based on the isotopic ages of sills which intrude the sequence. Graded beds, load casts and other small-scale features indicate that the stratigraphic section is upright. Bedding strikes north to north-northeast and has an average dip of about 19° to the east or east-southeast.

### 7.2.2 PLUTONIC ROCKS

Diorite sills intruded the Kahiltna flysch at about 96 Ma. Diorite is an important host to mineralization in the West Zone, where it forms laterally extensive bodies from a few to greater than 100 m in thickness. Diorite has not been intersected in the East Zone. Xenoliths of diorite occur in most phases of the alkalic intrusive and breccia complex and near the margins of granodiorite plutons, but have not been observed in granodiorite sills. Diorite has a fine-grained texture of intergrown plagioclase and hornblende, locally with minor pyroxene, with minor, small, elongate phenocrysts of plagioclase.

In the deposit area, an undated gabbro intrusion might also be a plutonic equivalent of the diorite sills. Gabbro is more coarse-grained than diorite and contains a higher proportion of pyroxene, which along with plagioclase occurs as subphenocrysts in a dark, fine- to medium-grained matrix.

A monzonite intrusion and breccia complex occurs in the southern part of the West Zone. The complex comprises porphyritic, quartz-deficient, biotite monzonite to monzodiorite intrusions with a probable alkalic composition and with isotopic ages mostly around 96 Ma. Xenoliths of siltstone, wacke and diorite are common in each rock type and large rafts of diorite and granodiorite sills are surrounded by phases of the complex, which has been interpreted as a mega intrusion breccia (Rebagliati and Payne, 2005, 2006). The intrusions commonly grade into or are spatially related to breccias interpreted by earlier workers (e.g. Rebagliati and Payne, 2005) as intrusion breccias. All rock types in this suite host mineralization.

Granodiorite sills are an important host to mineralization throughout the Pebble deposit. They occur as numerous, stacked, largely bedding-parallel intrusions emplaced into the Kahiltna Flysch. They are laterally very extensive and range from a few to greater than 300 m in thickness. Granodiorite sills are thickest in the northeast part of the East Zone, and are truncated to the east by the ZG<sub>1</sub> fault. There are three main, laterally continuous sills; the upper two are progressively truncated by the paleo-erosion surface between mineralized Cretaceous rocks and the cover sequence. They have very sharp contacts with host rocks and only rarely contain xenoliths. Phenocrysts comprise up to 10% prismatic hornblende and up to 55% equant to elongate plagioclase in a fine-grained matrix of Kfeldspar, quartz, apatite, titanite and magnetite. Based upon U-Pb isotopic ages, granodiorite and diorite sills may be

coeval; neither occurs as xenoliths in the other, they both occur as large blocks in the alkalic complex in the West Zone and they have similar styles of emplacement into the Kahiltna Flysch. Granodiorite sills have been intersected in a few drill holes outside the Pebble deposit, but their broader distribution is not known.

There are five granodiorite plutons in the Pebble deposit. They are medium-grained porphyries and phenocrysts comprise 7% euhedral hornblende, 50% to 55% slightly elongated plagioclase, 1% equant K-feldspar megacrysts up 1.5 cm in size, 2% small, round, variably resorbed quartz eyes, 2% magnetite and less than 1% titanite. The matrix is fine-grained quartz, plagioclase, and K-feldspar. All U-Pb isotopic dates on zircon are about 90 Ma, which overlaps with Re-Os dates of about 89.5 Ma on molybdenite from the Pebble deposit and establishes a temporal relationship to mineralization.

Granodiorite plutons cut granodiorite and diorite sills and the alkalic monzonite-breccia complex. The East Zone stock occurs in the centre of the East Zone and is the largest body; it has minimum dimensions of 2,000 m NE-SW by 600 m E-W and is open to the south and east. Four smaller granodiorite plutons have been intersected in the West Zone. A similar body of altered but only weakly mineralized granodiorite occurs southwest of the West Zone (Rebagliati and Payne, 2005). Contacts are vertical or dip steeply outward. Wall rock xenoliths are rare and only found close to pluton contacts, and dykes and sills extend only short distances into the host rocks to the plutons.

### 7.2.3 COVER SEQUENCE

The easternmost margin of the Pebble West deposit is overlain unconformably by a cover sequence of Late Cretaceous to Early Tertiary sedimentary and volcanic rocks. This succession thickens eastward in a wedge-like fashion, completely blanketing the Pebble East Zone, and is divided into two main structural blocks by the ZG<sub>1</sub> fault. Southeast of this major northeast-trending structure, the unconformity is downthrown some 600 to 900 m, whereas further southeast the subparallel ZG<sub>2</sub> fault may downdrop the unconformity up to another 300 m; an alternative interpretation is that the contact between the cover sequence and the underlying Cretaceous rocks dips steeply to the east which would require much less offset on the ZG<sub>2</sub> fault. Accordingly, the maximum thickness of the cover sequence is approximately 600 m immediately northwest of the ZG<sub>1</sub> fault, whereas to the southeast beyond the ZG<sub>2</sub> fault the thickness can exceed 1,800 m.

Northwest of the ZG<sub>1</sub> fault the lower half of the cover sequence comprises a broadly layered sequence of clastic sedimentary rocks. However, apart from a thick basal conglomerate unit, much of the overlying sedimentary sequence is typified by complexly interlayered lenses and laterally discontinuous units of pebble conglomerate, sandstone, siltstone and mudstone. The upper half of the cover sequence consists of mostly volcanic and volcanoclastic rocks, which resemble those preserved southeast of the ZG<sub>1</sub> fault within the East Graben where rock types are dominated by volcanic flows and flow-related breccias with lesser interbeds of fine- to medium-grained clastic sedimentary rocks. On both sides of the ZG<sub>1</sub> fault much of the volcanoclastic sequence which overlies the basal sedimentary succession is basaltic to andesitic in composition, with a minor component of acid intrusive rocks (dacites, monzonites). All of these rocks are also found as narrow dykes and sills within the underlying sedimentary package.

In both structural and lithological domains, the unconformity atop the deposit is sharp and exhibits no indications of paleo-weathering effects.

#### 7.2.4 LATE MAGMATIC ROCKS

A distinct biotite-hornblende monzonite porphyry intrusion has returned two U-Pb dates on zircon between 64 and 65 Ma. The unit intrudes the Late Cretaceous to Early Tertiary cover sequence within the East Graben, where it forms at least two sheets up to 200 m thick accompanied by narrower offshoots and establishes a minimum age for at least the lower part of the cover sequence. This rock type has not been intersected in the Pebble deposit. This stage of magmatism comprises volcanic and sub-volcanic intrusive units dated at about 46 to 47 Ma. These rocks occur mostly east to southeast of the Pebble deposit on Kuktuli Mountain but proximal to the Pebble deposit have only been documented as rare rhyolite flows, dykes and breccias; most of these intersections are in the East Graben. Eocene rocks are volumetrically very minor within the Pebble resource.

#### 7.2.5 QUATERNARY GLACIAL SEDIMENTS

Unconsolidated glacial sediments, typically less than 50 m thick, cover the deposit area.

### 7.3 STRUCTURAL GEOLOGY

---

Deformation within the Pebble deposit is dominated by faulting (Figure 7.3.1 to Figure 7.3.4), which includes an early-stage of brittle-ductile deformation formed during compression and later brittle faults formed during extension. Minor folding is evident in the Kahiltna Flysch host rocks.

#### 7.3.1 FOLDING

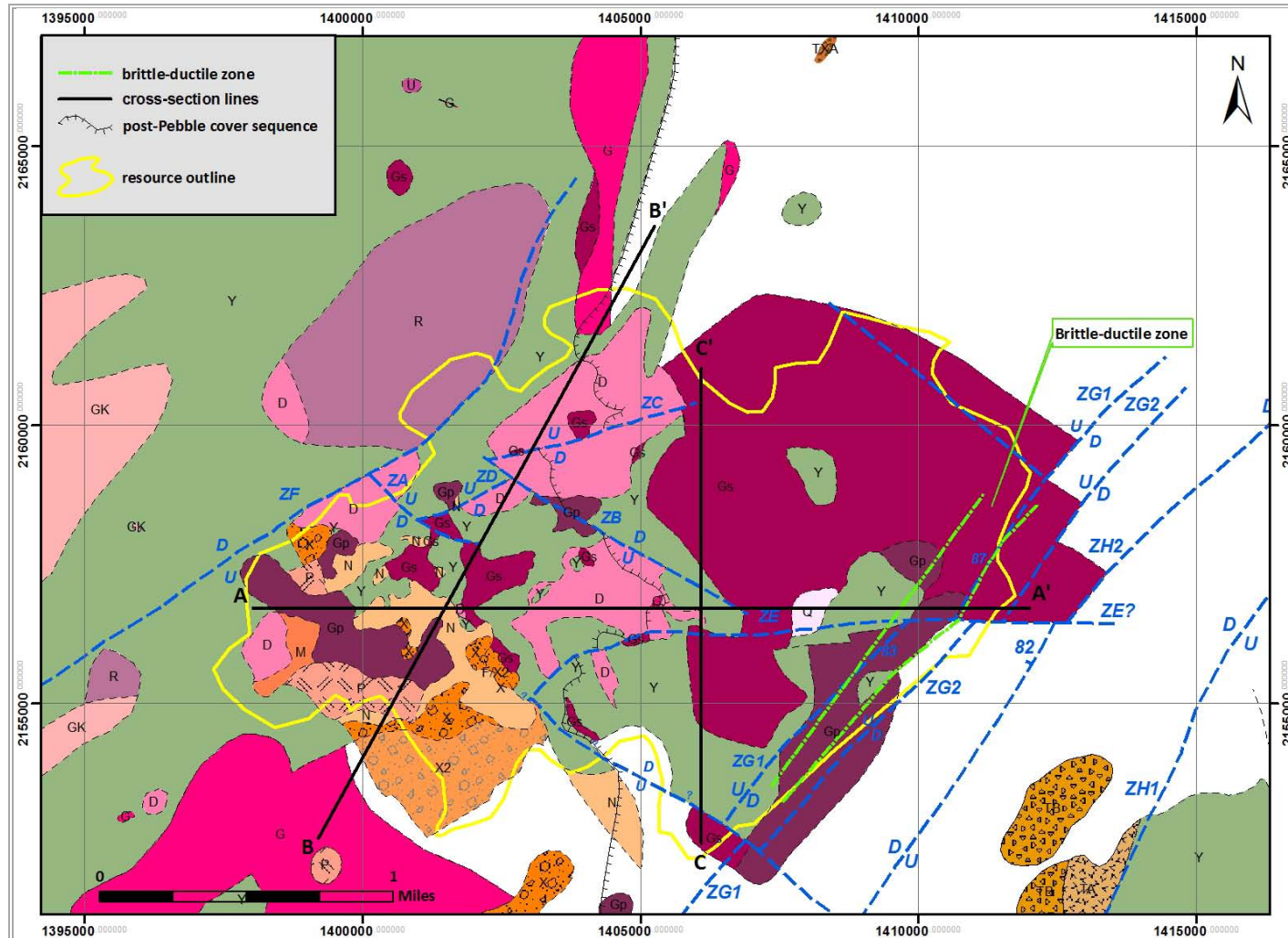
The Kahiltna Flysch has been affected by broad, open folding, which in the West Zone has been described as an 'M-shaped' fold (Rebagliati and Payne, 2005). Smaller, subsidiary warps may also be present. Fold axes plunge gently to the southeast. These folds may have influenced the highly variable thickness of diorite and granodiorite sills. Folding is either less well-developed in the East Zone or has not been recognized due to wide drill spacing. This folding occurred at an undetermined time prior to about 97 Ma.

#### 7.3.2 BRITTLE-DUCTILE DEFORMATION

A brittle-ductile fault zone defined by cataclasites and healed fault breccias was identified by drill intersections during 2008. Brittle-ductile deformation was active during formation of the Pebble deposit and controlled the flow of fluids responsible for advanced argillic alteration which produced the highest grades in the deposit. This zone occurs on the east side of the East Zone and strikes sub-parallel to, but is truncated on its east side by, the ZG1 fault, which may have later exploited or been influenced by this pre-existing structure. Brittle-ductile deformation continued, at least locally, after formation of the Pebble deposit but does not extend into the Late Cretaceous to Early Tertiary cover sequence.



**Figure 7.3.1 Interpreted Cretaceous Geology of the Pebble Deposit Showing Major Structural Features**



1056140100-REP-R0001-00

Figure 7.3.2 Geological Cross-section (A-A') Looking North\*

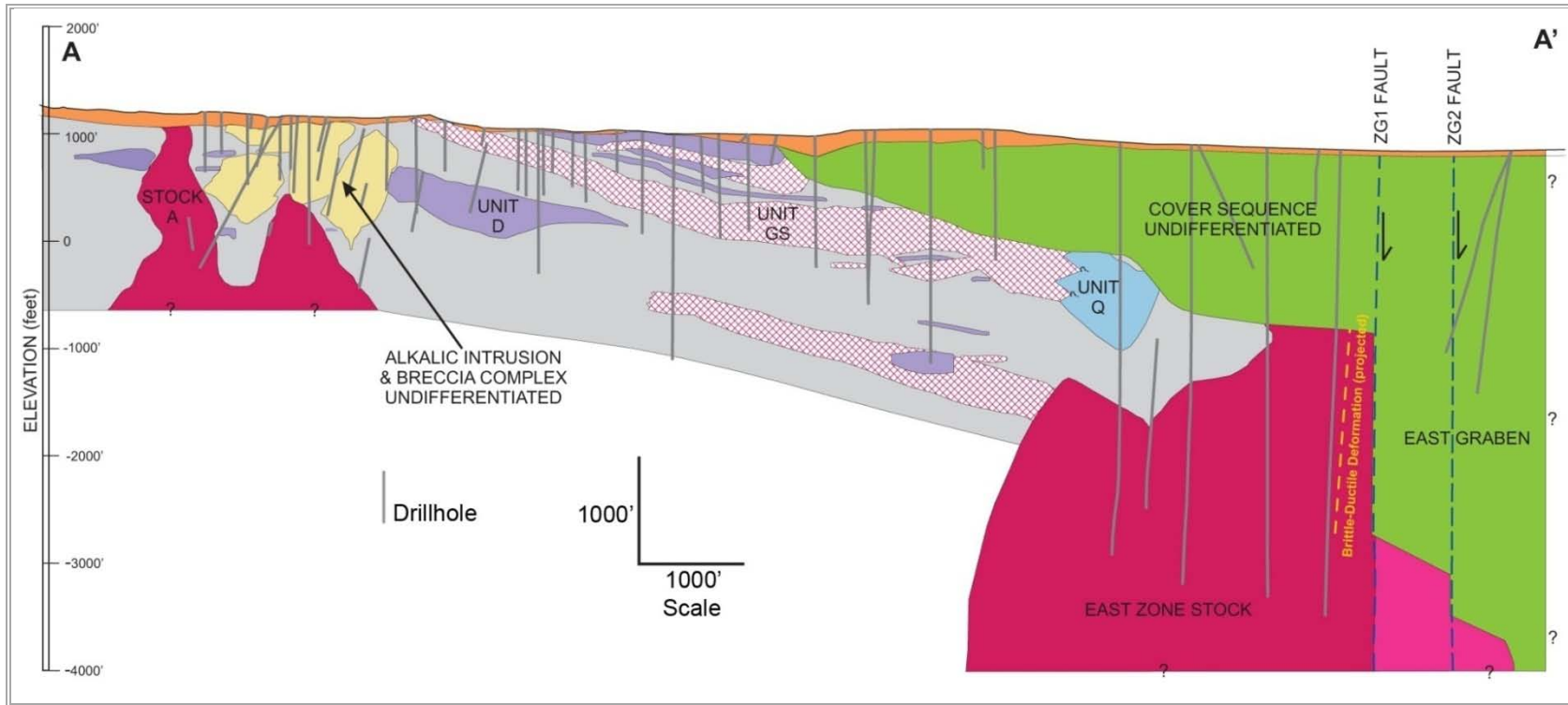
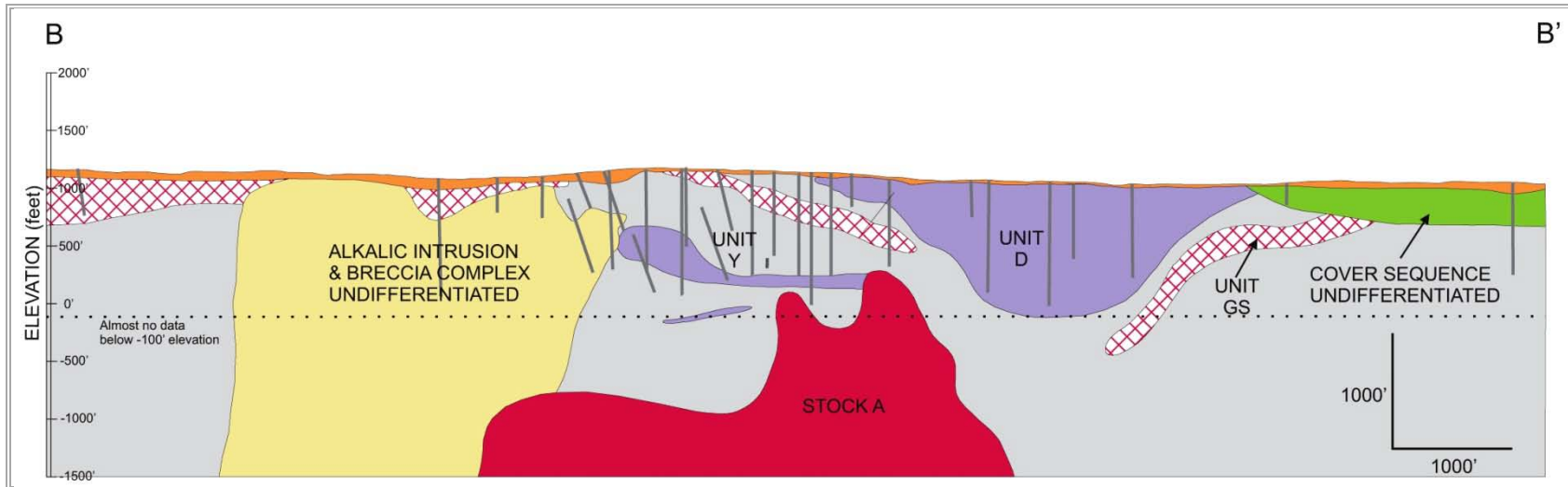
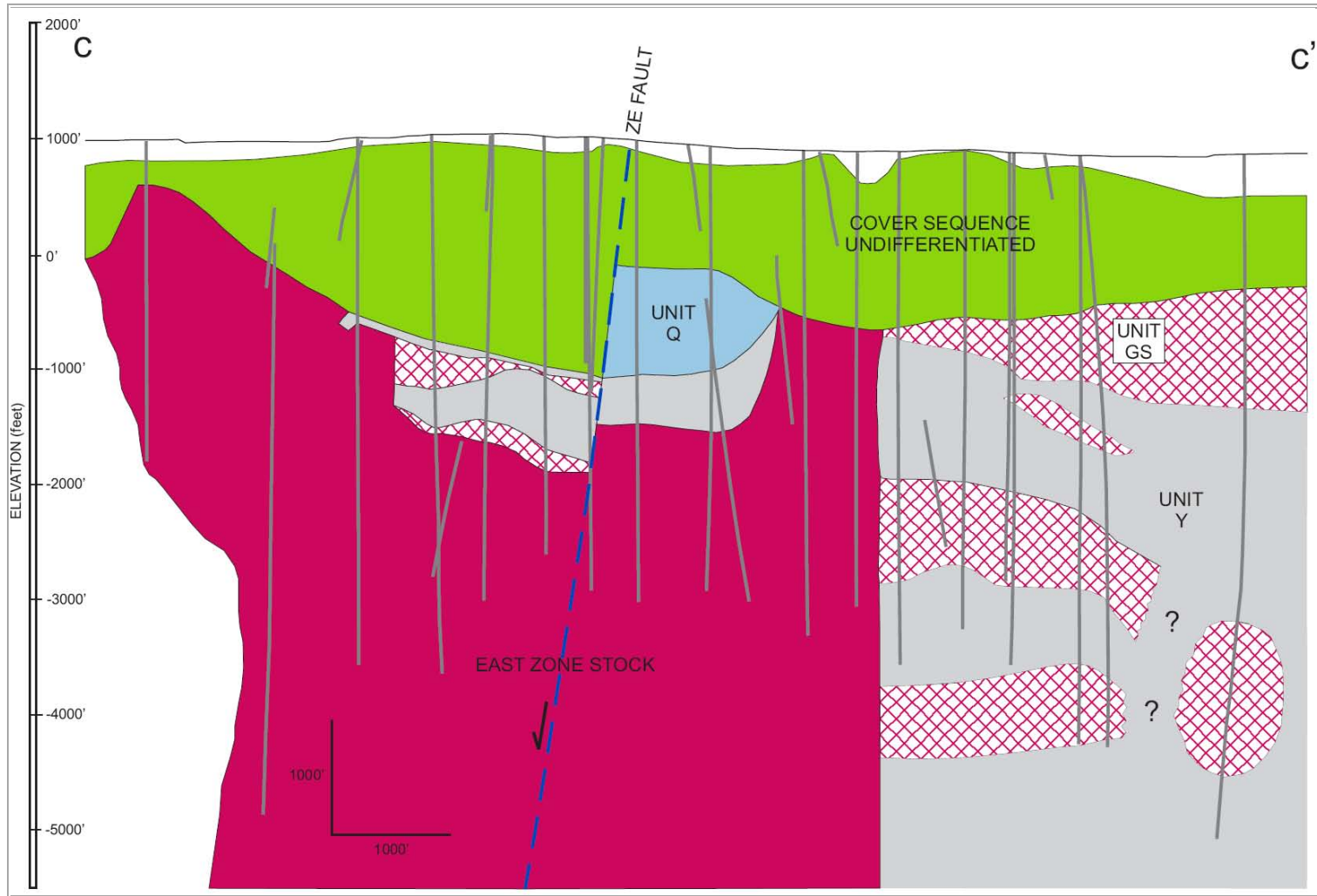


Figure 7.3.3 Geological Cross-section (B-B') through the Pebble West Zone, Looking Northwest\*



\* Dotted line shows depth limit for most drilling.

Figure 7.3.4 Geological Cross-section through the Pebble East Zone (C-C'), Looking Northwest



The zone is at least 2,300 m in length and extends to at least 1,600 m depth; it is up to 200 m in width northwest of, but is truncated and down-dropped into the East Graben by, the ZG<sub>1</sub> fault. Absolute displacement on the brittle-ductile fault is not constrained, but kinematic indicators suggest dextral-oblique movement.

### 7.3.3 BRITTLE FAULTS

The Pebble deposit is cut by a number of mostly normal, brittle faults. Brittle faults in the Pebble West Zone are coded ZA through ZF. These faults are all steeply dipping and each has normal displacement of 15 to 45 m, except for the ZA fault which has reverse movement of about 30 m. The ZF fault has 45 to 90 m of normal displacement and juxtaposes copper-gold-molybdenum mineralization in the Pebble deposit to the southeast against gabbro to the northwest, which is intensely altered by an auriferous quartz-sericite-pyrite assemblage but lacks copper-molybdenum mineralization. Normal, south-side-down movement on the east-trending ZE fault increases from less than 100 m in the West Zone to about 300 m in the East Zone.

The major extensional structure in the Pebble East Zone is the northeast-trending East Graben. On its northwest side, the graben is well-defined by the steeply southeast-dipping ZG<sub>1</sub> normal fault, which offsets the contact between the underlying Pebble deposit and the Late Cretaceous to Early Tertiary cover sequence by 600 to 900 m. The sub-parallel ZG<sub>2</sub> fault has additional normal displacement south of the ZE fault of up to 300 m, but this structure has not been conclusively intersected north of the ZE fault.

East tilting of the district by about 19° has slightly overturned the ZG<sub>1</sub> fault in the north part of the East Zone, imparting an apparent reverse displacement. The ZE fault is interpreted to cut the ZG<sub>1</sub> fault and the graben. Kahiltna Flysch and diorite sills are exposed well to the east of the deposit on Kaktuli Mountain; the ZH<sub>1</sub> and ZH<sub>2</sub> faults are interpreted on this basis as west-dipping corollaries to the ZG<sub>1</sub> and ZG<sub>2</sub> faults on the east side of the graben.

### 7.3.4 TILTING OF THE DISTRICT

Bedding in mudstones in the Late Cretaceous to Early Tertiary cover sequence demonstrates that the Pebble deposit has been tilted about 19° to 20° to the east or east-southeast. This occurred after much of the extensional faulting had taken place, but absolute timing is not known.



## 8.0 DEPOSIT TYPES

---

The Pebble deposit is classified as a copper-gold-molybdenum porphyry deposit. The principal features of porphyry copper deposits, as summarized recently by John et al., 2010, include:

- ores are defined by copper and other minerals which occur as disseminations and in veins and breccias and which are relatively evenly distributed through their host rocks;
- large tonnage amenable to bulk mining methods;
- low to moderate copper grades typically between 0.3 and 2.0%;
- a genetic relationship to porphyritic intrusions of intermediate composition which typically formed in convergent margin tectonic settings;
- a metal assemblage dominated by various combinations of copper, gold, molybdenum and silver but commonly with other associated metals of low concentration; and,
- a spatial association with other styles of intrusion-related mineralization which include skarns, polymetallic replacements and veins, distal disseminated gold-silver deposits, and intermediate to high-sulphidation epithermal deposits.

These characteristics correspond closely to the principal features of the Pebble deposit as described in Sections 7.0 and 9.0 of this report. This report focuses exclusively on the Pebble porphyry deposit; other centres of intrusion-related skarn, vein and porphyry style mineralization have, however, been encountered elsewhere on the Pebble property but have not been the subject detailed exploration or delineation.

Pebble has one of the largest metal endowments of any gold-bearing porphyry deposit currently known. Comparison of the current Pebble resource to other major gold-bearing porphyry deposits shows that it ranks at or near the top in terms of both contained copper (Figure 8.1.1) and gold (Figure 8.1.2). The basis of this estimation of metal endowment in the Pebble deposit is fully described in Section 17.0 of this report.

Figure 8.1.1 Pebble Deposit Rank by Contained Copper

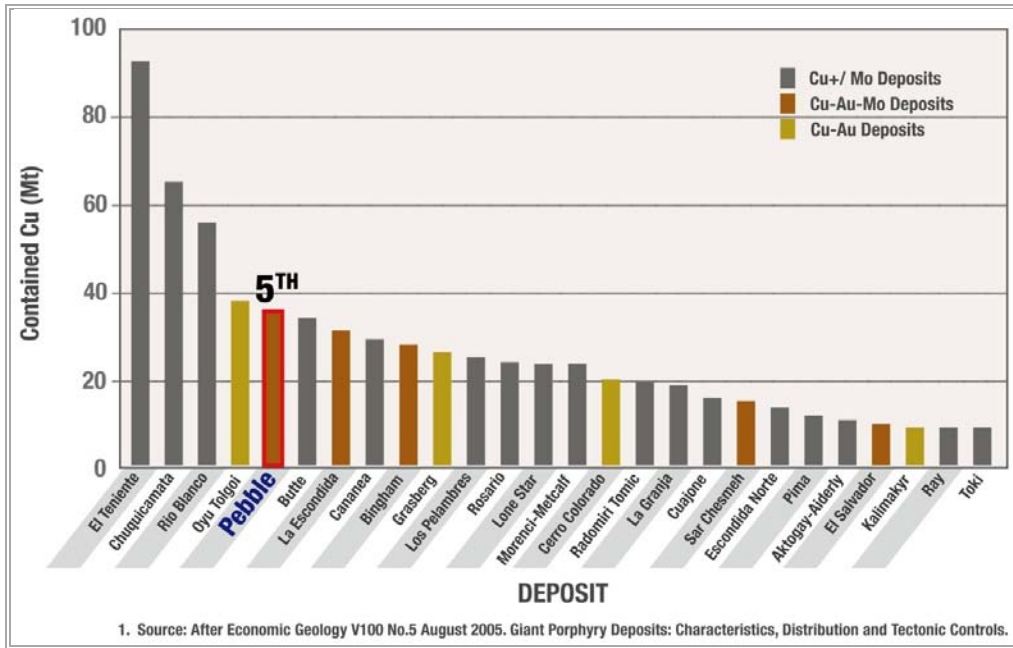
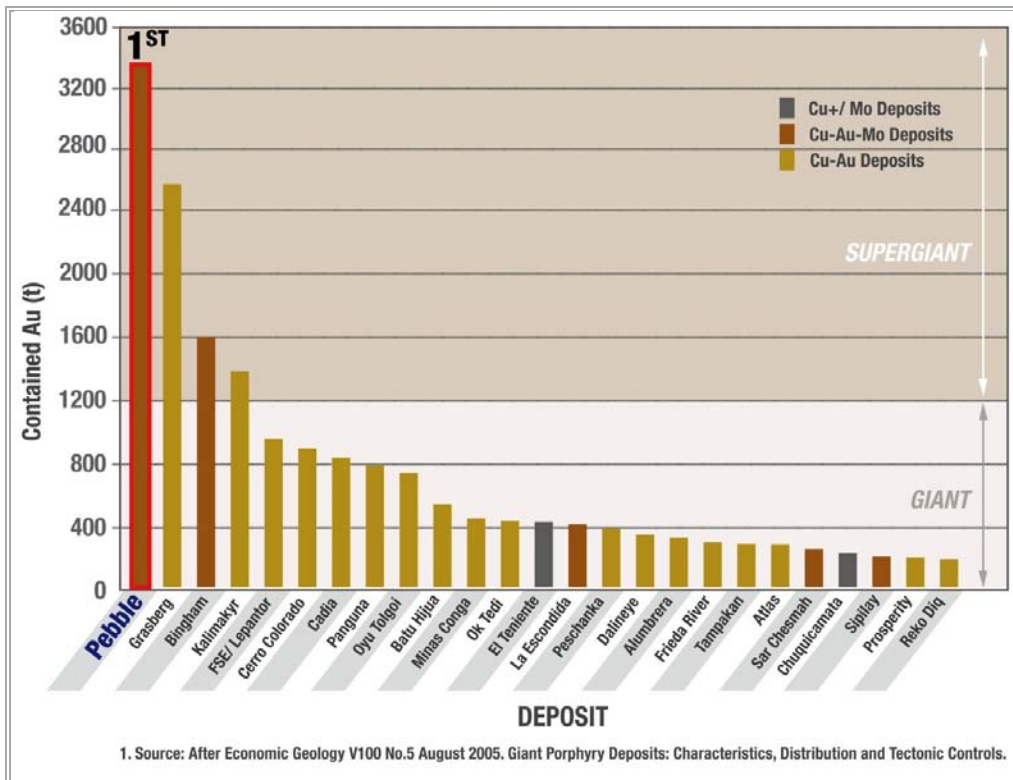


Figure 8.1.2 Pebble Deposit Rank by Contained Gold





## 9.0 MINERALIZATION

---

This section describes alteration assemblages, vein types, and mineralization styles in the Pebble deposit. Other areas which host Eocene or mid-Cretaceous mineralization, but which are located outside the Pebble deposit, are also summarized.

### 9.1 HYDROTHERMAL ALTERATION

---

In most parts of the Pebble deposit, the principal control on grade distribution is alteration and associated veins, with only minor host rock influence. This section describes these alteration assemblages, along with their zoning patterns and relationship to grade.

#### 9.1.1 SUMMARY OF MAJOR ALTERATION TYPES

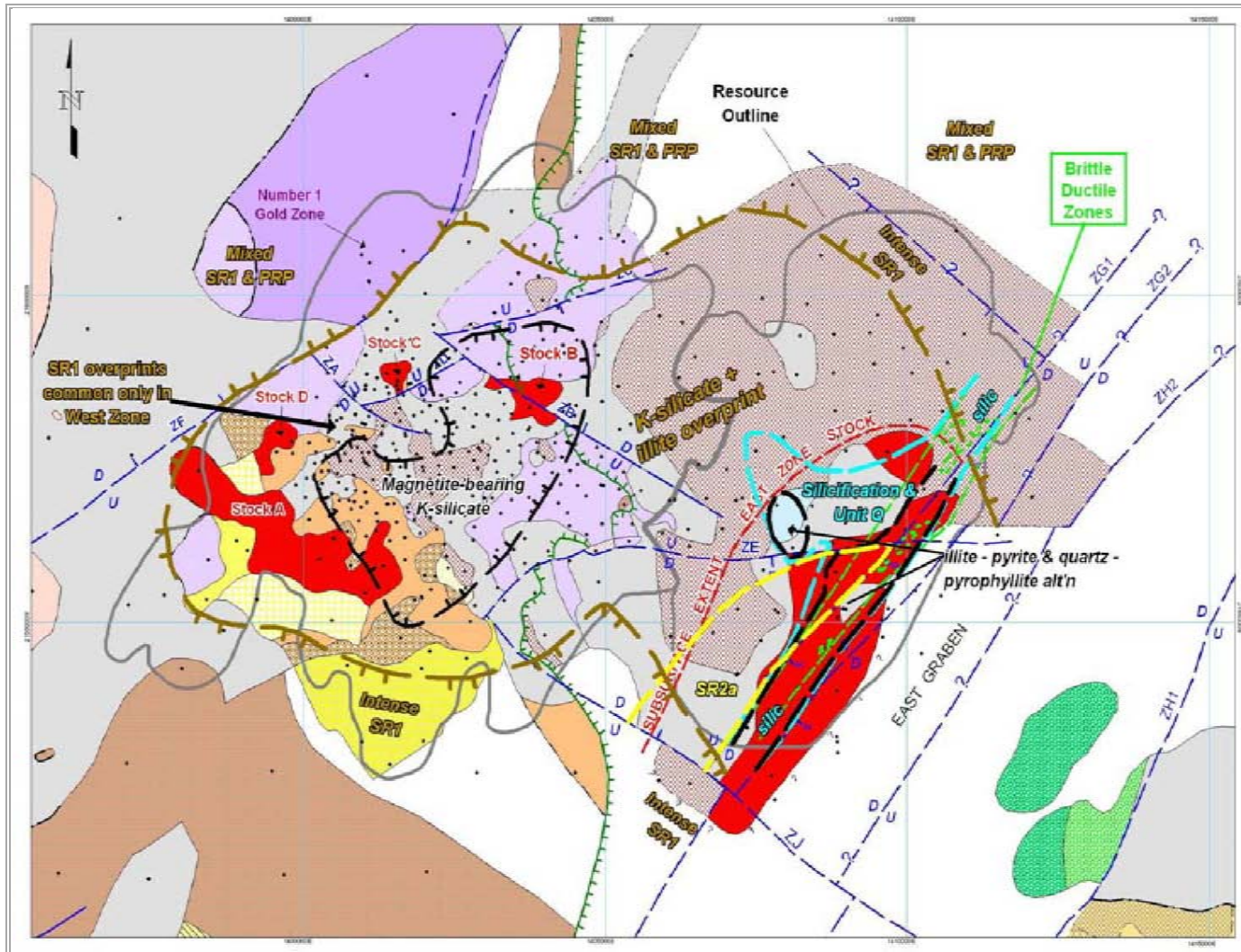
The distribution of alteration assemblages in the Pebble deposit is shown in Figure 9.1.1. The major alteration types comprise:

- Pre-hydrothermal hornfels (logging code HRF);
- Deep sodic-calcic alteration (NCA);
- Early K-silicate alteration which comprises K-feldspar-rich (KS<sub>1</sub>), biotite-rich (KS<sub>2</sub>) and magnetite-bearing (KS<sub>2m</sub>) subtypes;
- Peripheral propylitic alteration (PRP);
- An illite overprint (SR<sub>2b</sub>) on early K-silicate alteration;
- Younger advanced argillic alteration (SR<sub>2a</sub> and SR<sub>2c</sub>) and associated silicification;
- Young, peripheral quartz-sericite-pyrite alteration (SR<sub>1</sub>); and
- Post-Pebble, low-temperature propylitic and clay alteration related to young faults which cut the deposit (no code).

#### HORNFELS (HRF)

The Kahiltna Flysch was converted to massive, dark green hornfels prior to the onset of main-stage hydrothermal activity at Pebble. Early type EB veins (see below) may have formed during hornfels. Hornfels is a passive host to mineralization. Later mineralizing fluids flowed through abundant fractures but inter-fracture domains had low permeability and, as a consequence, hornfels commonly has lower overall grade than other rock types in the deposit.

Figure 9.1.1 Distribution of Alteration Types in the Pebble Deposit



## K-SILICATE ALTERATION

Most copper-gold-molybdenum mineralization was introduced during early K-silicate alteration. The broader K-silicate assemblage comprises K-feldspar dominated, biotite-rich and magnetite-bearing subtypes. Current interpretation is that all K-silicate subtypes are approximately coeval and the variants reflect, at least in part, host rock composition and proximity to hydrothermal centres.

### *K-Feldspar Dominated K-Silicate Subtype (KS1)*

This is the main alteration type, which along with biotite-rich KS<sub>2</sub> introduced most copper-gold-molybdenum mineralization. It is the dominant mineralized alteration within granodiorite intrusions. The assemblage is K-feldspar, quartz, highly variable but mostly minor biotite, trace to minor apatite, ankerite and rutile, and sulphides. Anhydrite has only been observed in a very few samples, mostly from great depth. Magnetite is a minor, erratically but widely distributed component of this alteration in the West Zone, but is absent from all but a few deep samples from the East Zone. Sulphide minerals are dominated by sub-equal pyrite and chalcopyrite, accompanied by lesser, disseminated molybdenite. Locally, chalcopyrite co-precipitated with bornite (which is paragenetically distinct from the replacement bornite described below). Early K-silicate alteration is related to vein types A, B, and C (see below).

### *Biotite-Rich K-Silicate Subtype (KS2)*

This alteration is most strongly developed in sedimentary host rocks (Units Y and W), the older alkalic suite (Units N, M, P, X<sub>1</sub>) with exception of Units F and X<sub>2</sub>, and diorite sills (Unit D). The intensity of biotite development, particularly relative to K-feldspar, corresponds generally with the amount of original iron and magnesium in the protolith. The assemblage is similar to KS<sub>1</sub> except for differences in relative mineral proportions. This alteration is associated with vein types B and C. It is possible that the KS<sub>2</sub> subtype is a slightly older stage of K-silicate alteration than the KS<sub>1</sub> subtype.

### *Magnetite-Bearing K-Silicate Subtype (KS2m)*

This alteration is nearly identical to normal biotite-rich KS<sub>2</sub> alteration, except that it also contains magnetite as disseminations and in type M veins (see below). It occurs only in the West Zone where it is found mostly within or proximal to iron-rich diorite of Unit D and, to a lesser extent, in other rock types.

## ILLITE ALTERATION (SR2B)

This alteration occurs throughout most of the Pebble deposit but is strongest within granodiorite plutons, particularly the East Zone stock. The intensity and distribution of SR<sub>2b</sub> alteration corresponds closely to that of K-silicate alteration; it lacks fracture control, is independent of young faults and is overprinted by SR<sub>1</sub>, SR<sub>2a</sub> and SR<sub>2c</sub> alteration. The SR<sub>2b</sub> alteration is interpreted as a low-temperature overprint by cooled K-silicate fluids and is an intrinsic part of the hydrothermal system. The alteration is light green in colour and minor pyrite is the only associated sulphide. Illite alteration may lower, or at least redistribute, copper and/or gold mineralization where it is most intense.

## DEEP SODIC-CALCIC ALTERATION (DEEP PRP)

Sodic-calcic alteration occurs at depth across most of the deposit but is best developed at depth within the East Zone stock. It is a medium-green, pervasive alteration which comprises albite, epidote, chlorite, calcite, K-feldspar, minor pyrite and trace to locally minor chalcopyrite and molybdenite. It is associated with a deep subtype of low-density type B quartz-sulphide veins which contain abundant chlorite along with calcite and trace epidote and exhibit weakly developed K-feldspar alteration envelopes. It has transitional contacts with overlying K-silicate alteration, with which it is considered approximately coeval.

## ADVANCED ARGILLIC ALTERATION (SR2A, SR2C, AND SILICIFICATION)

Advanced argillic alteration occurs in the East Zone and is associated with some of the highest grade mineralization in the deposit. The alteration was controlled by the northeast-trending, steeply-dipping brittle-ductile fault zone described above. Advanced argillic alteration comprises two related assemblages, which are zoned around the brittle-ductile fault zone (Figure 9.1.1).

1. A core zone which includes silicification and quartz-pyrophyllite-pyrite-chalcopyrite alteration coincides with or lies immediately adjacent to rock affected by brittle-ductile deformation.
2. A surrounding zone affected by sericite-pyrophyllite-pyrite-bornite-digenite-covellite-tennantite alteration forms a broad, upward-flaring envelope to the core zone on its northwest side. Advanced argillic alteration is the youngest mineralizing hydrothermal event in the Pebble deposit. It overprints early K-silicate, illite and deep sodic-calcic alteration and is only overprinted by young, peripheral quartz-sericite-pyrite alteration.

### *Silicification*

Silicification is the main alteration at the northeast and southwest ends of the brittle-ductile fault zone (Figure 9.1.1). The alteration is coincident with the distribution of brittle-ductile deformation textures and did not apparently form outside the fault zone. These zones also locally contain minor pyrophyllite, and there is a marked increase in pyrite concentration and copper grade due to additional precipitation of chalcopyrite compared to adjacent zones affected only by K-silicate alteration; in contrast to pyrophyllite alteration in the central part of the brittle-ductile fault zone, however, the grade of gold is only weakly elevated. The silicification is pervasive and there are no obviously related veins.

### *Pyrophyllite Alteration (SR2c)*

Pyrophyllite alteration with quartz characterizes the central part of the brittle-ductile fault zone. Minor to trace diaspore, zunyite, kaolinite and dickite are also present. Pyrite, and to a lesser extent chalcopyrite, concentration is significantly higher than in earlier K-silicate alteration. High-sulphidation copper ore minerals (see below) are absent or extremely rare. There is no definite vein control although pyritic fractures with and without quartz are locally common. This alteration also occurs within, but also locally outside of, zones with brittle-ductile deformation textures. In some areas located near major, young, brittle faults, such as the ZG<sub>1</sub> and ZE faults, pyrophyllite has been replaced by post-hydrothermal illite or smectite.

### *Sericite Alteration (SR2a)*

This alteration forms a wide, upward-flaring alteration zone that forms outside, and extends well to the west of, the brittle-ductile fault zone (Figure 9.1.1). It is well-preserved south of the ZE fault, which has down-dropped the southern half of the Pebble East Zone about 300 m relative to the north. North of the ZE fault, this alteration has been mostly removed by erosion and is only preserved as relicts at the very top of the system. The mineralogy is dominated by white sericite; pyrite concentration is typically much higher in the shallow parts of this zone compared to older K-silicate alteration but decreases with depth. Mineralization comprises a high-sulphidation copper ore mineral assemblage represented by various combinations of hypogene bornite, covellite, digenite, enargite and tennantite-tetrahedrite. These minerals commonly rim and replace preexisting chalcopyrite and pyrite precipitated during early K-silicate alteration.

### LATE/PERIPHERAL QUARTZ-SERICITE-PYRITE ALTERATION (SR1)

This alteration is medium grey, massive, texture-destructive and replaces all other alteration types. It is dominated by quartz and sericite, has minor to trace ankerite, rutile and apatite, and contains 8% to 20% pyrite. Pyrite-dominated D veins are uniquely and ubiquitously found in 29 SR<sub>1</sub> domains. Pyrrhotite accompanies pyrite in a few drill holes located well outside the deposit. The SR<sub>1</sub> alteration is strongly developed at the margins of the deposit and is common as partial overprints in the core of the West Zone but is not found in the interior of the East Zone. The SR<sub>1</sub> alteration destroys pre-existing copper-molybdenum mineralization, but commonly contains 100 to 500 ppb gold. The SR<sub>1</sub> alteration yields outward to propylitic alteration.

### PROPYLITIC ALTERATION (PRP)

This alteration occurs mostly to the north of the deposit and is more weakly developed to the south, outside of the most intense SR<sub>1</sub> alteration. It is also present at depth beneath granodiorite sills and host sedimentary rocks outside of the East Zone stock where it is difficult to distinguish from sodic-calcic alteration. Mineralogy is chlorite, epidote, calcite, quartz, magnetite, and minor albite and hematite; it contains 3% pyrite along with trace chalcopyrite and molybdenite. Crosscutting relationships suggest that K-silicate and PRP alteration were approximately coeval. Propylitic alteration contains low densities of type H and polymetallic type E veins (see below).

## 9.1.2 MAJOR VEIN TYPES

The Pebble deposit contains several major vein types, most of which can be related to specific types of alteration and stages of metal introduction. The characteristics of these veins are summarized below in order of decreasing age.

### TYPE EB – HORNFELS-RELATED VEINS

These veins occur in Units Y and W and are currently interpreted to be intrinsic to hornfels, although formation during the earliest stages of K-silicate alteration is also possible. They are narrow, commonly high-density, planar fractures and veinlets with distinct, narrow, biotite-rich envelopes. Fracture fill is mostly quartz with variable pyrite and trace chalcopyrite. These veins do not have any obvious spatial relationship to mineralization.

## TYPES A, B AND C – QUARTZ AND QUARTZ-SULPHIDE VEINS

Most veins at Pebble are quartz-rich and sulphide-bearing, and have been subdivided into three major subtypes with additional variants. Vein types A, B and C manifest a complete continuum in mineralogy, timing and space. They are temporally and spatially related to early K-silicate alteration.

### *Type A Veins*

These are the oldest quartz-sulphide veins associated with the main stages of K-silicate alteration at Pebble. They are most common within the East Zone stock, and to a much lesser extent in granodiorite stocks in the West Zone. They are sinuous, discontinuous and commonly have diffuse, irregular contacts with their host rock. Minerals are mostly quartz, rarely with trace K-feldspar, and sulphides comprise less than 1% to 2% pyrite and chalcopyrite with rare molybdenite. K-feldspar envelopes are weakly and erratically developed. With depth, Type A veins increasingly assume characteristics of aplites or pegmatites with salmon-coloured K-feldspar and without significant sulphide.

### *Type B Veins*

This vein type is most closely associated with early K-silicate alteration and related mineralization. They are of highest concentration within and adjacent to the East Zone stock, but may be subordinate to type C veins in the West Zone. Type B veins are mostly planar, continuous and have sharp contacts with host rocks. They range from less than 1 mm to greater than 1 m in width. They are dominated by quartz but can also contain trace to minor biotite, K-feldspar, apatite and/or rutile; anhydrite has only been observed in samples from a few of the deepest drill holes. Sulphide minerals comprise sub-equal pyrite and chalcopyrite, and minor molybdenite; total sulphide concentration is typically 2% to 5%. Alteration envelopes contain mostly K-feldspar but abundant biotite is present where the veins cut more mafic host rocks. Sulphide minerals are commonly elevated in the envelopes compared to surrounding rock. With depth these veins contain proportionately greater biotite (commonly chloritized) and K-feldspar, minor epidote and calcite, lower sulphide concentrations with the exception of molybdenite and envelopes are less strongly developed.

### *Type C Veins*

This is a major sulphide-bearing vein type throughout the Pebble deposit, except within and immediately adjacent to the East Zone stock. They are mostly quartz with subsidiary ankerite, contain trace K-feldspar, magnetite and biotite, and have vuggy cores which may reflect post-precipitation dissolution of anhydrite. Sulphide concentration is commonly greater than 10% and comprises sub-equal pyrite and chalcopyrite and highly variable molybdenite. The veins are planar and mostly less than 1 cm in width. They have strong K-feldspar-sulphide envelopes which are much wider than the vein and contain some of the highest grade mineralization in the deposit.

## TYPE M – MAGNETITE-BEARING VEINS

The Type M veins occur only in the West Zone. They are most abundant within and in the immediate host rocks to diorite sills. They formed paragenetically between vein types B and C as part of early K-silicate alteration. These veins commonly contain quartz, and can have high concentrations of pyrite and chalcopyrite. They are planar to irregular, and range up to greater than 10 cm in width. They have narrow K-feldspar alteration envelopes.

#### TYPE H – PROPYLITIC VEINS

These veins are found within propylitic alteration zones below and lateral to the Pebble deposit. They contain variable combinations of quartz, calcite, pyrite, magnetite (commonly hematized), earthy to specular hematite, chlorite and/or epidote and locally contain trace chalcopyrite or molybdenite. Envelopes are narrow and contain sericite, chlorite and minor pyrite. Type H vein are planar, mostly less than 1 cm in width and occur in low densities.

#### TYPE D – PYRITE-DOMINATED VEINS

Type D veins are intimately associated with peripheral/late SR<sub>1</sub> alteration. In the East Zone, D veins are found almost exclusively at the north and south margins of the deposit where intense SR<sub>1</sub> alteration overprints K-silicate alteration and associated mineralization. The D veins are more widely distributed throughout the West Zone where SR<sub>1</sub> overprints are common. In most cases they contain only pyrite, but can also contain up to 50% quartz with minor carbonate. In rare cases they contain minor chalcopyrite; pyrrhotite has been observed only in veins from DDH-7358 located north of the East Zone. They are mostly planar and range from hairline fractures to greater than 50 cm in width. They have wide, intense alteration envelopes which contain mostly quartz, pyrite and sericite.

#### TYPE E – POLYMETALLIC VEINS

Polymetallic veins are most abundant between the West Zone and the 25 Gold Zone located 4 km to the south, and are present in lesser concentrations north of the West Zone. They occur erratically throughout the West Zone, but are extremely rare in the East Zone. These veins are typically planar and can be greater than 1 m in width. Minerals are variable combinations of sphalerite, galena, chalcopyrite, pyrite, pyrrhotite, telluride minerals, gold, silver minerals, tetrahedritetennantite, quartz and calcite. Sericite-rich envelopes are common and can be very wide.

#### TYPE F – LATE CALCITE VEINS

These veins are dominated by white calcite with minor quartz and trace pyrite and lack envelopes. They fill dilatant fractures in damage zones which surround post-hydrothermal brittle faults and are unrelated to the Pebble deposit.

#### QUARTZ VEIN DENSITY

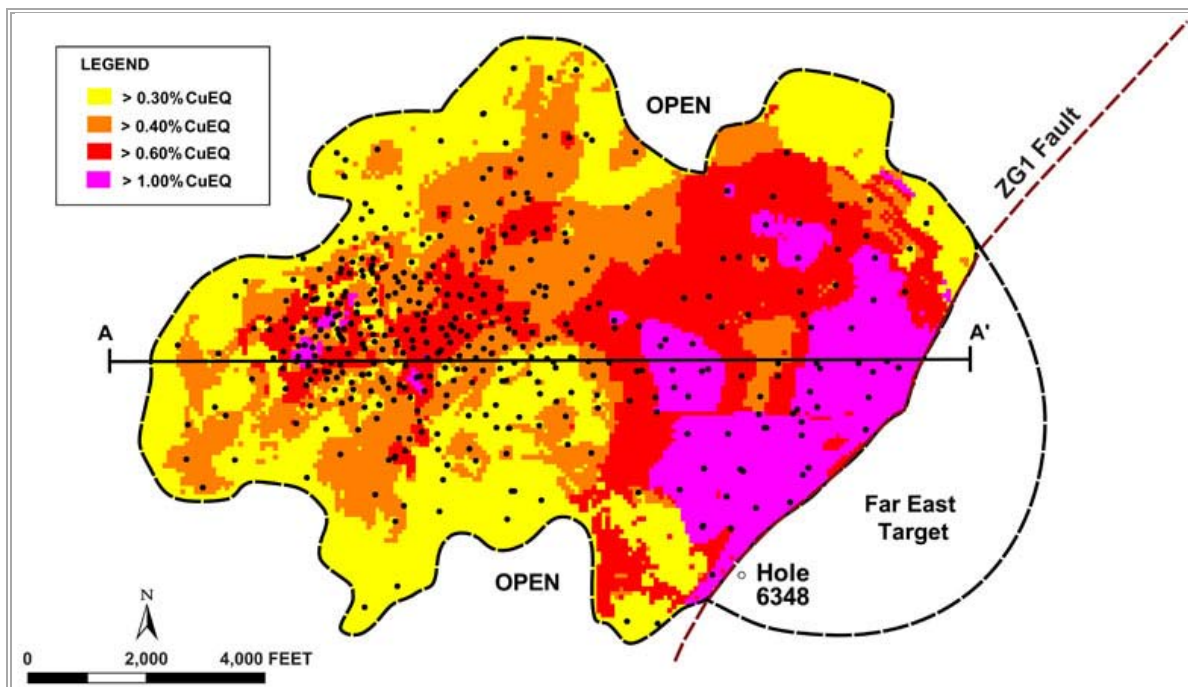
The total combined density of quartz-sulphide vein types A, B and C is 5% to 15% across most of the Pebble deposit. Much higher total densities occur in the central part of the East Zone, to the north and south of the ZE fault, where vein density rapidly increases to core zones which contain 50% to 90% quartz vein material. Intervals with greater than 50% total quartz vein density are logged as rock type Unit Q for geotechnical purposes, although they reflect hydrothermal effects. There are two domains of Unit Q; the first forms a broadly linear, steeply-dipping zone 100 to 300 m in width. This domain is coincident with the central part of the brittle-ductile fault zone and is truncated by the ZG<sub>1</sub> fault on its east side. The second domain occurs to the northwest in the approximate centre of the East Zone. It forms a broadly cylindrical zone which is at least 600 m in vertical extent, but which is underlain by rock with K-silicate alteration and background quartz vein density. Both Unit Q domains are enclosed by envelopes with 20% to 50% quartz veins.

The Unit Q bodies are interpreted as hydrothermal centres which were active during formation of early K-silicate alteration and associated mineralization. The linear body of Unit Q was controlled by an early stage of the brittle-ductile fault zone. The cylindrical body may have been controlled by a thus far unidentified structure or reflect lateral fluid flow beneath less permeable, now-eroded flysch, which would have been located above the East Zone stock.

### 9.1.3 STYLES OF MINERALIZATION

Mineralization in the Pebble West Zone is mostly hypogene but also includes minor oxide (leached) and underlying supergene zones. Mineralization in Pebble East is entirely hypogene, without evidence for leaching or paleo-supergene effects below the unconformity with the cover sequence. The distribution of copper, molybdenum and gold are discussed in later sections of this report.

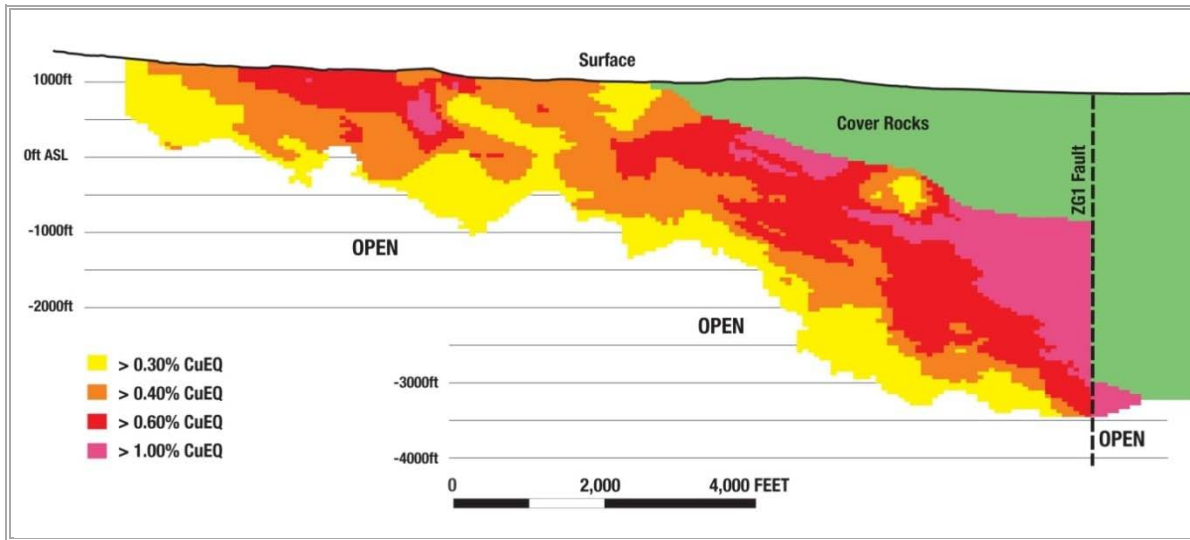
**Figure 9.1.2 Plan View of Relative Mineralization Concentration of the Pebble Deposit (Grade Calculated as CuEQ)**



Note: see Table 1.6.1 or Chapter 17 for details on CuEQ calculations.



**Figure 9.1.3 Cross-section A-A' of Pebble Deposit Showing Grade as CuEQ**



Note: see Table 1.6.1 or Chapter 17 for details on CuEQ calculations.

#### OXIDE ZONE

This zone forms a variably leached cap at the top of the West Zone. It rarely exceeds a very few tens of metres in thickness but extends to greater depth in a fractured corridor which extends to the northwest from the approximate centre of the West Zone. In many cases leaching is only partial, and at least some sulphide remains intact.

In general, most copper was leached, whereas gold remained essentially intact. Locally, very minor malachite, chrysocolla, native copper and/or other secondary copper minerals are present. The oxide zone is defined by a combination of visual criteria and copper speciation analyses described elsewhere in this report.

#### SUPERGENE ZONE

Supergene mineralization occurs only in the West Zone, immediately below the oxide zone. In most cases it is only partially developed, and commonly retains relict hypogene chalcopyrite. The main secondary copper minerals are chalcocite and covellite (Casselman, 2001); other minerals may be present but have not yet been well-documented. The supergene zone has been defined by copper speciation analysis (see below) combined with visual identification of chalcocite and related minerals in drill core. Supergene effects abate gradually with depth and are not marked by an abrupt boundary with underlying hypogene mineralization. There is no supergene mineralization in Pebble East below the unconformity with younger cover rocks.

#### HYPOGENE ZONE

The vast majority of mineralization in both the West and East Zones is hypogene. There are two distinct assemblages of hypogene mineralization.

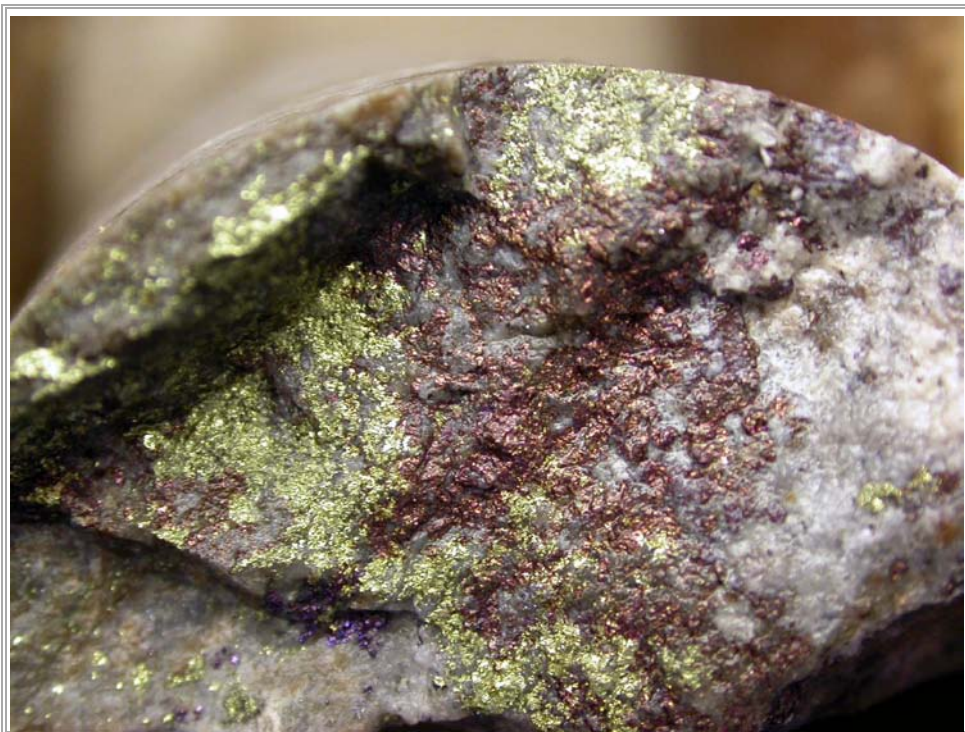
### *Chalcopyrite-Dominated Hypogene*

This is the most common type and occurs in all but certain parts of the East Zone, as described below. It contains chalcopyrite as the only significant copper mineral. The pyrite to chalcopyrite ratio ranges from less than 1 to nearly 10; high ratios are most common in the upper part of the southern half of the East Zone, on the north and south flanks of the deposit where low-pyrite K-silicate alteration with strong mineralization has been partially overprinted by pyrite-rich SR<sub>1</sub> alteration and in some parts of the advanced argillic alteration zone. Most of the East Zone has a low ratio. The West Zone has a higher ratio, with a domain in the approximate centre of the deposit which commonly has ratios greater than 5, due at least in part to overprints by SR<sub>1</sub> alteration. Some parts of the East Zone, mostly in the lower sills in the northern part of the zone, also contain bornite which co-precipitated with chalcopyrite (without other copper minerals); this is volumetrically very subordinate to chalcopyrite-only mineralization.

### *Replacement Bornite Hypogene*

The second type of hypogene mineralization occurs in the upper part of the south half of the East Zone, where it is an intrinsic part of the sericite envelope sub-zone of advanced argillic alteration. In this zone, an early stage of normal, chalcopyrite-dominated hypogene mineralization which precipitated during early K-silicate alteration has been partially replaced by a variable assemblage of hypogene bornite, digenite, covellite, tennantite-tetrahedrite and/or minor enargite related to advanced argillic alteration. In most cases the non-chalcopyrite copper minerals comprise only a minor proportion of hypogene mineralization but locally, and in comparatively small volumes, are the main copper phases (Figure 9.1.4).

**Figure 9.1.4 Core Photo Showing Chalcopyrite and Bornite Mineralization**



**Figure 9.1.5 Core Photo Showing Chalcopyrite Mineralization**



#### **9.1.4 OTHER MINERALIZED ZONES IN THE PEBBLE DISTRICT**

Historical exploration in the Pebble district has identified several zones of Eocene and mid-Cretaceous hydrothermal mineralization outside the Pebble deposit (Figure 9.1.6). The characteristics and exploration history of these areas have been discussed in detail in Technical Reports by Rebagliati and Haslinger (2003, 2004), Haslinger et al. (2004) and Rebagliati and Payne (2005, 2006, 2007), available at [www.sedar.com](http://www.sedar.com), and are only summarized here. No exploration work has been completed on any of these areas since 2004 except for limited drilling in the 308 and 65 Zones during 2010.

##### **EOCENE MINERALIZATION**

There are two identified zones with mineralization of Eocene age (Figure 9.1.6):

- The Mount Sharp occurrence contains narrow, discontinuous, scattered quartz veins with epithermal textures and highly anomalous grades for gold and silver.
- The Sill deposit occurs on the southeast flank of Kuktuli Mountain and manifests numerous epithermal quartz veins and associated zones of silicification with significant, multi-gram grades in gold and silver.

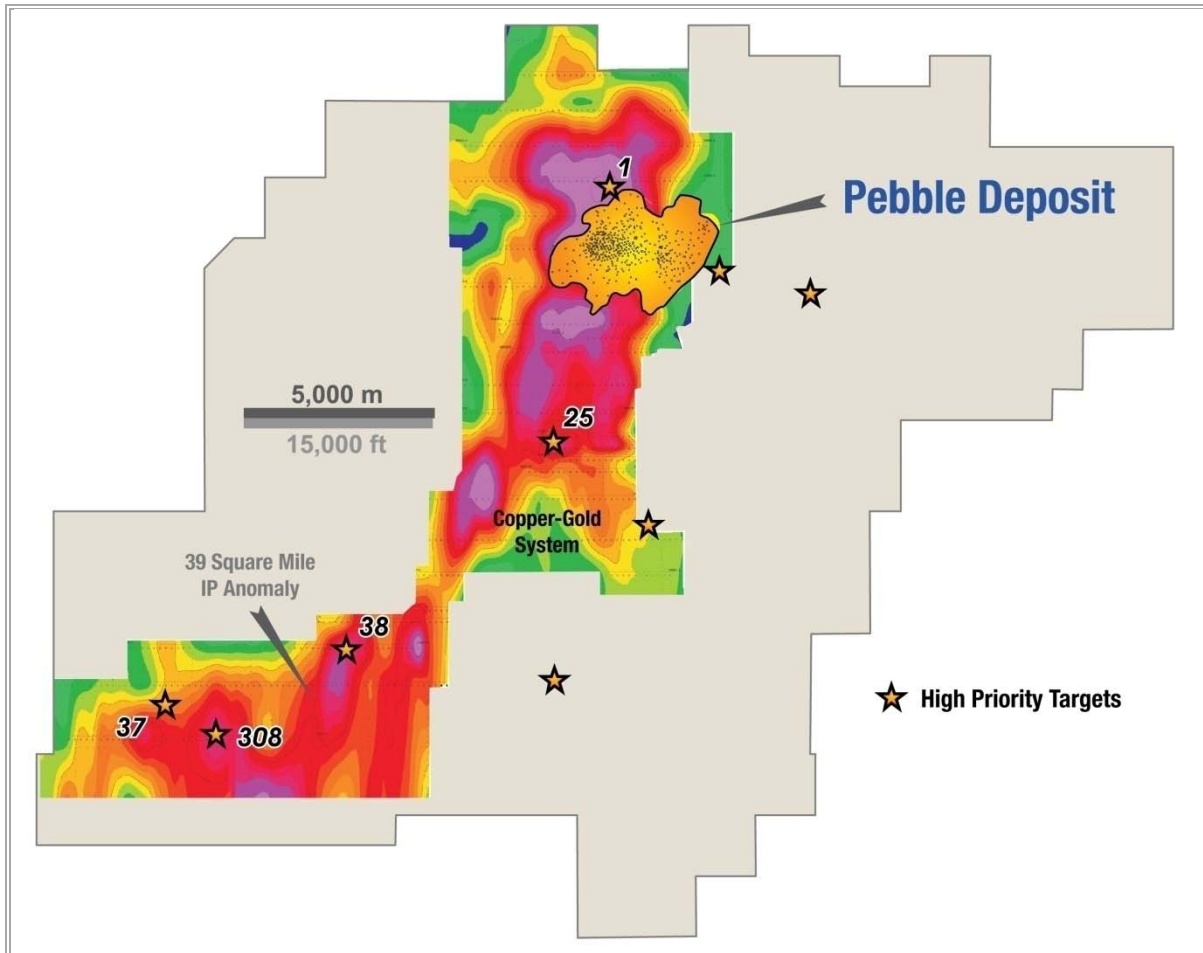
## CRETACEOUS MINERALIZATION

There are several identified zones with Cretaceous mineralization (Figure 9.1.6) which, where isotopically dated have returned ages comparable to those from the Pebble deposit.

- The Number One gold showing is located immediately northwest of the ZF fault, adjacent to the Pebble West Zone. Mineralization comprises gold grades to greater than one gram per tonne related to pyrite veins hosted by intense quartz-sericite-pyrite and lesser propylitic alteration.
- The 25 Zone is located about 4-5 km south of the Pebble deposit. It comprises auriferous, commonly polymetallic quartz and quartz-carbonate veins hosted by alkalic pyroxenite and biotite monzonite or syenomonzonite.
- The 52 Porphyry Zone is located in the southwest corner of the district. It manifests anomalous values for copper and molybdenum in mafic volcanic rocks with weak propylitic and K-silicate alteration near the south margin of the Kaskanak batholith.
- The 308 Porphyry Zone is located south of the Kaskanak batholith in the southernmost part of the district. The copper-molybdenum-gold mineralization occurs within a granodiorite intrusion similar to those found in the Pebble deposit and is associated with K-silicate and quartz-sericite-pyrite alteration cut by quartz-sulphide veins.
- The 38 Porphyry Zone occurs in granodiorite at the southeast margin of the Kaskanak batholith. It is a significant zone of copper-molybdenum-gold mineralization associated with quartz-sulphide veins and K-silicate, propylitic and quartz-sericite-pyrite alteration.
- The 37 Skarn Zone is hosted by mafic volcanic rocks near the southern margin of the district. Mineralization is mostly copper-gold in veins related to calc-silicate alteration.

The 65 Zone is hosted by sedimentary rocks and granodiorite intrusions similar to those at Pebble. It is located in the southeast part of the Pebble property and manifests relict K-silicate alteration overprinted by intense quartz-sericite-pyrite alteration and, locally, by illite alteration. Mineralization comprises strongly anomalous molybdenum with lesser copper and gold related to quartz veins.

**Figure 9.1.6 Cretaceous Mineralization and New Deposit Targets**





## 10.0 EXPLORATION

---

### 10.1 OVERVIEW

---

Geological, geochemical, and geophysical surveys were conducted in the Pebble project area from 1985 to 1997 by Cominco, from 2001 to 2007 by Northern Dynasty, and since mid-2007 by the Pebble Partnership. The types of historical surveys and their results are summarized below. More detailed descriptions of historical exploration programs and results may be found in Technical Reports by Rebagliati and Haslinger (2003, 2004), Haslinger et al. (2004), Rebagliati and Payne (2005, 2006, 2007), and Rebagliati et al. (2008), all of which are available at [www.sedar.com](http://www.sedar.com).

#### 10.1.1 GEOLOGICAL MAPPING

Between 2001 and 2006, the entire Pebble property was mapped for rock type, structure, and alteration at a scale of 1:10,000. This work provided an important geological framework for interpretation of other exploration data and drilling programs. A geological map of the Pebble deposit was also constructed, but in the absence of outcrop is based solely on drill hole information. The content and interpretation of district and deposit scale geological maps have not changed materially from the information presented by Rebagliati et al. (2009).

#### 10.1.2 GEOPHYSICAL SURVEYS

Dipole-dipole induced polarization (IP) surveys for a total of 122 line-km were completed by Zonge Geosciences for Teck Cominco between 1988 and 1997, and an additional 31 line-km were completed by Zonge Geosciences for Northern Dynasty in 2001. This work defined a chargeability anomaly about 91 km<sup>2</sup> in extent within Cretaceous rocks which surround the Kaskanak batholith on its eastern to southern margins. The anomaly measures about 21 km north-south by up to 10 km east-west; the western margin overlaps the contact of the Kaskanak batholith, and to the east the anomaly is masked by the Late Cretaceous to Eocene cover sequences (Casselmann and Osatenko, 1996; Zonge, 1997). The broader anomaly was found to contain 11 distinct centres reflected by stronger chargeability anomalies, many of which were later demonstrated to be coincident with extensive copper, gold and molybdenum soil geochemical anomalies. All known zones of mineralization of Cretaceous age in the Pebble district occur within the broad IP anomaly. Since the second half of 2009, a total of 194 line-km of IP chargeability and resistivity data were collected by Zonge Engineering and Research Organization Inc. for Pebble Partnership. This survey was conducted in the southern part of the property and used a line spacing of about 900 m. The objective of this survey is to extend the area of IP coverage completed prior to 2001.

A ground magnetometer survey totalling 18.7 line-km was completed at Pebble during 2002. The survey was conducted by MPX Geophysics Ltd., based in Richmond Hill, Ontario. The principal

objective of this survey was to obtain a higher resolution of magnetic patterns than was available from existing regional government magnetic maps.

The focus of this work was the area surrounding mineralization in the 37 Skarn zone in the southern part of the Pebble district. A helicopter-airborne magnetic survey was flown over the entire Pebble property in 2007. A total of 2,344 line-km were flown at 200 m line spacing. The survey covered an area of 426 km<sup>2</sup>. The survey lines were flown at a nominal mean terrain clearance of 60 m along flight lines oriented 135° at a line spacing of 200 m, with tie lines oriented 045° at a spacing of 2,000 m. An area of 37.4 km<sup>2</sup> located over the Pebble deposit was flown at 100 m line spacing for a total of 342 line-km, without additional tie lines.

A further 6,452 line-km of airborne EM and magnetometer geophysics completed on the property in 2010. This ZTEM survey was acquired by Geotech Ltd. of Aurora, Ontario.

A limited magnetotelluric survey was also completed during 2007. The survey was conducted by GSY-USA Inc., the U.S. subsidiary of Geosystem SRL of Milan, Italy, under the supervision of Northern Dynasty geologists. The survey focused on the area of drilling in the Pebble East zone and comprised 196 stations on 9 E-W lines and 1 N-S line, at a nominal station spacing of 200 m. Interpretation, including 3D inversion, was completed by Mr. Donald Hinks of RTZ. In July 2009, Spectrem Air Limited, an Anglo American affiliated company based in South Africa, completed an airborne electromagnetic, magnetic and radiometric survey over the Pebble area. A total of 3,840 line-km were surveyed in two flight block configurations:

- a regional block covering an area of about 30 x 12 km at a line spacing of 1.5 km; and
- a more detailed block which covered the Pebble property using a line spacing of 250 m.

The orientation of flight lines was 135° for both surveys with additional tie-lines flown orthogonally. The objective of this work included provision of geophysical constraints for structural and geological interpretation in areas with significant glacial cover.

### 10.1.3 GEOCHEMICAL SURVEYS

Cominco undertook several soil geochemical surveys on the Pebble property and collected a total of 7,337 samples between 1988 and 1995 (Bouley et al., 1995). Northern Dynasty collected an additional 1,026 soil samples between 2001 and 2003. Typical sample spacing in the central part of the large geochemical grid was 30 to 76 m (100 to 250 ft) along lines spaced 122 to 229 m (400 to 750 ft) apart; samples were more widely spaced near the north, west, and southwest margins of the grid.

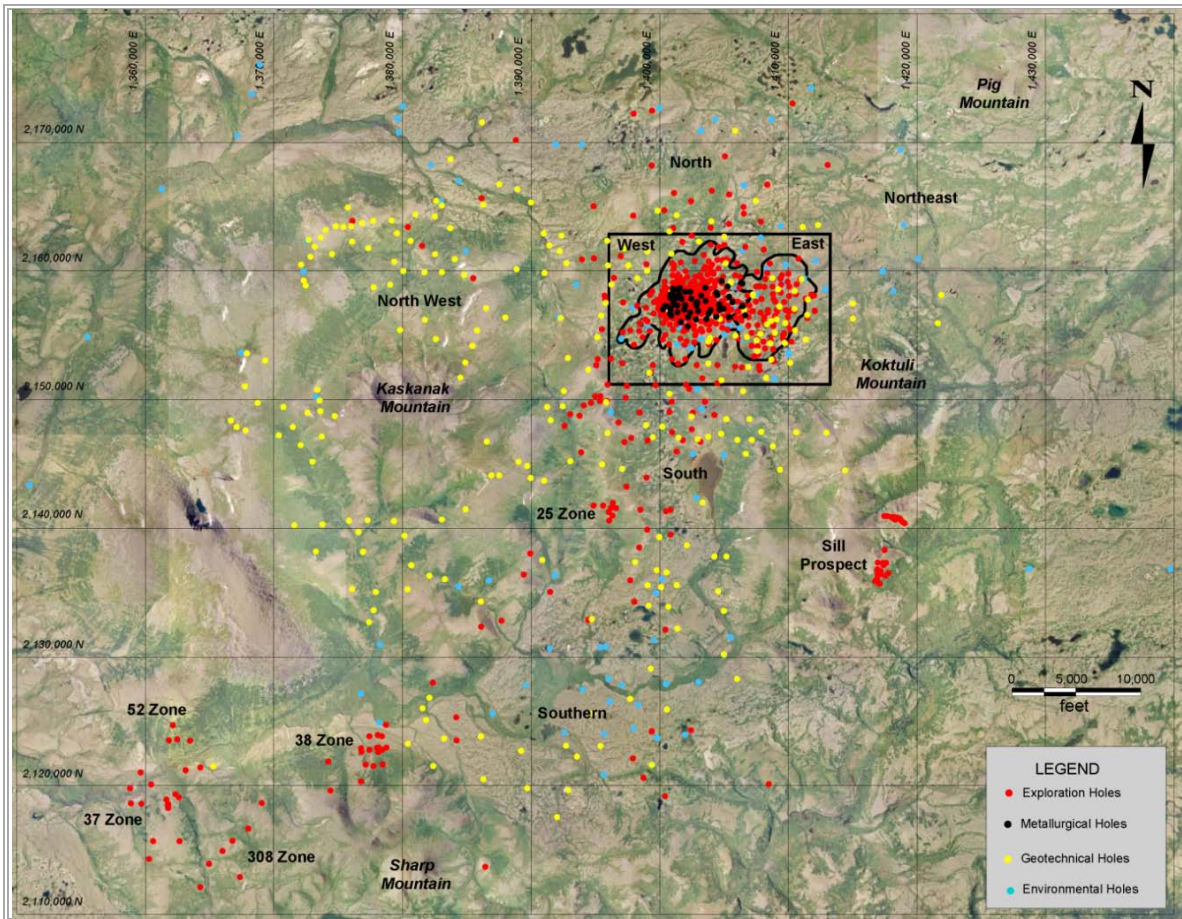
These sampling programs outlined high contrast, coincident anomalies in gold, copper, molybdenum, and other metals in an area that measures 9 km (5.6 miles) north-south by up to 4 km (2.5 miles) east-west, with strong but smaller anomalies in several outlying zones. All soil geochemical anomalies lie within the IP chargeability anomaly described above. No geochemical surveys have been completed by Northern Dynasty or the Pebble Partnership since 2003.



## 11.0 DRILLING

Extensive drilling has taken place at the Pebble Project over 15 different years. A total of 948,638 ft (289,145 m) has been drilled in 1,158 holes on the Pebble property to 2010. The coverage and type of holes drilled are illustrated in Figure 11.1.1.

**Figure 11.1.1 Location of Drill Holes – Pebble Deposit District**



Reconnaissance exploration by Cominco in the Pebble area in 1986 was a continuation of regional exploration initiated in the mid-1980s. Examination and sampling of several color anomalies in 1987 yielded the Pebble discovery outcrop, which was of uncertain affinity. The 1988 exploration program included the drilling of 24 diamond drill holes at the Sill epithermal gold prospect, soil sampling, geological mapping and the drilling of two diamond drill holes on the Pebble target. Work continued in 1989, with an expanded soil sampling program, an IP survey and the completion of 9 diamond drill holes at the Pebble target and 15 additional holes at the Sill prospect. Although limited in scope, the IP survey displayed a response characteristic of a large porphyry copper system. This interpretation was validated by subsequent drilling at the Pebble target, which intercepted long intervals of porphyry-

style copper and gold mineralization. In 2004, drilling by Northern Dynasty identified a significant, new porphyry centre on the eastern side of the Pebble deposit (the Pebble East zone) beneath a cover of Tertiary rocks that becomes progressively thicker to the east.

All drill collars have been surveyed using either differential GPS or total station measurements, and a digital terrain model for the site has been generated by photogrammetric methods. All post-Cominco drill holes have been surveyed down hole, typically using a single shot magnetic gravimetric tool. A total of 940 holes are drilled vertically (-90 degrees) and 218 are inclined from -42 to -85 degrees at various azimuths.

## 11.2 SUMMARY OF DRILLING 1988 TO 2010

---

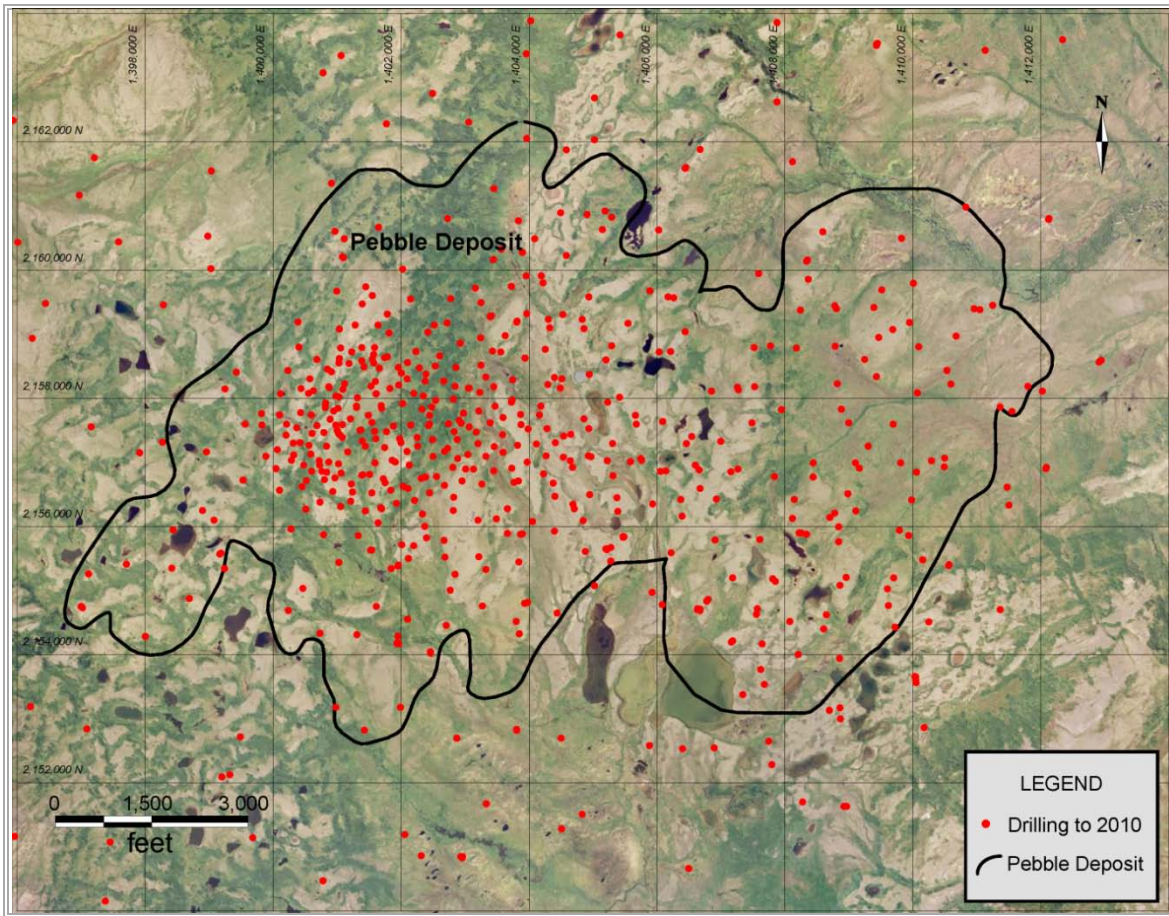
The Pebble district has been drilled extensively (Figure 11.2.1). Drilling statistics and a summary of drilling by various categories to the end of the 2010 exploration program are compiled in Table 11.2.1, overleaf. This includes seven drill holes completed by Full Metal Minerals in the Pebble district in 2008 and recently added to the Pebble dataset. Detailed descriptions of the programs and results for 2009 and preceding years may be found in Technical Reports by Rebagliati and Haslinger (2003, 2004), Haslinger et al. (2004), Rebagliati and Payne (2005, 2006, 2007), and Rebagliati et al. (2008, 2009, 2010), available at [www.sedar.com](http://www.sedar.com).

Most of the footage on the Pebble Project was drilled using diamond core drills. Only 18,716 ft (5,705 m) was percussion-drilled, from 222 rotary drill holes. All holes reported as core were drilled through overburden, in most cases by tricone bit with no core recovery. These overburden lengths are included in the core drilling total.

Highlights of drilling between 1988 and 2010 include:

- Initial drilling by Cominco focused on the Sill epithermal deposit, where 39 holes were drilled for a total of 10,446 ft (3,184 m) in 1988 and 1989; no further work has been conducted in this deposit since. The Sill deposit comprises quartz veins and replacements which host gold and silver mineralization. It is of Eocene age and is not related to the rest of mineralization in the district, including the Pebble deposit, which is Cretaceous in age.

**Figure 11.2.1** Location of Drill Holes – Pebble Deposit Area



**Table 11.2.1 Summary of Drilling in the Pebble District to December 2010**

<b>PEBBLE DRILLING SUMMARY</b>			
<b>BY OPERATOR</b>			
Operator	# Holes	Feet	Metres
Cominco <sup>1</sup>	164	75,741.0	23,086
NDM	576	494,778.0	150,808
PLP <sup>2</sup>	411	372,669.3	113,590
FMM	7	5,450.0	1,661
<b>TOTAL</b>	<b>1,158</b>	<b>948,638.3</b>	<b>289,145</b>
<b>BY TYPE</b>			
Purpose	# Holes	Feet	Metres
Core <sup>1,5</sup>	936	929,922.6	283,440
Percussion <sup>6</sup>	222	18,715.6	5,704
<b>TOTAL</b>	<b>1,158</b>	<b>948,638.2</b>	<b>289,145</b>
<b>BY YEAR</b>			
Year	# Holes	Feet	Metres
1988 <sup>1</sup>	26	7,601.5	2,317
1989 <sup>1</sup>	27	7,422.0	2,262
1990	25	10,021.0	3,054
1991	48	28,129.0	8,574
1992	14	6,609.0	2,014
1993	4	1,263.0	385
1997	20	14,695.5	4,479
2002	68	37,236.8	11,350
2003	67	71,226.6	21,710
2004	266	165,481.2	50,439
2005	114	81,978.5	24,987
2006 <sup>3</sup>	47	72,621.9	22,135
2007 <sup>4</sup>	92	167,666.9	51,105
2008 <sup>5</sup>	241	184,726.4	56,305
2009	33	34,947.6	10,652
2010	66	57,011.3	17,377
<b>TOTAL</b>	<b>1,158</b>	<b>948,638.3</b>	<b>289,145</b>
<b>BY AREA</b>			
Area	# Holes	Feet	Metres
East	110	435,613.5	132,775
West	404	316,337.1	96,420
Main <sup>7</sup>	85	8,568.2	2,612
NW	157	32,235.4	9,825
North	40	22,630.5	6,898
NE	10	1,097.0	334
South	69	29,129.9	8,879
25 Zone	8	4,047.0	1,234
37 Zone	7	4,252.0	1,296
38 Zone	20	14,221.5	4,335
52 Zone	5	2,534.0	772
308 Zone	1	879.0	268
Eastern	5	621.5	189
Southern	155	59,073.4	18,006
SW	43	6,952.8	2,119
Sill	39	10,445.5	3,184
<b>TOTAL</b>	<b>1,158</b>	<b>948,638.3</b>	<b>289,145</b>
<b>BY PURPOSE</b>			
Purpose	# Holes	Feet	Metres
Exploration <sup>1,5</sup>	623	801,908.8	244,422
Geotechnical	245	65,152.1	19,858
Metallurgical	60	56,023.0	17,076
Environmental	230	25,554.4	7,789
<b>TOTAL</b>	<b>1,158</b>	<b>948,638.3</b>	<b>289,145</b>

1. Includes holes drilled on the Sill prospect.
2. Holes started by NDM and finished by PLP are included as PLP.
3. Drill holes counted in the year in which they were completed.
4. Wedged holes are counted as a single hole including full length of all wedges drilled.
5. Includes Full Metal Minerals (FMM) drill holes. Data acquired in 2010.
6. Shallow (<15 ft) augur holes not included.
7. Comprised of holes drilled entirely in Tertiary cover rocks within the Pebble West and Pebble East areas.

- Most of the remaining 65,296 ft (19,902 m) of drilling by Cominco was completed in the immediate vicinity of the Pebble West zone. Most Cominco holes were between 370 and 700 ft (113 and 213 m) in length; only 5 exceeded 900 ft (274 m) in length with the deepest drilled to a depth of 1,500 ft (457 m). Drill spacing ranged from 300 to 750 ft (91 to 229 m) throughout much of the Pebble West deposit, increasing to up to 1,000 ft (305 m) on the margins. In the higher-grade core of the Pebble West deposit, drill holes had a spacing of 200 to 240 ft (61 to 73 m). Interestingly, 50% of Cominco drill holes in the Pebble West zone bottomed in sulphide mineralization with grades of 0.60% CuEQ or higher, and 96% bottomed in mineralization with grades higher than 0.30% CuEQ. The depth extension of this mineralization was tested during later drill programs by Northern Dynasty. Cominco completed a few, generally shallow, holes for a total of 3,573 ft (1,089 m) within the broad IP chargeability and geochemical anomaly to the south and southwest of the Pebble West deposit.

- Northern Dynasty drilled 68 holes for a total of 37,237 ft (11,350 m) during 2002. The objective of this work was to test the strongest IP chargeability and multi-element geochemical anomalies outside of the Pebble deposit, as known at that time, but within the larger and broader IP chargeability anomaly described above. This program discovered the “38 Zone” porphyry copper-gold-molybdenum deposit, the “52 Zone” porphyry copper occurrence, the “37 Zone” gold-copper skarn deposit, the “25 Zone” gold deposit, and several small occurrences in which gold values exceeded 3.0 grams per tonne.
- In 2003, Northern Dynasty drilled 67 holes for a total of 71,227 ft (21,710 m), mainly within and adjacent to the Pebble West zone to determine continuity of mineralization and to identify and extend higher grade zones. Most holes were drilled to the zero m elevation above mean sea level, and were 900 to 1,200 ft (274 to 366 m) in length. Eight holes for a total of 5,804 ft (1,769 m) were drilled outside the Pebble deposit to test for extensions and new mineralization at four other zones on the property, including the 38 Zone porphyry copper-gold-molybdenum deposit and the 37 Zone gold-copper skarn deposit.
- Drilling by Northern Dynasty in 2004 totalled 165,481 ft (50,439 m) in 266 holes. Of this, 39,993 m was drilled in 147 exploration holes in the Pebble deposit, and 879 ft (268 m) in one exploration hole in the southern part of the property which discovered the 308 Zone porphyry copper-gold-molybdenum deposit. Additional drilling included: 21,335 ft (6,503 m) in 26 metallurgical holes in Pebble West, 9,127 ft (2,782 m) in 54 geotechnical holes, and 2,933 ft (894 m) in 38 water monitoring holes, of which 33 holes for a total of 2,638 ft (804 m) were percussion holes.
- In 2005, Northern Dynasty drilled 81,979 ft (24,987 m) in 114 holes. Of these drill holes, 13 for a total of 12,198 ft (3,718 m) were drilled mainly for engineering and metallurgical purposes in the Pebble West zone. Seventeen drill holes for a total of 60,696 ft (18,500 m) were drilled in the Pebble East zone and the results confirmed its presence and further demonstrated that it was of large size and contained higher grades of copper, gold and molybdenum than the Pebble West zone. The Pebble East zone remained completely open at the end of 2005. A further 13 holes for a total of 2,986 ft (910 m) were cored for engineering purposes outside the Pebble deposit area. A further 6,099 ft (1,859 m) of drilling was completed in 71 non-core water monitoring wells.
- Drilling during 2006 focused on further expansion of the Pebble East zone. Drilling comprised 72,622 ft (22,135 m) in 47 holes. Twenty of these holes were drilled in Pebble East, including 17 exploration holes and three engineering holes, for a total of 68,504 ft (20,880 m). The Pebble East deposit again remained fully open at the conclusion of the 2006 drilling program. In addition, 2,710 ft (826 m) were cored in 14 engineering holes and 1,407 ft (429 m) were drilled in 13 monitoring well percussion holes elsewhere on the property.
- Drilling by Northern Dynasty and the Pebble Partnership during 2007 continued to focus on the Pebble East zone. A total of 151,306 ft (46,118 m) of delineation drilling in 34 holes extended Pebble East to the northeast, northwest, south and southeast; the zone nonetheless remained open in these directions, as well as to the east in the East Graben. Additional drilling included 10,167 ft (3,099 m) in 9 metallurgical holes in Pebble West, and 4,367 ft (1,331 m) in 26 engineering holes and 1,824 ft (556 m) in 23 percussion holes for monitoring wells across the district.

- In 2008, the Pebble Partnership drilled 179,275 ft (54,643 m) in 234 holes, the most extensive drilling on the Pebble Project in any year to date. A total of 136,266 ft (41,534 m) of delineation and infill drilling, including 6 oriented holes, was completed in 31 holes in Pebble East. This drilling further expanded the Pebble East zone. Fifteen metallurgical holes for a total of 14,511 ft (4,423 m) were drilled in Pebble West. One 2,949 ft (899 m) Cretaceous rock infill/geotechnical hole was drilled in Pebble West. Geotechnical drilling elsewhere on the property included 105 core holes for a total of 18,806 ft (5,732 m). Hydrogeology and geotechnical drilling outside of the Pebble deposit accounted for 82 percussion holes for a total of 6,745 ft (2,056 m). In 2010, the Pebble Partnership acquired the data for seven holes totalling 5,450 ft (1,661 m) drilled by Full Metal Minerals in 2008.
- The Pebble Partnership drilled 34,948 ft (10,652 m) in 33 core drill holes in 2009. Five delineation holes were completed for 6,076 ft (1,852 m) around the margins of Pebble West and 21 exploration holes for a total of 22,018 ft (6,711 m) were drilled elsewhere on the property. In addition, seven geotechnical core holes were drilled for a total of 6,854 ft (2,089 m).
- In 2010, The Pebble Partnership drilled 57,011 ft (17,377 m) in 66 core holes. Forty eight district exploration holes totalling 53,635 ft (16,348 m) were drilled over a broad area of the property outside the Pebble deposit. An additional 3,376 ft (1,029 m) were drilled in 18 geotechnical holes within the deposit area and to the west.

In 2009, the survey locations, hole lengths, naming conventions and numbering designations of the Pebble drill holes were reviewed. This exercise confirmed that several shallow, non-cored, overburden drill holes described in some engineering and environmental reports were essentially the near-surface pre-collars of existing bedrock diamond drill core holes. As these pre-collar and bedrock holes have redundant traces, the geologic information was combined into a single trace in the same manner as the wedged holes. In addition, a number of very shallow (less than 15 ft or 5 m), small diameter, water monitoring auger holes were relegated from the exploration drill hole database, as they did not provide any geological or geochemical information. This work was completed in January 2010.

A resurvey program was conducted during the 2008 and 2009 field seasons of all Pebble Project drill holes from 1988 through 2009. For consistency throughout the project, the resurvey program referenced the control network established by R&M Consultants in the US State Plane Coordinate System Alaska Zone 5 NAVD88 Geoid99. The resurvey information was applied to the drill collar coordinates in the database in late 2009.

### **11.3 THE 2010 DRILLING PROGRAM**

---

Details of the 2010 program included 53,636 ft (16,348 m) of core drilling of district exploration targets in 48 holes throughout the property. In addition, 3,375 ft (1,029 m) was completed in 18 cored geotechnical holes for engineering and hydrological purposes (Table 11.3.1).

**Table 11.3.1 Drilling in the Pebble Deposit during 2010**

Type	No. Holes	Length (ft)	Length (m)
Exploration	48	53,636	16,348
Geotechnical (Cored)	18	3,375	1,029
<b>Totals</b>	<b>66</b>	<b>57,011</b>	<b>17,377</b>

**11.3.1 DRILLING PROCEDURES, SURVEYS AND TYPES OF DRILLING IN 2010**

The 2010 drilling procedures were also identical to the 2008 program, with the three following exceptions:

1. All exploration holes were completed by American Recon Inc. and the geotechnical holes were completed by Foundex.
2. Acquisition of the geotechnical data on the core was not supervised by SRK Consulting.
3. Down hole orientation surveys were taken for all exploration holes at approximately 200 ft (60 m) intervals with the EZ-Shot system. No down hole surveys were performed on the geotechnical holes as they are generally less than 200 ft in length.

**11.3.2 RESULTS OF THE 2010 DRILLING PROGRAM**

The final results of the 2010 program are still pending at the time of this report.





## 12.0 SAMPLING METHOD AND APPROACH

---

The Pebble deposit is explored by extensive core drilling. A total of 73,085 samples were taken from drill core for assay analysis. Essentially all potentially mineralized Cretaceous core drilled and recovered, is sampled by halving it in 10 ft (3 m) lengths. Similarly, all core recovered from the Late Cretaceous to Early Tertiary cover sequence, (referred to as Tertiary in sections 12 and 13), is also sampled, typically on 20 ft (6.1 m) sample lengths, with some shorter sample intervals in areas of geologic interest. Unconsolidated overburden material, where it exists, is generally not recovered by core drilling and therefore not sampled.

Rock chips were generally not sampled for assay analysis from the 222 rotary percussion holes drilled for monitoring well and environmental purposes on the project. Only 35 samples in total were taken from the drill chips of 26 rotary percussion holes outside the Pebble deposit area for condemnation purposes.

For details of the main rock units in the Pebble deposit and mineralization dimensions see Chapter 7. Details of the mineralization are provided in Chapter 9. Summaries of relevant sample composites are obtained in Technical Reports by Rebagliati and Haslinger (2003, 2004), Haslinger et al. (2004), Rebagliati and Payne (2005, 2006, 2007), and Rebagliati et al. (2008), all of which are available at [www.sedar.com](http://www.sedar.com).

### 12.1 COMINCO DRILLING

---

Cominco drilled 125 holes in the Pebble area between 1988 and 1997 for a total of 65,295.5 ft (19,902 m). These holes, numbered 001 through 125 in the database, include 118 holes drilled in Pebble West and seven holes drilled elsewhere on the property. Of the Pebble West holes, 94 were drilled vertically and 20 were inclined from  $-45^{\circ}$  to  $-70^{\circ}$  at various orientations. Cominco also completed 39 drill holes on the Sill prospect for a total of 10,445.5 ft (3,184 m) in 1988 and 1989. These holes are numbered Sill 01 through Sill 39.

Cominco drill core was transported from the drill site by helicopter to a logging and sampling site in the village of Iliamna, Alaska. The core was typically sampled on a 10 ft (3 m) basis within the Pebble deposit and essentially all Cretaceous core was sampled. Samples from the Sill and other areas were typically 5 ft (1.5 m) in length, with shorter samples in areas of vein mineralization. The half-core samples were transported by air charter to Anchorage and by airfreight to Vancouver, BC. All coarse rejects from 1988 through 1997 and all pulps from 1988 and 1989 have been discarded. The remaining pulps were shipped to a secure warehouse at Port Kells, BC, for long-term storage.

A total of 6,311 core samples were taken from the 125 drill holes. On the Sill prospect, a total of 676 samples were taken from the 39 holes drilled.

## 12.2 NORTHERN DYNASTY 2002 DRILLING

---

In 2002, Northern Dynasty drilled 68 holes for a total length of 37,237 ft (11,350 m). These holes are numbered 2001 through 2068. All but one of these holes (2,036) were drilled outside the original Pebble main area, including 16 holes in the 38 zone, 5 in the 37 zone, 5 in the 25 Gold zone, 4 in the 52 zone, and 37 holes in areas to the south, west and north of Pebble West, 11 of which are now considered to be part of Pebble West. Of the 2002 holes, 37 were drilled vertically and 31 were inclined from -42° to -74° at various orientations.

The drill core was boxed at the drill rig and transported daily by helicopter to Northern Dynasty's secure logging facility in Iliamna. A total of 2,467 core samples, averaging 10 ft (3.0 m) in length, were taken by Northern Dynasty personnel from the 2" (5.08 cm) diameter NQ<sub>2</sub> core drilled in 2002. Sampling was performed by mechanically splitting the core in half lengthwise.

## 12.3 NORTHERN DYNASTY 2003 DRILLING

---

In 2003, diamond drill contractor, Quest America Drilling, Inc., drilled NQ<sub>2</sub> core at Pebble. A total of 71,227 ft (21,710 m) of drilling was completed in 67 holes. Of the holes completed in 2003, 61 were drilled at Pebble West, two in the 37 zone, one in the 38 zone and three elsewhere on the Pebble property. In Phase I, 25 widely-spaced holes numbered 3069 through 3093 were completed, and 1,973 samples were taken. In Phase II, 42 holes numbered 3094 through 3135 were completed, and 4,471 samples were taken. Of the 2003 holes, 11 were drilled vertically and 56 were inclined from -44° to -74° at various orientations.

The drill core was boxed at the drill rig and transported daily by helicopter to Northern Dynasty's secure logging facility at Iliamna. Samples from both phases averaged 10 ft (3 m) in length. Sampling was performed by mechanically splitting the core in half lengthwise. Coarse rejects were stored at SGS Mineral Services in Fairbanks, AK, until early 2005, and then discarded. The pulps were returned to Northern Dynasty and are stored at the Port Kells warehouse.

## 12.4 NORTHERN DYNASTY 2004 DRILLING

---

In 2004, the diamond drill contractor, Quest America Drilling, Inc., drilled NQ<sub>2</sub>, HQ (2.5"/6.35 cm diameter) and PQ (3.3"/8.31 cm diameter) core. Between May and October 2004, 162,844 ft (49,635 m) were drilled in 233 cored holes. Of the holes drilled in 2004, 164 were drilled in the Pebble West area, 10 were drilled in the Pebble East area (as subsequently defined) and 59 were drilled elsewhere on the property. The drill hole number sequence for the exploration program included 4136 through 4309, and GH04-001 through GH04-050 for the geotechnical program. Thirty-three rotary percussion "MW" and "P" series water well, engineering and environmental holes were also completed for a total of 2,638 ft (804 m). The 2004 drilling program included 26 large diameter (PQ and HQ) holes drilled in Pebble West for metallurgical testing (drill hole-id suffix "M"). A total of 237 holes were drilled vertically, including all holes in the Pebble East area, all holes from the GH, MW, and P series holes and all but

one Pebble West zone metallurgical hole. The remaining 29 holes, all in the Pebble West deposit, were inclined from  $-57.5^{\circ}$  to  $-85.5^{\circ}$  at various orientations.

The drill core was boxed at the drill rig and transported daily by helicopter to Northern Dynasty's secure logging facility in the village of Iliamna. A total of 12,865 Cretaceous (syn-mineralization) samples averaging 10 ft in length were taken in 2004; 10,893 samples were mechanically split half core samples and 1,972 samples were of the metallurgical type. The metallurgical samples were taken by sawing an off-centre slice representing 20% of the core volume, which was submitted for assay analysis. The remaining 80% was used for metallurgical purposes. In addition, 904 Tertiary (post-mineralization) samples averaging 15 ft (4.6 m) in length were taken for trace element analysis. Tertiary samples were taken by mechanically splitting the core in half lengthwise.

The average core recovery for all samples taken in 2004 was 97.6%.

## 12.5 NORTHERN DYNASTY 2005 DRILLING

---

In 2005, diamond drill contractor Quest America Drilling Inc. drilled NQ<sub>2</sub>, HQ and PQ core.

Between April and December 2005, 75,879 ft (23,128 m) were drilled in 43 core holes. Eighteen of the holes were drilled at Pebble East, 12 in Pebble West, and 13 in other areas. The drill hole number sequence for the exploration included 5310M through 5337 and GH05-051 through GH05-065 for the geotechnical series. Two holes were also drilled in the MW and P series. Of the "5000" series exploration holes, 10 were metallurgical holes (suffix "M"). A total of 33 holes were drilled vertically, including all the 2005 metallurgical holes and all holes from the GH, MW and P series. The remaining 10 holes were inclined from  $-60^{\circ}$  to  $-75^{\circ}$  at various orientations. In addition to the core drilling, a total of 6,100 ft (1,859 m) were completed in 71 rotary percussion holes for water monitoring purposes.

The drill core was boxed at the drill rig and transported daily by helicopter to Northern Dynasty's secure logging facility in the village of Iliamna. A total of 4,378 Cretaceous samples and 1,435 Tertiary samples were taken. Of the Cretaceous samples, 3,541 were taken by sawing the core in half lengthwise. The 837 samples from metallurgical holes were taken by the 20% off-centre saw method. The Tertiary samples were all of the 20% saw type. The Cretaceous samples averaged 10 ft in length and Tertiary samples averaged 20 ft (6.1 m) in length.

The average core recovery in 2005 was 98.4%.

## 12.6 NORTHERN DYNASTY 2006 DRILLING

---

The diamond drill contractors in 2006 were American Recon and Boart Longyear. Between April and December 2006, they drilled 71,215 ft (21,706 m) of NQ<sub>2</sub> and HQ core in 34 cored holes. The hole numbering sequence for 2006 included 17 Pebble East exploration holes numbered 6338 through 6355 (holes 6354 and 6356 were started in 2006 but completed in 2007, and are counted in 2007) and 17 "GH" series geotechnical holes numbered GH06-065 through GH06-080. A total of 13 shallow "P" series

environmental rotary percussion holes were completed for a total depth of 1,407 ft (429 m). All but five holes were drilled vertically; the non-vertical holes were drilled from -80° to -85° inclination.

The drill core was boxed at the drill rig and transported daily by helicopter to Northern Dynasty's secure logging facility in Iliamna. The 2,759 Cretaceous samples taken averaged 10 ft in length and the 1,847 Tertiary samples averaged 20 ft in length. The Cretaceous samples were taken by sawing the core in half lengthwise and the Tertiary samples were of the 20% off-centre saw type.

The average core recovery was 98.7%.

## 12.7 NORTHERN DYNASTY AND THE PEBBLE PARTNERSHIP 2007 DRILLING

---

American Recon and Boart Longyear, the diamond drill contractors in 2007, drilled a total of 165,842 ft (50,549 m) in 69 NQ<sub>2</sub>, and HQ diameter core holes between February and December, 2007. The hole numbering sequence for 2007 includes 6354 and 6356, and 7357 through 7400M.

A total of 34 holes were drilled in the Pebble East area and 9 metallurgical holes numbered 7390M to 7391M and 7395M to 7400M were drilled in the Pebble West area. Twenty-six GH series geotechnical holes numbered GH07-081 through GH07-106 were also drilled (two holes within the area of Pebble East, and 24 holes in other areas). Of the 2007 holes, 64 were vertical and the remaining five were inclined from -70° to -80° at various orientations. Of the 7000-series of drill holes, 14 were completed by Northern Dynasty, seven holes were started by Northern Dynasty were completed after the Pebble Partnership was formed, and 22 holes from 7376 onwards were completed by the Pebble Partnership. In addition, 1,825 ft (556 m) of drilling was completed in 23 vertical, non-cored holes for monitoring wells. Four drill holes (7358, 7368, 7369 and 7376) were wedged to complete the Cretaceous intersection in these areas after drilling difficulties were encountered in the parent holes. A total of five wedged holes numbered 7358W, 7368W, 7368W2, 7369W and 7376W were drilled.

Wedged holes that successfully extended beyond the total depth of the parent holes were treated as extensions of their parent holes and the overlapping information was relegated.

Drill holes 7386, 7387 and 7394 were collared in 2007 but were completed in 2008. They are included with the 2008 drilling.

The drill core was boxed at the drill rig and transported daily by helicopter to Northern Dynasty's (now the Partnership's) secure logging facility in Iliamna. A total of 12,664 samples were taken from the 72 drill holes. The 9,485 Cretaceous samples averaged 10 ft in length and the 3,179 Tertiary samples averaged 20 ft in length. The Cretaceous samples were taken by sawing the core in half lengthwise and the Tertiary samples were of the 20% off-centre saw type.

The average core recovery was 99.7%.

## 12.8 THE PEBBLE PARTNERSHIP 2008 DRILLING

---

Drill contractors American Recon, Boart Longyear and Foundex completed 234 NQ, HQ and PQ diameter holes for a total of 179,276 ft (54,643V m) on behalf of the Pebble Partnership in 2008.

The hole numbering sequence for 2008 is 8401 through 8444, including 7386, 7387, 7394 and 7394W, which were started in 2007 and completed in 2008. Pebble East drill hole 8436 was cored to a depth of 1,094 m (3,591 ft) in 2008 and may be re-entered in future. Thirty-one holes from this series were completed for delineation, infill and geotechnical purposes in Pebble East and one hole, 8444, was drilled in Pebble West. Fifteen PQ sized holes were drilled on Pebble West metallurgical targets. Foundex completed 105 geotechnical core holes numbered GH08- 107 through GH08-210, 17 in Pebble East and the remaining 88 in other areas of the property. In addition, in 2008, Foundex drilled 82 hydrogeology rotary percussion holes for a total of 6,747 ft (2,056 m).

A total of 12,701 samples were taken in 2008 by the Pebble Partnership. The 9,312 Cretaceous samples averaged 10 ft in length and the 3,389 Tertiary samples averaged 20 ft in length. The Cretaceous samples were taken by sawing the core in half lengthwise. Tertiary samples and assay samples from metallurgical holes were taken by the 20% off-centre saw method. The remaining 80% of the core from the Cretaceous portions of the metallurgical holes were used for metallurgical testing.

The core was boxed at the drill rig and transported daily by helicopter to the secure logging facility in Iliamna. The half core remaining after sampling is stored in a secure facility at Iliamna. Coarse rejects of Cretaceous and Tertiary rocks from the 2004 through 2008 drill program are stored in locked steel shipping containers at Allwest Freight in Delta Junction, AK. Some coarse rejects have been removed for check assaying and for the purposes of creating matrix matched certified reference materials (assay standards). The large 1.7 to 2.2 lb (750 to 1,000 g) Cretaceous rock assay pulps and the 0.5 lb (250 g) Tertiary waste rock pulps from these years are stored in a secure warehouse at Port Kells, BC.

Seven drill holes were completed by Full Metal Minerals in the Pebble district in 2008. Information for these holes, including assay results from 120 samples, is currently being integrated with the Pebble dataset.

## 12.9 THE PEBBLE PARTNERSHIP 2009 DRILLING

---

The drill contractor American Recon completed 33 NQ, HQ and PQ diameter holes for a total of 34,948 ft (10,652 m) on behalf of the Pebble Partnership in 2009. The hole numbering sequence for 2009 is 9445 through 9477. Holes 9445 to 9451 are condemnation holes drilled south of the Pebble deposit. Holes 9452 to 9454, 9457 and 9459 are delineation holes drilled around the margin of Pebble West. Holes 9455, 9456, 9458, and 9460 through 9477 are exploration holes drilled outside the Pebble deposit. Most of the holes were drilled vertically except for holes 9445, 9447, 9450, 9461, 9464, 9471, 9477, which were drilled at angles of -65° to -80°.

A total of 2,835 mainstream samples (including duplicate samples) were taken in 2009. The 2,555 Cretaceous samples averaged 10 ft in length and the 280 Tertiary samples averaged 20 ft in length. The

Cretaceous samples were taken by sawing the core in half lengthwise. Tertiary samples were taken by the 20% off-centre saw method.

The core was boxed at the drill rig and transported daily by helicopter to the secure logging facility in Iliamna. The half core remaining after sampling is stored in a secure facility at Iliamna. Coarse rejects of Cretaceous and Tertiary rocks from 2009 drill program are stored in locked steel shipping containers at Allwest Freight in Delta Junction, AK.

## 12.10 THE PEBBLE PARTNERSHIP 2010 DRILLING

---

Drill contractors American Recon and Foundex completed 66 NQ and HQ diameter holes for a total of 57,011 ft (17,377 m) on behalf of the Pebble Partnership in 2010. The hole numbering sequences for 2010 are 10478 through 10525 for the district exploration holes and GH10-211 through GH-228 for the geotechnical series. All holes were drilled vertically except 10520, which was inclined at  $-82^{\circ}$  at an azimuth of  $309^{\circ}$ , and GH10-225, which was drilled at  $-65^{\circ}$  and an azimuth of  $325^{\circ}$ .

A total of 4,714 mainstream samples were taken in 2010. The 4,463 Cretaceous samples and the 251 Tertiary samples averaged 10 ft in length. All samples were taken by sawing the core in half lengthwise.

The core was boxed at the drill rig and transported daily by helicopter to the secure logging facility in Iliamna. The half core remaining after sampling is stored in a secure facility at Iliamna. Coarse rejects of Cretaceous and Tertiary rocks from 2010 drill program are stored in locked steel shipping containers at Allwest Freight in Delta Junction, AK.

## 13.0 SAMPLE PREPARATION, ANALYSES AND SECURITY

---

Essentially all of the potentially mineralized Cretaceous rock recovered by drilling on the Pebble Project is subject to sample preparation and assay analysis for copper, gold, molybdenum and a number of other elements. Similarly, all Late Cretaceous to Early Tertiary cover sequence (Tertiary) rock cored and recovered during the drill program is also subject to sample preparation and geochemical analysis by multi-element methods.

Since 2007, all sampling at Pebble has been undertaken by employees or contractors, who are or are under the supervision of a qualified person, employed by the Pebble Partnership. No employee, officer, director or associate of Northern Dynasty was involved in the sample preparation. Wardrop has reviewed the sample preparation, security and analytical procedures for the Pebble Project and believes these processes are acceptable for use in geological and resource modelling for the Pebble deposit.

### 13.1 SAMPLE PREPARATION

---

Prior to 2001, all soil and drill core samples taken from the property were collected by Cominco personnel and sent to well-recognized laboratories. Samples prior to the 1997 program were prepared and analyzed by ALS Minerals (ALS) Laboratories in North Vancouver, BC. The 1997 drill core samples were prepared by ALS Laboratories in Anchorage.

The core samples were processed by drying, weighing, crushing to 70% passing 10 mesh (2 mm) and then splitting to a 250 grams sub-sample and a coarse reject; the 250 grams sub-sample was pulverized to 85% passing 200 mesh (75 µm).

In 2002, the samples were prepared at the Fairbanks laboratory of ALS. The sample bags were verified against the numbers listed on the shipment notice. The entire sample of half-core was dried, weighed and crushed to 70% passing 10 mesh (2 mm), then a 250 grams split was taken and pulverized to 85% passing 200 mesh (75 µm). The pulp was split, and approximately 125 grams was shipped by commercial airfreight for analysis at the ALS laboratory in North Vancouver. The remaining pulps were shipped to the secure Northern Dynasty warehouse at Port Kells for long-term storage. The coarse rejects were held for several months at the Fairbanks laboratory until all QA/QC measures were completed and were then discarded.

The 2003 samples were prepared at the SGS Mineral Services (SGS) sample preparation laboratory in Fairbanks. After verification of the sample bag numbers against the shipment notice, the entire sample of half-core was dried, weighed and crushed to 75% passing 10 mesh (2 mm). A 400-gram split was taken and pulverized to 95% passing 200 mesh (75 µm) and the pulp was shipped by commercial airfreight to the SGS laboratories in Toronto, ON, and Rouyn, QC. The assay pulps were returned to Northern Dynasty for storage at the Port Kells warehouse. Coarse rejects were held for several months at the Fairbanks laboratory until all QA/QC measures were completed and were then discarded.

For the 2004 through 2010 drill programs, the ALS sample preparation laboratory in Fairbanks performed the sample preparation work. The laboratory received the half core Cretaceous samples and the off-centre saw splits from the Tertiary samples and metallurgical holes, verified the sample numbers against the sample shipment notice and performed the sample drying, weighing, crushing and splitting. ALS of North Vancouver pulverized the samples from 2004 through 2006 and ALS Fairbanks pulverized the samples from 2007 through 2010.

## 13.2 ANALYSIS

---

Cominco systematically assayed all core for gold from the Cretaceous sections of the 125 drill holes they completed on the Pebble project from 1988 through 1997. Copper analysis was added when the Pebble porphyry discovery hole 004 was drilled in 1989 and single element copper analysis continued for all Cretaceous sections in 1989. Selective single element molybdenum assays were added for hole 006 in 1989, and from hole 011 to hole 014 of that year, molybdenum analyses were performed on the entire Cretaceous section. Single element silver analysis was performed on holes 001 through 014 as well. In 1990, Cominco added multi-element analysis, which included the determination of copper, molybdenum, silver and 29 additional elements, to the analytical protocol starting with hole 015. Multi-element analysis of all Cretaceous cores continued to hole 101 in 1992. Single element copper, molybdenum and silver analysis was dropped in favour of the multi-element method in 1990 and single element copper assaying resumed for 1991 and 1992. Only four holes were drilled by Cominco in 1993. These targets well south of the Pebble porphyry were only assayed for gold and copper.

In the 1997 program, a 250 grams pulp sample was submitted to Cominco's Exploration and Research Laboratory in Vancouver, BC, for copper analysis using an Aqua Regia digestion with inductively coupled plasma atomic emission spectroscopy (ICP-AES) finish. Gold was analyzed using Fire Assay (FA) on a one assay ton sample with atomic absorption spectroscopy (AAS) finish. Trace elements also were analyzed by Aqua Regia (AR) digestion and ICP-AES finish. One blind standard was inserted for every 20 samples analyzed. One duplicate sample was taken for every 10 samples analyzed.

ALS of North Vancouver, BC, an ISO 9002 certified laboratory, performed the analytical work for the 2002 program. All 2,467 samples were analyzed by fire assay for gold, and for 34 elements, including copper and molybdenum using a standard multi-element geochemical method. In addition, several drill holes exhibiting copper-gold porphyry style mineralization were subjected to copper assay level determinations. A few molybdenum assay level determinations were also performed. Gold concentration was determined by 30 grams FA fusion with lead as a collector and AAS finish. The four samples that returned gold results greater than 10,000 ppb (10 g/t), were re-analyzed by one assay ton FA fusion with a gravimetric finish. All samples were subject to multi-element analysis for 34 elements, including copper and molybdenum, by AR digestion with an ICP-AES finish. A total of 1,822 samples from 31 drill holes exhibiting porphyry copper-gold style mineralization were assayed for copper by four-acid (total) digestion with an AAS finish to the ppm level.

For copper assays greater than 10,000 ppm another total digestion with an AAS finish analysis was performed to the percent level. A further 61 samples from drill hole 2034 were assayed for molybdenum by four-acid digestion with an AAS finish to the ppm level.



SGS Canada Inc. of Toronto, ON, an ISO 9002 registered ISO 17025 accredited laboratory, performed the analytical work for the 2003 drill program. All 6,444 samples were analyzed by FA for gold, and for 33 elements, including copper and molybdenum, using a standard multi-element geochemical method. Gold concentration was determined at SGS Rouyn, QC, by one assay ton (30 grams) lead-collection FA fusion with AAS finish, with results reported in ppb. Ten samples which returned gold results >2,000 ppb (2 g/t) were re-analyzed by 30 grams FA fusion with a gravimetric finish, with results reported in grams per tonne.

Copper assays were done at SGS Toronto, ON. Samples were fused with sodium peroxide, digested in dilute nitric acid and the solution analyzed by ICP-AES, with results reported in percent. All samples were subject to multi-element analysis for 33 elements including copper, molybdenum and sulphur by AR digestion with an ICP-AES finish at SGS Toronto. In addition, 30 samples were analyzed by lithium metaborate fusion XRF finish whole rock analysis. All duplicates were analyzed at ALS laboratory in North Vancouver, BC.

From 2004 to 2010, total copper and molybdenum concentration was determined by an intermediate grade multi-element analytical method. A four-acid digestion was followed by ICP-AES finish (ALS method code ME-ICP61a). The same multi-element method was used to determine 23 additional elements, including sulphur. In 2004 and 2005, approximately one sample in 10 was also analyzed for copper by a high grade, four-acid digestion method with AAS finish (ALS code Cu-AA62). Beginning in 2004 for Tertiary rock and 2007 for Cretaceous rock, samples were analyzed for 47 elements by Four Acid digestion followed by inductively coupled plasma-mass spectroscopy finish (ICP-MS) and for mercury (Hg) by Cold Vapour AAS by ALS method ME-MS61m. Gold content was determined by 30 grams lead collection FA fusion with AAS finish (ALS method Au-AA23). A total of 10 samples from this period returned gold values greater than 10 ppm; they were re-analyzed by 30 grams FA fusion with a gravimetric finish (ALS method Au-GRA21), with results reported in ppm. From drill hole 7371 onward, gold concentration, along with platinum and palladium concentration, was determined by 30 grams FA fusion with ICP-AES finish (ALS method PGM-ICP23).

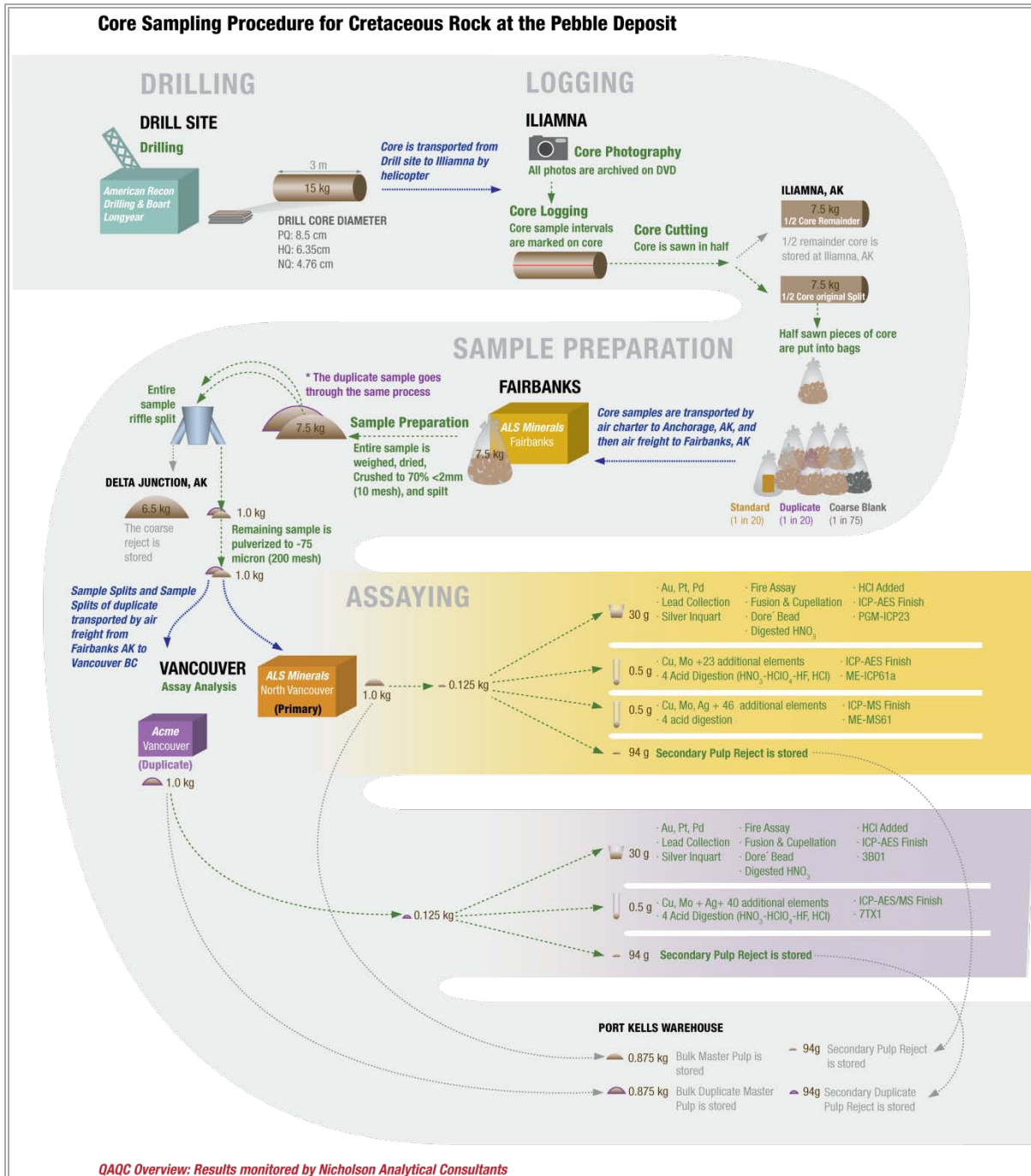
A total of 5,633 samples were subject to copper speciation analyses that included oxide copper analysis by citric acid leach AAS finish, non-sulphide copper analysis by 10% sulphuric acid leach AAS finish, and cyanide leachable copper on the sample residue of the sulphuric acid leach by cyanide leach AAS finish (ALS codes Cu-AA04, Cu-AA05 and Cu-AA17). A total of 222 samples from Pebble East drill hole 7359 were analyzed for precious metals (modified ALS method Au-SCR21 to include platinum and palladium). A 1,000 grams pulp sample was screened a 100 µm (Tyler 150 mesh) and the entire plus fraction was weighed and analyzed by FA ICP finish and two 30 grams minus fractions.

All duplicates since 2004 have been analyzed at Acme Analytical Laboratories (Acme) in Vancouver, BC, using similar methods. Acme method Group 7TD, a four-acid digestion with ICP-AES finish was used to determine total copper, molybdenum and 20 additional elements.

Check assays for gold were determined by Acme Group 3B method, 30 grams FA fusion with ICP-AES finish. Figure 13.2.1 illustrates the sampling and analytical flowchart for the 2010 drill program.

In 2010, 115 till samples were taken for analysis at Acme in Vancouver. The samples were dried, sieved to 230 mesh (63 µm) and a 15 grams sub-sample digested in aqua regia and analyzed by ICP-MS (Acme Method 1Fo5).

Figure 13.2.1 Pebble Project 2010 Drill Core Sampling and Analytical Flow Chart



## 14.0 DATA VERIFICATION

Wardrop reviewed the data verification procedures that have been done by the Pebble Partnership and by third parties on behalf of the Pebble Partnership. Wardrop did not carry out independent data verification. However, based on its review of these processes and observations made during the site visit, Wardrop believes these procedures are consistent with industry best practice and acceptable for use in geological and resource modelling.

### 14.1 QUALITY ASSURANCE AND QUALITY CONTROL (QA/QC)

Northern Dynasty maintained an effective QA/QC system consistent with industry best practice and this has continued under the Pebble Partnership in 2007, 2008, 2009 and 2010. This program is in addition to the QA/QC procedures used internally by the analytical laboratories. The QA/QC program has been subject to independent review by Analytical Laboratory Consultants Ltd (ALC – 2004 to 2007) and Nicholson Analytical Consulting (NAC – 2008 to 2010). The analytical consultants provide ongoing monitoring, including facility inspection, and timely reporting of the performance of standards, blanks and duplicates in the drill hole sampling and analytical program. The results of this program indicate that analytical results are of a high quality suitable for use in detailed modelling and resource evaluation studies.

Table 14.1.1 describes the QA/QC sample types used in this program. The performance of the copper-gold standard CGS-16 is illustrated in Figure 14.1.1 and Figure 14.1.2. A comparison of the matched-pair duplicate assay results of ALS and Acme for 2004 through 2008 is provided in Figure 14.1.3 and Figure 14.1.3

**Table 14.1.1 QA/QC Sample Types Used**

QC Code	Sample Type	Description	Percent of Total
MS	Regular Mainstream	<ul style="list-style-type: none"> <li>Regular samples submitted for preparation and analysis at the primary laboratory.</li> </ul>	90%
ST	Standard (Certified Reference Material)	<ul style="list-style-type: none"> <li>Mineralized material in pulverized form with a known concentration and distribution of element(s) of interest.</li> <li>Randomly inserted using pre-numbered sample tags.</li> </ul>	4% or 1 in 25
DP	Duplicate or Replicate	<ul style="list-style-type: none"> <li>An additional split taken from the remaining pulp reject, coarse reject, ¼ core or ½ core remainder.</li> <li>Random selection using pre-numbered sample tags.</li> </ul>	5% or 1 in 20
SD	Standard Duplicate	<ul style="list-style-type: none"> <li>Standard reference sample submitted with duplicates and replicates to the check laboratory.</li> </ul>	<1%
BL	Blank	<ul style="list-style-type: none"> <li>Basically a standard with no appreciable grade used to test for contamination.</li> </ul>	1%

Figure 14.1.1 Performance of the Copper Standard CGS-16 in 2008

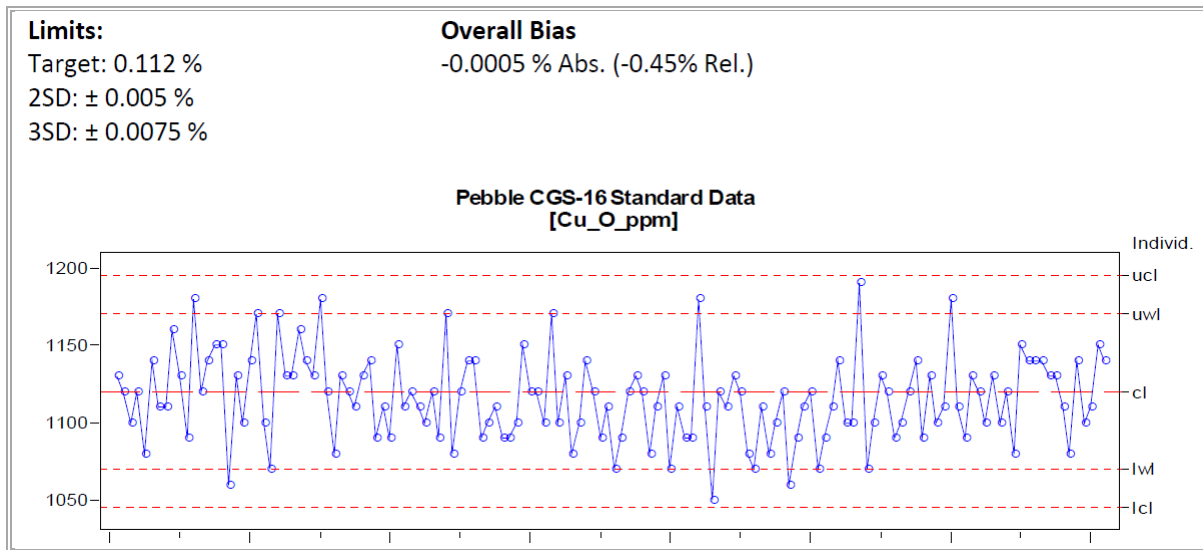
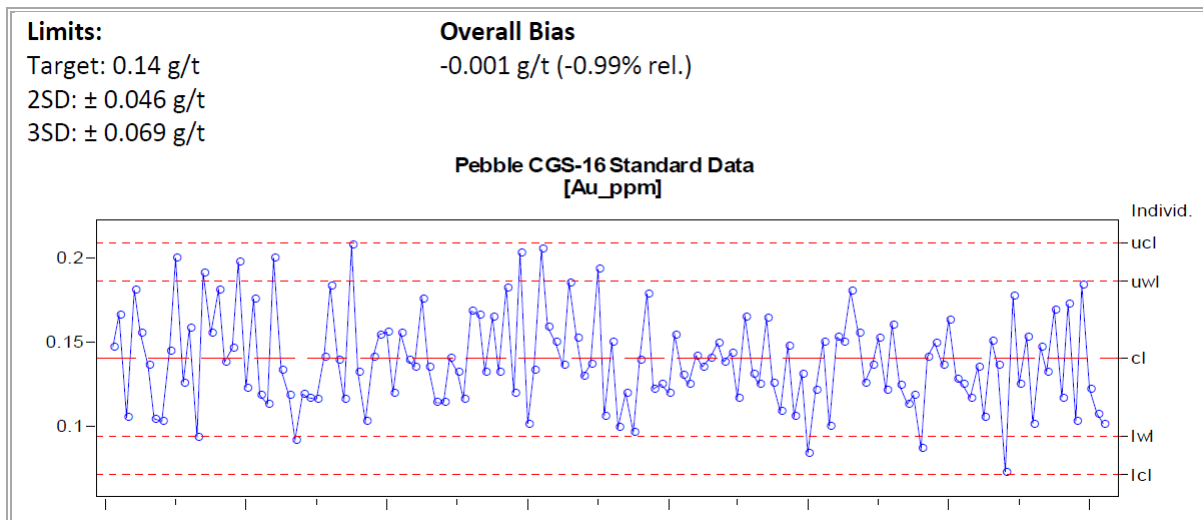


Figure 14.1.2 Performance of the Gold Standard CGS-16 in 2008



### 14.1.1 STANDARDS

Standard reference materials were inserted into the Cretaceous sample stream (approximately 1 sample for every 20) after sample preparation as anonymous (blind), consecutively-numbered pulps. These standards are in addition to those routinely analyzed by the analytical laboratories themselves. Standards were inserted in the field by the use of sample tags, on which the "ST" designation for "Standard" was pre-marked. For the Tertiary waste rock analytical program, coarse blanks were inserted at the sample tags positions marked as ST until late 2008, when a commercial pulp blank was used.

Standard performance was monitored by charting the analytical results over time against the concentration of the control elements. The results are compared with the expected value and range, as determined by round-robin analysis. A total of 28 different standard reference materials were used to monitor the assay results from through 1997 to 2010.

In December 2007, several tons of drill core coarse reject samples from Pebble East and Pebble West were pulled from storage and shipped to Ore Research & Exploration Pty Ltd in Melbourne, Australia for the production of ten matrix-matched certified reference materials. These standards (Pebble Partnership-1 through Pebble Partnership-10) became available in late 2009 and have been used to monitor the Pebble analytical results since then. Nine of the standards from Cretaceous rock are certified for gold, copper, molybdenum, silver, and arsenic. One standard (Pebble Partnership-2) is from Tertiary rock and is certified for copper, molybdenum, arsenic, silver, and mercury.

Copper and gold standards were inserted in the 1997 and the 2002 through 2008 programs. Molybdenum standards were added in September 2008. A standard determination outside the control limits indicates a control failure. The control limits used are as follows:

- warning limits:  $\pm 2$  S.D; and
- control limits:  $\pm 3$  S.D.

When a control failure occurred, the laboratory was notified and the affected range of samples re-analyzed. By the end of the program, no sample intervals had outstanding QA/QC issues. The standard monitoring program provides a good indication of the overall accuracy of the analytical results.

#### 14.1.2     **DUPLICATES**

Random duplicate samples were selected and tagged in the field by the use of sample tags on which the DP designation for duplicate was pre-marked. A total of 4,541 duplicate samples (including DP samples and SD samples) were taken since 1989 for inter-laboratory (or intra-laboratory) duplicate analysis. From 2004 onward, samples to be duplicated were split by ALS at Fairbanks and submitted to Acme in Vancouver for pulverization.

The original samples were assayed by ALS of North Vancouver and the corresponding duplicate samples were assayed by Acme of Vancouver. The approximately 2,000 coarse reject, inter-laboratory duplicate assay results from 2004 to 2010 match well; the correlation coefficients are 0.96 for gold, 0.98 for copper and 0.98 for molybdenum.

Figure 14.1.3 and Figure 14.1.4 provide a comparison of the matched-pair duplicate assay results of ALS and Acme for 2004 through 2008.

Figure 14.1.3 Comparison of Gold Duplicate Assay Results for 2004-2010

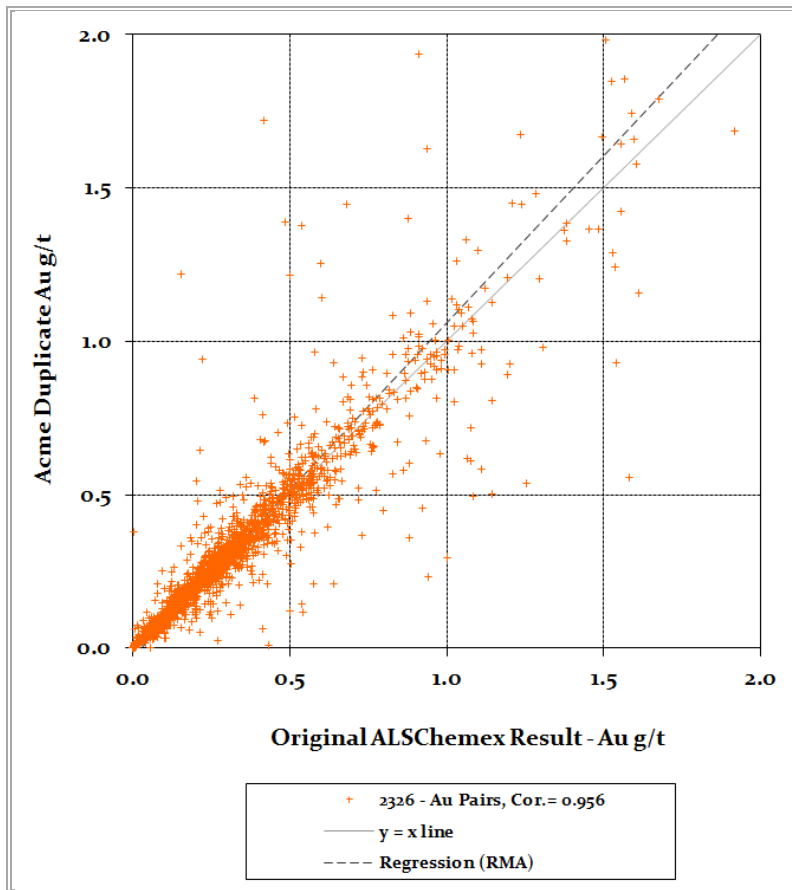
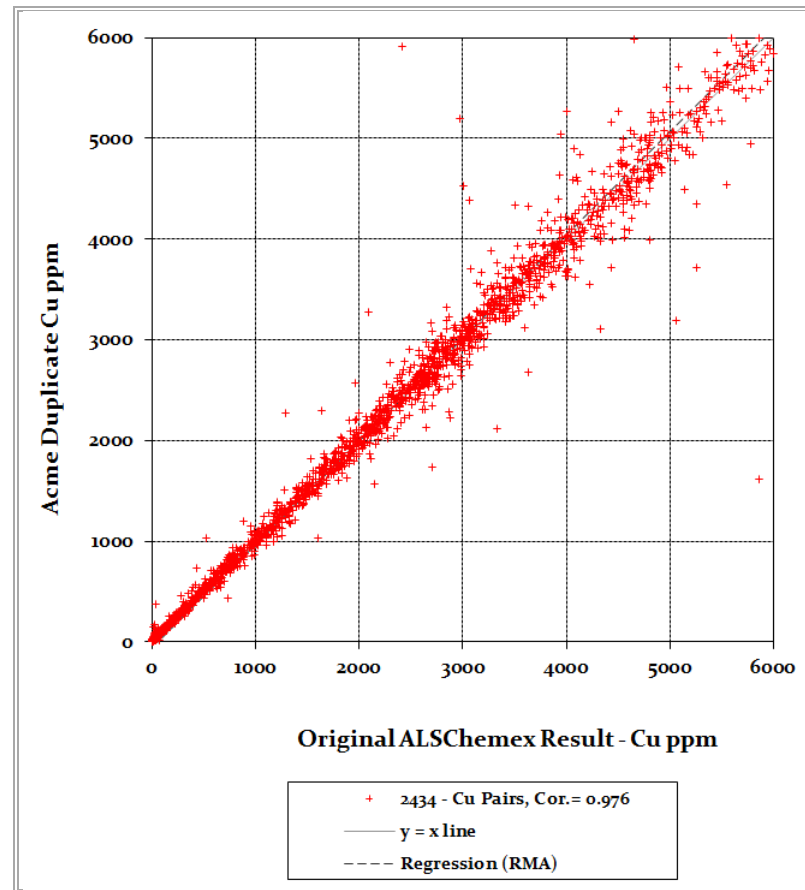


Figure 14.1.4 Comparison of Copper Duplicate Assay Results for 2005-2010



### 14.1.3 BLANKS

A total of 1,091 field blanks have been inserted since 2004 to test for contamination. This is in addition to the analytical blanks routinely inserted with the samples by the assay laboratories as a part of their internal quality control procedures. In 2004, coarse landscape dolomite was inserted as a blank material. This material was replaced by gravel landscape material between 2005 and late 2008. In late 2008, (drill hole 8442), the gravel blank was replaced by a quarried grey granitic landscape rock. This material has a lithological matrix similar to the Pebble Cretaceous host rocks.

About 1 lb (0.5 kg) of the blank was placed in a sample bag, given a sequential sample number in the sequence and randomly inserted one to six times per drill hole after the regular core samples were split at Iliamna. These blank samples were processed in sample number order along with the regular samples.

Of the 1,091 blanks inserted, 444 were included in the Tertiary waste rock sample program in the position marked for the standard. In late 2008, a commercial precious metals pulp blank was inserted with the Tertiary waste rock samples. In late 2009, the use of matrix-matched Tertiary standard Pebble Partnership-2 was initiated.

The majority of assay results for the blanks report at or below the detection limit. The maximum values reported are: gold 0.028 g/t and copper 0.057% in the current results. No significant contamination occurred during sample preparation, with a few minor exceptions, likely due to cross sample mixing errors during crushing.

### 14.1.4 QA/QC ON OTHER ELEMENTS

The four-acid digestion ICP-AES 25 multi-element analytical method employed from 2004 through 2008 is optimized for copper and molybdenum analysis. The copper and molybdenum assays were monitored by laboratory internal and Northern Dynasty or Pebble Partnership external standards.

Twenty three additional elements including (with their lower detection limits): silver (1 ppm), aluminum (0.05%), arsenic (50 ppm), barium (500 ppm), beryllium (10 ppm), bismuth (20 ppm), calcium (0.05%), cadmium (10 ppm), cobalt (20 ppm), chromium (10 ppm), iron (0.05%), potassium (0.1%), magnesium (0.05%), manganese (10 ppm), sodium (0.05%), nickel (10 ppm), lead (20 ppm), sulphur (0.1%), antimony (50 ppm), strontium (10 ppm), titanium (0.05%), vanadium (10 ppm) and zinc (20 ppm) were also determined by this multi-element method.

Parallel to this method, ICP-MS 48 multi-element method was also used to determine the same 25 elements above and 23 additional elements. The ICP-MS method gives lower detection limits for most of the trace elements.

## 14.2 SPECIFIC GRAVITY (BULK DENSITY) DETERMINATIONS

---

Density measurements were made at 100 ft (30 m) intervals within continuous rock units, and at least once in each rock unit less than 100 feet in width. Rocks chosen for analysis were typical of the

surrounding rock. Where the sample interval occurred in a section of missing core, or poorly consolidated material unsuitable for measurement, the nearest intact piece of core was measured instead.

Core samples free of visible moisture were selected; they ranged from 3" to 12" (8 to 30 cm) in length, and averaged 10 cm. The samples were dried, weighed in air on a digital scale (capacity 4.4 lb or 2,000 g) and the mass in air (Ma) recorded to the nearest 0.1 grams. The sample was then suspended in water below the scale and the mass in water (Mw) entered into the same table. Calculation of the density was by the following formula:

$$\text{Density} = \text{Ma} / (\text{Ma} - \text{Mw})$$

Core-sized pieces of aluminum were used as density standards at site starting in 2008. A total of 9,951 density measurements of Tertiary and Cretaceous rocks were taken using a water immersion method on whole and half drill core samples at the Iliamna core logging facility.

Table 14.2.1 is a summary of these results. Table 14.2.2 is a summary of the results for the holes used for resource estimation.

**Table 14.2.1 Summary of All Density Results**

Age	No. Measurements	Density Mean	Density Median
Quaternary	11	2.58	2.62
Tertiary	2,590	2.56	2.57
Cretaceous	6,153	2.64	2.62
<b>All</b>	<b>8,754</b>	<b>2.61</b>	<b>2.61</b>

**Table 14.2.2 Summary of All Density Results Used for Resource Estimation**

Age	No. Measurements	Density Mean	Density Median
Quaternary	7	2.56	2.62
Tertiary	1,674	2.57	2.58
Cretaceous	4,173	2.63	2.61
<b>All</b>	<b>5,854</b>	<b>2.61</b>	<b>2.61</b>

#### 14.2.1 DENSITY VALIDATION

The density data were reviewed prior to the July 2008 resource estimation. The following types of errors were noted: entry errors, standards labelled as regular samples, incorrectly calculated density values based on the Ma and Mw values entered, and extremely high or low density values without appropriate explanation. These errors were corrected prior to including the data for the resource estimate.



Two other possible sources of error in the measurements were identified, the presence of moisture in the  $M_a$  measurement for some samples, and the presence of porosity and permeability of the bulk rock mass not determinable by the method.

The former will result in measurements that are somewhat overstated, and the latter in measurements that are understated in terms of the dry in-situ bulk density.

It is recommended that additional drying and wax coating tests be performed in a laboratory under controlled conditions on a variety of samples already tested by the water immersion method. In addition, several samples of cut cylinders of core should be included with these tests, the dimensions of which can be accurately measured so their volumes can be calculated directly.

It is also recommended that the bulk in-situ porosity and permeability of the rock mass be determined by geotechnical testing.

### 14.3 SURVEY VALIDATION

---

In 1988, Cominco established a survey control network including the *Pebble Beach* base monument in the deposit area using US State Plane Coordinate System Alaska Zone 5 NAVD88 Geoid03. This monument was tied to the NGS State Monuments at Iliamna and formed the base for subsequent drill collar surveys. In 2004, air photo panels and a control network were established using US State Plane Coordinate System Alaska Zone 5 with elevations corrected to NAVD88 based on Geoid99. However, the *Pebble Beach* base monument was not tied into the 2004 control network.

In 2005, differences between the elevations of surveyed drill collars in the deposit area and the digital elevation model (DEM) topography were observed. In early 2008, a resurvey program was initiated to investigate and resolve these discrepancies for holes used in resource modelling. A consistent error was identified in the collar coordinates from some years and questions arose as to whether drill collars had been surveyed to the top of the drill casing or to ground level. In September 2008, two new control points were established in the deposit area, *Pebble 1* and *Pebble 2*. These two points and the *Pebble Beach* monument were tied into the 2004 control network and an x, y, z linear coordinate correction was developed to correct data previously based on *Pebble Beach*.

During the 2008 and 2009 field seasons, all holes drilled at the *Pebble Project* since inception in 1988 were resurveyed to gain a complete set of consistently acquired collar survey data. The majority of the drill holes were marked with a wooden post and an aluminum tag. In cases where the post was missing, the original coordinates were used to find evidence of the drill hole. Any hole missing a drill post was remarked and this was noted in the database. The re-surveys were taken to the top of tundra over the centre of the drill hole. Where a drill hole could not be located, the resurveyed coordinate was taken at the original drill collar location and the elevation re-established in the new system.

## 14.4 DATA ENVIRONMENT

All drill logs and surface exploration samples collected on the project site are compiled in a Microsoft® Access (Access) relational database which has tables that are compatible with Gemcom GEMS™ mining exploration software.

Drill hole logs are entered into notebook computers running the Access data entry module for the Pebble Project at the core shack in Iliamna. The core logging computers are synchronized on a daily basis with the master site entry database on the file server in the Iliamna geology office.

Core photographs are also transferred to the file server in the Iliamna geology office on a daily basis. In the geology office, the logs are printed, reviewed and validated and initial corrections made.

The site data is transmitted on a weekly basis to the Vancouver office where the logging data are imported into the master drill database and merged with digital assay results provided by the analytical laboratories. A further printing, validation and verification step follows after import.

Log corrections are submitted to the Iliamna office for correction. Analytical re-runs and are submitted to the analytical laboratories and corrections to analytical results within the database are made in the Vancouver office. In parallel to this, the independent analytical QA/QC consultant compiles sample log data from the site with assay data received directly from the laboratories as part of the ongoing monitoring process. Compiled data are exported to the site entry database, to resource modelling and other users.

Table 14.4.1 summarizes the drilling information compiled in the primary database for the Project.

**Table 14.4.1 Drill Hole Database Summary**

Year	Drill Holes	Feet Drilled	Metres Drilled	Core Samples	Operator
1988	26	7,602	2,317	626	Cominco
1989	27	7,422	2,262	796	
1990	25	10,021	3,054	965	
1991	48	28,129	8,574	2,674	
1992	14	6,609	2,014	611	
1993	4	1,263	385	100	
1997	20	14,696	4,479	1,215	
2002	68	37,237	11,350	2,467	Northern Dynasty
2003	67	71,227	21,710	6,444	
2004	266	165,481	50,439	13,769	
2005	114	81,979	24,987	5,813	
2006	47	72,622	22,135	4,606	
2007	92	167,667	51,105	12,664	
2008	241	184,726	56,305	12,821	Northern Dynasty & Pebble Partnership Pebble Partnership <sup>1</sup>
2009	33	34,947	10,652	2,835	
2010	66	57,011	17,377	4,714	
<b>ALL</b>	<b>1,151</b>	<b>948,638</b>	<b>289,145</b>	<b>73,120</b>	

Note: 1. Includes 7 FMM holes drilled in 2008 and acquired in 2010.

Table 14.4.2 summarizes the drilling information in the primary database used for resource estimation.

**Table 14.4.2 Drill Hole Database Summary Used for Resource Estimation**

Year	Drill Holes	Feet Drilled	Metres Drilled	Core Samples	Operator
1988	2	554	169	79	Cominco
1989	9	3,130	954	467	
1990	24	9,813	2,991	941	
1991	48	28,130	8,574	2,674	
1992	14	6,608	2,014	611	
1993	-	-	-	-	
1997	20	14,695	4,479	1,215	Northern Dynasty
2002	17	6,522	1,988	301	
2003	59	65,423	19,941	6,138	
2004	173	152,543	46,495	13,518	
2005	28	72,533	22,108	5,641	
2006	17	68,048	20,741	4,528	
2007	43	161,473	49,217	12,399	
2008	47	153,724	46,855	11,710	Pebble Partnership
2009	8	9,429	2,874	835	
2010	-	-	-	-	
<b>ALL</b>	<b>509</b>	<b>752,625</b>	<b>229,400</b>	<b>61,057</b>	

#### 14.4.1 ERROR TRAPPING PROCESSES

Error trapping within the data entry module is used in the core shack and the Iliamna geology office as part of the data verification process. This program standardizes and documents the data entry, restricts data which can be entered and processed and enables corrections to be made at an early stage. Users are prompted to make selections from pick-lists where appropriate, and other entries are restricted to reasonable ranges of input. In other instances, information must be entered and certain steps completed prior to advancing to the next step. After the logs have been entered, they are reviewed and validated by the logger and a copy printed out for the site files.

Site data are transmitted to the Pebble database compilation group on a weekly basis. Software validation routines are run to identify several types of errors. The compiled data from the header, survey, assay, geology and geotechnical tables are validated for missing, overlapping or duplicated intervals or sample numbers, and for matching drill hole lengths in each table. Drill hole collars and traces are viewed on plan view and in section by a geologist as a visual check on the validity of the location information.

As the analytical data are returned from the laboratory, they are merged with the sample logs, and then printed out, and the gold, copper, molybdenum and silver values of the regular samples and QA/QC samples are reviewed. Particular attention is paid to standards that have failed QA/QC as they are targeted for immediate review; re-runs are requested from the analytical laboratory if necessary.

#### 14.4.2 ANALYSIS HIERARCHIES

The first valid QA/QC-passed analytical result received from the primary laboratory has the highest priority in the analytical hierarchy, all other things being equal. If the same analytical method is used more than once, no averaging is done. If different analytical methods are employed on the same sample, the most appropriate combination of digestion and analytical method is selected and used.

For gold analysis, fire assays determined by gravimetric finish supersede results by AAS finish, particularly where the AAS results are designated as over-limits. For copper and molybdenum analysis done on Cretaceous rocks after 2004, ALS intermediate grade multi-element analytical method ME-ICP61a supersedes copper by low grade multi-element method ME-MS61m.

In the case of all other elements, including silver and sulphur analyses from 2007 and 2008, method ME-MS61m supersedes ME-ICP61a unless the ME-MS61m results are greater than the upper detection limit. In that case, the ME-ICP61a result prevails.

#### 14.4.3 WEDGES

Some long holes particularly in Pebble East were purposefully wedged when drilling conditions in the parent hole prevented them from reaching their target depth. For the purposes of geological and resource modelling, it is desirable that mother hole-wedge hole combinations be represented by singular linear traces in the database. In treating the wedged portion of a hole that successfully extends beyond its parent-hole, the following approach was used. The wedged portion of the hole was treated as a continuation of the mother hole from the point where the wedge starts. The information from the mother hole and the wedge was blended onto a string that follows the mother hole to the wedge point and then follows the wedge (and the wedge surveys) to the end of the hole. The "best available" information from the two hole strings was combined to produce one singular linear drill hole trace.

#### 14.4.4 CONTROL OF QA/QC

In the interests of timely disclosure of information to those involved in advancing the project, data are made available to the technical team for immediate use after the error trapping and initial review process is complete. However, at the time the data is made available, validation, verification and analytical QA/QC may still be in progress on recently-generated information. At the time the drill data was exported from the primary database for use in the current resource estimate, the results had been validated and all assay results had passed analytical QA/QC.

## 14.5 VERIFICATION

---

The 1997 and prior Cominco data were validated by Northern Dynasty in 2003 using:

- the digital data and printed information;
- digital assay results obtained directly from ALS and Cominco Exploration Research laboratories, where available; and
- selected re-analysis of the original assay pulps.

Most of the pre-2002 data in the current database is derived from a digital compilation created by Cominco in 1999. Twenty-eight gold results from 1988 and 1989 holes, which existed only on hand written drill logs, were added to the database. Although a complete set of original information does not exist for all the historical holes and, in particular, the printed assay certificates were not found, the digital data appear to be of good quality. The data compiled by Cominco matches the digital analytical data received directly from the laboratories, with few exceptions. Most differences are likely due to separately reported over-limits and reruns.

The small number of errors identified in the Cominco data, including mismatched assay data, conversion errors, unapplied over-limits and typographical errors were corrected.

The 2002 analytical data were also verified and validated. A few errors were identified and corrected. When the 2003 digital data were verified against the assay certificates, some differences with the printed certificates were identified. In 2003, the analytical results were provided by SGS laboratory in a digital format that included SGS internal standards, duplicates and blanks. These digital results differed from the values on the corresponding printed certificates in two ways; digits in excess of three significant figures were recorded and results were not trimmed to the upper detection limit value. arsenic a result, sixteen 2003 gold assays over 2000 ppb had incorrect values assigned to them in the database. This was corrected by applying the correct Fire Assay over-limit rerun result to these samples in the database. No over-limits existed in the 2003 copper results so there were no problems with this element. The lone over-limit molybdenum value (26,290 ppm for sample 242801 in hole 3097) was left untrimmed because this result was substantiated by an ALS check assay. Results from 2003 for elements other than gold, copper and molybdenum were left untrimmed in the database.

Norwest reported on additional data verification done in conjunction with the resource estimate in the February 20, 2004 report. "Norwest received, from Northern Dynasty, the initial Pebble drill hole database in the form of an assay, collar, downhole survey and geology file. An audit was undertaken of 5% of the data within these files. Digital files were compared to original assay certificates and survey records. It was determined that the downhole survey file had an unacceptable number of errors. . The assay file had an error rate of approximately 1.2%. This was considered acceptable for this level of study." These errors were subsequently corrected at Northern Dynasty.

The 2004 to 2010 drill hole data were collected and digitally entered by Northern Dynasty's, and subsequently the Pebble Partnership's geological and technical personnel at the Iliamna site and sent to the Vancouver office on a weekly basis. In Vancouver, the digital database was compiled, merged with the analytical results, and reviewed for QA/QC. Verification and validation took place at Iliamna

and Vancouver. At Iliamna, the geologist responsible for each drill hole reviewed print-outs of the digitally entered geology, sample and field log data.

The merged sample logs and analytical results were also reviewed by site personnel and, if necessary, checked against the drill core.

In Vancouver, the compiled data from the header, survey, assay, geology and geotechnical tables were validated for missing, overlapping or duplicated intervals or sample numbers, and for matching drill hole lengths in each table. Drill hole collars and traces were reviewed in plan and sectional view as a visual check on the validity of the location information by a geologist. Arsenic the analytical data were returned from the laboratory they were merged with the sample logs, printed out, and the gold, copper, molybdenum and silver values verified against the original assay certificates provided by the laboratory. Particular attention was paid to laboratory reruns where the analytical results were revised for QA/QC reasons to ensure the correct data were applied.

Verification and validation work were completed on the 2004 data by January 2005 and a low number of errors were reported. Erroneously labelled standards in the sample log were the main source of error. Digital values not matching the analytical certificates were the next area of concern. In this case, the digital data were usually correct, as the certificates had been superseded by new results from QA/QC reruns.

The 2005 through 2010 data were verified and validated at the Iliamna office and in the Vancouver office as the drill program progressed. The validation and verification work for each year was generally completed by January of the following year, although some QA/QC issues took longer to resolve. Work at the Iliamna office consisted mostly of validating the site data entry and resolving errors that were identified. Additional validation and verification work was performed in the Vancouver office. This consisted of checking the site data tables for missing, overlapping, unacceptable and mismatching entries, and reviewing the analytical QA/QC results.

In addition to this, the copper, gold and molybdenum data received on the ALS analytical certificates were manually verified against print-outs of the sample results from the database for intervals included in Northern Dynasty news releases.

This verification and validation work performed on the digital database indicates that it is of good quality and acceptable for use in geological and resource modelling of the Pebble deposit.

A significant amount of diligence and analytical QA/QC for copper, gold and molybdenum has been completed on the samples that were used in the January 2009 mineral resource estimate. This work indicates that the copper, gold and molybdenum analytical results are acceptable for use in geological and resource modelling of the Pebble deposit.

## 15.0 ADJACENT PROPERTIES

---

There are no properties adjacent to the Pebble Project relevant to this report.





## 16.0 MINERAL PROCESSING

---

### 16.1 OVERVIEW

---

Wardrop was commissioned to complete a NI 43-101-compliant Preliminary Assessment of the Pebble Project for Northern Dynasty Minerals Ltd. (Northern Dynasty).

Northern Dynasty provided information to Wardrop which contained the metallurgical testwork results and the process design prepared by AMEC Americas Ltd. (AMEC) for Northern Dynasty and Pebble Partnership, and was based on the AMEC interpretation of the results obtained from the various metallurgical investigations and consultants employed by the Pebble Partnership. This section of the Preliminary Assessment incorporates a review of the metallurgical testwork and a discussion of the process design criteria (PDC), the proposed flowsheet, and the process plant design. Simplified process flowsheets have been included in the review, together with a simplified mass balance.

Based on the review of the Northern Dynasty reports submitted to Wardrop, discussions and recommendations for the Preliminary Assessment will be presented throughout the report.

### 16.2 INTRODUCTION

---

The Pebble Partnership, which is owned equally by affiliates of Northern Dynasty and Anglo American plc, is proposing the mining and processing of 200,000 tons per day of a large porphyry copper, gold, molybdenum resource material located in Alaska, USA. The feed material to the process plant will contain copper minerals, primarily as chalcopyrite with minor bornite and chalcocite, associated gold content, and the molybdenum-bearing mineral molybdenite. The primary products of the process will be copper-gold and molybdenum concentrates. Gold will also be recovered as doré via a secondary recovery plant. Other valuable metals, namely silver, rhenium, and palladium, are also recoverable in the concentrates.

The feed to the plant is planned to have a nominal head grade of 0.50% Cu, 0.496 g/t Au, and 0.03% Mo. The metal recoveries were estimated to be as follows:

- A copper recovery of 86.1% with a concentrate grade of 26% Cu;
- A molybdenum recovery of 83.6% with a concentrate grade of 52% Mo; and
- A combined concentrate and doré gold recovery of 71.2%, with a grade of about 18 g/t Au in the copper concentrate.

### 16.3 MINERALOGY

---

The Pebble deposit mineralogy is typical of copper porphyry deposits in northwest North America. The principal sulphide minerals present are pyrite and chalcopyrite with minor bornite, chalcocite, and

molybdenite. Gold is associated with both the copper and pyrite mineralization. A small amount of gold is associated with the non-sulphide gangue minerals. Gold grain sizes of about 5 µm were found to be typical. Chalcocite-rimmed pyrite grains were observed and are recoverable into the copper concentrate.

The gangue minerals are predominantly quartz, feldspar, muscovite, sericite, biotite, plagioclase and clay minerals. A modal analysis indicated that the primary grinding of P<sub>80</sub> of 140 µm would support the liberation results obtained for the copper minerals. Utilizing these data, and the subsequent testwork results, an economic analysis has been conducted to ascertain the optimum grind size. On the basis of this work, a primary grind P<sub>80</sub> of 200 µm was selected.

The testwork conducted by SGS Lakefield Research Ltd. (SGS) has found the copper to sulphur ratio to be a reasonable guide to the metallurgical response with respect to copper recovery.

A mineralogical investigation to assess the deposit variability and to optimize the flowsheet has been conducted. This work utilized QEMSCAN analysis on 92 samples from different parts of the Pebble deposit. Different proportions of minerals were found in the different parts of the deposit and in the four major different rock types. The conclusions obtained by an evaluation of the mineralogical data confirm the flowsheet selection for the Pebble Project.

The various metallurgical test programs confirmed that the major copper mineral was chalcopyrite, with minor amount of bornite, covellite, chalcocite, enargite, tennantite, and native copper. The work also indicated that the required primary grind P<sub>80</sub> range top size was 130 µm for full liberation confirming the previously mineralogically determined liberation size. The regrind size was confirmed to be about 25 µm. The Pebble East samples indicated minimal clay content, and that gangue depressants would not be required in the flotation circuit. However, the mica content was found to be very high and it was considered to be possible that mica entrainment could adversely affect the molybdenum recovery and concentrate grade in particular.

A molybdenum grain size study indicated that the majority of the molybdenum is liberated at sizes below 150 µm and that fine regrinding below 20 µm ahead of the copper-molybdenum separation stage would not be beneficial. Molybdenum concentrate grades of 50% or better are considered to be readily attainable.

Two pyrite concentrates were analyzed for gold characterization. Gold was confirmed to be present as native gold with a purity analysis of between 94.7 and 96% Au. The grains also contained 2.6 and 7.8% Ag and between 1.7 and 2.2% Fe, with most of other elements being below detection limit. For the concentrate grain size of about 15 µm, 87% of the gold in the Pebble East pyrite concentrate sample was found to be liberated, and the equivalent number was 51% for the Pebble West sample. The Pebble East sample indicated 20% of the gold to be associated and/or locked in sulphide minerals (mainly pyrite); while, for Pebble West, the figure was 49%. Sub-microscopic, colloidal and solid solution gold was found in the sulphide grains present in the pyrite concentrate. The majority of the colloidal and solid solution gold would not be extractable and would explain the gold losses observed from leach tests.

**Table 16.3.1 Gold Department in Pyrite Concentrates**

Sample ID	Microscopic			Submicroscopic	
	Liberated (%)	Attached (%)	Locked (%)	Colloidal Size (%)	Solid Solution (%)
Pebble West Hypogene Pyrite Concentrate	2.7	2.5	20.8	70	4
Pebble East Pyrite Concentrate	1.7	0.7	31.6	42	24

A gold deportment study was conducted on a bulk cleaner scavenger tailings sample originating from testwork from material from the Pebble West deposit. Mineralogically, the sample was composed of 45% pyrite and 55% non-sulphide gangue. No liberated or coarse locked gold particles were identified and it was found that approximately 20% of the gold was present as solid solution gold in pyrite grains. The remaining gold (approximately 80%) was assumed to be present as ultrafine inclusions (<0.5 µm), with 45% of the gold being recoverable under intensive leach conditions. These conclusions were supported by the 39% Au recovery obtained for this sample under normal leach conditions.

Six bulk cleaner scavenger tailings samples from the Pebble deposit as a mixed Pebble East and Pebble West sample mineralization test program were also studied to determine the bulk mineralogy and the nature and carriers of gold. The products were generated in the flotation locked cycle tests. The comprehensive investigation included mineralogical, metallurgical processing, and analytical analyses including fire assay, X-ray diffraction, Wilfley tabling, heavy liquid separation, super-panning, ore microscopy, and scanning electron microscope analysis.

The results of the gold deportment study are presented in Table 16.3.2. In contrast with the results from the Pebble West study, the gold grain sizes identified ranged from 0.5 to 8.0 µm and occurred mainly as fine inclusions in sulphide minerals, primarily in pyrite and chalcopyrite, except for one liberated gold grain observed in the bulk cleaner scavenger tailings with a gold grain size of 40 x 30 µm, and one gold grain with a grain size of 250 x 30 µm. In all the samples investigated, the gold occurred primarily as native gold.

**Table 16.3.2 Summary of Gold Grains Observed in the Six Cleaner Scavenger Tailings Samples**

Sample ID	Microscopic Gold Grain					Gold Species	
	No. Liberated	No. Attached	No. Locked	Total No.	Size (µm)	Au (Wt %)	Gold Minerals
PBA Sc Tail	1	0	6	7	15	93.1	Native Gold
PBB Sc Tail	0	0	6	6	2	91.9	Native Gold, Electrum
PBC Sc Tail	0	1	12	13	2	96.4	Native Gold, Electrum
PBD Sc Tail	1	0	9	10	6	97.3	Native Gold
PBE Sc Tail	0	1	4	5	2	72.4	Native Gold, Native Silver
PBF Sc Tail	0	0	8	8	1.6	85.0	Native Gold, Native Silver

The mineralogical evaluations have generally confirmed that acceptable metal recovery values will be obtained for primary grind sizes in the range 140 to 200 µm.

The mineralogical associations and size analysis have provided a consistent basis for understanding the behaviour of the copper minerals during the flotation process, and the losses to the tailings.

The evaluation of the occurrence of gold particles has confirmed that the gold is extremely fine-grained and confirmed the presence of colloidal and solid-solution gold present in the host mineral.

It is recommended that a mineral fragmentation distribution table (modal analysis) giving the liberated grains, binaries with sulphide minerals, binaries with non-sulphide gangue, and composites, be established.

Rhenium has been reported to occur in economic quantities in the final molybdenum concentrate produced. It will be assumed that the rhenium present in the molybdenum concentrate is present in solid solution within the molybdenite crystal structure, which is the commonly accepted occurrence. However, mineralogical investigative work should be conducted to qualify this assumption.

## 16.4 METALLURGICAL TESTWORK DISCUSSION

Initial metallurgical testing was conducted during 2003 and this has continued through to the present. Test facilities employed over the years included:

- Process Research Associates, Vancouver, BC;
- G&T Metallurgical Laboratories, Kamloops, BC; and
- SGS Lakefield Research Ltd., Lakefield, ON.

The criteria used for the design of the processing facilities for the Pebble Project are based on the results obtained from the testwork conducted at these and other laboratories. Various aspects of the metallurgical test program will be discussed in this section.

### 16.4.1 PLANT FEED GRADE

The feed grade data derived from the 25-year IDC mine plan are provided in Table 16.4.1.

**Table 16.4.1 Comparison of Feed Grades – Mine Plan and Process Design Criteria**

Element	Units	Average Grade – Mine Plan	Range – Mine Plan	Design Grade
Copper	%	0.376	0.300 to 0.479	0.50
Gold	g/t	0.391	0.309 to 0.480	0.496
Molybdenum	%	0.0183	0.0150 to 0.0249	0.030
Silver	g/t	1.694	1.509 to 1.851	no data
Iron	%	no data	no data	3.00
Sulphur	%	no data	no data	2.1

The head grades of the samples tested by are summarized in Table 16.4.2.

**Table 16.4.2 Sample Feed Assays**

Composite	Assay			Remarks
	Cu (%)	Mo (%)	Au (g/t)	
Hypogene Samples	0.51	0.025	0.51	Average of 53 samples
Supergene Samples	0.41	0.017	0.48	Average of 29 samples
Pebble West Phase I	0.37	n/a	0.34	Average of composite samples
Pebble West Phase II	0.33	n/a	0.30	-
Pebble East	0.80	n/a	0.36	Reported average values

The design head grades for copper and gold are higher than the corresponding mine plan values, as shown in Table 16.3. Practically this may assist with allowing for some excess capacity in the plant. The metallurgical testwork was generally conducted on samples having feed grades approximating the mine plan grades, although some sample grades were lower. This may partially bias the results obtained, although grade versus recovery relationships will accommodate these variations. The molybdenum design feed grade is also higher at 0.030% Mo, and a lower feed grade, particularly for material from the Supergene zones at 0.017% Mo, could affect the recovery and final grade of the molybdenum concentrate product.

#### 16.4.2 ORE CHARACTERISTICS

The physical characteristics of the ore are given in Table 16.4.3.

**Table 16.4.3 Crushing and Grinding Data**

	Pebble West	Pebble East
SG	2.62-2.66	2.63-2.72
Bulk Density (t/m <sup>3</sup> )	1.55-1.73	-
<b>SMC Drop Weight, Axb</b>		
50 percentile	40.2	47.4
75 percentile	30.4	39.3
<b>Bond Crushing Work Index</b>		
50 percentile (kWh/t)	5.9	5.3
75 percentile (kWh/t)	6.9	5.9
<b>Bond Rod Mill Index</b>		
50 percentile (kWh/t)	15.5	13.0
75 percentile (kWh/t)	17.9	14.6
<b>Bond Ball Mill Index</b>		
50 percentile (kWh/t)	14.7	12.9
75 percentile (kWh/t)	16.3	13.5
<b>Abrasion Index</b>		
50 percentile (g)	0.20	0.24
75 percentile (g)	0.28	0.29

Observations regarding the differences in crushing and grinding parameters reported for the two samples tested from the Pebble West and Pebble East deposit include the fact that the SAG mill comminution (SMC) drop weight values, the Bond crushing work index values, the Bond rod mill work index values, and the Bond ball mill work index values reported vary significantly, although the Bond abrasion index values from both the Pebble West and the Pebble East samples are relatively similar.

### 16.4.3 FLOTATION TESTS

The reagents scheme used in the flotation tests was straightforward with sodium ethyl xanthate (SEX) used as the collector, methyl isobutyl carbinol (MIBC) used as the frother, and lime used in the regrind and cleaners to adjust the pH value. Although a number of other collector reagents were tested, the flowsheet depicted in Figure 16.4.1 as the basic flotation system was considered to give acceptable results. The reagents for the molybdenum separation stage require the standard fuel oil collector and MIBC frother reagents, and probably dispersants which require finalization but have been included in the flotation circuit flowsheet.

#### FLOTATION CIRCUIT FLOWSHEET DEVELOPMENT

Various flotation flowsheet configurations and conditions have been tested by a number of laboratories. The flowsheets that were tested have included the following procedural differences after the primary grind:

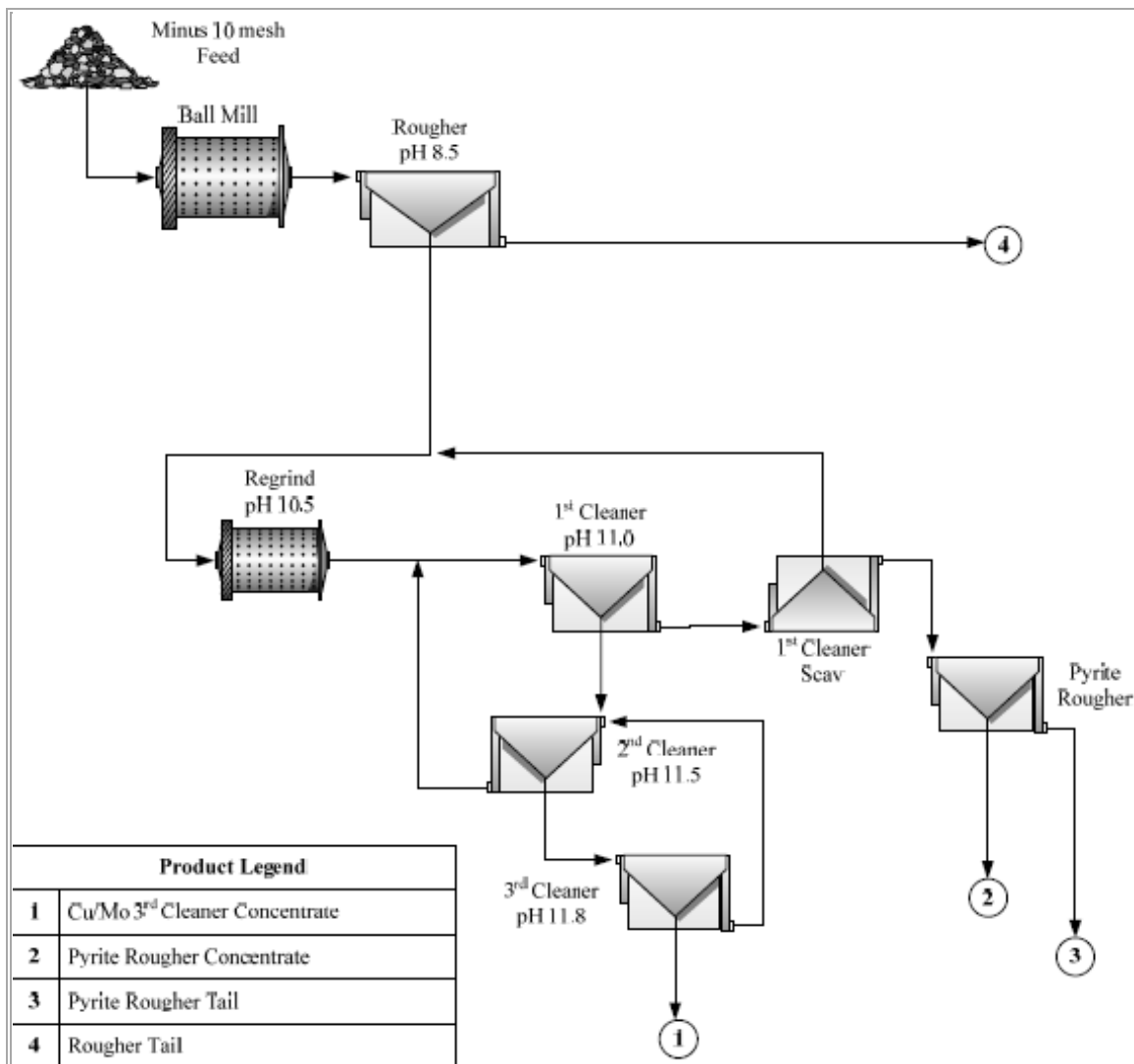
- bulk rougher and cleaner stages, with regrinding of the bulk cleaner concentrate, followed by copper-molybdenum separation (the initial flotation flowsheet);
- a modification of the flowsheet in Figure 16.4.1 that included a desliming step at 10 µm, followed by a scavenger flotation stage, regrinding of the bulk cleaner and scavenger concentrate, in turn followed by the copper-molybdenum separation flotation stage (the bulk flotation flowsheet);
- rougher and scavenger flotation, regrinding of the rougher and scavenger concentrate, followed by a bulk pre-cleaner upgrade stage, in turn followed by the copper-molybdenum separation stage (the pre-cleaner flotation flowsheet);
- as per the flowsheet given in Figure 16.4.1 which incorporates the pre-cleaner upgrade flowsheet but omitting the bulk pre-cleaner upgrade stage (the standard rougher-cleaner flotation flowsheet);
- a multi-stage rougher flotation circuit with a cleaner stage, and a scavenger stage and regrinding the second rougher concentrate with subsequent upgrading of the rougher-cleaner and regrind product into copper-molybdenum separation (the primary bulk rougher-cleaner flotation flowsheet);
- production of a rougher and upgraded scavenger concentrate together with the recycled 1<sup>st</sup> cleaner scavenger concentrate for regrinding, followed by cleaner stages and the separation of the copper and molybdenum, with the gravity treatment of the 1<sup>st</sup> cleaner scavenger tailings (the continued development flotation flowsheet);
- production of a bulk rougher concentrate, regrinding of the bulk rougher concentrate followed by copper-molybdenum rougher and scavenger stages, separation of copper-

molybdenum from the rougher stage concentrate, production of a bulk scavenger concentrate, upgrading the scavenger concentrate with the rougher regrind tailings, and the production of reground scavenger rougher and scavenger products (the split stream flotation flowsheet); and

- a very coarse primary grind followed by flash flotation, with the flash flotation tailings following the split-stream circuit together with the flash flotation tailings, the circuit then following the split-stream flowsheet (the flash plus split-stream flotation flowsheet).

Based on an analysis of these various flowsheet configurations, the standard rougher-cleaner flotation flowsheet, as shown in Figure 16.4.1, was selected as the basis for the design of the flotation circuit. This flowsheet was tested under batch test conditions and subsequently under locked cycle test conditions. The flowsheet and certain test conditions used for this testwork are shown on Figure 16.4.1, but with the modifications that the 3<sup>rd</sup> cleaner concentrate stage has been deleted and a 2<sup>nd</sup> cleaner scavenger stage has been incorporated, as well as the incorporation of a pyrite rougher flotation stage.

**Figure 16.4.1 Standard Bulk Flotation Flowsheet**



The following comments are pertinent with regard to the design of the flotation flowsheet as given in Figure 16.4.1.

- The proposed flotation circuit design is standard and offers no technical risks. Operating conditions such as laboratory tests to commercial plant conditions scale-up factors, retention time, slurry density, and reagent addition rates, are acceptable, and will be confirmed in the next phase of the project.
- A reduced pulp density in the rougher circuit from 35% to 28% solids was found to be beneficial during the testwork. The design assumes 35% solids, and a lower density of 22% was used in the cleaner stages. An evaluation comparing the benefit of the additional recovery with the capital cost of additional flotation cells is recommended.
- A four cleaner stage circuit was required to achieve a 26% Cu concentrate grade for several samples evaluated during the testwork program. The basic conceptual flowsheet design as given in Figure 16.4.1 was for three cleaner stages. On the basis that column cells are successfully used in the industry to upgrade flotation concentrates albeit with poorer stage recoveries, it is advocated that the second stage of cleaning employ column flotation cells, with an attendant scavenger circuit to recover material lost from the column cell. The present flotation circuit design therefore indicates only two stages of cleaning. It is recommended that a trade-off study be conducted to evaluate the potential savings in incorporating a column cell in the design, and having a more conventional three or four stage cleaning circuit.
- Pulp temperatures of between 5°C and 25°C were tested and no discernible effect on the flotation behaviour was observed. Given the location of the Pebble Project, this is an advantage.
- The flotation flowsheet as given in Figure 16.4.1 appears to be robust with respect to the recycling of process water.
- The pyrite to chalcopyrite ratio in the feed, particularly at levels exceeding a ratio of 8 to 1, was found to become detrimental to the final grade of copper concentrate produced, with the attendant higher gold losses in the rejected pyrite. The incorporation of a gold plant into the design of the plant offers the opportunity to increase copper recovery as well as obtaining a return on the recovered gold.
- A copper concentrate grade of 26% Cu has been assumed for the purposes of flowsheet design. A concentrate grade of 24% Cu has been referenced as apparently being marketable, and this aspect requires further evaluation.
- Although primary grind sizes with a  $P_{80}$  of 140  $\mu\text{m}$  were tested, the gain in mineral recovery was apparently not significant and was calculated to be only approximately 5% for copper from a primary grind  $P_{80}$  at 200  $\mu\text{m}$ . However, a different set of results indicate that this difference could be as much as 13% at the final concentrate grade of 26% Cu. This aspect will be discussed in a further section. Confirmatory work needs to be undertaken to characterize the effect of grind on recovery for copper, gold and molybdenum.
- Various reagent suits and pH values were tested. The optimal pH values are given in the design criteria and they were adjusted continuously over the duration of the test. The reagents selected included the collectors SEX, although the Cytec reagents 3302 (xanthate allyl ester),



3418A (dialkyl dithiophosphinate), 3477 (dithiophosphate), and PAX (potassium amyl xanthate) were also tested. The main frother tested was MIBC.

- The reagent carboxymethyl cellulose (CMC) was also tested and incorporated into the flowsheet as a non-sulphide gangue mineral depressant, although addition rates were low at between 5 and 50 g/t.
- The regrind size adopted for the flowsheet was 25 µm. Significantly increased metal losses were observed in going to a regrind size of P<sub>80</sub> below 20 µm.
- The desliming step resulted in a significant amount of metal losses and testing of this flowsheet was discontinued.
- The split-stream flowsheet gave promising results but did not recover secondary copper minerals and the associated molybdenum. This flowsheet option was also not pursued.
- The flash flotation flowsheet gave inferior results and therefore was discontinued.
- The flash plus split stream flowsheet gave similar results to the base case flowsheet and the work was discontinued.
- Locked cycle tests gave better results than the corresponding open cycle test for copper, gold, and molybdenum indicating that recirculating material in the intermediate streams eventually report to the final concentrate product.

#### COPPER, GOLD, AND MOLYBDENUM RECOVERIES INTO A BULK CONCENTRATE

Recovery equations, using multiple linear regression analysis and based on head grades, pyrite content and cyanide-soluble copper as independent variables were given for copper and molybdenum for the supergene and hypogene samples tested. The accuracy and validity of the multiple linear analyses was not verified, but it is considered that the evaluation and dependence of variables as used in the report to obtain the recovery equations was incomplete. It is recommended that variables including physical parameters such as grind size, slurry density, concentrate grade, mass recoveries, and sulphide-sulphur grade, should be incorporated into any future multiple linear analysis conducted.

#### COPPER–MOLYBDENUM SEPARATION TESTWORK

Initial mineralogical evaluations indicated that more than 95% of the molybdenite reported as free grains to the bulk copper-molybdenum concentrate. Based on this information, it was forecast that 99% of the copper and 99.5% of the gold was recovered into the copper-gold concentrate from the copper-molybdenum concentrate, and that 92% of the molybdenum was recovered into the final molybdenum concentrate.

Using the basic copper-molybdenum separation flowsheet design but incorporating six cleaner stages and using sodium hydrogen sulphide (NaHS) with nitrogen gas, test results indicated the values were to be adjusted as follows.

The stage recovery of copper and gold was found to be between 99.4 and 99.8% for copper, and 98.9% for gold for the recovery of copper and gold into a copper concentrate. The recovery was between 92.8 and 98.4% for the molybdenum recovery into the final molybdenum concentrate, with some variations in the numbers depending on the ore lithology tested.

Copper-molybdenum separation using NaHS as the primary reagent and nitrogen as the flotation gas resulted in a 52% Mo concentrate (with 1.37% Cu) and a 22.2% Cu concentrate (with 0.33% Mo). NaHS consumption was high at nearly 300 g/t ore. However, further testwork is recommended to characterize this potentially beneficial copper-molybdenum separation method in greater detail.

## 16.5 GOLD RECOVERY FROM PYRITE CONCENTRATE

Gold recovery into the pyrite flotation concentrate indicated that a wide range of values were observed, namely gold recoveries of between 47 and 97%, with a reported average value of 82%.

Bottle roll tests of the pyrite concentrate at grind sizes of 25 and 10  $\mu\text{m}$  respectively, and leaching for 48 hours, gave the following average dissolution results (Table 16.5.1).

**Table 16.5.1 Bottle Roll Test Results**

Size	Average Dissolution (%)	
	Gold	Silver
P <sub>80</sub> = 25 $\mu\text{m}$	53.2	53.6
P <sub>80</sub> = 10 $\mu\text{m}$	80.2	No Data

The benefits of improved gold (and presumably silver) recovery are apparent with the increase in the fineness of grind from 25 to 10  $\mu\text{m}$ . However, in order to reduce the costs of regrinding the pyrite concentrate generated, a cleaner pyrite flotation stage was added to the flowsheet. Although the mass yield was significantly reduced, an increase in gold loss was observed. More testwork will be required to confirm the results obtained to date.

## 16.6 PRIMARY GRIND SIZE

### 16.6.1 PRIMARY GRIND PARTICLE SIZE AND COPPER RECOVERY

The importance of primary grind size was considered from different perspectives during the testwork investigation. The mineralogical findings have already been discussed, while metallurgical testwork results, as well as an economic evaluation, will now be discussed.

An analysis of metallurgical testwork indicated that the combined flowsheet testwork, normalized to a 26% Cu concentrate grade, gave the results presented in Table 16.7. The sensitivity to grind was confirmed, although the effect was considered not to be significant.

**Table 16.6.1 Effect of Primary Grind on the Recoveries of Copper, Gold, and Molybdenum**

Grind Size (P <sub>80</sub> )	Recovery (%)		
	Copper	Gold	Molybdenum
140 $\mu\text{m}$	76	51	41
200 $\mu\text{m}$	63	10	10
Difference	13	10	10

Another analysis of testwork conducted to investigate the effect of the primary grind size indicated that the average increase in recovery per 10 µm primary grind reduction is 0.42 % for copper, 0.17% for gold and 0.35% for molybdenum in the rougher circuit. The results have been summarized in Table 16.8.

**Table 16.6.2 Average Increase in Recovery per 10 µm Primary Grind Reduction**

Metal	% of Rougher Recovery	% of Cleaner Recovery
Cu	0.42	0.48
Au	0.17	0.15
Mo	0.35	0.34

Based on the general metallurgical criteria established for this project, and arbitrarily regarding a primary grind base case at a primary grind  $P_{80} = 165 \mu\text{m}$ , capital and operating costs were calculated at every 5 µm intervals. This particular financial evaluation established that the optimum grind size is 120 µm. Since the results of this financial grind size evaluation were completed after the base case design had been established, the results were not incorporated into the design.

In summary, it is apparent that the different test programs and interpretations have given generally consistent results indicating that metal recoveries are dependent on the grind size, but that the sensitivity varies according to the type of analysis conducted on the test results.

It is recommended that more testwork results be obtained and analysed for both Pebble West and Pebble East in order to fully characterize the effect of primary grind particle size on the recoveries of copper, gold, and molybdenum.

## 16.7 FLOTATION TIME

The flotation times shown in Table 16.7.1 were used in the design of the flotation circuit.

**Table 16.7.1 Recommended Flotation Retention Time**

Stage	Flotation Time (minutes)		Scale-up Factor Design
	Laboratory	Design	
Bulk Rougher	12	30	2.5
Bulk – 1 <sup>st</sup> Cleaner	4	10	2.5
Bulk – 1 <sup>st</sup> Cleaner Scavenger	5	8	1.5
<b>Bulk Cleaner</b>			
2 <sup>nd</sup> Cleaner	10	60	6 (column)
2 <sup>nd</sup> Cleaner Scavenger	5	50	10

The laboratory flotation retention times in the testwork programs were found to vary significantly, and the values in Table 16.7.1 were selected for the design of the flotation circuit. The retention time design scale-up factors as given in the table are generally those used in the industry, although the 1<sup>st</sup> cleaner

scavenger circuit may benefit from a higher scale-up factor on the basis of minimising losses in the cleaner tailings which could occur as a result of the anticipated higher carrying loads resulting from the regrinding of the rougher concentrate.

### 16.7.1 HIGH PRESSURE GRINDING ROLLS PROCESS OPTION

The potential of using high pressure grinding rolls (HPGR) in the comminution circuit of the Pebble Project was evaluated as an option during the various testwork programs. It was established that a conventional HPGR circuit would probably not be a successful application of this technology as a result of the variable to relatively high content of sericite and clays. The presence of these fine-grained minerals would tend to cushion the crushing action. Any increase in the associated moisture content of this material in the HPGR feed will cause slippage of the roll and a reduction in the throughput as well as an increase in the circulating load of the lumps, or the formation of fines/cakes that could be resistant to screening. However, a potential application of HPGR was identified in what was termed an "ACH" circuit, which incorporates an autogenous mill, a cone crusher, and an HPGR unit and washing screen. The autogenous mill would perform as a scrubber ahead of the screen, as well as break the soft rock components, with the oversize material being returned to the cone crusher and HPGR.

The advantages of an ACH circuit includes a reduction in the consumption of steel grinding media and the bypassing of the softer ore components for onward processing.

## 16.8 METALLURGICAL TESTWORK RECOMMENDATIONS

---

A number of recommendations have been listed in the report in the relevant sections. These include the following:

- Conduct optimization testwork on composites containing varying amounts of pyrite to refine the cleaner circuit pH and regrind size requirements.
- Conduct optimization testwork on composites containing varying amounts of clay to optimize the reagent and flotation pulp density requirements.
- Conduct optimization testwork on high grade molybdenum composites with feed grades in excess of 0.020% Mo to confirm the indicated recovery and grade data.
- Additional locked cycle test work should be completed on samples from the illite-pyrite domain.
- On the assumption that a secondary gold-recovery plant is incorporated into the flowsheet, the following testwork will be required:
  - Conduct testwork at a higher slurry pH value in the 1<sup>st</sup> cleaner circuit to investigate the effect on the bulk concentrate grade.
  - Perform leach testwork to establish process design criteria.
  - Conduct detoxification testwork to establish the design criteria for the detoxification of the gold leach tailings.
  - Conduct optimization test focusing on mass recoveries in order to reduce the capital costs and the operating costs for the secondary gold plant.

- Conduct laboratory scale testwork to establish the potential benefits of using an Isa mill in the regrind circuit.
- The potential benefits of a High Pressure Grinding Roll (HPGR) circuit should be investigated. If significantly beneficial, the practicality of operating the plant under these conditions has to be established.
- Conduct a rigorous multiple linear regression analysis on all the relevant metallurgical test data incorporating all the variables which have been considered to possibly influence the recovery and grade of the final concentrates.

## 16.9 PROCESS PLANT DESIGN

---

The proposed Pebble concentrator has been designed to process a nominal 200,000 tons per day of copper-gold-molybdenum porphyry ore. The concentrator will produce a marketable copper concentrate of 26% Cu containing about 18 g/t Au, as well as a saleable molybdenum by-product, and doré.

### 16.9.1 SUMMARY

The unit processes selected were based on conventional industry standard methods of copper-gold recovery, supported by the results of metallurgical testing performed at various laboratories and which were described earlier in this report. The metallurgical processing procedures have been designed to produce a saleable high grade copper-gold concentrate. The recovery of molybdenum as a by-product has also been included in the overall project and the recovery process has been incorporated in the process design. The copper concentrate will be transferred from the processing facility at the Mine Site by pipeline to a remote filter plant facility at the Port Site prior to the shipping of the concentrate to the smelters.

The overall treatment plant will consist of a crushing stage and comminution, followed by the flotation process to recover the copper and molybdenum together with the gold. This will be followed by a molybdenum-copper separation flotation process. A separate gold plant has also been incorporated for the recovery of gold from the cleaner stage flotation tailings. As shown in Figure 16.13.1 to Figure 16.13.9, the flotation concentrate will be separated into a molybdenum by-product, and a saleable grade copper concentrate which will be thickened and pumped to the filter plant at the Port Site. The copper concentrate will be filtered at the Port Site and sent to the concentrate stockpile for storage prior to the subsequent reclaim and shipping to smelters.

The final flotation tailings will be thickened and will be disposed of using a conventional TSF. Process water will be recovered and recycled from the tailings thickener and the tailings storage facility. Fresh water will only be used for gland service and reagent preparation, and for the mill lubrication cooling system.

The process plant will consist of the following unit operations and facilities:

- run-of-mine (ROM) ore receiving;
- overland conveying system;

- primary crushing;
- crushed ore stockpile;
- ore reclaim;
- a semi-autogenous grinding (SAG) and ball mill grinding circuit incorporating cyclones for classification;
- SAG mill pebble crushing circuit;
- copper-molybdenum rougher and scavenger flotation;
- copper-molybdenum cleaner flotation;
- copper-molybdenum separation by flotation;
- molybdenum thickening and filtration;
- molybdenum product processing;
- copper concentrate thickening;
- copper concentrate transfer by pumping to the filter plant;
- copper concentrate filtration, and dispatch;
- gold recovery by co-recovery with the copper concentrate and a gold leaching and smelting plant;
- tailings thickening and process water recovery; and
- tailings disposal to a TSF.

Simplified process flowsheets, excluding the utilities and water system and details, are given as Figure 16.13.1 to Figure 16.13.9. Where multiple processing lines or units exist, only one such typical processing line or unit is shown on the flowsheets.

### **16.9.2 MAJOR PROCESS DESIGN CRITERIA**

The concentrator has been designed to process a nominal 200,000 tons per day, equivalent to 73,000,000 tons per year. The major process criteria used in the design are outlined in Table 16.9.1.

The design parameters are based on testwork results obtained by various test laboratories, reviewed by Wardrop, and used in the overall design of the process plant. The plant design will be reviewed in the subsequent relevant sections.

The grinding mills were sized based on various simulations conducted by various grinding consultants. Wardrop evaluated the results of the grinding mill simulation results, as well as using the Bond work index data for SAG and ball mills, together with feed and product sizes as determined from the testwork results. The regrind mills were sized using the conventional Bond work index equation for tower mills, together with recommendations from the supplier, and using the standard tower mill to ball mill efficiency factor.

**Table 16.9.1 Major Process Design Criteria**

Criteria	Unit	
Operating Year	day	365
Treatment Rate	st/day	200,000
Crushing Availability	%	65
Grinding and Flotation Availability	%	94
Primary Crushing Rate	st/h	12,821
Moisture Content	%	5
Milling and Flotation Process Rate	st/h	8,865
SAG Mill Feed Size, 80% Passing	µm	150,000
SAG Mill Transfer Size, 80% Passing	µm	2,000 to 6,000
Ball Mill Grind Size, 80% Passing	µm	200
Ball Mill Circulating Load	%	300
Bond Ball Mill Work Index	kWh/t	16.2
Bond Abrasion Index	g	0.27
Concentrate Regrind Size, 80% Passing	µm	25

The flotation cells were sized based on the optimum flotation times as determined during the laboratory testwork. Typical scale-up factors have been applied.

### 16.9.3 PLANT DESIGN

#### OPERATING SCHEDULE AND AVAILABILITY

The primary crushing and process plant will be designed to operate on the schedule basis of two 12-hour shifts per day, for 365 days per year.

The primary crusher overall availability will be 65% and the grinding and flotation circuit availability will have a running time of 94%. This will allow sufficient downtime for the scheduled and unscheduled maintenance of the crushing and process plant equipment.

### 16.9.4 PROCESS PLANT DESCRIPTION

In the process plant description that follows, only the major items of equipment will be described and referenced. The throughput and treatment rates have been summarized in the mass balance summary, which is included at the end of this section (see Table 16.13.1) and which was primarily established to confirm retention times, and flotation circuit parameters.

#### PRIMARY CRUSHING AND CRUSHED ORE STOCKPILE AND RECLAIM

A conventional gyratory crusher facility will be designed to crush run-of-mine (ROM) ore from both Pebble East and Pebble West in preparation for the subsequent grinding process at an average rate of 12,821 tons per hour. The major equipment and facilities in this area includes:

- dump pockets;

- hydraulic rock breakers;
- gyratory crushers;
- surge bins;
- crushed ore stockpile (127,890 tons live capacity);
- reclaim belt feeders;
- conveyor belts, metal detectors, self-cleaning magnets, and belt tear detectors;
- belt scales; and
- dust collection system.

The ROM ore will be trucked from the open pit to the primary crusher by haul trucks. The ore will be reduced to 80% minus 6 inches using a gyratory crusher. A rock breaker will be installed to break any oversize rocks.

The crusher product will be discharged onto a conveyor system and ultimately be deposited on the coarse ore stockpile via a crushed ore surge bin.

The crushed ore stockpile will have a live capacity of 127,890 tons. The ore will be reclaimed from this stockpile by belt feeders at a nominal rate of 8,865 tons per hour. The belt feeders will feed a conveyor, which in turn will feed one of two SAG mill lines. The conveyor belt system feeding the coarse ore stockpile will be equipped with the appropriate belt scale, belt magnets, and belt tear detectors.

The crushed ore facility and the crushed ore stockpile will be equipped with dust collection systems to control fugitive dust that will be generated during conveyor loading and the transportation of the ore.

#### GRINDING AND CLASSIFICATION

The grinding circuit will consist of two lines each containing a SAG mill with a two-ball mill combination circuit. It will be a two-stage operation with the SAG mill in closed circuit with pebble crushers, and the two ball mills in closed circuit with the classifying cyclones. The SAG mill will be equipped with pebble ports to remove pebbles, which will be screened and the oversize crushed in the pebble crusher circuit. The grinding will be conducted as a wet process at a nominal rate of 8,865 tons per hour of material. The grinding circuit will include:

- conveyor feed belts;
- conveyor belt weigh scale;
- two lines each containing a SAG mill with a two-ball mill combination circuit including pebble crushers;
- SAG mill – 12.1 m diameter x 7.62 m long (40 ft x 25 ft);
- ball mill – 7.62 m diameter x 12.5 m long (26 ft x 40 ft);
- four pebble crushers;
- vibrating screens;



- SAG mill/ball mill discharge pumpbox;
- cyclone feed slurry pumps;
- cyclone clusters;
- mass flow meters;
- particle size analyzers; and
- sampler system.

The ore from the coarse ore stockpile will be reclaimed under controlled feed rate conditions using belt feeders. These feeders will discharge the material onto a conveyor belt feeding the SAG mill. A belt scale will control the feed to the SAG mill. Water will be added to the SAG mill feed material to assist the grinding process. The SAG mill will operate at a critical speed of 78%.

The SAG mill discharge end will be equipped with pebble ports to remove the critical size material. The SAG mill discharge will be screened by the mill trommel and a vibrating screen. The oversize material will be conveyed via transfer conveyors to the pebble crushers. The pebble crushers will crush the pebbles to a  $P_{80}$  of 12.0 mm. The crushed material will be returned to the conveyor belt feeding the SAG mill for further grinding. The trommel underflow will be discharged into the SAG mill discharge pumpbox.

The SAG mill discharge pumpbox will serve as a distribution box to equally split the slurry into two portions. The split slurries will be separately to two cyclone classification clusters.

The product from each ball mill will be discharged into the cyclone feed pumpbox combining with the SAG mill discharge to become the cyclone feed. The classification cut size for the cyclones will be a  $P_{80}$  of 200  $\mu\text{m}$ , and the circulating load to the individual ball mill circuits will be 300% with the cyclone underflow returning to the ball mill as feed material.

The new feed to each grinding mill circuit will be 4,433 tons per hour and the combined total of the two grinding lines (8,865 tons per hour) will constitute the feed rate to the copper flotation circuit. The ball mills will operate at a critical speed of 78%. Dilution water will be added to the grinding circuit as required.

The cyclone overflow from both classification circuits will be discharged into the copper flotation conditioning tanks ahead of the flotation process. The pulp density of the cyclone overflow slurry will be approximately 35% solids.

Provision will be made for the addition of lime to the SAG mill for the adjustment of the pH of the slurry in the grinding circuit prior to the flotation process. Flotation reagents will also be added as required by the operation.

Grinding media will be added to all the mills in order to maintain the grinding efficiency. Steel balls will be periodically added to each mill using a ball charging kibble.

## FLOTATION CIRCUIT

The milled ore will be subjected to flotation to recover the targeted molybdenum, copper and gold minerals into a high-grade copper concentrate containing gold, and a high-grade molybdenum concentrate.

### *Bulk Copper-Molybdenum Flotation Circuit*

The two lines of bulk copper-molybdenum flotation circuits will each include the following equipment:

- conditioning tank;
- flotation reagent addition facilities;
- three lines each of bulk rougher flotation tank cells (six 500 m<sup>3</sup> cells each);
- two regrind tower mills;
- two classification cyclone clusters;
- 1<sup>st</sup> cleaner flotation tank cells;
- 1<sup>st</sup> cleaner scavenger flotation tank cells;
- 2<sup>nd</sup> cleaner column flotation cells;
- 2<sup>nd</sup> cleaner scavenger flotation cells;
- pumpboxes and standpipes;
- concentrate thickeners;
- slurry and concentrate pumps;
- particle-size analyzers for each regrind stage; and
- sampling system.

The cyclone overflow from each grinding circuit line will be the feed to the flotation circuit conditioning tank. The cyclone overflow slurry will be conditioned in each of the two bulk flotation conditioning tanks. Flotation reagents will be added to the conditioning tank as defined through testing. The flotation reagents added will be the collector, SEX, and the frother, MIBC, with dispersants added as required. Lime will be used as a pH modifier throughout the process. Provision will be made for the staged addition of the reagents in the flotation circuit.

The conditioned slurry will overflow the conditioning tank into the bulk rougher flotation tank cells. Rougher concentrate will be collected and will be discharged into the regrind distributor from where it will be discharged to the regrind circuit cyclone feed pumpbox, and then pumped to the regrind classification cyclone. The 1<sup>st</sup> cleaner scavenger concentrate will also be collected in the regrind distributor to join the rougher concentrate prior to regrinding. The regrind circuit will assist to completely liberate the fine-sized grains of the copper and molybdenum minerals from the gangue constituents and to enhance upgrading of the copper and molybdenum concentrates in the subsequent cleaning stages.

The regrind circuit will also feature a centrifugal gravity concentrator circuit for gold recovery. A portion of the regrind cyclone underflow will be passed through the centrifugal concentrators in order to recover particulate gold grains which may otherwise be lost in the flotation circuit. The rougher gravity concentrate collected in the first gravity concentrator will be subjected to a further stage of concentration to upgrade the gold product. The gold concentrate recovered will be pumped to the copper concentrate thickener for dewatering and filtering.

The rougher tailings will be sampled automatically in each line prior to discharge into the final rougher tailings pumpbox. This stream will constitute one of the two final tailings leaving the plant.

The rougher regrind circuit cyclone will separate the finely ground flotation concentrate into a cyclone overflow product according to the design particle size  $P_{80}$  of 25  $\mu\text{m}$ . The coarser regrind cyclone underflow will be the feed for the rougher regrind mill. The tailings from the centrifugal gravity concentrators will also be combined with the rest of the feed material to the regrind mill. The regrind mills will be vertical tower mills. The regrind mills will discharge into the cyclone feed pumpbox together with the rougher and 1<sup>st</sup> cleaner scavenger flotation concentrates. All this material will constitute the feed for classification by the regrind cyclone.

The cyclone overflow from the regrind circuit will combine with the 2<sup>nd</sup> cleaner scavenger tailings as the feed to the 1<sup>st</sup> cleaner stage. The 1<sup>st</sup> cleaner concentrate will report to the 2<sup>nd</sup> cleaner column cell circuit. The 1<sup>st</sup> cleaner circuit and the 1<sup>st</sup> cleaner scavenger circuit will have concentrate launder interchangeability for flexibility of operational conditions. The last cells of the 1<sup>st</sup> cleaner circuit could be used for 1<sup>st</sup> cleaner scavenger concentrate collection, while the first cell in the 1<sup>st</sup> cleaner scavenger circuit could be used as a 1<sup>st</sup> cleaner cell.

The concentrate from the 1<sup>st</sup> cleaner stage will feed the 2<sup>nd</sup> cleaner flotation stage with the 2<sup>nd</sup> cleaner concentrate reporting to the bulk concentrate thickener. The concentrate from the 2<sup>nd</sup> cleaner scavenger stage will be returned to the 1<sup>st</sup> cleaner stage.

The tailings from the 1<sup>st</sup> cleaner scavenger circuit will form the feed to the pyritic tailings pumpbox from where the material can be discarded to a separate high-pyrite content collection area within the TSF, or constitute the feed to the gold recovery circuit.

The final copper-molybdenum concentrate will feed the bulk concentrate thickener.

Conventional tank flotation cells will be used for the bulk flotation circuit, with column cells used for the 2<sup>nd</sup> cleaner stage.

Provision will be made for the bulk concentrate thickener overflow water to be re-used in the bulk flotation circuit and the grinding circuit as dilution water providing this does not have a deleterious effect on the flotation of the copper, molybdenum and gold minerals.

#### COPPER-MOLYBDENUM SEPARATION

The copper-molybdenum separation circuit has not been included in the simplified flowsheets, but consists of the following unit operations.

- conditioning tank;

- rougher and scavenger flotation cells;
- cleaner flotation stages;
- reagent preparation and addition facilities;
- samplers;
- molybdenum product thickeners; and
- molybdenum product drying, filtration, and packaging system.

The molybdenum product will be dried, packaged, and despatched from the mine site. The copper concentrate will be collected in the copper concentrate thickener and transferred by pipeline to the port site filtration plant.

#### COPPER CONCENTRATE HANDLING

The copper flotation concentrate, together with the gravity gold concentrate, will be thickened and stored prior to pumping by concentrate pipeline to the port site. At the port site, the concentrate will be collected, dewatered, filtered, and loaded onto ships for shipping to smelters. The copper concentrate handling circuit will have the following equipment:

- mine site copper concentrate thickener;
- mine site copper concentrate thickener overflow standpipe;
- mine site copper concentrate storage tanks;
- mine site copper concentrate pipeline slurry pumps;
- copper concentrate pipeline;
- port site process water tank and pump;
- port site process water return pumps;
- port site copper concentrate thickener;
- port site copper concentrate stock tank;
- port site copper concentrate filter press; and
- port site copper concentrate storage and dispatch facility.

The copper concentrate produced will be pumped from the copper-molybdenum separation stage to the copper concentrate thickener. Flocculant will be added to the thickener feed to aid the settling process. The thickened concentrate will be pumped to the concentrate stock tank using thickener underflow slurry pumps. The underflow density will be about 60% solids. The concentrate stock tank will be an agitated tank that will serve as the feed tank for the concentrate pipeline from which the copper concentrate will be pumped to the port site filter plant. The copper concentrate will be pumped to the port site thickener and thickened to about 60% solids prior to filtering. The thickener underflow will feed the filter plant stock tank.

The concentrate thickener overflow will be pumped to the process water tank, which in turn will feed the return water pumps for transporting the water back to the mine site using a second pipeline. This return water will be recycled with the mine site process water for reuse. The 85-mile long pipeline will also periodically be flushed with process water. This flushing water will be combined with the port site process water and returned to the mine site.

The copper concentrate filter will be a filter press unit. Since filtration with a filter press unit will be a batch process, the copper concentrate stock tank will also act as a surge tank for the filtration operation. The filter press will dewater the concentrate to produce a final concentrate with a moisture content of about 8%. The filter press solids will be discharged to the concentrate stockpile in a designated storage facility. The concentrate will periodically be loaded onto ships for dispatch to smelters.

#### TAILINGS HANDLING

The flotation tailings from the flotation circuit will be the final plant tailings.

The process plant tailings will consist of two streams, namely the rougher flotation tailings, and the 1<sup>st</sup> cleaner scavenger tailings. Each stream will require a different handling procedure. The rougher tailings will be pumped to the tailings thickener prior to pumping the thickened tailings to the tailings pond for final deposition. The 1<sup>st</sup> cleaner scavenger tailings will be collected in a designated area of the tailings storage facility. The tailings handling circuit will have the following equipment:

- collection box;
- tailings thickener;
- tailings thickener overflow process
- water collection system;
- pumpbox;
- flocculant addition facility;
- slurry pumps; and
- reclaim water barge and pumps.

Thickener overflow solution from the tailings thickener will be pumped to the process water system pond or process water tank for recycling. Process water delivered from the port site will also be collected in the process water collection pond system.

#### REAGENT HANDLING AND STORAGE

Various chemical reagents will be added to the process slurry stream to facilitate the copper-molybdenum flotation process. The preparation of the various reagents will require:

- a bulk reagent handling system;
- mix and holding tanks;

- metering pumps;
- a flocculant preparation facility;
- a lime slaking and distribution facility;
- eye-wash and safety showers; and
- applicable safety equipment.

Various chemical reagents will be added to the grinding and flotation circuit to modify the mineral particle surfaces and enhance the floatability of the valuable mineral particles into the copper-gold concentrate product. Fresh water will be used in the making up or the dilution of the various reagents that will be supplied in powder/solids form, or which require dilution prior to the addition to the slurry. These prepared solutions will be added to the addition points of the various flotation circuits and streams using metering pumps. The SEX collector reagent will be made up to a solution of 30% strength in a mixing tank, and then transferred to the holding tank, from where the solution will be pumped to the addition point. The frother reagent, MIBC, will not be diluted and will be pumped directly from the bulk containers to the point of addition using metering pumps.

Flocculant will be prepared in the standard manner as a dilute solution of 0.5% solution strength. This will be further diluted in the thickener feed well.

Lime, as quick-lime, will be delivered in bulk and will be off-loaded pneumatically into a silo. The lime will then be prepared in a lime slaking system as 15% concentration slurry. This lime slurry will be pumped to the points of addition using a closed loop system. The valves will be controlled by pH monitors that will control the amount of lime added.

The reagents required for the molybdenum concentrate processing circuit include fuel oil, added as a 100% strength reagent, the dispersants which will be made up to 1% solution strength, and sodium hydroxide and sodium hydrosulphide.

To ensure spill containment, the reagent preparation and storage facility will be located within a containment area designed to accommodate 110% of the content of the largest tank. In addition, each reagent will be prepared in its own bunded area in order to limit spillage and facilitate its return to its respective mixing tank. The storage tanks will be equipped with level indicators and instrumentation to ensure that spills do not occur during normal operation. Appropriate ventilation, fire and safety protection, and Material Safety Data Sheet (MSDS) stations will be provided at the facility.

Each reagent line and addition point will be labelled in accordance with Workplace Hazardous Materials Information Systems (WHMIS) standards. All operational personnel will receive WHMIS training, along with additional training for the safe handling and use of the reagents.

#### ASSAY AND METALLURGICAL LABORATORY

The assay laboratory will be equipped with the necessary analytical instruments to provide all routine assays for the mine, the concentrator, and the environment departments. The most important of these instruments includes:

- fire assay equipment;
- atomic absorption spectrophotometer (AAS);
- x-ray fluorescence spectrometer (XRF); and
- Leco furnace.

The metallurgical laboratory will undertake all necessary testwork to monitor metallurgical performance and, more importantly, to improve process flowsheet unit operations and efficiencies. The laboratory will be equipped with laboratory crushers, ball and stirred mills, particle size analysis sieves, flotation cells, filtering devices, balances, and pH meters.

#### WATER SUPPLY

Two separate water supply systems for fresh water and process water will be provided to support the operation.

##### *Fresh Water Supply System*

Fresh and potable water will be supplied to a fresh/fire water storage tank from the open pit dewatering systems, and from wells. Fresh water will be used primarily for the following:

- fire water for emergency use;
- cooling water for mill motors and mill lubrication systems;
- gland service for the slurry pumps;
- reagent make-up; and
- potable water supply.

The fresh/fire water tank will be equipped with a standpipe, which will ensure that the tank is always holding at least 40 m<sup>3</sup> of water, equivalent to a 2-hour supply of fire water.

The potable water from the fresh water source will be treated and stored in the potable water storage tank prior to delivery to various service points.

##### *Process Water Supply System*

Some process water generated in the flotation circuit as concentrate thickener overflow solution will be re-used in the respective flotation circuit. Tailings thickener overflow water will be used in the grinding circuit. Excess water will be delivered to the process water tank for recirculation. Reclaimed water will be pumped from the tailings pond to the process water pond and tank for distribution to the points of usage.

#### AIR SUPPLY

Separate air service systems will supply air to the following areas:

- Low-pressure air for flotation cells will be provided by air blowers.

- High-pressure air for the filter press and drying of concentrate will be provided by dedicated air compressors.
- Instrument air will come from the plant air compressors and will be dried and stored in a dedicated air receiver.

#### ON-LINE SAMPLE ANALYSIS

The plant will rely on the on-stream analyzer for process control. An on-line analyzer will analyze each flotation stage for each respective stage in the flotation circuit. A sufficient number of samples will be taken so that the circuit can be balanced by analytical resultant and calculation as required. Specific samples that will also be taken for metallurgical accounting purposes will be the flotation feed to the circuit, the final tailings, and the final copper and molybdenum concentrate samples; and these samples will be assayed in the assay laboratory. An on-stream particle size monitor will determine the P<sub>80</sub> particle size of the primary cyclone overflow and the regrind circuit products.

### 16.10 PROCESS PLANT DESIGN DISCUSSION

---

The following due diligence was undertaken on specific aspects of the process design. This review of the process design and the equipment selected is based on a throughput of 200,000 tons per day.

#### 16.10.1 PLANT AVAILABILITY

The crushing plant circuit availability at 65% is considered to be conservative, and could be increased if operational conditions require an increase in the crushing circuit availability.

The overall plant availability of 94% is consistent with current plant design practice assuming that an acceptable preventive maintenance program is in place. This level of availability is also in keeping with large-tonnage operations in South America.

#### 16.10.2 SURGE CAPACITY

The surge capacity of the coarse ore stockpile is equivalent to a live capacity of 127,890 tons, or about 15 hours of equivalent throughput. A commonly used design duration is for a live capacity equivalent to the throughput for 1 day. However, the material in the non-live part of the stockpile could readily be accessed for processing using dozers, and with the total stockpile capacity at 394,680 tons, this is equivalent to 47 hours of throughput.

#### 16.10.3 GRINDING CIRCUIT DESIGN

Table 16.10.1 presents selected details from the grinding circuit design advocated for the Pebble Project.

The Pebble Project elected to use among the largest suitable mills and related crushers in order to achieve the required treatment rate of 200,000 tons per day.



**Table 16.10.1 Grinding Circuit Design Parameters**

Grinding Parameter	Value
Running Time	94%
Feed Size	127 to 150 mm
Grinding Lines	2 lines; SAG mill/pebble crusher/ball mill
Configuration of Each Grinding Line	1 SAG mill with 4 shared pebble crushers and 2 ball mills
<b>SAG Mill Parameters</b>	
Mill Size	40 ft diameter x 25 ft length
Mill Power	29 MW gearless drive motor
Steel Charge	16 to 22%
Critical Speed	78%
Pebble Circulating Load	15% of fresh feed
Pumpbox Residence Time	0.5 minutes
<b>Ball Mill Parameters</b>	
Mill Size	26 ft diameter x 40 ft length
Mill Power	16.4 MW gearless drive motor
Mill Steel Charge	30 to 40%
Mill Critical Speed	78%
Circulating Load	300%
Transfer Size	4,000 to 6,000 µm
Classification	cyclone cluster

Simulations using power-based proprietary software models and the Bond grinding work index information resulted in a grinding circuit configuration being proposed, which consisted of an open-circuit SABC configuration. Table 16.10.2 presents the relevant average values and design criteria for the proposed grinding circuit.

**Table 16.10.2 Grinding Circuit Simulation Criteria**

Parameter/Design Feature	Value
Bond Rod Mill Work Index (kWh/t)	15.6
Bond Ball Mill Work Index (kWh/t)	14.2
Bond Crushability Work Index (kWh/t)	5.8
Abrasion Index Work Index (g)	0.217
Feed Size, F <sub>80</sub> (mm)	150
Product Size, P <sub>80</sub> (µm)	200
Number of Ball Mills per SAG Mill	2
Number of SAG Mills	2
SAG Mill Dimensions	44 ft diameter x 22 ft long
Ball Mill Dimensions	30 ft diameter x 45 ft long

Three grinding consultants were used in order to predict grinding plant performance and these were the following:

- the Julius Kruttschnitt Mineral Research Centre (JKMRC) simulation method (JKSim Met)
- the comminution economic evaluation tool (CEET) simulation method
- the MinePower 2000 modelling used by DJB Consultants Inc.

A brief comparison of the three methodologies using the same basic grinding circuit-circuit for the pebble crushing gave the following average throughput results for two SAG mill/2 ball mill/pebble crusher grinding lines, as given in Table 16.10.3, indicating that the anticipated treatment rate exceeds the required throughput rate of 200,000 tons per day.

**Table 16.10.3 Simulation Throughput Comparison Data**

Method	Throughput	
	tons/day	tonnes/day
DJB	221,103	200,540
JKSim Met	235,181	213,309
CEET	214,546	194,593

Ultimately, the two grinding circuits investigated in greater detail consisted of the SABC-A circuit and SABC-B circuit, described as two grinding circuit lines each consisting of 94% availability, with the former circuit having crushed pebbles from the SAG mill being returned to the SAG mill, and the SABC-B circuit having the crushed pebbles returned to the ball mills. Table 16.10.4 presents some of the characteristics of both circuits. Although the SABC-B circuit did indicate an increase in the throughput compared with the SABC-A circuit, the SABC-A circuit was adopted for the design of the grinding circuit.

The parameters used in the grinding circuit design conform to the data given in the tables above; they also conform to the grindability index value of 14.2 kWh/t, which is the average of the Pebble West and Pebble East 50 percentile value, as reported in Table 16.4.3.

The SABC-A circuit was found to be SAG mill limited, although the ball mills met or exceeded the fineness of grind target value of  $P_{80} = 200 \mu\text{m}$ . The SABC-B circuit was still SAG mill limited but less so than the SABC-A circuit.

The JKSim Met model predicted that the SAG mill will draw 25.3 MW at the mill shell and the ball mill will draw 15.4 MW.

During the various years of production, the hardness of the ore will vary. This will affect the throughputs of the various mills, and the final grind  $P_{80}$  value. The production years with the hardest ores may result in throughputs below the target value of 200,000 tons per day.

**Table 16.10.4 Summary of SABC-A and SABC-B Grinding Circuits**

	SABC-A Circuit	SABC-B Circuit
Circuit Availability	94%	94%
SG	2.7	2.7
One SAG Mill: 40 ft x 25 ft	18% ball charge	18% ball charge
	F <sub>80</sub> = 150 mm	F <sub>80</sub> = 150 mm
	78% critical speed	78% critical speed
	29 MW	29 MW
	T <sub>80</sub> = 2,000 to 6,000 µm	T <sub>80</sub> = 2,000 to 6,000 µm
Two Ball Mills: 26 ft x 40 ft	33% ball charge	33% ball charge
	78% critical speed	78% critical speed
	26.4 MW each	26.4 MW each
	P <sub>80</sub> = 200 µm	P <sub>80</sub> = 200 µm
Four MP1000 Pebble Crushers	750 kW	750 kW
Pebble Circuit	crushed pebbles are returned to the SAG mill	crushed pebbles are returned to the ball mill

Minor increases in throughput were demonstrated as possibly attainable by reducing the feed size of the SAG mill by pre-screening the feed, but this would be an expensive modification for relatively minor throughput increases.

Simulation work has demonstrated that a treatment rate of 100,000 tons per day per grinding line consisting of one SAG and two ball mills with a pebble crusher is feasible. In addition, further evaluations confirmed that having two grinding lines as shown on the flowsheets with the SAG mill dimensions at 40 ft x 25 ft and with a 29.0 MW motor, and two ball mills, each with 26 ft x 40 ft and with a 16.4 MW motor, would be feasible. Using the grinding data as determined by testwork, which is given in the tables above, it was demonstrated that a throughput of 200,000 tons per day was feasible. Also, discussions were initiated with mill manufacturers. The salient points of these discussions were the following:

- FL Smidth indicated that high steel ball loads of 18 to 20% in SAG mills was routine practice, and that a critical speed operation of 78% was typical operating practice. FL Smidth also indicated that the ball mill sizes could be slightly larger at 27 ft x 45 ft compared with the proposed 26 ft x 40 ft, and that the power requirement for the motor would be higher at 19.0 MW compared with the proposed 16.4 MW.
- Discussions with Metso indicated that the expected power draw for the Pebble Project SAG mill would probably be higher at 26.4 MW under the operating conditions given. The ball mill sizes were considered to be too small, and a 26 ft x 44 ft ball mill was suggested with 16.4 MW motors. The other comment made by Metso was that the pebble circulation load should be higher at up to 40%, whereas the design used a pebble circulating load of 25%.
- Metso also indicated that a one SAG/two ball mill/pebble crusher grinding line can achieve 100,000 tons per day but that it would be dependent on the ore properties. A grinding circuit design was presently underway for a 42 ft x 25 ft SAG mill with two 26 ft x 40 ft ball mills, which would grind in excess of 100,000 tons per day at an availability of 92%.

Similar mill sizes and grinding circuits are being commissioned in order to utilize economies of scale, and that this target grind treatment rate is feasible providing that the ore properties have been properly defined.

Despite these challenges, the proposed Pebble Project SABC-A grinding circuit design can be managed in a manner that minimizes the technical risks.

#### 16.10.4 GRINDING MEDIA CONSUMPTION

The grinding media storage capacity of 21 days is dictated by shipping delivery intervals. This storage capacity has provisionally been recommended for the three types of steel grinding media which will be used, namely:

- SAG mill, 5 inch diameter, 73 tons per day;
- Ball mill, 3 inch diameter, 86 tons per day; and
- Tower mill, 1 inch diameter, 22 tons per day.

This storage capacity has been allowed for in the layout of the grinding circuit.

#### 16.10.5 MILL LINER CONSUMPTION

Although a mill liner consumption value has been given for all the mill types, it is recommended that a minimum of two full sets of liners be available at any given time for the SAG mill, three full sets of liners for the ball mills, and three full set of liners for the regrind tower mills.

#### 16.10.6 FLOTATION

Selected flotation circuit design parameters are given in Table 16.10.5.

The overall design of the flotation circuit is conventional and the unit processes incorporated, and the equipment proposed is based on typical industry standards. The following comments regarding the design of the flotation circuit are relevant.

**Table 16.10.5 Selected Flotation Design Parameters**

Parameter	Value
<b>Rougher Circuit</b>	
Flotation Feed Particle Size	$P_{80} = 200 \mu\text{m}$
Flotation Concentrate Particle Size	$P_{80} = 185 \mu\text{m}$
Slurry Density	35%
Rougher Mass Recovery	12%
Residence Time	30 min
Volume of Flotation Cell	500 m <sup>3</sup>
Flotation Cell Effective Volume	90%
Cell Configuration	3 rows of 6 cells each
Maximum Carry Rate	2 t/h per m <sup>2</sup>

*Table continues...*

...Table 16.10.5 (cont'd)

Parameter	Value
<b>Regrind Circuit</b>	
Regrind Particle Size	$P_{80} = 185 \mu\text{m}$
Regrind Product Particle Size	$P_{80} = 25 \mu\text{m}$
Bond Work Index – Average	13.5 kWh/tonne
Number of Regrind Mills	4
Regrind Mill Type	VTM-3000, 2.2 MW
<b>1<sup>st</sup> Cleaner Circuit</b>	
Slurry Density	22%
Residence Time Scale-Up Factor	2.5
Volume of Flotation Cells	100 m <sup>3</sup>
Flotation Cell Effective Volume	90%
Maximum Carry Rate	2 t/h per m <sup>2</sup>
Cells Configuration	2 rows of 3 cells each
<b>1st Cleaner Scavenger Circuit</b>	
Slurry Density	22%
Residence Time Scale-Up Factor	1.5
Volume of Flotation Cells	100 m <sup>3</sup>
Flotation Cell Effective Volume	90%
Maximum Carry Rate	2 t/h per m <sup>2</sup>
Cell Configuration	2 rows of 2 cells each

The rougher concentrate particle size  $P_{80}$  is 185  $\mu\text{m}$ , based on the testwork. This value was not conclusively shown in the testwork results with only two of the three samples tested indicating that the concentrate is finer than the primary grinding size  $P_{80}$  of 200  $\mu\text{m}$ . Until this data is confirmed, the concentrate particle size should be maintained as  $P_{80}$  of 200  $\mu\text{m}$  for the purposes of the regrind circuit design (final regrind concentrate is  $P_{80}$  of 25  $\mu\text{m}$ ).

- The flotation feed slurry density was taken to be 35% solids. Improved flotation recoveries were obtained at lower slurry densities, and this affect requires characterization.
- The rougher concentrate mass recovery is taken to be 12%, although 14% has also been given in the testwork.
- The residence time has been designed to be 30 minutes, but this requires confirmation based on the final selection of the flotation cell configuration and cell size.
- The number of flotation cells has been calculated on the basis of 90% effective volume, as given in the design parameters and this is the industry accepted value. For purposes of this design, the rougher flotation circuit will consist of three rows each containing six 500 m<sup>3</sup> flotation cells.
- The maximum carry rate has been calculated as being about 0.5 t/h/m<sup>2</sup> and this is an acceptable value.
- The residence time per flotation cell is 1.4 minutes per cell for the 500 m<sup>3</sup> cells.
- The lip loading for the flotation cell is within the normal limits of <1.5 t/h/linear metre.

The following comment relates to the large 500 m<sup>3</sup> flotation cells incorporated into the design of the flotation circuit. Following on as a logical development of the very successful 300 m<sup>3</sup> large flotation cells, both Outotec and FL Smidth have conceptually designed the next generation of large flotation cells, namely flotation cells having a volume of 500 m<sup>3</sup>. Although no specific orders have been placed at this time, Outotec has apparently successfully tested a prototype unit. FL Smidth is planning to test their 500 m<sup>3</sup> cell early during 2011. It is therefore quite conceivable that 500 m<sup>3</sup> flotation cells will be in service within the next 2 to 5 years in high-tonnage throughput applications.

Therefore, specifying the 500 m<sup>3</sup> flotation cells for the Pebble Project is not considered to carry significant technical risk since, if the testing of these 500 m<sup>3</sup> cells proves to be problematical, the installation of the proven 300 m<sup>3</sup> flotation cells can be retrofitted into the design before construction commences, although there will be adjustments required to the layout of the flotation plant.

#### 16.10.7 REGRIND CIRCUIT

The flotation concentrate regrind circuit is shown to have four VTM-3000 tower mills each with a motor of 2.2 MW. The mill feed size of the concentrate is specified to be 185 µm, and the product particle size is a P<sub>80</sub> = 25 µm, and is based on the nominal feed rate of 893 ton per hour and a Bond grinding work index of 13.5 kWh/tonne, and using a regrind mill efficiency of 70%.

A further comment regarding the selection of the regrind mill is pertinent. The vertical tower regrind mill proposed for the concentrate regrind circuit is the Metso manufactured VTM-3000 model, which was not yet in commercial operation at the time the plant design was conducted. The first VTM-3000 unit, recently installed at the Cadia Valley operations in Australia, was commissioned during July 2010, and has apparently exceeded production expectations. With the successful commissioning of the prototype VTM-3000 unit, the VTM-3000 regrind mill can now be considered to be available to the industry for suitable applications such as the Pebble Project.

#### 16.10.8 1<sup>ST</sup> CLEANER CIRCUIT

The flowsheet design indicates that the 1<sup>st</sup> cleaner circuit as consisting of two rows of cells each having three cells and each cell with a volume of 100 m<sup>3</sup>. A review of the parameters used and the calculated masses as presented in the mass balance indicates that this circuit design should be adequate, since the carry rate, retention time per cell, and lip loading values are all acceptable. However, the scale-up factor from laboratory testwork to commercial plant could be reviewed in a future project iteration, as should the configuration of the cells which could result in an improved overall cleaner circuit layout.

#### 16.10.9 1<sup>ST</sup> CLEANER SCAVENGER CIRCUIT

The process design gives the 1<sup>st</sup> cleaner scavenger circuit as consisting of two rows of cells each having two cells and each cell having a volume of 100 m<sup>3</sup>. This circuit should also be reviewed as it may also be possibly under-designed for the proposed mass recovery and throughput rate.

Of note is that the 1<sup>st</sup> cleaner circuit has been designed with inter-changeable concentrate launders which can be adjusted to suit the operational conditions.

#### 16.10.10 2<sup>ND</sup> CLEANER CIRCUIT

The 2<sup>nd</sup> cleaner flotation circuit consists of six column cells. This circuit appears to be adequately designed and is considered to be best suited to attaining the final concentrate product grades required.

#### 16.10.11 2<sup>ND</sup> CLEANER SCAVENGER CIRCUIT

The design allows for four 100 m<sup>3</sup> flotation cells in the 2<sup>nd</sup> cleaner scavenger circuit in order to minimize losses from the column cell upgrading step. This circuit is adequately designed, and there may be some over-capacity in the design. A future review of the final design of the plant may result in an improved layout of this circuit.

#### 16.10.12 MOLYBDENUM FLOTATION

The residence times and cell volumes given in the design of the molybdenum recovery section appear to be acceptable, as well as the other flotation parameters such as lip loading, carry rate and cell retention time. However, given the low feed grades of the material tested and the absence of confirmatory detailed testing of the copper-molybdenum separation process, it is recommended that a bulk sample be tested to ensure that the molybdenum concentrate grade values of 52% Mo are attainable.

#### 16.10.13 MOLYBDENUM CONCENTRATE DRYING

The drying of the molybdenum concentrate at the mine site facilitates the shipping of the concentrates to smelters. The disc filter and the concentrate drying and packaging system as given in the design are conventional equipment items.

### 16.11 THICKENING

---

#### 16.11.1 BULK CONCENTRATE THICKENER

The diameter of the bulk concentrate thickener has been calculated to be 30 m and will be adequate for the bulk concentrate production rate of 150 tons per day at the solids loading rate of 2 ft<sup>2</sup>/ton/day (0.2 m<sup>2</sup>/tonne/day). Testwork has indicated that for the design underflow density of 40% solids, no flocculant addition will be required.

However, it is recommended that provision be made for a flocculant addition facility to ensure that an clear acceptable overflow solution clarity is attained at the required underflow density.

#### 16.11.2 TAILINGS THICKENER

Outotec conducted settling tests using different lithological tailings samples. The results are summarized in Table 16.11.1.

**Table 16.11.1 Results of Tailings Thickening Tests**

Sample	Feed (% Solids)	Solid Loading Rate (t/h per m <sup>2</sup> )	Flocculant Dosage (g/t)	Underflow Density (% Solids)	Overflow Density (TSS* ppm)
Illite/Pyrite	16.1	0.80 – 1.25	28 – 53	54.8 – 59.8	200 – 1680
Supergene	15.7 – 19.3	0.42 – 0.84	49 – 80	48.7 – 59.5	80 – 480
Carbonate	14.6 – 18.2	0.52 – 1.00	36 – 83	61.0 – 67.8	360 – 1960

Based on a tailings throughput of 8,052 ton per hour, a tailings thickener with a diameter of 100 m was calculated as being suitable to meet the requirements for all the samples tests. The design for the tailings thickener was stipulated to have a diameter of 120 m. The underflow density design value at 55% solids is a relatively standard density value, but the rheological characteristics should be confirmed. A relatively industry-standard flocculant addition rate of between 50 and 60 g/t has been given in the design. The behaviour of the samples indicated relatively normal settling characteristics.

Table 16.11.2 summarizes the overall conditions for the tailings thickener.

**Table 16.11.2 Tailings Thickener Parameters**

Item	Condition
Feed Density	15% of solids
Flocculant Type	Flomin 910 VHM or equivalent
Flocculant Dosage	50 to 60 g/t
Thickener Underflow Density	55% of solids
Solids Loading Rate	1.05 t/h per m <sup>2</sup>
Overflow Clarity	<2,000 ppm TSS

### 16.11.3 MOLYBDENUM CONCENTRATE THICKENER

As with the bulk concentrate thickener, using a similar solids loading value, the molybdenum concentrate thickener diameter is calculated to be 5 m. Since no data is available from the testwork programs regarding the flocculant dosages required to assist in the settling of the molybdenum concentrate, a flocculant addition facility should be included for in the design of this thickener.

### 16.11.4 MINE SITE – COPPER CONCENTRATE THICKENER

Outotec conducted testwork to characterize the settling parameters of the copper concentrate, and Table 16.20 summarizes the results obtained.

Based on the copper concentrate production rate of 146 tons per hour, the calculated thickener diameter is 29 m. The design has specified a thickener diameter of 30 m. Provision for flocculant addition should also be included in the design.

**Table 16.11.3 Copper Concentrate Thickening Parameters**

Feed (% solids)	Solid Loading Rate (t/h/m <sup>2</sup> )	Flocculant Dosage (g/t)	Underflow Density (%Solids)	Overflow Density (TSS ppm)
21.4	0.23	16	65.8	17



### 16.11.5 PORT SITE – COPPER CONCENTRATE THICKENER

Since the same conditions apply to the copper concentrate thickening at the port site as for the copper concentrate thickener at the mine site, a thickener diameter of 30 m is specified, again with provision for flocculant addition. In this case, the thickener overflow and filtrate solution will require a collection system and a pumping facility to return the solution to the mine site process water system.

### 16.11.6 COPPER CONCENTRATE FILTRATION AND STORAGE

No data has been specified for the filtration of the concentrate, and industry standard pressure filters are specified for this filtration process. However, the moisture content of the filtered concentrate is given as 8% but requires confirmatory testwork.

### 16.11.7 GRAVITY CONCENTRATION OF GOLD

The concentration of gold by centrifugal concentrators has been included in the design of the regrind circuit and is also shown on the simplified flowsheets, while a gold recovery circuit has also been included in the design. A trade-off study is recommended to determine the most effective manner of recovering the gold, namely whether by centrifugal gravity concentration or by flotation only.

## 16.12 PROCESS PLANT DESIGN RECOMMENDATIONS

---

A number of recommendations regarding the design of the process plant have been listed in the relevant sections. In summary, the major process plant design recommendations include the following:

- Confirm the flotation circuit operating slurry density value in order to finalise the flotation cell layout.
- Confirm the design parameters for the copper-molybdenum separation process.
- The copper concentrate pipeline design should be characterized in greater detail.
- The gold recovery options need to be finalised.
- An on-stream analyzer has been included in the design of the flotation circuit, together with the required particle size monitors. However, it is further recommended that the process design include froth analyzers in the various flotation stages to assist with reagent control, and assist in maintaining optimum operating conditions throughout the flotation plant.

## 16.13 SIMPLIFIED PROCESS FLOWSHEETS

---

The simplified process flowsheets are included for reference as Figure 16.13.1 to Figure 16.13.9. The simplified mass balance is given as Table 16.13.1

**Table 16.13.1 Mass Balance**

Process Description	Flow ID	Solids, t/h	Solids SG	Solids, m <sup>3</sup> /h	Water, t/h	% Solids	Water, m <sup>3</sup> /h	Pulp, t/h	Pulp SG	Pulp, m <sup>3</sup> /h
ROM Ore ( at 94% availability)		8067.4	2.63	3067.4	424.6	95.0	424.6	8492.0	2.43	3492.0
<b>Grinding Circuit</b>										
<i>SAG Mill</i>										
New Feed to SAG Mill	100	8067.4	2.63	3067.4	424.6	95.0	424.6	8492.0	2.43	3492.0
Pebble Crusher Discharge - SAG Mill Feed	102	2016.8	2.63	766.9	106.1	95.0	106.1	2123.0	2.43	873.0
Total SAG Mill Feed	104	10084.2	2.63	3834.3	530.7	95.0	530.7	10615.0	2.43	4365.1
Process Water to SAG Mill	106	0.0	1.00	0.0	3012.4	0.0	3012.4	3012.4	1.00	3012.4
SAG Mill Discharge	108	10084.2	2.63	3834.3	3543.1	74.0	3543.1	13627.3	1.85	7377.4
Lube Cooling SAG Mill to Pump box	110	0.0	1.00	0.0	5.0	0.0	5.0	5.0	1.00	5.0
<i>Discharge Screen Balance</i>										
Balance Check Calculation	114	10084.2	2.63	3834.3	8585.2	54.0	8585.2	18669.4	1.50	12419.5
Mill Discharge Screen Spray Water	116	0.0	1.00	0.0	5042.1	0.0	5042.1	5042.1	1.00	5042.1
Discharge Screen Feed	118	10084.2	2.63	3834.3	8585.2	54.0	8585.2	18669.4	1.50	12419.5
Screen Oversize/ Pebble Crusher Feed	120	2016.8	2.63	766.9	106.1	95.0	106.1	2123.0	2.43	873.0
Screen Undersize	122	8067.4	2.63	3067.4	8479.1	48.8	8479.1	16546.4	1.43	11546.5
Process Water to SAG Mill Discharge Pump Box	124	0.0	1.00	0.0	10299.4	0.0	10299.4	10299.4	1.00	10299.4
New Feed to SAG Mill/2 mills	126	4033.7	2.63	1533.7	8585.2	95.0	8585.2	12618.9	1.25	10118.9
New Feed to SAG Mill/3 mills	128	2689.1	2.63	1022.5	8585.2	95.0	8585.2	11274.3	1.17	9607.7
<i>Ball Mill</i>										
Balance Check Calculation	130	8067.4	2.63	3067.4	18823.8	30.0	18823.8	26891.1	1.23	21891.2
Cyclone Feed #1	132	32269.5	2.63	12269.8	27327.2	54.1	27327.2	59596.7	1.51	39597.0
Cyclone Overflow #1	134	8067.4	2.63	3067.4	18823.8	30.0	18823.8	26891.1	1.23	21891.2
Cyclone Underflow #1	136	24202.1	2.63	9202.3	8503.5	74.0	8503.5	32705.6	1.85	17705.8
Process Water to Ball Mill Feed	138	0.0	1.00	0.0	0.0	100.0	0.0	0.0	1.00	0.0
Ball Mill Feed	140	24202.1	2.63	9202.3	8503.5	74.0	8503.5	32705.6	1.85	17705.8
Process Spray Water to Ball Mill Discharge	142	0.0	1.00	0.0	10.0	0.0	10.0	10.0	1.00	10.0
Total Ball Mill Discharge	144	24202.1	2.63	9202.3	8513.5	74.0	8513.5	32715.6	1.85	17715.8
Ball Mill Lube Unit Water (to Pumpbox)	146	0.0	1.00	0.0	4.1	0.0	4.1	4.1	1.00	4.1
Lime to Cyclone #1 Feed Pumpbox	148	6.1	2.60	2.3	24.2	20.0	24.2	30.3	1.14	26.5
Total Feed to Cyclone #1 Feed Pump Box	150	32269.5	2.63	12269.8	27335.2	54.1	27335.2	59604.7	1.50	39605.0
GSW Cyclone #1 Feed Pump	152	0.0	1.00	0.0	2.0	0.0	2.0	2.0	1.00	2.0

Table continues...

...Table 16.13.1 (cont'd)

Process Description	Flow ID	Solids, t/h	Solids SG	Solids, m <sup>3</sup> /h	Water, t/h	% Solids	Water, m <sup>3</sup> /h	Pulp, t/h	Pulp SG	Pulp, m <sup>3</sup> /h
Total Feed to Cyclone #1 Feed (check)	154	32269.5	2.63	12269.8	27337.2	54.1	27337.2	59606.7	1.50	39607.0
Feed from Cyclone O/F to Flotation	156	8067.4	2.63	3067.4	18823.8	30.0	18823.8	26891.1	1.23	21891.2
Ball Mill Feed 2 streams (4BM)	158	6050.5	2.63	2300.6	2125.9	74.0	2125.9	8176.4	1.85	4426.4
Feed from Cyclone O/F to Flotation/ mill	160	2016.8	2.63	766.9	4705.9	30.0	4705.9	6722.8	1.23	5472.8
Ball Mill feed 3 streams (6BM)	162	4033.7	2.63	1533.7	1417.2	74.0	1417.2	5450.9	1.85	2951.0
Feed from Cyclone O/F to Flotation/mill	164	1344.6	2.63	511.2	3137.3	30.0	3137.3	4481.9	1.23	3648.5
<b>Copper Flotation Circuit</b>										
<i>Copper Rougher Flotation</i>										
Total Feed to Copper Rougher Flotation	166	8067.4	2.63	3067.4	18823.8	30.0	18823.8	26891.1	1.23	21891.2
Copper Rougher Concentrate	168	968.1	3.10	312.3	2904.3	25.0	2904.3	3872.3	1.20	3216.5
LW-Copper Rougher	170	0.0	1.00	0.0	580.9	0.0	580.9	580.9	1.00	580.9
Total Copper Rougher Concentrate	172	968.1	3.10	312.3	3485.1	21.7	3485.1	4453.2	1.17	3797.4
Copper Rougher Tailings	174	7099.3	2.63	2699.4	15919.5	30.8	15919.5	23018.8	1.24	18618.9
GSW-Copper Tailings Pumpbox	176	0.0	1.00	0.0	2.0	0.0	2.0	2.0	1.00	2.0
Total Copper Tailings	178	7931.0	2.63	3015.6	19115.6	29.3	19115.6	27046.7	1.22	22131.2
<b>Copper Concentrate Regrind</b>										
<i>Cleaner Regrind using CL</i>										
Fresh Water Cleaner Regrind Mill Lube Units	535	0.0	1.0	0.0	2.0	0.0	2.0	2.0	1.0	2.0
GSW Cleaner Regrind Cyclone Feed Pump	540	0.0	1.0	0.0	3.0	0.0	3.0	3.0	1.0	3.0
Process Water to Cleaner Regrind Mill Pumpbox	541	0.0	1.0	0.0	0.0	0.0	0.0	0.0	#DIV/0!	0.0
Cleaner Regrind Circuit Cyclone Feed	545	3,388.3	3.1	1,093.0	4,793.3	41.4	4,793.3	8,181.6	1.4	5,886.3
Cleaner Regrind Cyclone U/F	550	2,420.2	3.1	780.7	1,303.2	65.0	1,303.2	3,723.4	1.8	2,083.9
Cleaner Regrind Cyclone O/F	555	1,048.0	3.1	338.0	3,490.1	23.1	3,490.1	4,538.1	1.2	3,828.2
<i>Cleaner Regrind using Densifying</i>										
Process Water to Copper Cyclone Feed Pump Box	180	0.0	1.00	0.0	0.0	100.0	0.0	0.0	1.00	0.0
GSW - Copper Regrind Cyclone Pump	182	0.0	1.00	0.0	1.0	0.0	1.0	1.0	1.00	1.0
Total Feed to Copper Regrind Cyclone	188	1048.0	3.10	338.0	3760.3	21.8	3760.3	4808.3	1.17	4098.4
Copper Regrind Cyclone U/F to SMD	190	790.4	3.10	255.0	790.4	50.0	790.4	1580.9	1.51	1045.4
Copper Regrind Cyclone O/F to Pumpbox	192	257.5	3.10	83.1	2969.9	8.0	2969.9	3227.4	1.06	3053.0
GSW – Copper Regrind Pumpbox	194	0.0	1.00	0.0	1.0	0.0	1.0	1.0	1.00	1.0

Table continues...

...Table 16.13.1 (cont'd)

Process Description	Flow ID	Solids, t/h	Solids SG	Solids, m <sup>3</sup> /h	Water, t/h	% Solids	Water, m <sup>3</sup> /h	Pulp, t/h	Pulp SG	Pulp, m <sup>3</sup> /h
Copper Regrind Mill Discharge to Copper 1 <sup>st</sup> Cleaners	196	1048.0	3.10	338.0	3761.3	21.8	3761.3	4809.3	1.17	4099.4
<i>Copper 1<sup>st</sup> Cleaner Flotation</i>										
Total Feed to Copper 1st Cleaners	206	1137.5	3.10	366.9	4110.2	21.7	4110.2	5247.7	1.17	4477.1
Copper 1 <sup>st</sup> Cleaner Flotation Concentrate	208	225.9	3.50	64.5	677.7	25.0	677.7	903.5	1.22	742.2
LW Copper 1 <sup>st</sup> Cleaners	210	0.0	1.00	0.0	135.5	0.0	135.5	135.5	1.00	135.5
Total Copper 1 <sup>st</sup> Cleaner Concentrate	212	225.9	3.50	64.5	813.2	21.7	813.2	1039.1	1.18	877.7
Copper 1 <sup>st</sup> Cleaner Tailings	214	911.6	3.00	303.9	3432.5	21.0	3432.5	4344.1	1.16	3736.4
<i>Copper 1<sup>st</sup> Cleaner Scavenger Flotation</i>										
Total Feed to Copper 1st Cleaner Scavengers	220	911.6	3.00	303.9	3433.7	21.0	3433.7	4345.3	1.16	3737.6
Copper 1 <sup>st</sup> Cleaner Scavenger Concentrate	222	79.9	3.00	26.6	239.6	25.0	239.6	319.5	1.20	266.2
LW Copper 1 <sup>st</sup> Cleaner Scavengers	224	0.0	1.00	0.0	31.9	0.0	31.9	31.9	1.00	31.9
Total Copper 1 <sup>st</sup> Cleaner Scavenger Concentrate	226	79.9	3.00	26.6	271.5	22.7	271.5	351.4	1.18	298.2
Copper 1 <sup>st</sup> Cleaner Scavenger Tailings	228	831.7	3.00	277.2	3194.1	20.7	3194.1	4025.9	1.16	3471.4
<i>Copper 2<sup>nd</sup> Cleaner Flotation</i>										
Process Water	485	0.0	1.00	0.0	60.0	0.0	60.0	60.0	1.00	60.0
Total Feed to Copper 2 <sup>nd</sup> Cleaners	236	260.0	3.60	72.2	991.3	20.8	991.3	1251.3	1.18	1063.5
Copper 2 <sup>nd</sup> Cleaner Concentrate	238	136.3	3.80	35.9	545.4	20.0	545.4	681.7	1.17	581.2
LW Copper 2 <sup>nd</sup> Cleaner Flotation	240	0.0	1.00	0.0	54.5	0.0	54.5	54.5	1.00	54.5
Total Copper 2 <sup>nd</sup> Cleaner Concentrate	242	136.3	3.80	35.9	599.9	18.5	599.9	736.2	1.16	635.8
Copper 2 <sup>nd</sup> Cleaner Tailings	244	123.7	3.60	34.4	445.9	21.7	445.9	569.6	1.19	480.3
GSW - Copper 2 <sup>nd</sup> Cleaner Tailings Pump	246	0.0	1.00	0.0	0.2	0.0	0.2	0.2	1.00	0.2
Total Copper 2 <sup>nd</sup> Cleaner Tailings	248	123.7	3.60	34.4	446.1	21.7	446.1	569.8	1.19	480.5
<i>Copper 2<sup>nd</sup> Cleaner Scavenger Flotation</i>										
Total Feed to Copper 2 <sup>nd</sup> Cleaner Scavengers	254	123.7	3.00	41.2	446.6	21.7	446.6	570.3	1.17	487.8
Copper 2 <sup>nd</sup> Cleaner Scavenger Concentrate	256	34.1	3.00	11.4	102.4	25.0	102.4	136.5	1.20	113.8
LW Copper 2 <sup>nd</sup> Cleaner Scavengers	258	0.0	1.00	0.0	13.7	0.0	13.7	13.7	1.00	13.7
Total Copper 2 <sup>nd</sup> Cleaner Scavenger Concentrate	260	34.1	3.00	11.4	116.0	22.7	116.0	150.2	1.18	127.4
Copper 2 <sup>nd</sup> Cleaner Scavenger Tailings	262	89.5	3.00	29.8	344.2	20.6	344.2	433.8	1.16	374.1
<b>Bulk Cu/Mo Concentrate Thickening</b>										
Feed to Concentrate Thickener	960	136.3	3.80	35.9	599.9	18.5	599.9	736.2	1.16	635.8
Total Feed to Concentrate Thickener	965	136.3	3.80	35.9	599.9	18.5	599.9	736.2	1.16	635.8

Table continues...

...Table 16.13.1 (cont'd)

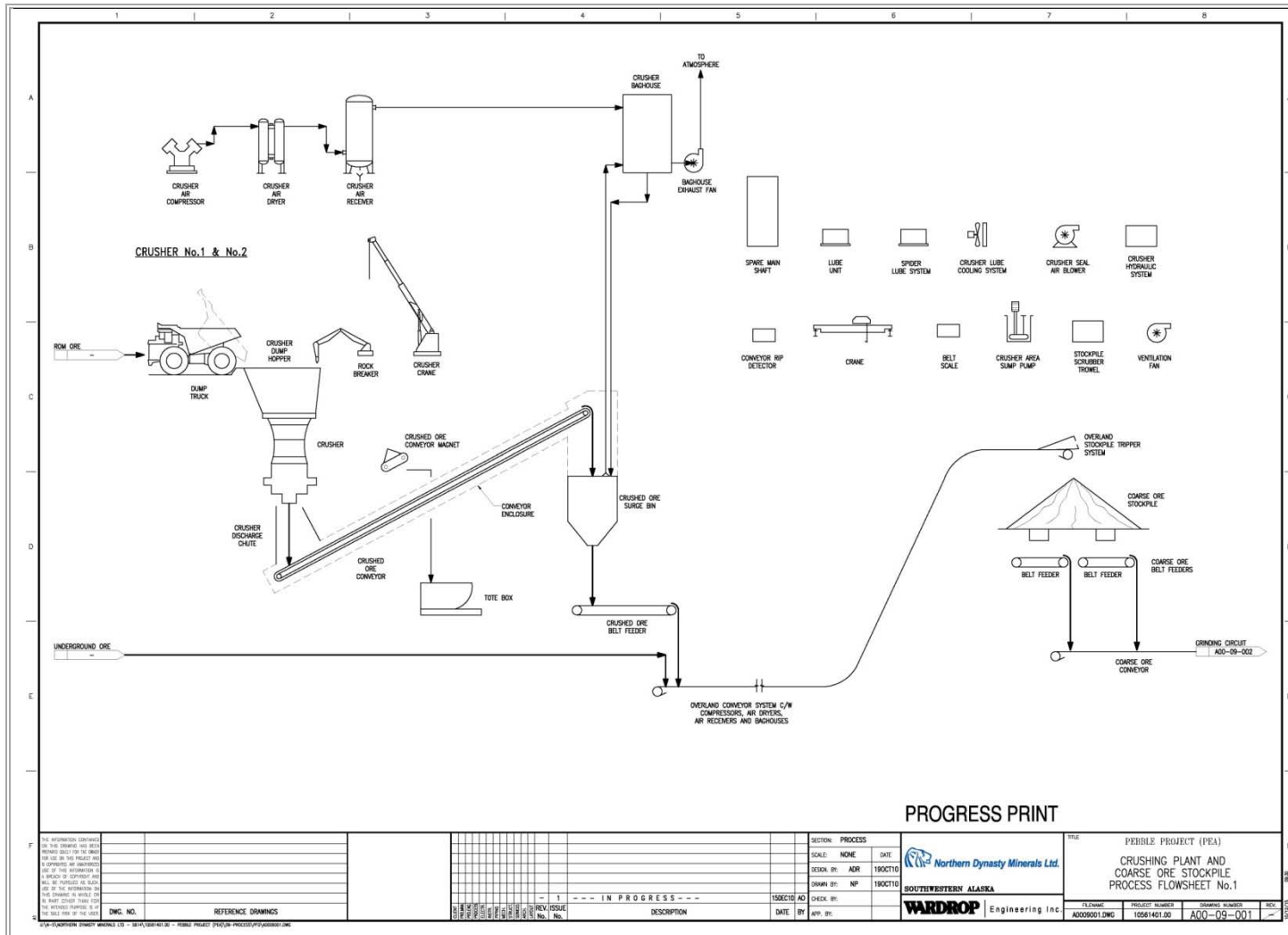
Process Description	Flow ID	Solids, t/h	Solids SG	Solids, m <sup>3</sup> /h	Water, t/h	% Solids	Water, m <sup>3</sup> /h	Pulp, t/h	Pulp SG	Pulp, m <sup>3</sup> /h
Concentrate Thickener U/F	970	136.3	3.80	35.9	118.5	53.5	118.5	254.8	1.65	154.4
Concentrate Thickener O/F	975	0.0	1.00	0.0	481.4	0.0	481.4	481.4	1.00	481.4
GSW Thickener Overflow Standpipe Pump	980	0.0	1.00	0.0	0.5	0.0	0.5	0.5	1.00	0.5
<b>Molybdenum Flotation</b>										
<i>Molybdenum Rougher Flotation</i>										
Cu Concentrate Thickener O/F to Mo Rougher Flotation	1000				50.0		50.0			
Feed to Molybdenum Flotation Conditioning Tank	1005	179.9	3.80	47.3	258.9	41.0	258.9	438.8	1.43	306.2
Total feed to Molybdenum Rougher Flotation	1030	179.9	3.80	47.3	258.9	41.0	258.9	438.8	1.43	306.2
Molybdenum Rougher Concentrate	1035	13.7	4.20	3.3	41.1	25.0	41.1	54.9	1.24	44.4
Molybdenum Rougher Concentrate Launder Water	1040	0.0	1.00	0.0	8.2	0.0	8.2	8.2	1.00	8.2
Molybdenum Rougher Tailings	1045	166.2	3.70	44.9	217.7	43.3	217.7	383.9	1.46	262.7
Molybdenum Rougher Concentrate	1055	13.7	3.90	3.5	49.4	21.7	49.4	63.1	1.19	52.9
Molybdenum Scavenger Concentrate	1035	33.9	4.20	8.1	101.6	25.0	101.6	135.5	1.24	109.7
Molybdenum Scavenger Concentrate LW	1040	0.0	1.00	0.0	20.3	0.0	20.3	20.3	1.00	20.3
Molybdenum Scavenger Tailings (Cu Concentrate)	1045	132.3	3.80	34.8	116.1	53.3	116.1	248.4	1.65	150.9
Molybdenum Scavenger Concentrate	1055	33.9	4.20	8.1	122.0	21.7	122.0	155.9	1.20	130.0
Feed to 1 <sup>st</sup> Cleaner Column Flotation	1124	23.8	3.50	6.8	61.5	27.9	61.5	85.3	1.25	68.3
Spray Water to 1 <sup>st</sup> Cleaner Column Flotation	1125	0.0	1.00	0.0	7.0	0.0	7.0	7.0	1.00	7.0
Total Feed to 1 <sup>st</sup> Cleaner Column Flotation	1130	23.8	3.50	6.8	68.5	25.8	68.5	92.3	1.23	75.3
1 <sup>st</sup> Mo Cleaner Concentrate	1135	6.1	3.70	1.6	18.2	25.0	18.2	24.2	1.22	19.8
Concentrate LW	1140	0.0	1.00	0.0	3.6	0.0	3.6	3.6	1.00	3.6
Total 1 <sup>st</sup> Mo Cleaner Concentrate	1145	6.1	3.70	1.6	21.8	21.7	21.8	27.8	1.19	23.4
Mo 1 <sup>st</sup> Cleaner Tailings	1150	17.7	3.50	5.1	50.3	26.1	50.3	68.1	1.23	55.4
Molybdenum 1 <sup>st</sup> Cleaner Scavenger Concentrate	1105	8.1	1.75	4.6	18.8	30.0	18.8	26.9	1.15	23.4
Molybdenum 1 <sup>st</sup> Cleaner Scavenger Concentrate LW	1110	0.0	1.00	0.0	4.8	0.0	4.8	4.8	1.00	4.8
Molybdenum 1 <sup>st</sup> Cleaner Scavenger Tailings (to mo rougher flotation)	1115	9.7	3.70	2.6	31.5	23.5	31.5	41.2	1.21	34.1
Total Molybdenum 1 <sup>st</sup> Cleaner Scavenger Tailings	1117	9.7	3.70	2.6	31.5	23.5	31.5	41.2	1.21	34.1
Molybdenum Scavenger Concentrate Standpipe	1120	8.1	1.75	4.6	23.7	25.4	23.7	31.7	1.12	28.3
Feed to 2 <sup>nd</sup> Cleaner Column Flotation	1164	6.1	3.70	1.6	21.8	21.7	21.8	27.8	1.19	23.4
Spray Water to 2 <sup>nd</sup> Cleaner Column Flotation	1165	0.0	1.00	0.0	3.5	0.0	3.5	3.5	1.00	3.5
Total Feed to 2 <sup>nd</sup> Cleaner Column Flotation	1170	6.1	3.70	1.6	25.3	19.3	25.3	31.3	1.16	26.9

Table continues...

...Table 16.13.1 (cont'd)

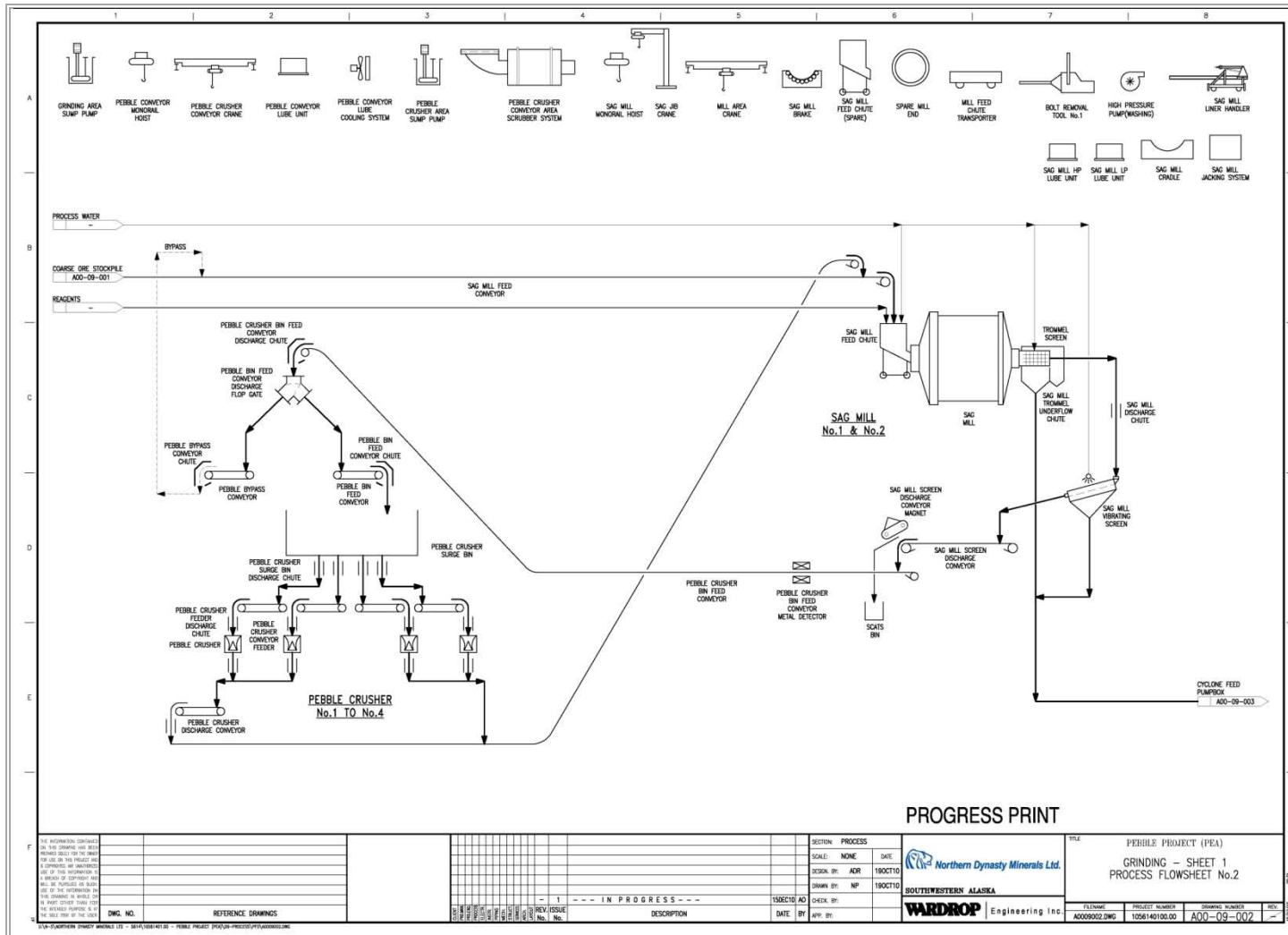
Process Description	Flow ID	Solids, t/h	Solids SG	Solids, m <sup>3</sup> /h	Water, t/h	% Solids	Water, m <sup>3</sup> /h	Pulp, t/h	Pulp SG	Pulp, m <sup>3</sup> /h
2 <sup>nd</sup> Cleaner Concentrate	1175	4.03	3.90	1.0	12.1	25.0	12.1	16.1	1.23	13.1
Concentrate LW	1180	0.0	1.00	0.0	2.4	0.0	2.4	2.4	1.00	2.4
Total 2 <sup>nd</sup> Mo Cleaner Concentrate	1185	4.0	3.90	1.0	14.5	21.7	14.5	18.6	1.19	15.6
2 <sup>nd</sup> Cleaner Tailings	1190	2.0	3.60	0.6	13.2	13.3	13.2	15.2	1.11	13.7
GSW Mo 2 <sup>nd</sup> Cleaner Tailings	1195	0.0	1.00	0.0	0.0	0.0	0.0	0.0	1.00	0.0
Total Mo 2 <sup>nd</sup> Cleaner Tailings	1200	2.0	3.60	0.6	1.5	57.0	1.5	3.5	1.70	2.1

Figure 16.13.1 Crushing Plant and Coarse Ore Stockpile Process Flowsheet



1056140100-REP-R0001-00

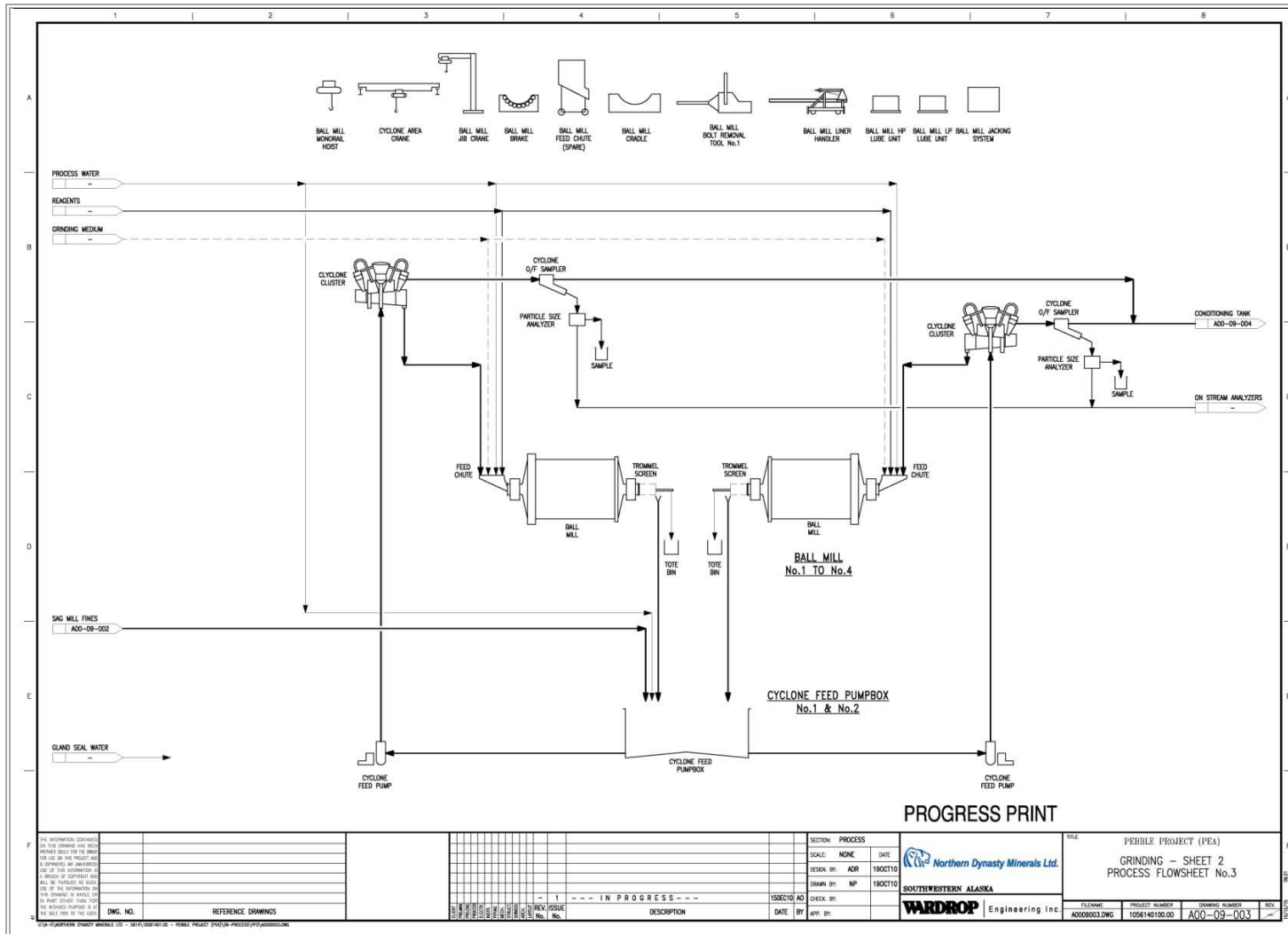
Figure 16.13.2 Grinding Process Flowsheet – Sheet 1



1056140100-REP-R0001-00

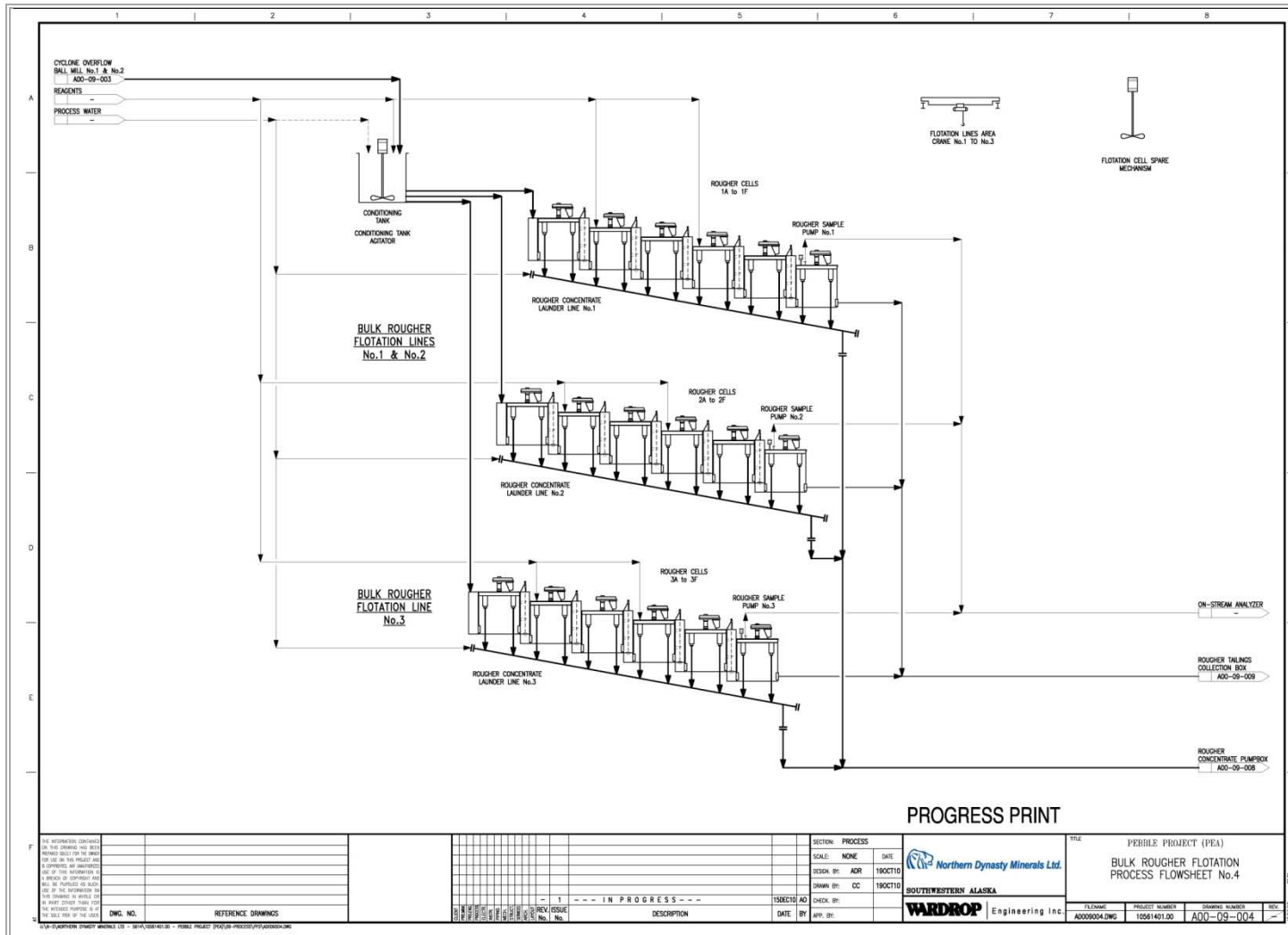


Figure 16.13.3 Grinding Process Flowsheet – Sheet 2



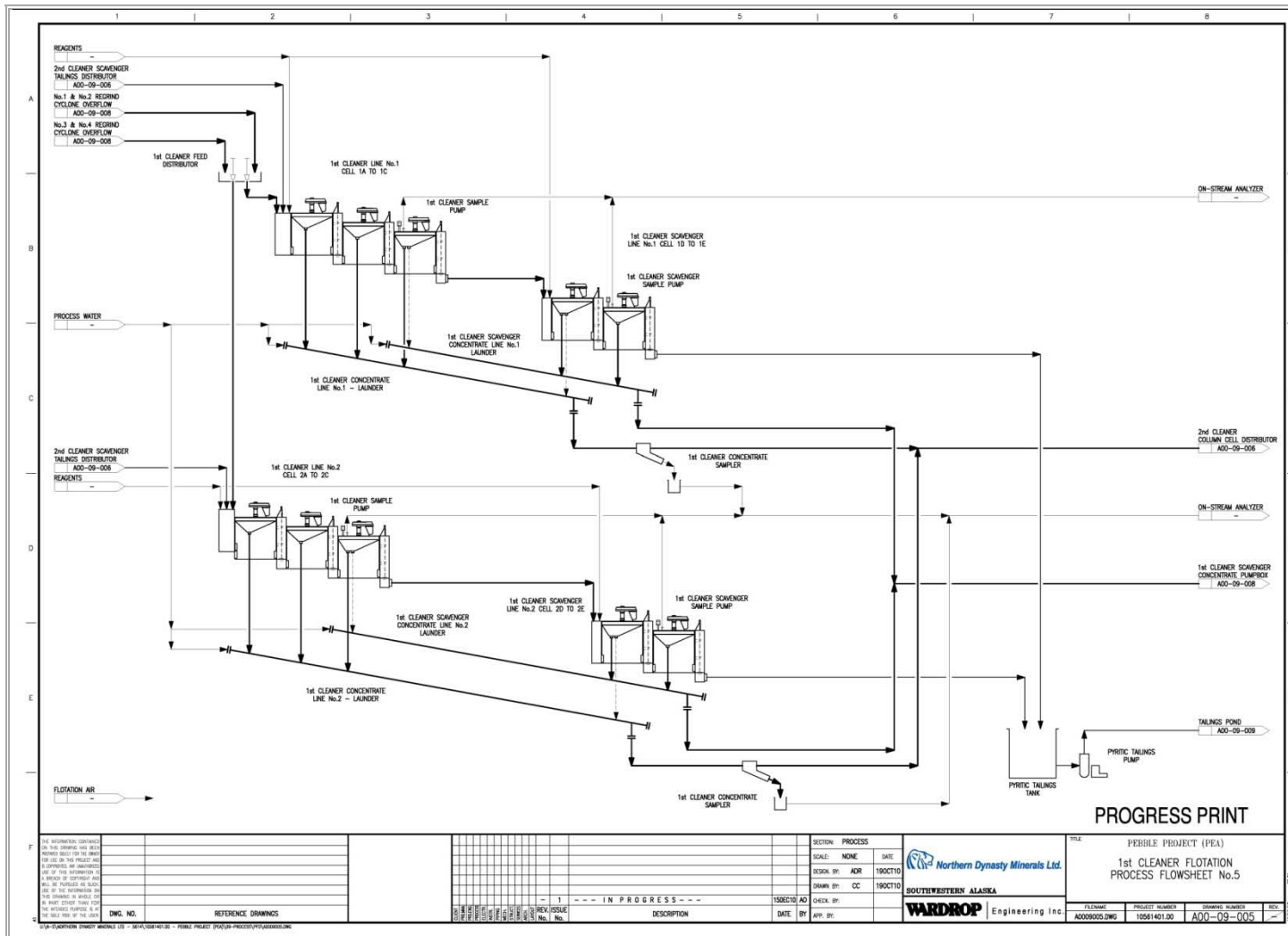
1056140100-REP-R0001-00

Figure 16.13.4 Bulk Rougher Flotation Process Flowsheet



1056140100-REP-R0001-00

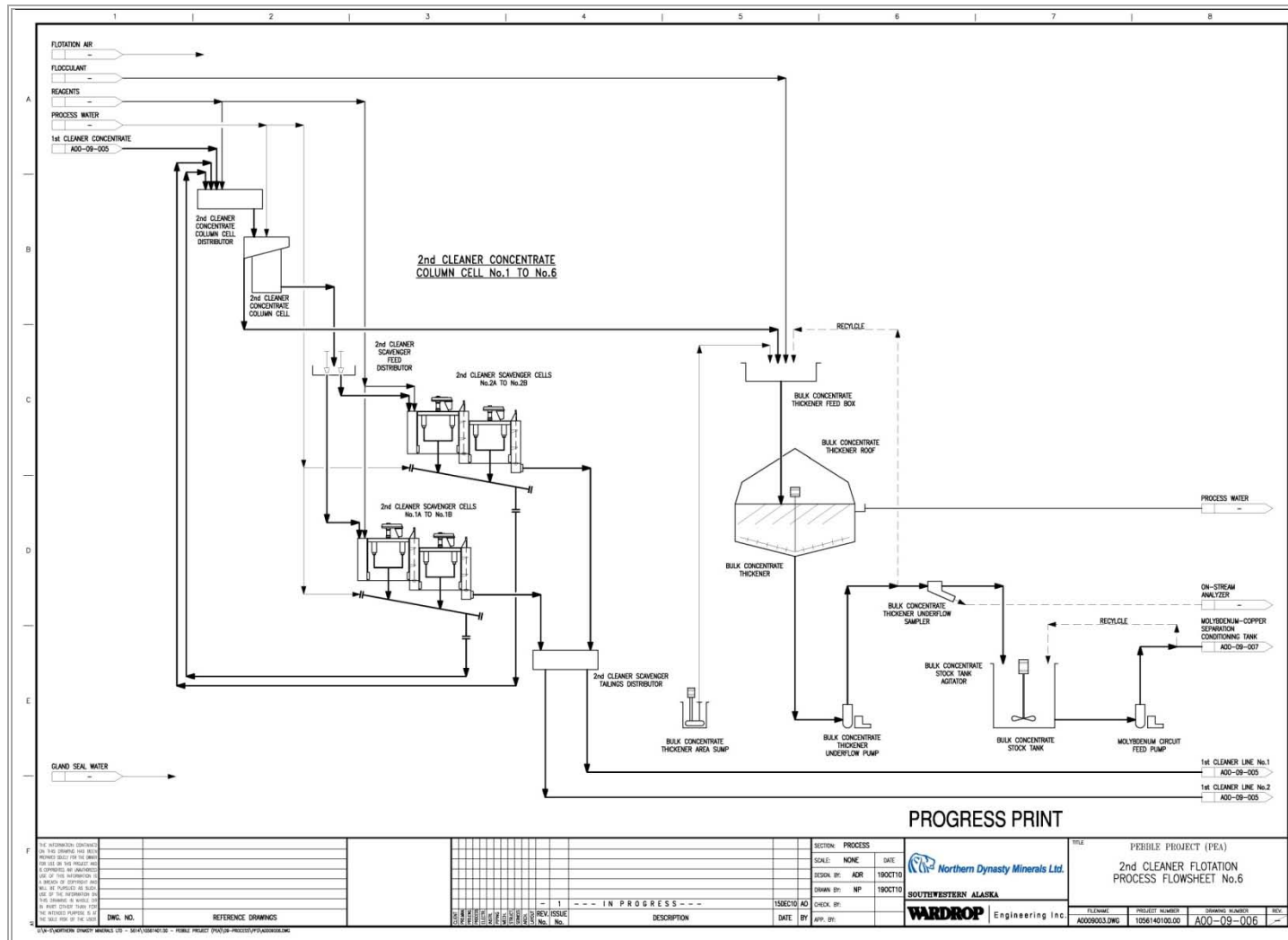
Figure 16.13.5 1<sup>st</sup> Cleaner Flotation Process Flowsheet



1056140100-REP-R0001-00

Northern Dynasty Minerals Ltd.  
Preliminary Assessment of the Pebble Project, Southwest Alaska

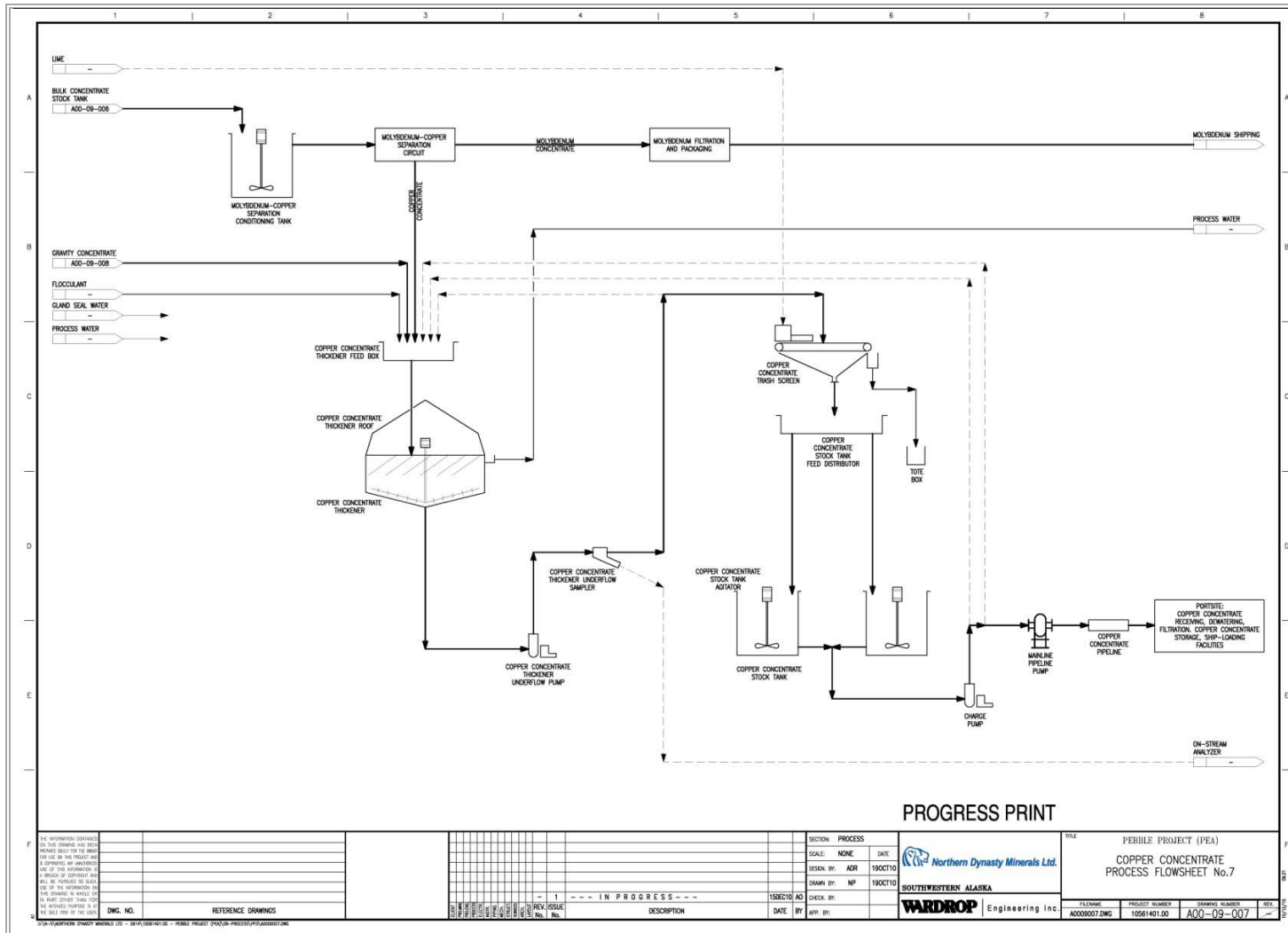
Figure 16.13.6 2<sup>nd</sup> Cleaner Flotation Process Flowsheet



1056140100-REP-R0001-00

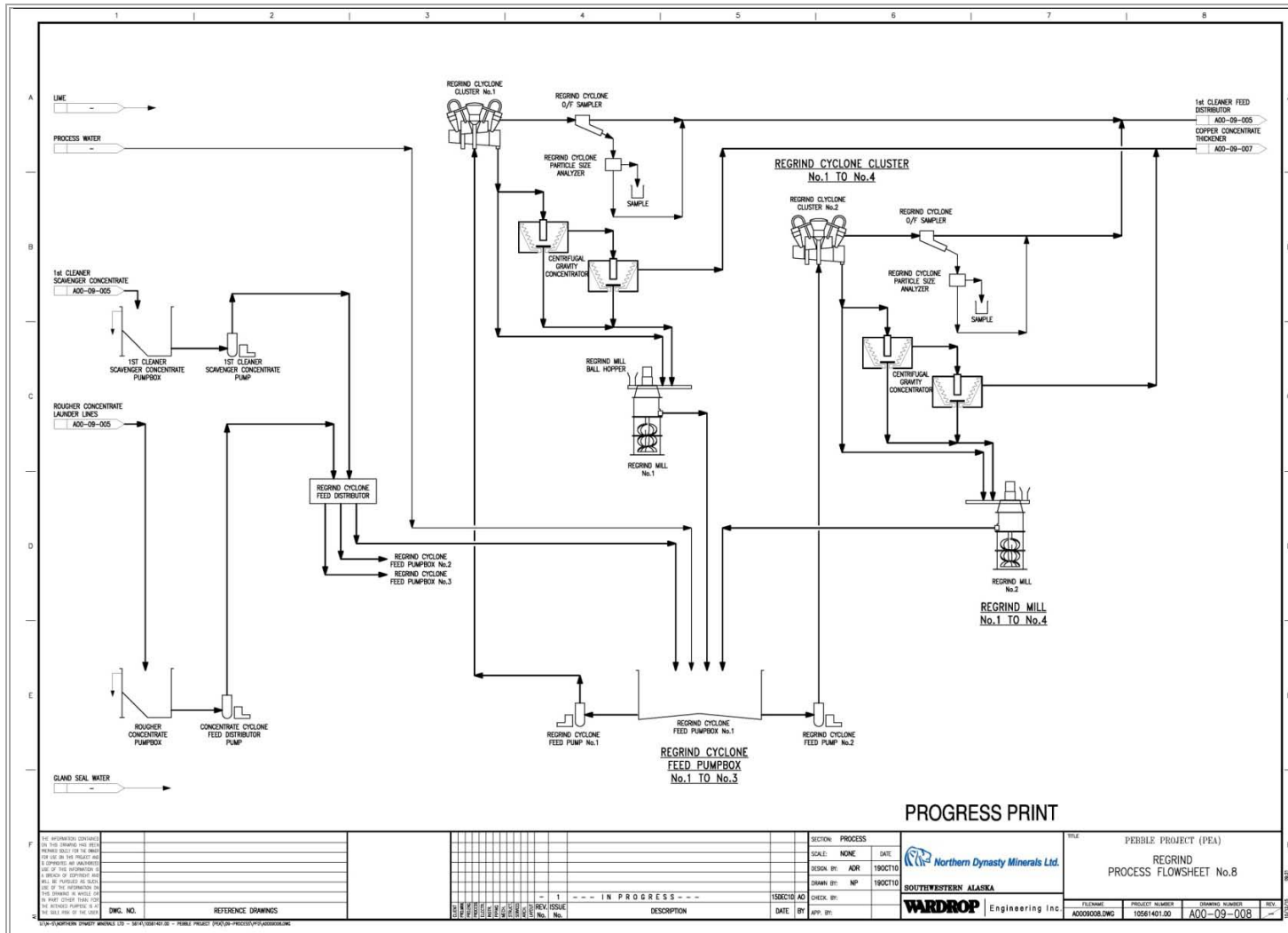
Northern Dynasty Minerals Ltd.  
Preliminary Assessment of the Pebble Project, Southwest Alaska

Figure 16.13.7 Copper Concentrate Process Flowsheet



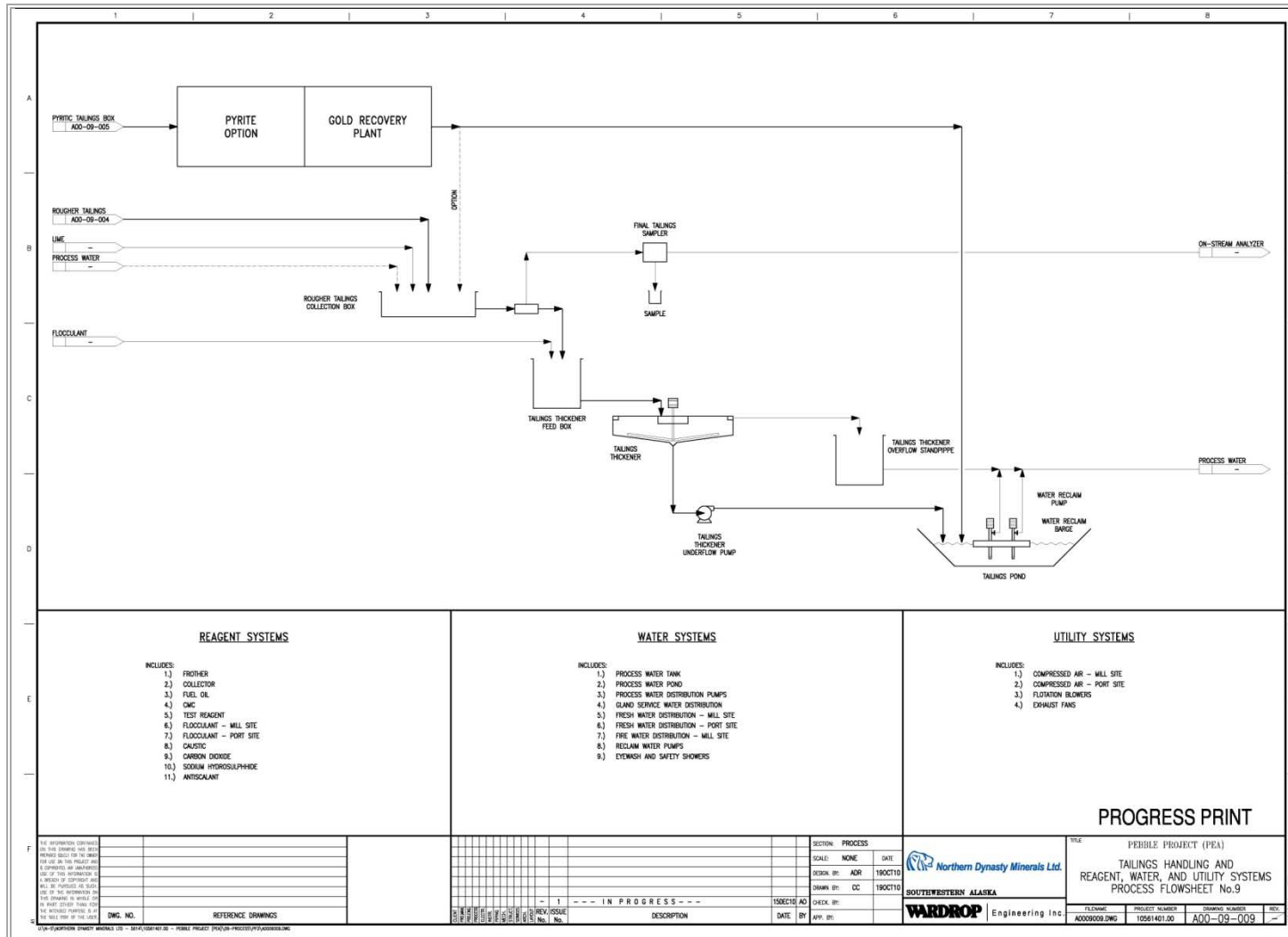
1056140100-REP-R0001-00

Figure 16.13.8 Regrind Process Flowsheet



1056140100-REP-R001-00

Figure 16.13.9 Tailings Handling and Reagent, Water, and Utility Systems Process Flowsheet



1056140100-REP-R0001-00





## 17.0 MINERAL RESOURCE AND MINERAL RESERVE ESTIMATES

### 17.1 SUMMARY AND RESOURCE DECLARATION

The current Pebble resource represents the culmination of seven years of geological and geostatistical analysis and is based on drill data to September 2009. The mineral resources are based on an February 2010 estimate for the Pebble Partnership by J. David Gaunt, P.Ge., Hunter Dickinson Inc., and audited by Robert Morrison, P.Ge., of Wardrop, a Qualified Person who is independent of Northern Dynasty and responsible for the estimate in this report. The resource is estimated in by Northern Dynasty using Maptek® Vulcan software v8.0.3 and grade is interpolated into the blocks using ordinary kriging (OK). Top cuts are applied to the raw drill hole data which is then composited prior to interpolation. Principal economic metals estimated into the blocks are copper, gold and molybdenum. Other grades and metrics are estimated into the model for metallurgical, comminution or environmental purposes. Table 17.1.1 summarizes the current Mineral Resource estimate for the Pebble deposit.

**Table 17.1.1 February 2010 Mineral Resource Estimate\***

Cut-off (% CuEQ)	CuEQ (%)	Mt	Cu (%)	Au (g/t)	Mo (ppm)	Cu (Bib)	Au (Moz)	Mo (Bib)	CuEq (Bib)
<b>Measured</b>									
0.30	0.65	527	0.33	0.35	178	3.8	5.9	0.21	7.6
0.40	0.66	508	0.34	0.36	180	3.8	5.9	0.20	7.4
0.60	0.77	277	0.40	0.42	203	2.4	3.7	0.12	4.7
1.00	1.16	27	0.62	0.62	301	0.4	0.5	0.02	0.7
<b>Indicated</b>									
0.30	0.80	5,414	0.43	0.35	257	51.3	60.9	3.07	95.5
0.40	0.85	4,891	0.46	0.36	268	49.6	56.6	2.89	91.7
0.60	1.00	3,391	0.56	0.41	301	41.9	44.7	2.25	74.8
1.00	1.30	1,422	0.77	0.51	342	24.1	23.3	1.07	40.7
<b>Measured + Indicated</b>									
0.30	0.78	5,942	0.42	0.35	250	55.0	66.9	3.28	102.2
0.40	0.83	5,399	0.45	0.36	260	53.6	62.5	3.09	98.8
0.60	0.98	3,668	0.55	0.41	293	44.5	48.3	2.37	79.2
1.00	1.29	1,449	0.76	0.52	341	24.3	24.2	1.09	41.2
<b>Inferred</b>									
0.30	0.53	4,835	0.24	0.26	215	25.6	40.4	2.29	56.5
0.40	0.66	2,845	0.32	0.30	259	20.1	27.4	1.62	41.4
0.60	0.89	1,322	0.48	0.37	289	14.0	15.7	0.84	25.9
1.00	1.20	353	0.69	0.45	379	5.4	5.1	0.29	9.3

\* this table is subject to the notes on the following page:

**Note 1:** Copper equivalent calculations used metal prices of US\$1.85/lb for copper, US\$902/oz for gold and US\$12.50/lb for molybdenum, and metallurgical recoveries of 85% for copper 69.6% for gold, and 77.8% for molybdenum in the Pebble West area and 89.3% for copper, 76.8% for gold, 83.7% for molybdenum in the Pebble East area. Revenue is calculated for each metal based on grades, recoveries, and selected metal prices; accumulated revenues are then divided by the revenue at 1% Cu. Recoveries for gold and molybdenum are normalized to the copper recovery as follows:

$$\text{CuEQ (Pebble West)} = \text{Cu \%} + (\text{Au g/t} \times 69.6\%/85\% \times 29.00/40.79) + (\text{Mo \%} \times 77.8\%/85\% \times 75.58/40.79)$$

$$\text{CuEQ (Pebble East)} = \text{Cu \%} + (\text{Au g/t} \times 76.8\%/89.3\% \times 29.00/40.79) + (\text{Mo \%} \times 83.7\%/89.3\% \times 75.58/40.79)$$

**Note 2:** By prescribed definition, “Mineral Resources” do not have demonstrated economic viability. Measured and Indicated Resources are that part of a mineral resource for which quantity and grade can be estimated with a level of confidence sufficient to allow the application of technical and economic parameters to support mine planning and evaluation of the economic viability of the project. Inferred Mineral Resources are that part of a mineral resource for which quantity and grade can be estimated on the basis of geological evidence and limited sampling and reasonably assumed, but not verified, geological and grade continuity. Inferred Mineral Resources are considered to be too speculative to allow the application of technical and economic parameters to support mine planning and evaluation of the economic viability of the project. The mineral resources fall within a volume or shell defined by long-term metal price estimates of US\$2.50/lb for copper, US\$900/lb for gold and US\$25/lb for molybdenum.

**Note 3:** For bulk underground mining, cut-offs such as 0.60% CuEQ, are typically used for porphyry deposit bulk underground mining operations at copper porphyry deposits located around the world. A 0.3% CuEQ cut-off is considered to be comparable to that used for porphyry deposit open pit mining operations in the Americas. All mineral resource estimates and cut-offs are subject to a feasibility study.

**Note 4:** CIM definition standards for Mineral Resources and Mineral Reserves were followed for resource (CIM Definition Standards dated November 22, 2005, and adopted by CIM Council on December 11, 2005).

## 17.2 DOMAINS OF THE PEBBLE DEPOSIT

---

A hybrid approach to partitioning the Pebble mineralized domains has been adopted that employs a nominated grade threshold conditioned by lithological and alteration data, and supported by data statistics. In this manner copper, gold and molybdenum are partitioned into high and low grade domains using thresholds indicated in part by descriptive statistics for the individual metals, and in part by inspection of the drill data on sections.

The basic high/low grade domains for copper, gold and molybdenum have been further modified by the East/West-trending, post ore, ZE normal fault that displaces mineralized Cretaceous rock up to 1,000 ft sub-vertically, and by a North-South trending “East-West Divide” which marks a slight change in the dip of the mineralized package.

The solid wireframes used to differentiate domains consist of both surfaces and 3D solids constructed by marking boundaries in drill hole intercepts and linking them together with poly-lines. Irregularities in the rough wireframes were smoothed by splining, but at the same time are forced to honour the individual drill hole intercepts.

With one exception, the resulting models are employed as hard boundaries in the grade estimation. The “East-West Divide” (as described above) represents the only soft boundary.

The principal domains (i.e. for copper, gold and molybdenum) are summarized in the following sections.

## 17.2.1 COPPER

### LEACHED ZONE

The leached zone (cuzone = 1) comprises a shallow blanket over the northwest part of the west zone, within which primary hypogene sulphide mineralization has been removed by weathering, with attendant reduction of copper grades. The zone measures approximately 5,000 ft long x 5,000 ft wide and averages 50 to 100 ft in thickness. It occurs only in Cretaceous rocks that are not covered by Tertiary overburden. Locally, very minor malachite, chrysocolla, native copper and/or other secondary copper minerals occur in the leached zone.

### SUPERGENE

The supergene zone (cuzone = 2) is located stratigraphically below the leach cap. It is a weakly-developed zone of enrichment measuring approximately 6000 ft x 6000 ft in extent and 150 to 200 ft thick. Principal copper minerals within the supergene blanket are chalcocite, covellite and chalcopyrite.

### HYPOGENE

The copper grades are observed to be highest in the core of the eastern zone (cuzone = 42 and 43), diminishing somewhat and becoming slightly less continuous in the west (cuzone = 41). The copper content is observed to decrease with depth, roughly coincident with the upper boundary of a strong propylitic alteration zone. A wireframe surface was constructed at this interface and serves as a hard boundary for the base of the copper mineralization. The actual wireframe surface derived is a grade shell, defined by a nominal 0.15% Cu cut-off in the west and a 0.25% Cu cut-off in the east.

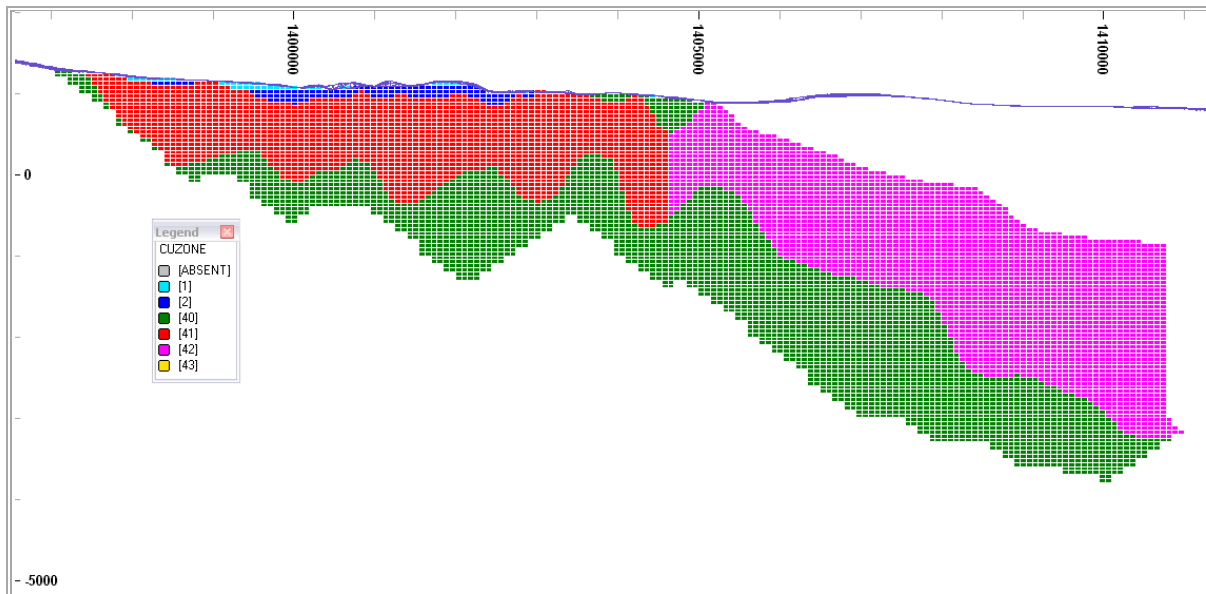
North of the east zone copper mineralization (Domain 42) is observed to be roughly concordant with granodiorite sills, bounded on the north and east by strong quartz-sericite-pyrite (QSP) alteration. A steeply dipping wireframe surface, which represents the boundary of this alteration, was constructed for the north and east side of the deposit.

A small zone of lower grade copper mineralization, thought to be related to QSP alteration, is interpreted on the south side of the deposit, near the EW Divide (cuzone = 44).

**Table 17.2.1 Copper Domain Codes**

Code	Name	Description
99	Overburden	Overburden Soils
0	Tertiary	Tertiary Rocks
1	Leached	Leached Cap Zone
2	Supergene	Supergene Enrichment Zone
40	Hypogene Low-grade	Hypogene outside the Mineralized Envelope
41	Hypogene West	Hypogene in Pebble West
42	Hypogene Northeast	Hypogene in Pebble East, north of ZE Fault
43	Hypogene Southeast	Hypogene in Pebble East, south of ZE Fault
44	Hypogene 6348	Hypogene in 6348 Block

Figure 17.2.1 Copper Domains of the Pebble Block Model (West-East) at 2157000 ft North



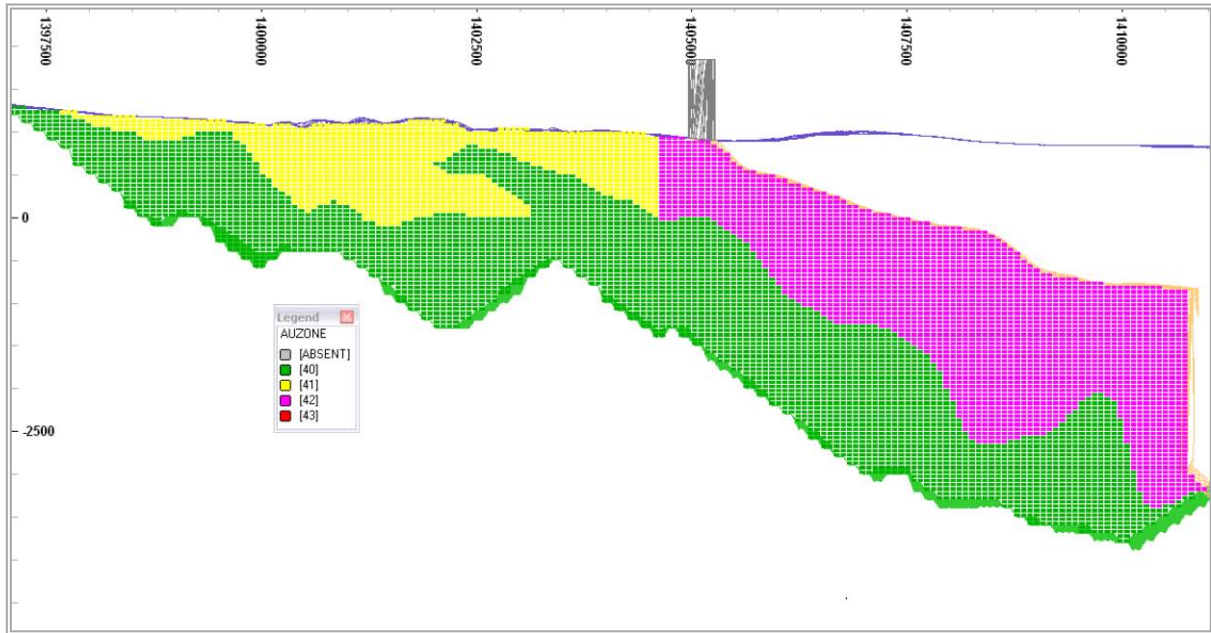
### 17.2.2 GOLD

The base of the gold zone is also thought to coincide with the boundary of propylitic alteration, and a 0.15 g/t of gold grade shell has been constructed at about this level for the lower contact. A low grade zone is observed to exist in the west zone in association with the contact between a diorite sill and metasediments (auzone = 40). The metasedimentary rocks are interpreted to be of lower permeability, essentially blocking mineralizing fluids from migrating into the area.

Table 17.2.2 Gold Domain Codes

Code	Name	Description
99	Overburden	Overburden Soils
0	Tertiary	Tertiary Rocks
40	Low-grade West	Samples below the 0.15 g/t surface West
40	Low-grade Northeast	Samples below the 0.15 g/t surface East, north of the ZE Fault
40	Low-grade Southeast	Samples below the 0.15 g/t surface East, south of the ZE Fault
41	High-grade West	Samples above the 0.15 g/t surface West
42	High-grade Northeast	Samples above the 0.15 g/t surface East, north of the ZE Fault
43	High-grade Southeast	Samples above the 0.15 g/t surface East, south of the ZE Fault
44	Hypogene 6348	Hypogene in 6348 Block

**Figure 17.2.2 Gold Domains of the Pebble Block Model (West-East) at 2157000 ft North**



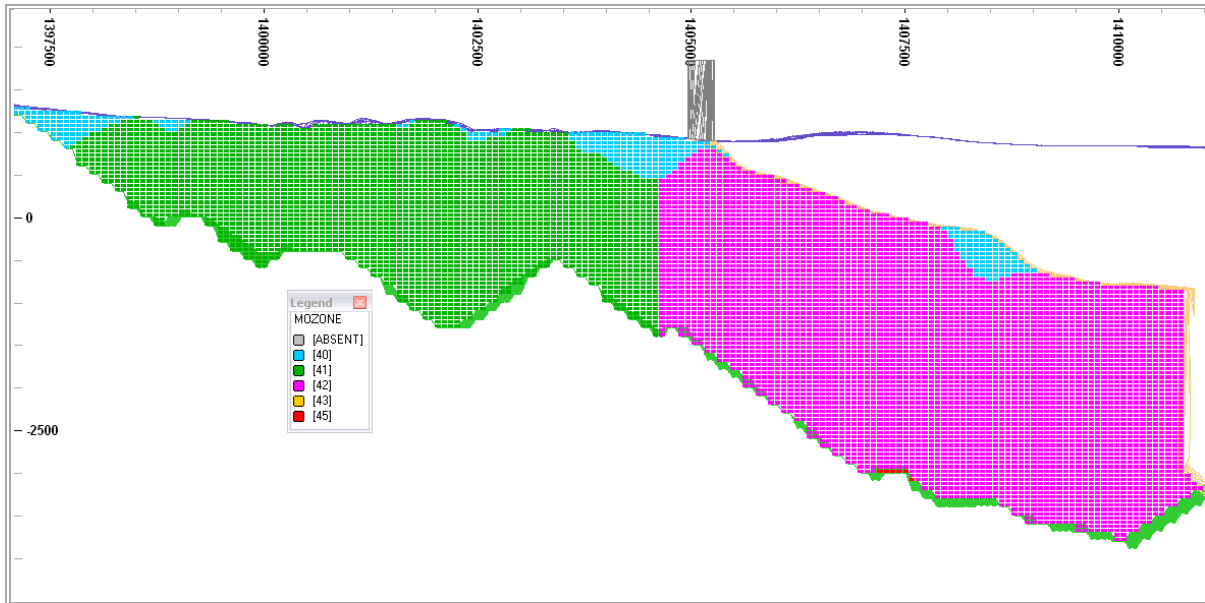
**17.2.3 MOLYBDENUM**

The molybdenum grade distribution is observed to be highest in the east (mozone = 42 and 43), becoming less continuous and lower overall to the west. In general, the molybdenum appears to be more widespread than either gold or copper. The upper boundary is deemed to be the 70 ppm cut-off. This boundary also coincides with the QSP alteration to the north and east of the east zone, similar to that for copper. At depth in the east zone, seven drill holes intersected lower grade molybdenum mineralization, and from these intercepts a lower boundary surface, also at 70 ppm, was constructed (mozone = 45).

**Table 17.2.3 Molybdenum Domain Codes**

Code	Name	Description
99	Overburden	Overburden Soils
0	Tertiary	Tertiary Rocks
40	Low-grade West	Samples below the 70 ppm cap West
40	Low-grade Northeast	Samples below the 70 ppm cap East, north of the ZE Fault
40	Low-grade Southeast	Samples below the 70 ppm cap East, south of the ZE Fault
41	High-grade West	Samples above the 70 ppm cap West
42	High-grade Northeast	Samples above the 70 ppm cap East, north of the ZE Fault
43	High-grade Southeast	Samples above the 70 ppm cap East, south of the ZE Fault
44	Hypogene 6348	Hypogene in 6348 Block
45	Low-grade Bottom	Samples below the base cap

**Figure 17.2.3 Molybdenum Domains (MOZONE) of the Pebble Block Model (West-East) at 2157000 ft North**



### 17.3 EXPLORATORY DATA ANALYSIS

Drill hole data and block model data for the resource estimate have been imported into Datamine™ software (version 3.19.3638) from text files supplied by Northern Dynasty. These text files contain resource data used in the December 2009 resource model and associated resource estimate. The respective Domains for each of the estimated metals (copper, gold and molybdenum) were tagged prior to exploratory data analysis. The back-tagged drill hole file was then restricted to only the data which occurred within the 2009 pit-shell for statistical analysis as outlined below.

The mean grade of most domains changed little with compositing and application of respective caps. The capping application preceded the compositing of the data. Declustering of the data had negligible effect on the mean grade, indicating the data are well declustered to begin with. The effect of declustering is discussed further in the text.

Standard deviation, variance and coefficient of variance all demonstrate that the Domains have a relatively small spread of assay values, and do not have large outlier populations, either in grade or in number.

Table 17.3.1 to Table 17.3.3 outline the descriptive statistics for the drill hole and block model data for the respective domains. Figure 17.3.1 provides representative histograms depicting the statistical characteristics for the raw data in comparison with the composited data. Note the drop in the number of samples available with compositing, combined with a slight decrease in mean and maximum grades as the compositing effectively averages grades and lowers the variance of the sample dataset.

**Table 17.3.1 Descriptive Statistics for Drill Hole and Block Model Data with Respect to Copper Domains in the Pebble Deposit**

FIELD	TYPE	ZONE	NRECORDS	NSAMPLES	MINIMUM	MAXIMUM	MEAN	VARIANCE	STANDDEV	C.V.	SKEWNESS	KURTOSIS
Cu %	Raw	1	66307	848	0.0010	0.2300	0.0467	0.0015	0.0383	0.8206	1.2375	1.7755
Cu %	Declust	1	60245	701	0.0010	0.2300	0.0453	0.0015	0.0381	0.8406	1.2101	1.6286
Cu %	Comp	1	150	150	0.0010	0.4660	0.0765	0.0061	0.0781	1.0211	2.0451	5.4375
Cu %	Model	1	613475	2466	0.0001	0.2118	0.0689	0.0015	0.0387	0.5613	0.1611	-0.1761
Cu %	Raw	2	66307	3150	0.0050	7.4000	0.4930	0.0988	0.3144	0.6377	5.9429	94.0091
Cu %	Declust	2	60245	2497	0.0050	7.4000	0.4917	0.0991	0.3148	0.6402	6.5344	109.7884
Cu %	Comp	2	559	559	0.0480	1.7720	0.4740	0.0438	0.2092	0.4413	1.1857	3.3452
Cu %	Model	2	613475	4901	0.1407	0.8359	0.4456	0.0162	0.1274	0.2858	0.5060	-0.1747
Cu %	Raw	40	66307	12192	0.0000	1.3300	0.1057	0.0083	0.0912	0.8626	2.5969	15.7457
Cu %	Declust	40	60245	11266	0.0000	1.3300	0.1059	0.0083	0.0913	0.8623	2.6541	16.4751
Cu %	Comp	40	2324	2324	0.0000	0.4920	0.1100	0.0053	0.0728	0.6613	0.8662	1.0233
Cu %	Model	40	613475	295553	0.0069	0.3263	0.1228	0.0026	0.0515	0.4192	-0.0021	-0.6551
Cu %	Raw	41	66307	18774	0.0021	9.2900	0.3059	0.0314	0.1771	0.5791	10.6138	403.6846
Cu %	Declust	41	60245	15826	0.0021	4.5300	0.3041	0.0269	0.1640	0.5392	5.0921	82.1510
Cu %	Comp	41	3458	3458	0.0130	1.4460	0.3075	0.0144	0.1199	0.3899	1.7633	6.9080
Cu %	Model	41	613475	85247	0.0932	0.9644	0.2902	0.0060	0.0774	0.2667	1.6763	5.4251
Cu %	Raw	42	66307	13403	0.0005	4.9100	0.5389	0.1194	0.3455	0.6412	1.8201	6.8909
Cu %	Declust	42	60245	12683	0.0005	4.9100	0.5388	0.1171	0.3422	0.6352	1.8151	7.1237
Cu %	Comp	42	2626	2626	0.0010	1.9770	0.5432	0.0881	0.2968	0.5463	1.2095	1.6593
Cu %	Model	42	613475	163647	0.0944	1.7157	0.5160	0.0488	0.2209	0.4281	1.2154	1.5476
Cu %	Raw	43	66307	4526	0.0040	6.3600	0.6626	0.1567	0.3959	0.5975	2.1743	14.3366
Cu %	Declust	43	60245	4310	0.0040	6.3600	0.6646	0.1568	0.3960	0.5958	2.2063	14.8543
Cu %	Comp	43	888	888	0.0580	2.2960	0.6633	0.1127	0.3357	0.5060	1.2114	2.0548
Cu %	Model	43	613475	61661	0.2061	1.9820	0.6085	0.0531	0.2305	0.3787	1.2368	2.2802

**Table 17.3.2 Descriptive Statistics for Drill Hole and Block Model Data with Respect to Gold Domains in the Pebble Deposit**

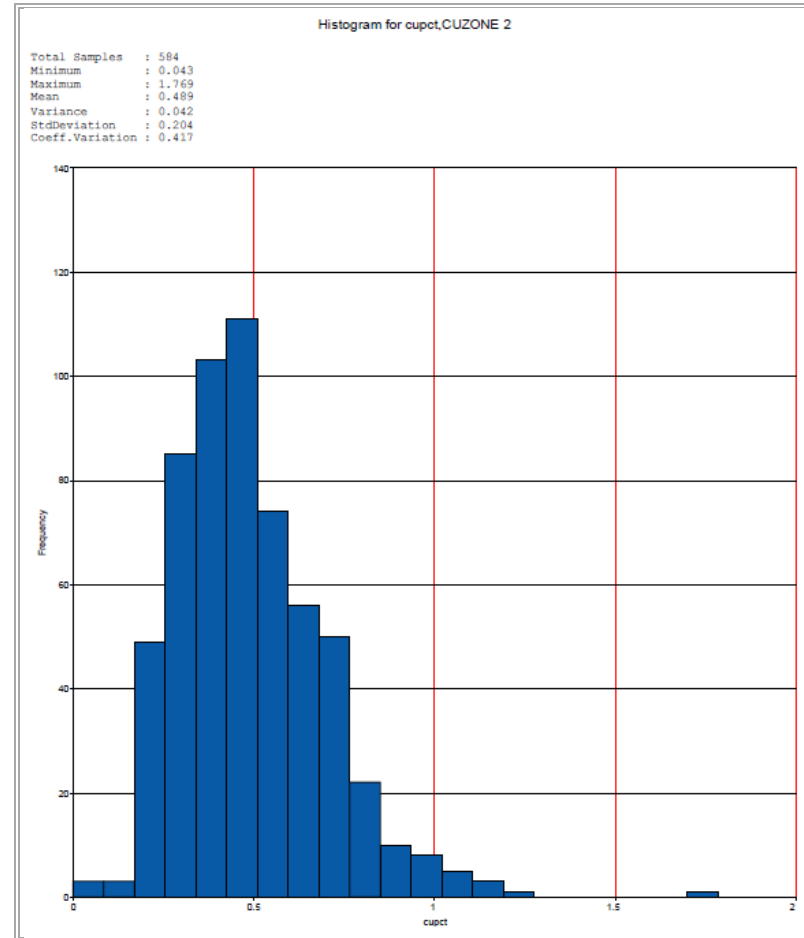
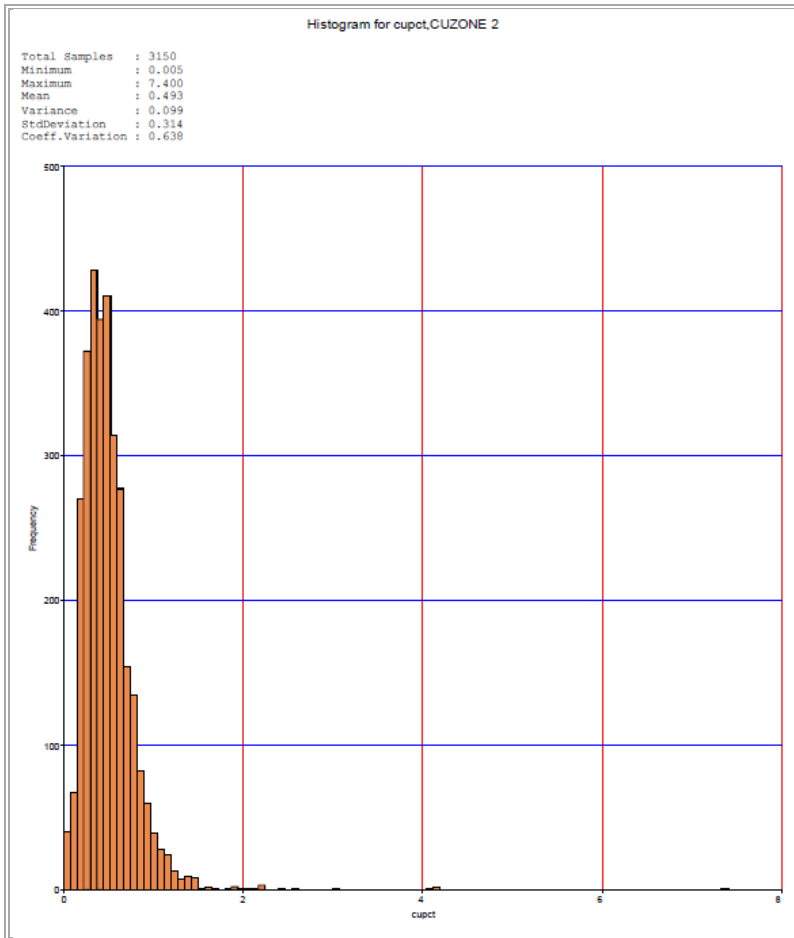
FIELD	TYPE	ZONE	NRECORDS	NSAMPLES	MINIMUM	MAXIMUM	MEAN	VARIANCE	STANDDEV	C.V.	SKEWNESS	KURTOSIS
Au g/t	Raw	40	66307	13276	0.0005	8.0900	0.1415	0.0373	0.1930	1.3646	14.0065	391.9433
Au g/t	Declust	40	60245	12196	0.0005	8.0900	0.1405	0.0390	0.1975	1.4059	14.1574	388.9820
Au g/t	Comp	40	2500	2500	0.0060	1.5500	0.1460	0.0127	0.1128	0.7724	3.4889	25.8887
Au g/t	Model	40	613475	244240	0.0257	0.7401	0.1561	0.0033	0.0577	0.3694	1.4880	5.7051
Au g/t	Raw	41	66307	21693	0.0005	334.8000	0.4040	5.3541	2.3139	5.7280	139.2966	20,105.8655
Au g/t	Declust	41	60245	17987	0.0005	334.8000	0.4016	6.3959	2.5290	6.2972	128.6368	16,991.7946
Au g/t	Comp	41	3964	3964	0.0280	2.9530	0.3827	0.0506	0.2250	0.5879	3.6499	23.5253
Au g/t	Model	41	613475	110526	0.1152	1.8155	0.3700	0.0154	0.1240	0.3351	1.5929	5.6304
Au g/t	Raw	42	66307	13836	0.0020	67.8000	0.3824	0.9623	0.9810	2.5651	48.0458	3,062.4644
Au g/t	Declust	42	60245	13107	0.0020	67.8000	0.3838	1.0032	1.0016	2.6098	47.5714	2,973.4034
Au g/t	Comp	42	2725	2725	0.0030	4.3620	0.3729	0.1023	0.3199	0.8578	3.6017	26.2900
Au g/t	Model	42	613475	196900	0.0376	1.9224	0.3514	0.0325	0.1803	0.5131	1.1254	2.6015
Au g/t	Raw	43	66307	4198	0.0050	11.9000	0.5220	0.4466	0.6682	1.2801	6.2416	68.1743
Au g/t	Declust	43	60245	4013	0.0050	11.9000	0.5207	0.4550	0.6745	1.2954	6.3112	68.6557
Au g/t	Comp	43	820	820	0.0590	3.2840	0.5143	0.1843	0.4292	0.8347	2.0079	5.1682
Au g/t	Model	43	613475	61809	0.0674	2.0616	0.4637	0.0676	0.2601	0.5609	1.6678	3.6712



**Table 17.3.3 Descriptive Statistics for Drill Hole and Block Model Data with Respect to Molybdenum Domains in the Pebble Deposit**

FIELD	TYPE	ZONE	NRECORDS	NSAMPLES	MINIMUM	MAXIMUM	MEAN	VARIANCE	STANDDEV	C.V.	SKEWNESS	KURTOSIS
Mo ppm	Raw	40	66307	8829	0.5000	3,600.0000	31.5651	3,528.7045	59.4029	1.8819	27.8988	1,518.9137
Mo ppm	Declust	40	60245	7967	0.5000	3,600.0000	31.1464	3,483.6594	59.0225	1.8950	30.6835	1,719.9397
Mo ppm	Comp	40	1656	1656	0.5000	188.2000	31.0335	833.0005	28.8617	0.9300	1.4148	2.4051
Mo ppm	Model	40	613475	131735	0.7117	137.9312	31.2441	283.3102	16.8318	0.5387	0.6317	0.4061
Mo ppm	Raw	41	66307	22352	0.5000	26,290.0000	184.9056	106,763.8648	326.7474	1.7671	48.8470	3,698.6424
Mo ppm	Declust	41	60245	18698	0.5000	26,290.0000	182.8913	76,270.9406	276.1719	1.5100	48.1677	4,301.1686
Mo ppm	Comp	41	4091	4091	7.3000	1,465.2170	178.4268	14,322.1089	119.6750	0.6707	3.0027	14.8588
Mo ppm	Model	41	613475	141972	43.9408	772.1703	164.8854	4,311.5809	65.6626	0.3982	1.4107	3.1761
Mo ppm	Raw	42	66307	15579	4.0400	12,300.0000	300.6072	113,718.3713	337.2215	1.1218	11.7703	313.7470
Mo ppm	Declust	42	60245	14809	4.0400	12,300.0000	301.8059	116,117.9102	340.7608	1.1291	11.9152	316.0491
Mo ppm	Comp	42	3062	3062	5.0000	1,602.4000	296.9002	32,070.6602	179.0828	0.6032	1.3524	3.0234
Mo ppm	Model	42	613475	253772	48.1285	794.9545	288.3275	14,571.9035	120.7141	0.4187	0.3891	-0.2716
Mo ppm	Raw	43	66307	5823	5.0000	8,420.0000	326.9706	115,205.1369	339.4188	1.0381	8.0090	131.8538
Mo ppm	Declust	43	60245	5575	5.0000	8,420.0000	327.3704	117,916.0180	343.3890	1.0489	8.0478	131.3295
Mo ppm	Comp	43	1147	1147	18.9500	1,286.8000	321.6653	33,895.2522	184.1066	0.5724	1.4278	2.9514
Mo ppm	Model	43	613475	85269	59.2637	789.0280	330.2710	12,363.8914	111.1930	0.3367	0.6136	0.0558
Mo ppm	Raw	45	66307	178	5.0000	130.0000	32.9213	623.7691	24.9754	0.7586	1.3163	1.9833
Mo ppm	Declust	45	60245	163	5.0000	130.0000	33.4049	630.5845	25.1114	0.7517	1.3213	2.0126
Mo ppm	Comp	45	42	42	1.5640	226.4000	30.1363	1,277.6688	35.7445	1.1861	3.9375	18.8377
Mo ppm	Model	45	613475	727	30.0000	30.0000	30.0000	-	-	-	-	-

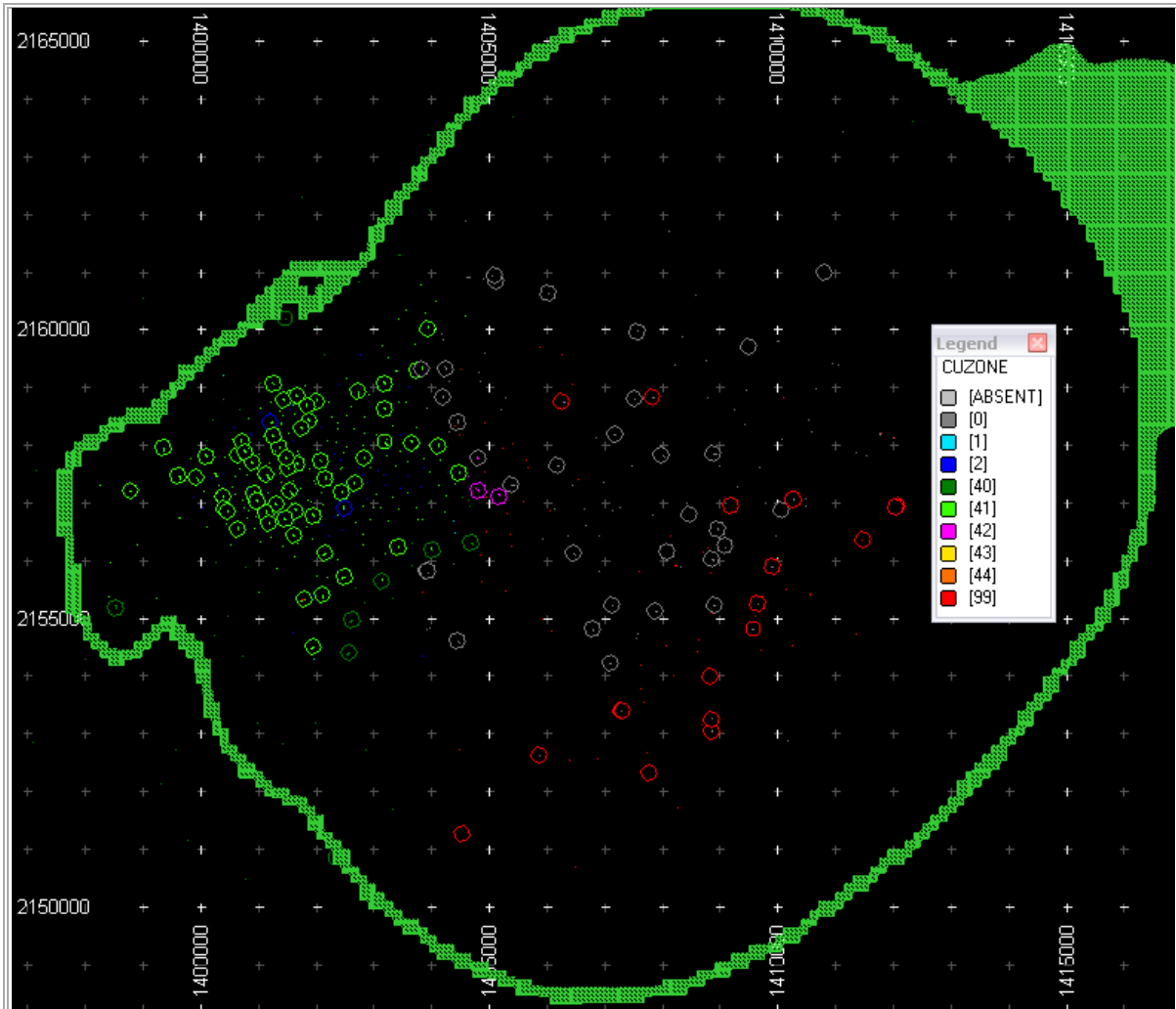
Figure 17.3.1 Histograms for Copper (CUZONE 2) – Raw Data and Compositied Data



**17.3.1 DATA CLUSTERING**

The drill hole data for the entire Pebble deposit shows considerable clustering with respect to vintage of drilling and depth of mineralization. In general, the Pebble West mineralization, with relatively shallow mineralization, records more tightly-spaced drill hole collar positions than later-drilled and deeper Pebble East mineralization (Figure 17.3.2).

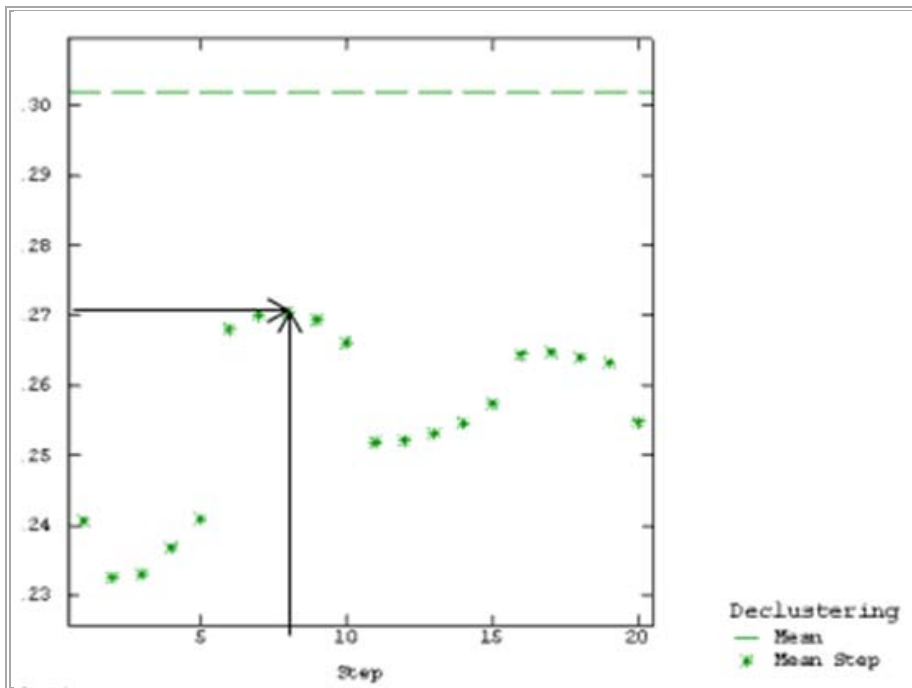
**Figure 17.3.2 Plan View of Pebble Deposit at 850 ft Elevation**



Note: Green wireframe represents pit outline. North is to top and grid in Alaskan reference. Grid points are 1,000 ft apart.

An optimal declustering grid size, which could accommodate the tighter-spaced drilling to the west of the deposit, and the more distally-spaced drilling to the east, was determined using Isatis™ geostatistical software. Optimal mean grades were recorded with an 86 ft square grid (Figure 17.3.3).

**Figure 17.3.3 Results of Declustering Grid Optimization Study**



Note: demonstrates the optimal grid size to be 86 ft<sup>2</sup> (step size; x-axis) to maximize mean grade (0.272% Cu; y-axis).

Thus a declustered dataset was generated using a grid size of 86 ft (X), 86 ft (Y) and 10 ft (Z), and incorporated in comparative statistics. Inspection of these statistics between the raw data and the declustered data show the difference between the declustered mean data (by domain) and the raw data varies from -0.36% to +0.76% with an average of +0.08%. This suggests that declustering can overall marginally increase the mean grade.

### 17.3.2 ASSAYS

Assays are separated into their respective metals and their respective domains. Assay statistics are tabulated below.

### 17.3.3 OUTLIER MANAGEMENT AND CAPPING STRATEGY

When dealing with skewed populations, as well as outliers to the distribution, it is common practice in the industry to restrict the influence of high assays through “top-cutting” or “capping”. In 2009, the Pebble Partnership carried out an analysis of the sample distributions and capped the database at the same levels as employed in the previous estimate. Top cuts are shown in Table 17.3.4.

**Table 17.3.4 Top Cuts**

	Domain	Top Cut	Mean (Raw)	Mean (Comp)	# of TC samples	# of Samples
Cu %	1	0.25	0.047	0.047	0	848
	2	2.2	0.493	0.489	7	3,150
	40	0.8	0.106	0.105	12	12,192
	41	2	0.306	0.305	8	18,774
	42	2.4	0.539	0.538	12	13,403
	43	2.4	0.663	0.661	17	4,526
Au g/t	40	2.8	0.142	0.141	29	13,276
	41	7	0.404	0.387	10	21,693
	42	7.7	0.382	0.37	12	13,836
	43	4.3	0.522	0.512	14	4,198
Mo ppm	40	300	32	31	31	8,829
	41	2100	185	181	42	22,352
	42	2800	301	297	22	15,579
	43	2800	327	323	16	5,823
	45	n/a	32.82	32.82	0	178

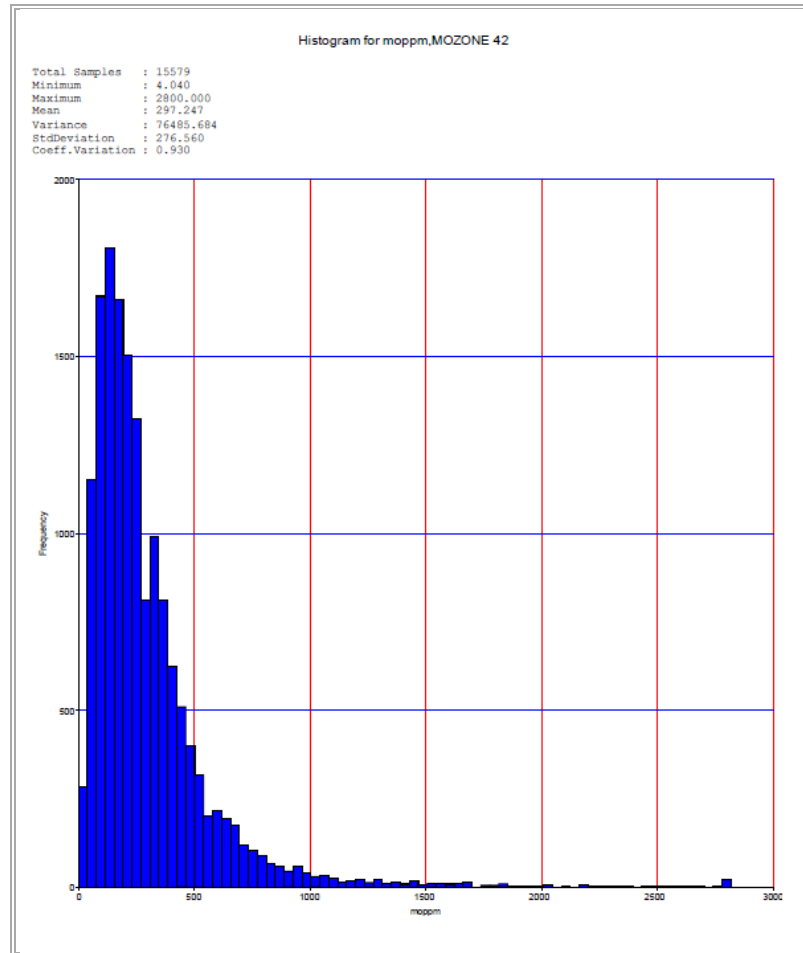
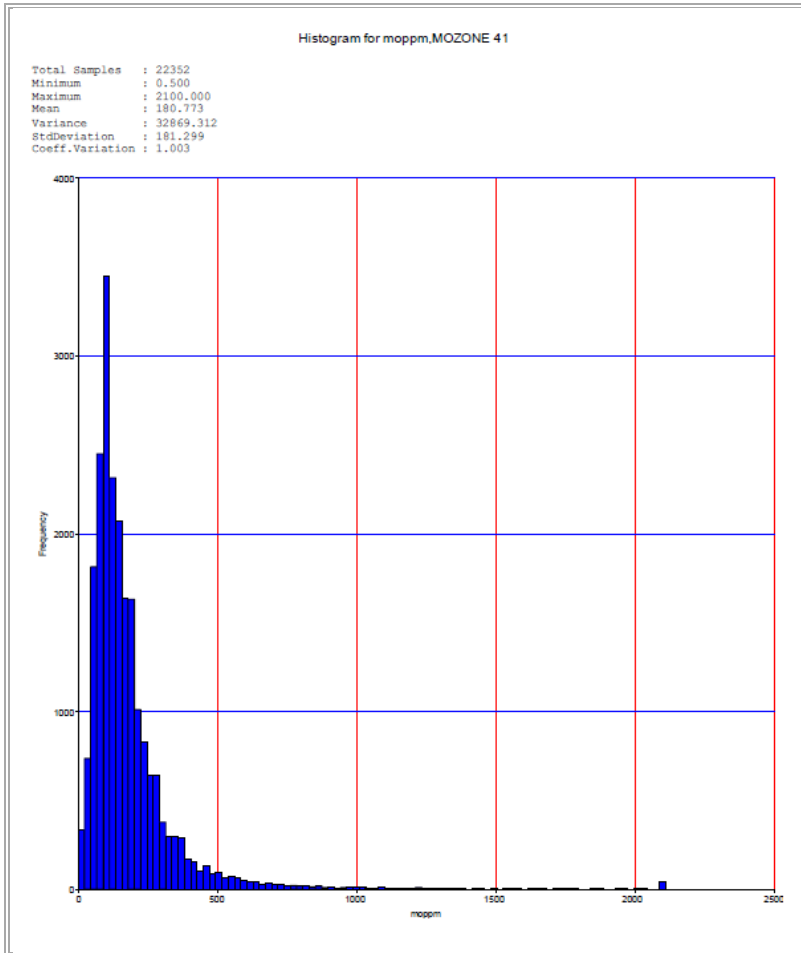
Capping limits were chosen as a function of the continuity – discontinuity of the high-grade “tail” of the respective Domain histograms. Capping was then applied to the raw data. Examples of resultant histograms (domains MOZONE 41 and MOZONE 42) of the capped data are depicted in Figure 17.3.4. Note the outlier population to the far right of the histograms is reduced to a single population corresponding to the top-cut or cap value.

The capping levels tend to be close to the 99.8th to 99.9th percentile, which is broadly similar to past practice for Pebble East. The Pebble West estimate, because it was previously done using MIK, did not employ top cuts. However in 2005, a validation model generated using Inverse Distance Cubed (ID<sub>3</sub>), and top cuts at 6.9 g/t of gold, 2.0% copper, and 2,000 ppm molybdenum yielded very similar results to the MIK model. While direct comparison is difficult owing to the changes in domains, those caps were marginally lower than the ones used in the 2008 estimate.

The top cuts applied to copper have had minimal effect on the sample means. The caps applied to domains 40 and 42, for example, have not changed the mean at all. For gold, the capping was more aggressive and has had a measurable effect on the means for all domains except 40. The molybdenum caps are also somewhat high, although their impact is more measurable than that for copper.

Domain 45 was not capped, although it is noted that this domain is very low grade and does not significantly contribute to the metal content of the resource.

Figure 17.3.4 Histograms of Raw Data of Molybdenum Domains with Capped Values



#### 17.3.4 COMPOSITES

Commonly, drill hole assays are based on 10 ft sample lengths. The 50 ft sample composite length is designed to complement the 50 ft thick model block size. Raw, un-composited sample lengths generally honoured lithological boundaries. These ~10 ft sample lengths have been combined into 50 ft composite samples. Composite lengths ignored domain boundaries. Composite lengths commenced at the base of overburden or the Tertiary sequence. End-of-hole samples (if less than 20 ft in length) have been ignored.

### 17.4 BULK DENSITY

---

Site personnel have routinely collected bulk density measurements from drill core specimens. At approximate 100 ft intervals, disks have been cut with a diamond saw, weighed dry and suspended in water. The bulk density is estimated from the ratio of the weight in air to the difference between the weight in air and weight in water (i.e. the ratio of the dry weight to the weight of water displaced by the specimen). The core specimens are not sealed before measurement and this can lead to overestimation of density in area of high porosity.

Scott Wilson RPA noted in their 2008 mineral resource study that porosity does not appear to be a concern in most of the deposit, especially in the hypogene zone. However, it is noted that some densities were measured without allowing for sufficient time for drying and cooling samples prior to weighing. The very slight error introduced into the data was compensated by multiplying the entire dataset by 0.99 (99%).

At the time of compilation of the 2008 resource estimate, a total of 8,754 bulk density measurements had been collected of which 5,854 were pertinent to the resource estimate. Density was interpolated into the block model as three broad domains (1, 2 and 3) using ordinary kriging. The three domains correspond to stoichiometrically determined sulphide concentrations in fresh rock. Thus Domain 3 has relatively the highest proportion of sulphides, and Domain 1 has the lowest (for ore-bearing rocks).

In Figure 17.4.1, the blue represents density Domain 1, magenta represents density Domain 2, and green dashes represent density Domain 3. The dark blue horizontal line is the topographic wireframe, the green line is the pit shell wireframe, and the tan wireframe to the east is the Tertiary unconformity. A clipping distance of 200 ft was used.

Figure 17.4.1 West-East Section through the Deposit at 2157000 ft North Showing Density Data as 10-ft Long Sections

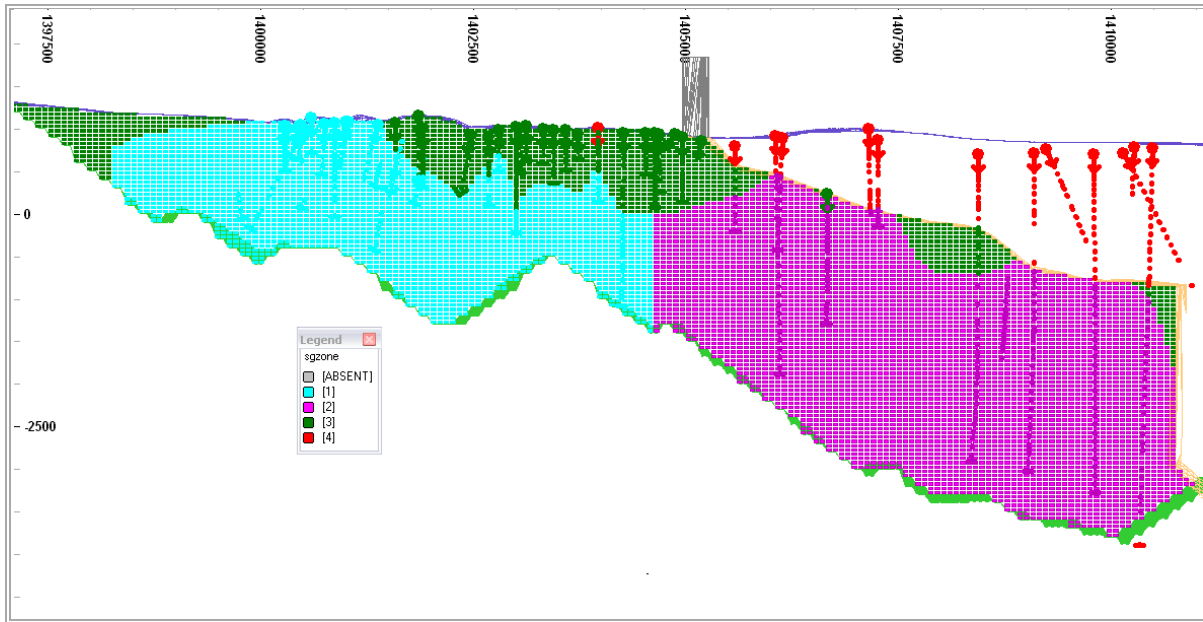
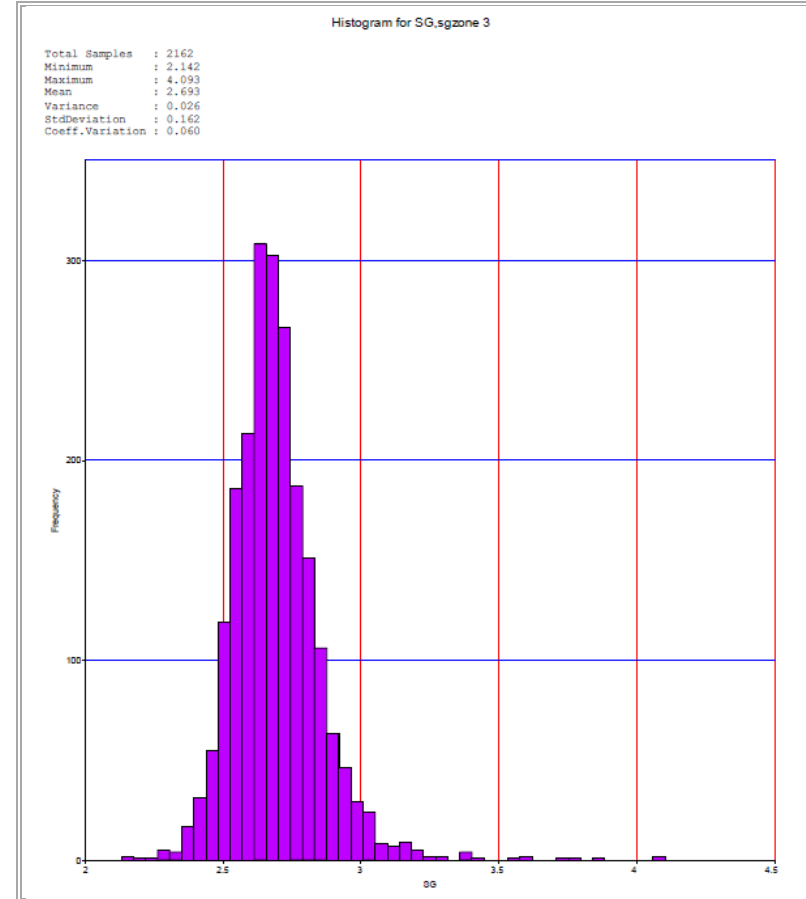
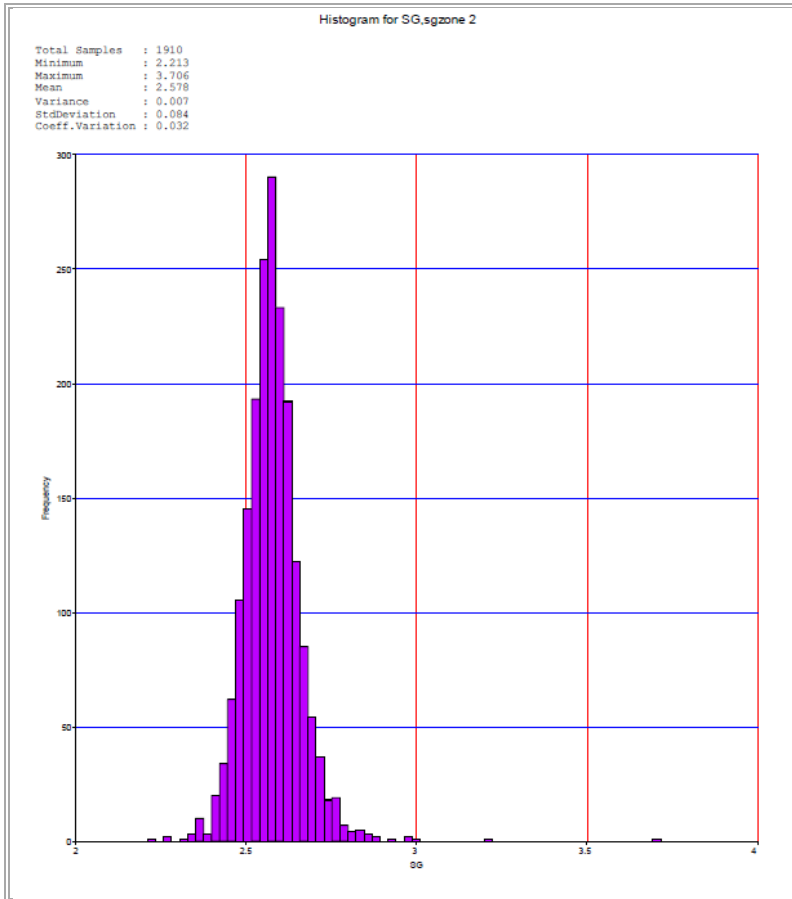


Table 17.4.1 Statistics for Density (Specific Gravity) for Domains (SGZONE) 1, 2, and 3

Domain Type	SGZONE1			SGZONE2			SGZONE3		
	Samp	Mod	Mod (Adj)	Samp	Mod	Mod (Adj)	Samp	Mod	Mod (Adj)
Record	7984	804126	804126	7984	804126	804126	7984	804126	804126
Samples	1156	124277	124277	1910	307844	307844	2162	371786	371786
Minimum	1.999	2.346	2.322	2.213	2.418	2.394	2.142	2.450	2.426
Maximum	4.428	2.769	2.741	3.706	2.817	2.789	4.093	3.029	2.999
Mean	2.584	2.600	2.574	2.578	2.579	2.553	2.693	2.729	2.702
Variance	0.020	0.003	0.003	0.007	0.002	0.002	0.026	0.010	0.009
Standdev	0.140	0.055	0.054	0.084	0.042	0.041	0.162	0.098	0.097
Skewness	2.610	-0.415	-0.415	1.801	0.383	0.383	1.705	0.072	0.072
Kurtosis	29.770	-0.221	-0.221	19.877	0.562	0.562	9.559	-0.533	-0.533



**Figure 17.4.2 Representative Histograms of Density Data for SGZONE 2 and SGZONE 3**



## 17.5 GEOLOGICAL INTERPRETATION

---

The Pebble deposit has been divided into domains of like statistical characteristics which have been used to properly select and constrain interpolation. Different domains have been constructed for each component estimated into the block model. For some components, such as the economic elements, there are as many as nine domains; while for some others, such as zinc and lead, there is only one.

Two of the new domains are post-ore features that do not contain significant mineralization. These are the overburden and the late Cretaceous to Tertiary cover that overlay the eastern part of the deposit.

Other major features or structures for which models have been constructed include the unconformity at the base of the post-ore Tertiary units in the east (K-T), the ZG Fault, the ZE Fault, and the 6348 fault block. The ZG Fault is a major north/northeast-south/southwest striking structure that downthrows the mineralization to the east. A wireframe of a strand of this fault, the ZG<sub>1</sub>, has been constructed from 21 drill hole intercepts and it effectively bounds the deposit to the east. The ZE Fault is a steep east/west-striking fault, which traverses the east zone, down-dropping the south side by as much as 900 ft.

The morphology of the deposit varies going from west to east, due to the orientation of the host rock lithology and structures. In the east, the deposit resembles a roughly cylindrical shape, similar in some respects to the intrusion that forms the principal source of the mineralizing fluids. Towards the west, the mineralization occurs in a more tabular shape, gradually flattening and following the dip of the package of sills and sedimentary layers.

## 17.6 SPATIAL ANALYSIS – VARIOGRAPHY

---

Variography has been conducted using Supervisor™ software v. 7.10.16. Samples used for variography are a function of geological interpretation (domaining), assaying, data capping and compositing. For the Pebble deposit, separate variograms were completed for each of the metal and specific gravity domains. Supervisor™ software has been used to generate variography. Composited drill hole data was exported as a text file (.csv file) from Vulcan™ and imported directly into Supervisor™. Downhole variograms, using a lag distance equal to the composite length, were created for each of the separate domains. From the downhole variograms, the variogram structures were derived and applied to subsequent spatial variography for each respective domain. As the average distance between drill holes is approximately 200-300 ft, a 200 ft lag distance was determined to be the optimum distance for modelling spatial continuity. The number of lags varied, but usually 10 lags to cover 3,000 ft sufficed. All variograms utilized 400 ft bandwidths, 10° directional increments and 30° tolerance to optimize orientations.

Experimental variography was subsequently used to interpret best-fit modeled variography. Similarly, calculations were weighted by pairs.

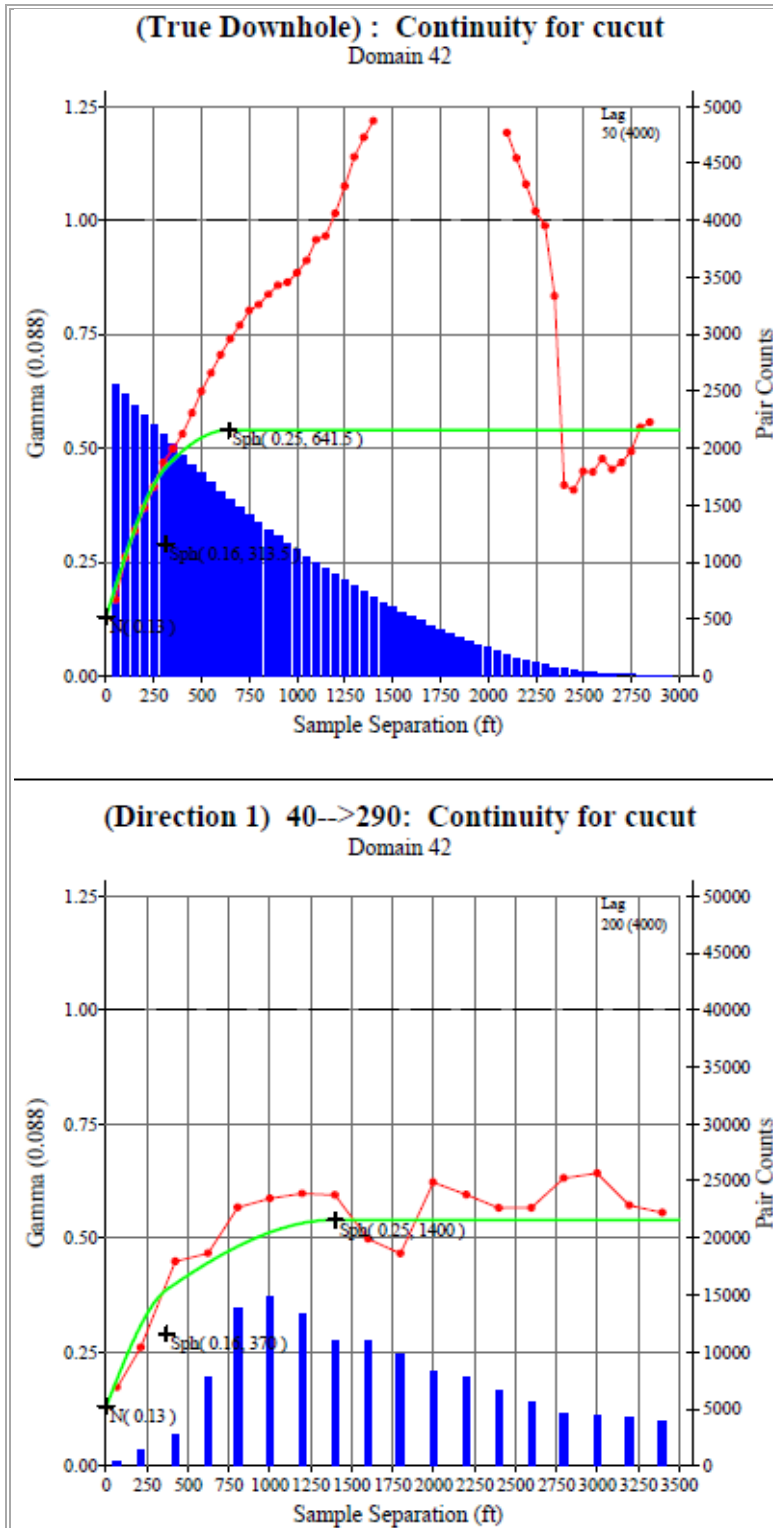
Orientations generated in Supervisor™ were exported to customized Vulcan™ rotation schematics, involving strike of the longest axis (X) by clockwise rotation around the Z-axis, plunge of the second-major axis (Y) by clockwise rotation around the X axis, and dip of the minor axis (Z) by clockwise rotation around the Y axis. These orientations are later presented in Table 17.7.1. The Bearing, Plunge, and Dip values are angles, in degrees, that specify the orientation of the search ellipsoid and orientation of variogram structures. The bearing of the orebody, project the orebody axis straight up onto the surface plane and call this line the bearing line. The bearing is the angle clockwise from north to the bearing line. Plunge is the angle between the horizontal plane and the orebody axis. Note that the plunge should be negative for a downward pointing orebody. The dip is the angle of rotation to bring the plane into the horizontal plane. Looking north, if the plane must be rotated clockwise around the north-south axis, then the dip is positive.

An example of the experimental and modelled variography is presented in Figure 17.6.1 and Figure 17.6.2 (Copper Domain 42).

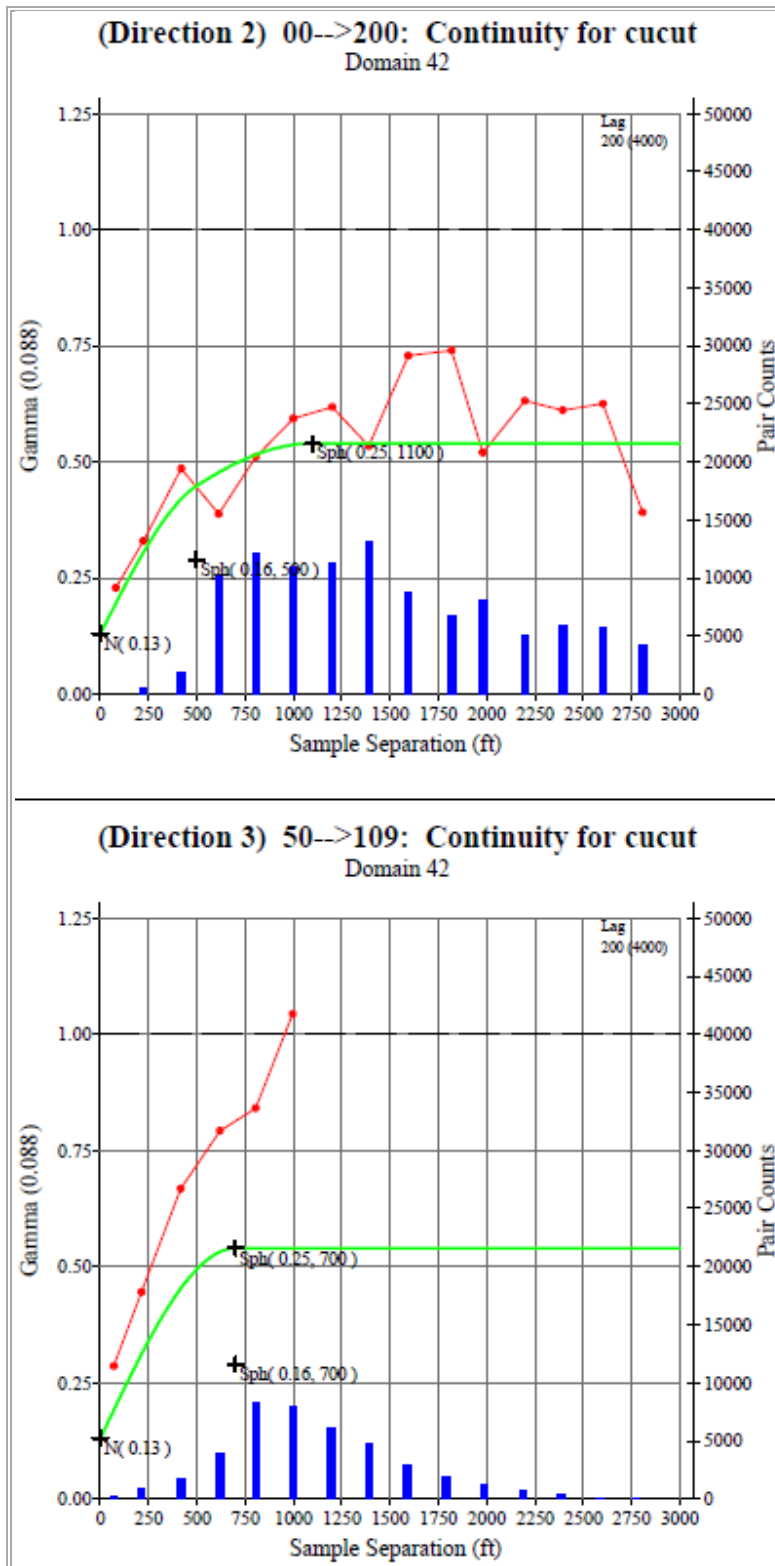
Modelled variography results were recorded as an enclosed parameter file (Kriging Plan), and as plot files for visual reference.

Eight of 14 variograms were generated with modelled sills (total modelled variance) up to 55% of the total experimental sill (total sample variance). This is based on geological interpretation of maximum mineralization continuity. However, the February 2010 resource report quoted “over-smoothing” in Domain 41. This was subsequently accommodated by changes in the sample search parameter definition file. Wardrop suggests that over-smoothing may have been in response to low modelled sills, and that over-smoothing may also be problematic in other domains where the modelled sill is not equal to the experimental sill.

Figure 17.6.1 Downhole and Major Axis Experimental and Modelled Variography for Copper Domain 42



**Figure 17.6.2 Experimental and Modelled Variography for Semi-major and Minor Axes for Copper Domain 42**



1056140100-REP-R0001-00

## 17.7 RESOURCE BLOCK MODEL

---

As with the earlier models, the parent block size was set at 75 ft x 75 ft x 50 ft, with no sub-blocking and no rotation. The size was originally determined as the best fit for the original drilling grid in the western part of the deposit, and the model was subsequently expanded eastward as additional drilling was completed. The model axes are aligned with the Alaska State Plane coordinate grid (Zone 5 NAD 85), and the model uses these coordinates. Block model geometry is summarized in Table 17.7.1.

**Table 17.7.1 Block Model Geometry**

	X	Y	Z
Origin (ft)	1,396,000	2,153,000	-2,000
Block Size (ft)	75	75	50
Block Count	230	160	150
Block Extent (ft)	17,250	12,000	7,500

## 17.8 INTERPOLATION PLAN

---

Ordinary kriging (OK) has been employed as the grade interpolation methodology in much the same manner as implemented as the 2008 and 2009 Pebble mineral estimates.

The grade interpolation was carried out in three passes. In the first pass, the search was constrained to 95% of the range of the variogram model for that particular domain. The axes of the search ellipsoids were oriented parallel to the variogram model. In the second pass, the search was extended to 1.5 times the range of the first pass. For the third, and final, pass, the range was extended to 3 times the 1st pass range.

For the principal metals (copper, gold and molybdenum), the first two passes were limited to a minimum of eight composites with a maximum of three composites from any one drill hole. In the third pass, the minimum composite constraint was set to five. The maximum number of composites was limited to 24 for all but the 41 domain, where it was set to 12, in order to minimize smoothing.

The searches were configured to allow composites to be extrapolated across some domain boundaries (termed “soft” boundaries) but not others (“hard” boundaries). The application of hard and soft boundaries is summarized in Table 17.8.1.

**Table 17.8.1 Domain Boundaries – “Hard” vs. “Soft” Divisions**

Zone Estimated	Composites Allowed
cuzone 41	cuzone 41, 42 & 43
cuzone 42	cuzone 42 & 41
cuzone 43	cuzone 43 & 41
auzone 41	auzone 41, 42 & 43
auzone 42	auzone 42 & 41
auzone 43	auzone 42 & 41
mozone 41	mozone 41, 42 & 43
mozone 42	mozone 43 & 41
mozone 43	mozone 43 & 41
sgzone 1	sgzone 1 & 2
sgzone 2	sgzone 1 & 2

**Table 17.8.2 Search Parameters Adopted for Estimation**

Domain Metal/Zone/Pass	Axis Rotation			Axis Distance			Sample Number	
	Z	Y	X	Major	Semi	Minor	Min	Max
au40	0	-0.5	0	510	510	260	8	24
au40b	0	-0.5	0	765	765	390	8	24
au40c	0	-0.5	0	1530	1530	780	5	24
au41	70	0	-0.5	800	600	560	8	12
au41b	70	0	-0.5	1200	900	840	8	12
au41c	70	0	-0.5	2400	1800	1680	5	12
au42	290	20	0	825	1110	600	8	24
au42b	290	20	0	1237	1665	900	8	24
au42c	290	20	0	2475	3330	1800	5	24
au43	79	-17	-10	715	460	350	8	24
au43b	79	-17	-10	1073	690	525	8	24
au43c	79	-17	-10	2145	1380	1050	5	24
au44	310	58	-17	1180	1030	400	8	24
cu1	40	0	0	550	530	270	8	24
cu1b	40	0	0	825	795	405	8	24
cu1c	40	0	0	1650	1590	810	5	24
cu2	30	0	-0.5	675	390	400	8	24
cu2b	30	0	-0.5	1012	585	600	8	24
cu2c	30	0	-0.5	2025	1170	1200	5	24
cu40	72	-30	-28	1100	1020	425	8	24
cu40b	72	-30	-28	1650	1530	640	8	24
cu40c	72	-30	-28	3300	3060	1275	5	24
cu41	53	-20	-79	2900	950	950	8	12
cu41b	53	-20	-79	4350	1425	1425	8	12

Table continues...

...Table 17.8.2 (cont'd)

Domain Metal/Zone/Pass	Axis Rotation			Axis Distance			Sample Number	
	Z	Y	X	Major	Semi	Minor	Min	Max
cu41c	53	-20	-79	8700	2850	2850	5	12
cu42	290	40	-0.5	1023	830	540	8	24
cu42b	290	40	-0.5	1534	1245	810	8	24
cu42c	290	40	-0.5	3069	2490	1620	5	24
cu43	310	58	-17	1180	1030	400	8	24
cu43b	310	58	-17	1770	1545	600	8	24
cu43c	310	58	-17	3540	3090	1200	5	24
cu44	310	58	-17	1180	1030	400	8	24
mo40	160	0	90	720	155	350	8	24
mo40b	160	0	90	1080	233	525	8	24
mo40c	160	0	90	2160	465	1050	5	24
mo41	180	0	-90	1200	800	1200	8	12
mo41b	180	0	-90	1800	1200	1800	8	12
mo41c	180	0	-90	3600	2400	3600	5	12
mo42	130	0.5	-90	900	890	900	8	24
mo42b	130	0.5	-90	1350	1335	1350	8	24
mo42c	130	0.5	-90	2700	2670	2700	5	24
mo43	143	-68	-26	1230	1430	710	8	24
mo43b	143	-68	-26	1845	2145	1065	8	24
mo43c	143	-68	-26	3690	4290	2130	5	24
mo44	310	58	-17	1180	1030	400	8	24
sg0	30	0	0	1000	1000	600	8	24
sg0b	30	0	0	1500	1500	900	8	24
sg0c	30	0	0	5000	5000	3000	5	24
sg1	88	6	40	450	350	325	8	24
sg1b	88	6	40	675	525	488	8	24

## 17.9 MINERAL RESOURCE CLASSIFICATION

Ongoing geostatistical examination of the spatial characteristics of the Pebble deposit by Northern Dynasty geologists indicate that a classification of Measured can be assigned to blocks drilled with a spacing of 200 ft to 250 ft. This is the drill hole spacing that was applied to part of the western zone. Similar assessments by Northern Dynasty geologists suggest that an Indicated classification can be applied for resources drilled at 600 ft spacing. Thus blocks were assigned provisional mineral resource classifications based largely on average distance to drill holes.

The rules for this assignment were as follows:

- Blocks wherein the average distance to the nearest three holes was less than or equal to 250 ft were provisionally classed as Measured.



- Blocks wherein the average distance to the nearest three holes was less than or equal to 500 ft were provisionally classed as Indicated.
- Blocks within 600 ft laterally and 300 ft vertically from a drill hole were provisionally classed as Inferred.

The classification was then manually adjusted to eliminate isolated blocks of one classification surrounded by blocks of another. Wireframe models were constructed which enclosed the main volumes of each classification and these wireframes were used to assign the class codes within them.

## 17.10 MINERAL RESOURCE TABULATION

---

NI 43-101 relies on the CIM Standards on Mineral Resources and Reserves Definitions and Guidelines for the definition of Mineral Resources. Among other things, for a mineralized body to be considered Mineral Resources, it must be demonstrated that under reasonable technical assumptions, it must have “reasonable prospects for economic extraction”. One of the principal conditions for “reasonable prospects for economic extraction” is met by application of a cut-off grade. In the absence of operating experience or of a detailed feasibility study, it is generally accepted practice to use a cut-off grade from mines with similar characteristics (i.e. size, deposit type, grades). This has, up to now, been the practice at Pebble.

A copper equivalent (CuEQ) grade is calculated from the copper, gold and molybdenum based on the ratio of the respective metal prices. Up to 2008, the metal prices used for this calculation were US\$1.00 per pound of copper, US\$600 per ounce of gold and US\$6.00 per pound of molybdenum. For the 2008 estimate, the metal prices used were US\$1.80 per pound of copper, US\$800 per ounce of gold, and US\$10.00 per pound of molybdenum. For the current estimate, the metal prices has been adjusted to US\$1.85 per pound of copper, US\$902 per ounce of gold, and US\$12.50 per pound of molybdenum.

As in the 2008 resource estimate, the CuEQ calculation included metallurgical recovery factors, using data available to 2009. For the Pebble West zone, the recoveries used are 85% for copper, 69.6% for gold, and 77.8% for molybdenum, while for the Pebble East zone; the recoveries are 89.3% for copper, 76.8% for gold, and 83.74% for molybdenum. The generalized equation for CuEQ is as follows:

$$\text{CuEQ} = \text{Cu} + ((\text{Au} * (\text{RAu} / \text{RCu}) * (\text{PAu} / \text{PCu})) + ((\text{Mo} * \text{RMo} / \text{RCu}) * (\text{PMo} / \text{PCu}))$$

Where:

- CuEQ = copper equivalent grade
- Cu = copper grade
- Au = gold grade
- Mo = molybdenum grade
- RCu = copper recovery
- RAu = gold recovery
- RMo = molybdenum recovery

- PCu = copper price
- PAu = gold price
- PMo = molybdenum price.

A rigorous test of the potential for economic extraction was applied to the mineralization in the form of a pit optimization study. The study used metal prices, similar to recent prices. Prices used were US\$2.50/lb for copper, US\$900/oz for gold and US\$25/lb for molybdenum. The copper and molybdenum prices are the three-year moving average, and the gold price is the higher end of a range of analysts' forecasts. The pit shell captured approximately 90% of the mineralization at Pebble; thus Mineral Resources have been expressed as material interior to the resource pit at a grade greater than 0.3% CuEQ.

**Table 17.10.1 November 2010 Mineral Resource Estimate\***

Cut-off (% CuEQ)	CuEQ (%)	Mt	Cu (%)	Au (g/t)	Mo (ppm)	Cu (Blb)	Au (Moz)	Mo (Blb)
<b>Measured</b>								
0.30	0.65	527	0.33	0.35	178	3.8	5.9	0.21
0.40	0.66	508	0.34	0.36	180	3.8	5.9	0.20
0.60	0.77	277	0.40	0.42	203	2.4	3.7	0.12
1.00	1.16	27	0.62	0.62	301	0.4	0.5	0.02
<b>Indicated</b>								
0.30	0.80	5,414	0.43	0.35	257	51.3	60.9	3.07
0.40	0.85	4,891	0.46	0.36	268	49.6	56.6	2.89
0.60	1.00	3,391	0.56	0.41	301	41.9	44.7	2.25
1.00	1.30	1,422	0.77	0.51	342	24.1	23.3	1.07
<b>Measured + Indicated</b>								
0.30	0.78	5,942	0.42	0.35	250	55.0	66.9	3.28
0.40	0.83	5,399	0.45	0.36	260	53.6	62.5	3.09
0.60	0.98	3,668	0.55	0.41	293	44.5	48.3	2.37
1.00	1.29	1,449	0.76	0.52	341	24.3	24.2	1.09
<b>Inferred</b>								
0.30	0.53	4,835	0.24	0.26	215	25.6	40.4	2.29
0.40	0.66	2,845	0.32	0.30	259	20.1	27.4	1.62
0.60	0.89	1,322	0.48	0.37	289	14.0	15.7	0.84
1.00	1.20	353	0.69	0.45	379	5.4	5.1	0.29

\* this table is subject to the notes on following page.

**Note 1:** Copper equivalent calculations used metal prices of US\$1.85/lb for copper, US\$902/oz for gold and US\$12.50/lb for molybdenum, and metallurgical recoveries of 85% for copper 69.6% for gold, and 77.8% for molybdenum in the Pebble West area and 89.3% for copper, 76.8% for gold, 83.7% for molybdenum in the Pebble East area. Revenue is calculated for each metal based on grades, recoveries, and selected metal prices; accumulated revenues are then divided by the revenue at 1% Cu. Recoveries for gold and molybdenum are normalized to the copper recovery as follows:

$$\text{CuEQ (Pebble West)} = \text{Cu \%} + (\text{Au g/t} \times 69.6\%/85\% \times 29.00/40.79) + (\text{Mo \%} \times 77.8\%/85\% \times 75.58/40.79)$$

$$\text{CuEQ (Pebble East)} = \text{Cu \%} + (\text{Au g/t} \times 76.8\%/89.3\% \times 29.00/40.79) + (\text{Mo \%} \times 83.7\%/89.3\% \times 5.58/40.79)$$

**Note 2:** By prescribed definition, “Mineral Resources” do not have demonstrated economic viability. Measured and Indicated Resources are that part of a mineral resource for which quantity and grade can be estimated with a level of confidence sufficient to allow the application of technical and economic parameters to support mine planning and evaluation of the economic viability of the project. Inferred Mineral Resources are that part of a mineral resource for which quantity and grade can be estimated on the basis of geological evidence and limited sampling and reasonably assumed, but not verified, geological and grade continuity. Inferred Mineral Resources are considered too speculative to allow the application of technical and economic parameters to support mine planning and evaluation of the economic viability of the project. The mineral resources fall within a volume or shell defined by long-term metal price estimates of US\$2.50/lb for copper, US\$900/oz for gold and US\$25/lb for molybdenum.

**Note 3:** For bulk underground mining, cut-offs such as 0.60% CuEQ, are typically used for porphyry deposit bulk underground mining operations at copper porphyry deposits located around the world. A 0.30% CuEQ cut-off is considered to be comparable to that used for porphyry deposit open pit mining operations in the Americas. All mineral resource estimates and cut-offs are subject to a feasibility study.

**Note 4:** CIM definition standards for Mineral Resources and Mineral Reserves were followed for resource (CIM Definition Standards dated November 22, 2005, and adopted by CIM Council on December 11, 2005).

## 17.11 BLOCK MODEL VALIDATION

### 17.11.1 INTRODUCTION

Block model validation of the ordinary kriging (OK) interpolation involves the direct comparison with similar interpolation with the same sample data. These interpolation methods include nearest neighbour (NN - polygonal estimation) and Inverse Distance Squared (ID<sup>2</sup>) block models, which were constructed in Datamine™ (version 3.18.3638). The ordinary kriging model was completed using Vulcan™ software.

Block statistics are used to interrogate global similarities and differences by domain. Visual examination of samples to the OK model is completed to ensure no outstanding misallocation of interpolation. The results of the visual examination are presented within as a series of 1,000 ft-spaced northing sections with a 300 ft clipping distance (±150 ft). Swath plots are used to investigate similarities and difference across identical volume references, as defined by the block size, across the entire deposit. The following sections present the results of the investigation.

For specific gravity (density), the original (not adjusted) data is presented unless otherwise documented.

### 17.11.2 COMPARATIVE BLOCK STATISTICS

Using Datamine™, parallel block interpolations of the metals (copper, gold and molybdenum) and specific gravity have been conducted for comparison against the Vulcan™ OK interpolation. The interpolation methods include NN and a weighted interpolator, ID<sup>2</sup>.

#### BLOCK STATISTICS

Table 17.11.1 to Table 17.11.4 outline the resultant statistics for the different interpolation methods. It is interesting to note that the OK mean is often slightly higher than that of either the NN or ID means.

#### VISUAL EXAMINATION

Figure 17.11.1 to Figure 17.11.12 are representative cross sections showing the block model interpolated grades against respective drill hole data.

**Table 17.11.1 Block Statistics by Domain for Copper**

FIELD	NSAMPLES	CUZONE	MINIMUM	MAXIMUM	MEAN	VARIANCE	STANDDEV	STANDERR	SKEWNESS	KURTOSIS
cupct	2466	1	0.0001	0.2118	0.0689	0.0015	0.0387	0.0008	0.1611	-0.1761
cu_nn	2466	1	0.0010	0.1500	0.0427	0.0010	0.0313	0.0006	0.9193	1.0760
cu_id	2466	1	0.0016	0.1478	0.0435	0.0006	0.0236	0.0005	0.1109	0.5239
cupct	4901	2	0.1407	0.8359	0.4456	0.0162	0.1274	0.0018	0.5060	-0.1747
cu_nn	4901	2	0.0434	1.7694	0.4563	0.0391	0.1977	0.0028	1.2797	4.0500
cu_id	4901	2	0.1016	1.2265	0.4668	0.0167	0.1293	0.0018	0.2770	0.0891
cupct	295553	40	0.0069	0.3263	0.1228	0.0026	0.0515	0.0001	-0.0021	-0.6551
cu_nn	295553	40	0.0005	0.6040	0.1193	0.0061	0.0781	0.0001	1.1269	2.6160
cu_id	295553	40	0.0035	0.5318	0.1192	0.0027	0.0520	0.0001	0.1856	-0.0825
cupct	85247	41	0.0932	0.9644	0.2902	0.0060	0.0774	0.0003	1.6763	5.4251
cu_nn	85247	41	0.0048	1.3670	0.2812	0.0118	0.1084	0.0004	1.5027	5.1497
cu_id	85247	41	0.0743	0.9619	0.2850	0.0056	0.0749	0.0003	1.3725	4.1956
cupct	163647	42	0.0944	1.7157	0.5160	0.0488	0.2209	0.0005	1.2154	1.5476
cu_nn	163647	42	0.0006	1.9774	0.5129	0.0839	0.2897	0.0007	1.3063	1.9832
cu_id	163647	42	0.0417	1.7397	0.5157	0.0520	0.2281	0.0006	1.2162	1.5697
cupct	61661	43	0.2061	1.9820	0.6085	0.0531	0.2305	0.0009	1.2368	2.2802
cu_nn	61661	43	0.0540	2.2956	0.6051	0.0853	0.2920	0.0012	1.4264	3.4237
cu_id	61661	43	0.1472	2.1092	0.6083	0.0468	0.2163	0.0009	1.3018	2.5858

**Notes:**

cupct = copper grade by Ordinary Kriging.

cu\_nn = copper grade by Nearest Neighbour.

cu\_id = copper grade by Inverse Distance squared.

**Table 17.11.2 Block Statistics by Domain for Gold**

FIELD	NSAMPLES	AUZONE	MINIMUM	MAXIMUM	MEAN	VARIANCE	STANDDEV	STANDERR	SKEWNESS	KURTOSIS
augpt	244240	40	0.0257	0.7401	0.1561	0.0033	0.0577	0.0001	1.4880	5.7051
au_nn	244240	40	0.0025	1.4320	0.1482	0.0162	0.1274	0.0003	3.3972	16.7114
au_id	244240	40	0.0088	1.0742	0.1450	0.0057	0.0752	0.0002	2.2158	10.5854
augpt	110526	41	0.1152	1.8155	0.3700	0.0154	0.1240	0.0004	1.5929	5.6304
au_nn	110526	41	0.0581	2.9516	0.3581	0.0564	0.2376	0.0007	3.5298	18.7779
au_id	110526	41	0.0878	1.9649	0.3599	0.0183	0.1353	0.0004	1.5870	5.7100
augpt	196900	42	0.0376	1.9224	0.3514	0.0325	0.1803	0.0004	1.1254	2.6015
au_nn	196900	42	0.0032	4.3608	0.3499	0.0947	0.3077	0.0007	3.6615	29.5751
au_id	196900	42	0.0283	2.7449	0.3510	0.0335	0.1831	0.0004	1.3234	4.9950
augpt	61809	43	0.0674	2.0616	0.4637	0.0676	0.2601	0.0010	1.6678	3.6712
au_nn	61809	43	0.0558	3.2400	0.4486	0.1518	0.3896	0.0016	2.6064	9.6635
au_id	61809	43	0.0592	2.6588	0.4513	0.0760	0.2758	0.0011	1.6770	3.7254

**Notes:**

augpt = gold grade by Ordinary Kriging.

au\_nn = gold grade by Nearest Neighbour.

au\_id = gold grade by Inverse Distance squared.

**Table 17.11.3 Block Statistics by Domain for Molybdenum**

FIELD	NSAMPLES	MOZONE	MINIMUM	MAXIMUM	MEAN	VARIANCE	STANDDEV	STANDERR	SKEWNESS	KURTOSIS
moppm	131735	40	0.7117	137.9312	31.2441	283.3102	16.8318	0.0464	0.6317	0.4061
mo_nn	115843	40	0.5000	194.8315	29.5710	830.4330	28.8172	0.0847	1.4269	1.9540
mo_id	115843	40	0.5000	174.0586	29.4621	512.3100	22.6343	0.0665	0.6909	-0.4409
moppm	141972	41	43.9408	772.1703	164.8854	4311.5809	65.6626	0.1743	1.4107	3.1761
mo_nn	141972	41	5.0000	1465.2174	160.8499	11283.2229	106.2225	0.2819	2.8825	15.5399
mo_id	141972	41	34.0968	904.2749	160.8837	4456.1507	66.7544	0.1772	1.7591	5.8549
moppm	253772	42	48.1285	794.9545	288.3275	14571.9035	120.7141	0.2396	0.3891	-0.2716
mo_nn	253772	42	5.0000	1602.4000	286.6276	33412.3305	182.7904	0.3629	1.4437	3.0061
mo_id	253772	42	28.8760	1065.9399	289.3135	14825.1567	121.7586	0.2417	0.4405	-0.1267
moppm	85269	43	59.2637	789.0280	330.2710	12363.8914	111.1930	0.3808	0.6136	0.0558
mo_nn	85269	43	20.0000	1286.8000	321.6009	35292.0503	187.8618	0.6433	1.4763	2.9768
mo_id	85269	43	29.5314	964.9471	329.9671	14345.7868	119.7739	0.4102	0.7038	0.5028
moppm	727	45	30.0000	30.0000	30.0000	-	-	-	-	-
mo_nn	727	45	6.9565	76.0000	19.6148	87.2657	9.3416	0.3465	1.3300	2.9829
mo_id	727	45	11.3303	47.3812	21.4700	74.6083	8.6376	0.3204	1.3512	0.5486

**Notes:**

moppm = molybdenum grade by Ordinary Kriging.

mo\_nn = molybdenum grade by Nearest Neighbour.

mo\_id = molybdenum grade by Inverse Distance squared.

A grade of 30 ppm molybdenum was assigned to molybdenum Domain 45, and not interpolated by OK.

**Table 17.11.4 Block Statistics for Specific Gravity by Domain**

FIELD	NRECORDS	NSAMPLES	SGZONE	MINIMUM	MAXIMUM	MEAN	VARIANCE	STANDDEV	STANDERR	SKEWNESS	KURTOSIS
sg	612953	102900	1	2.3458	2.7688	2.5966	0.0033	0.0575	0.0002	-0.3024	-0.4581
sg_adj	612953	102900	1	2.3224	2.7411	2.5706	0.0032	0.0569	0.0002	-0.3024	-0.4581
sg_nn	612953	102900	1	1.9990	4.4280	2.6026	0.0139	0.1179	0.0004	1.7223	30.4416
sg_id	612953	102900	1	2.1154	3.3272	2.6029	0.0050	0.0709	0.0002	-0.1844	0.2036
sg	612953	290809	2	2.4185	2.8170	2.5783	0.0018	0.0421	0.0001	0.4130	0.5593
sg_adj	612953	290809	2	2.3943	2.7889	2.5526	0.0017	0.0417	0.0001	0.4130	0.5593
sg_nn	612953	290809	2	2.2130	3.7060	2.5772	0.0057	0.0753	0.0001	1.2502	12.8001
sg_id	612953	290809	2	2.3107	3.5082	2.5769	0.0022	0.0470	0.0001	0.5682	2.7903
sg	612953	219244	3	2.4502	3.0292	2.7213	0.0109	0.1043	0.0002	0.2018	-0.6021
sg_adj	612953	219244	3	2.4257	2.9989	2.6941	0.0107	0.1032	0.0002	0.2018	-0.6021
sg_nn	612953	219244	3	2.1420	4.0930	2.7289	0.0348	0.1866	0.0004	1.1324	5.5661
sg_id	612953	219244	3	2.2059	3.8449	2.7310	0.0181	0.1346	0.0003	0.5600	0.2280

**Notes:**

sg = Specific Gravity by Ordinary Kriging.

sg\_adj = sg multiplied by 0.99.

sg\_nn = Specific Gravity by Nearest Neighbour.

sg\_id = Specific Gravity by Inverse Distance squared.



Figure 17.11.1 Ordinary Kriging Copper Section at 2156000 ft N with Corresponding Sample Data at ±150 ft Clipping Distance

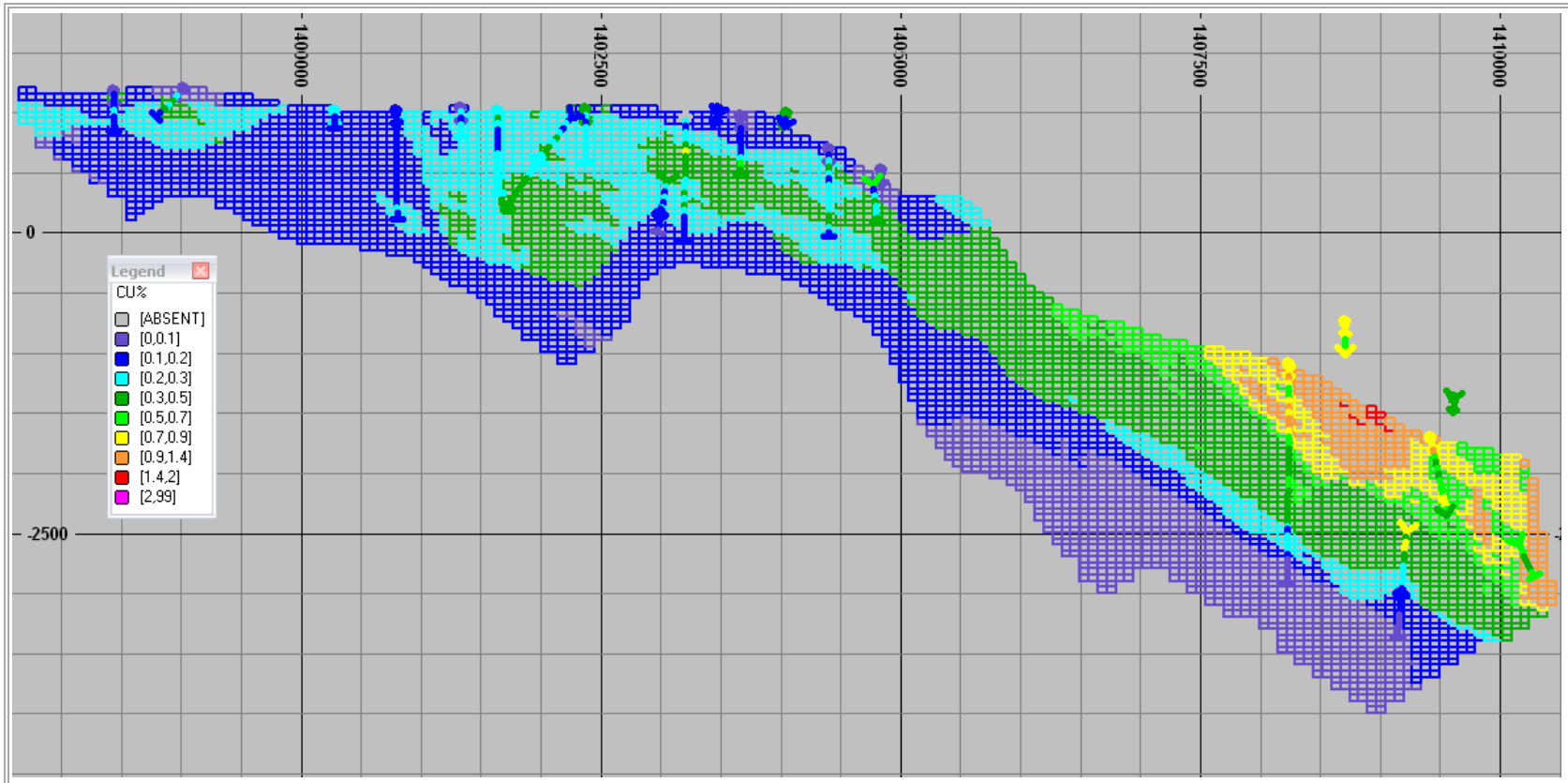


Figure 17.11.2 Ordinary Krigge Copper Section at 2157000 ft N with Corresponding Sample Data at ±150 ft Clipping Distance

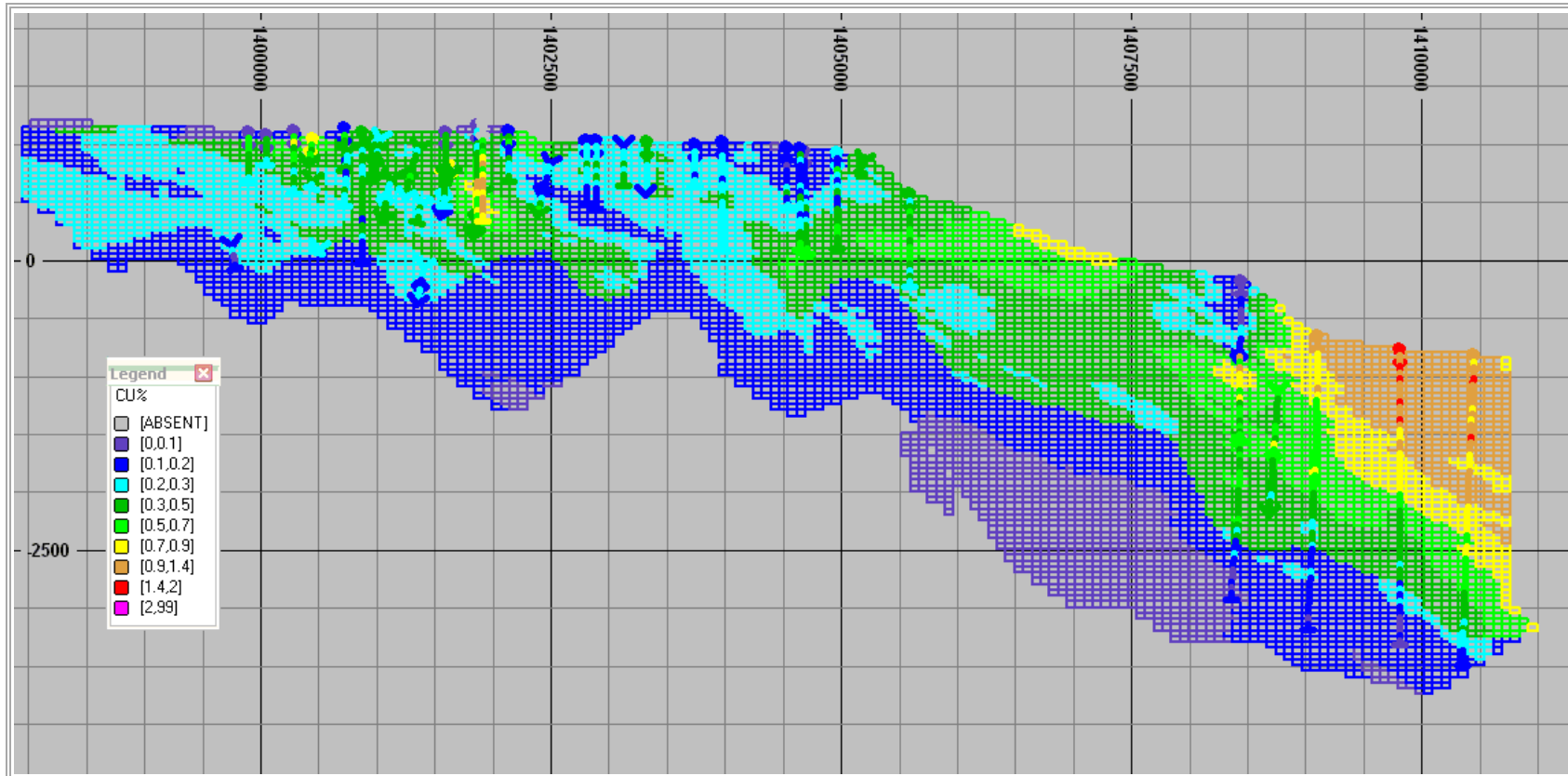


Figure 17.11.3 Ordinary Kriging Copper Section at 2158000 ft N with Corresponding Sample Data at ±150 ft Clipping Distance

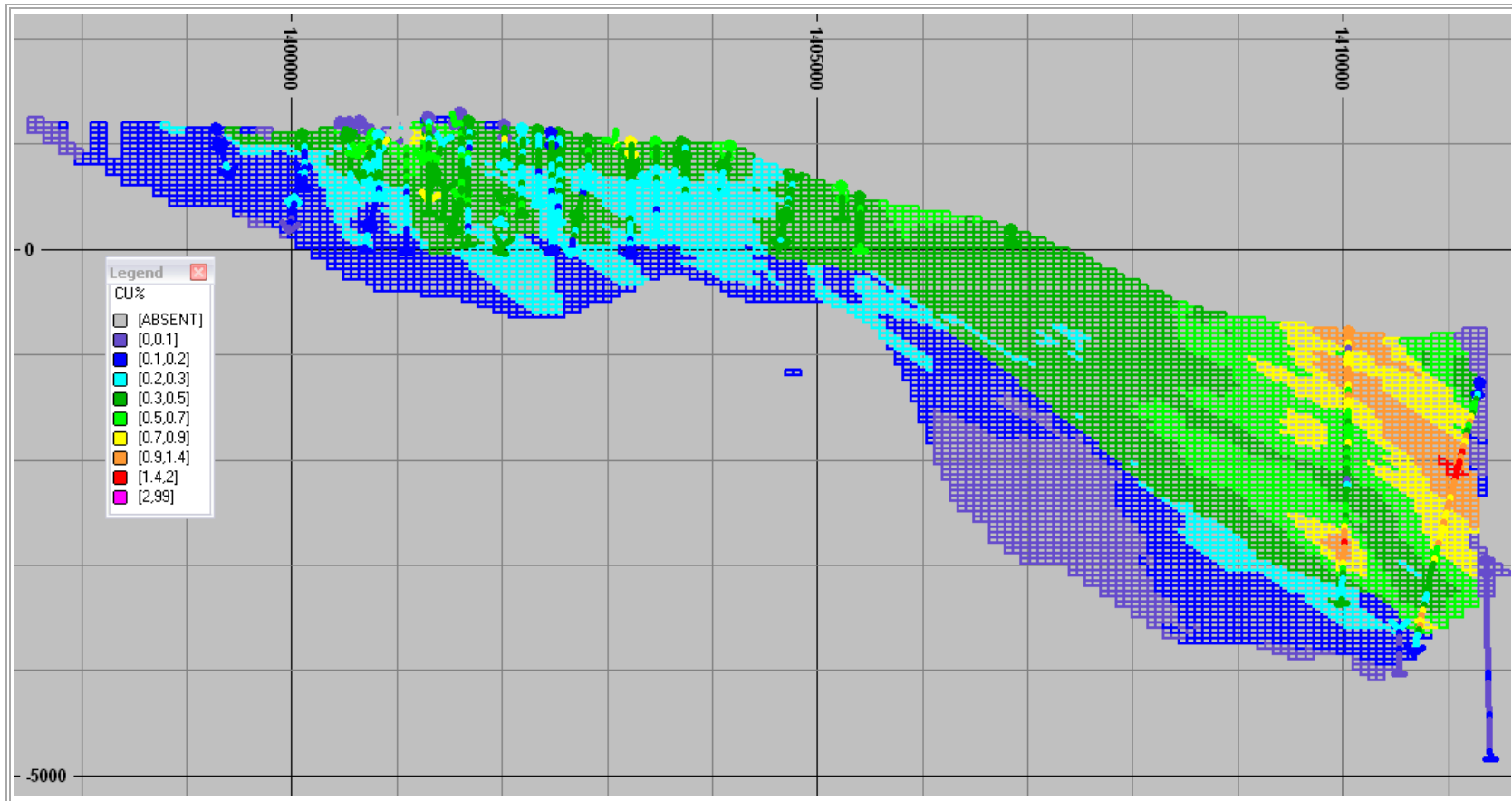


Figure 17.11.4 Ordinary Kriging Gold Section at 2156000 ft N with Corresponding Sample Data at ±150 ft Clipping Distance

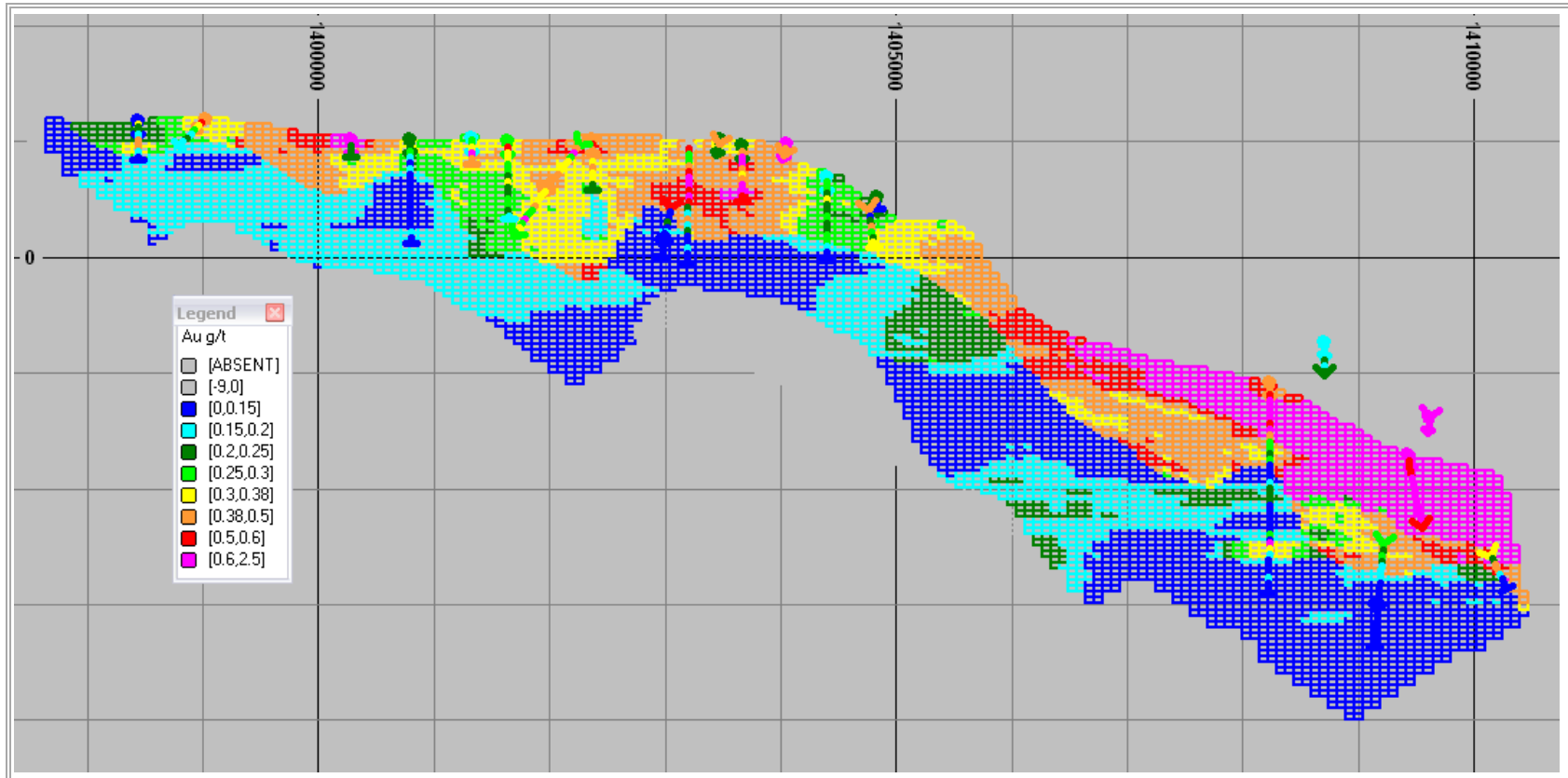


Figure 17.11.5 Ordinary Krigge Gold Section at 2157000 ft N with Corresponding Sample Data at ±150 ft Clipping Distance

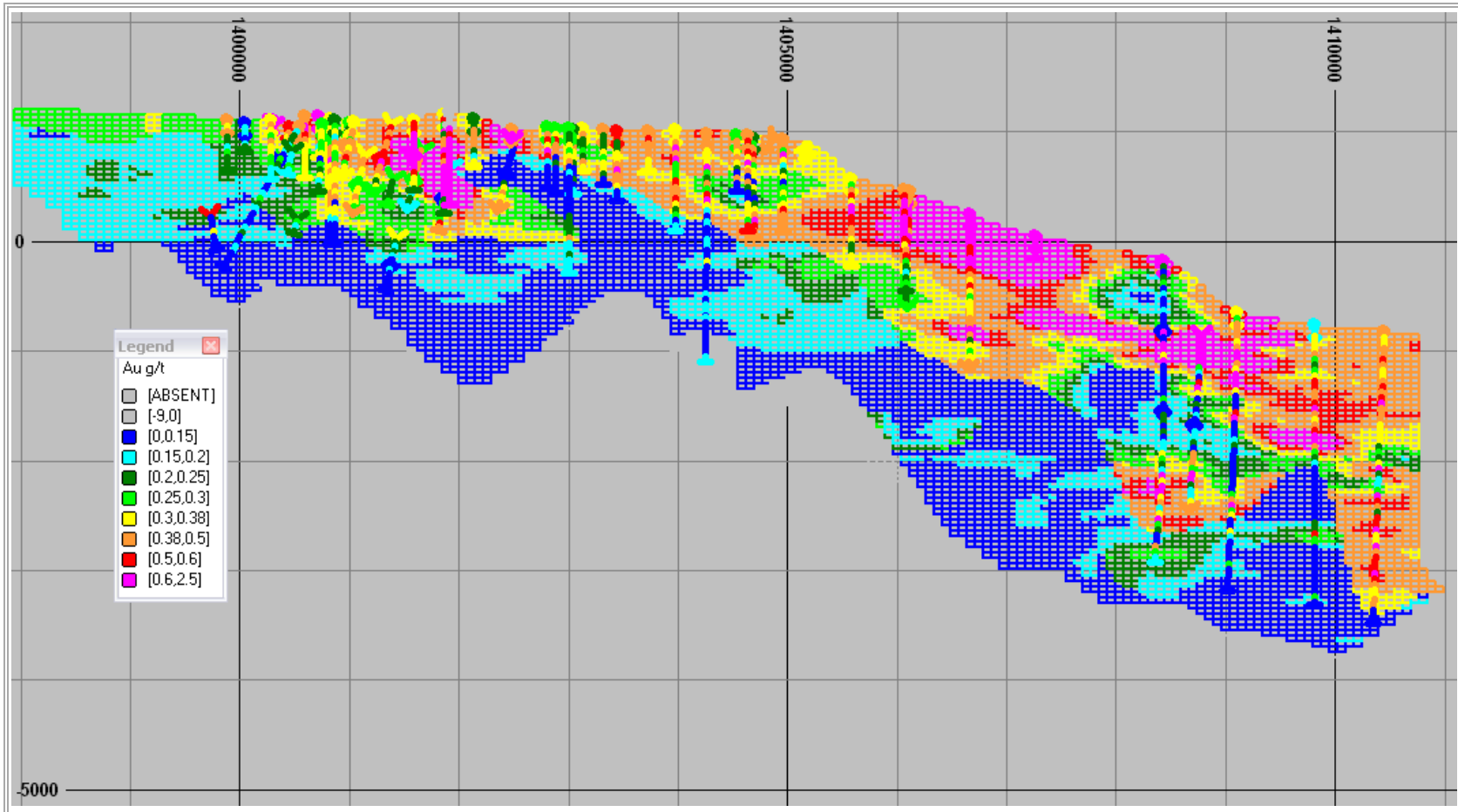


Figure 17.11.6 Ordinary Kriged Gold Section at 2158000 ft N with Corresponding Sample Data at ±150 ft Clipping Distance

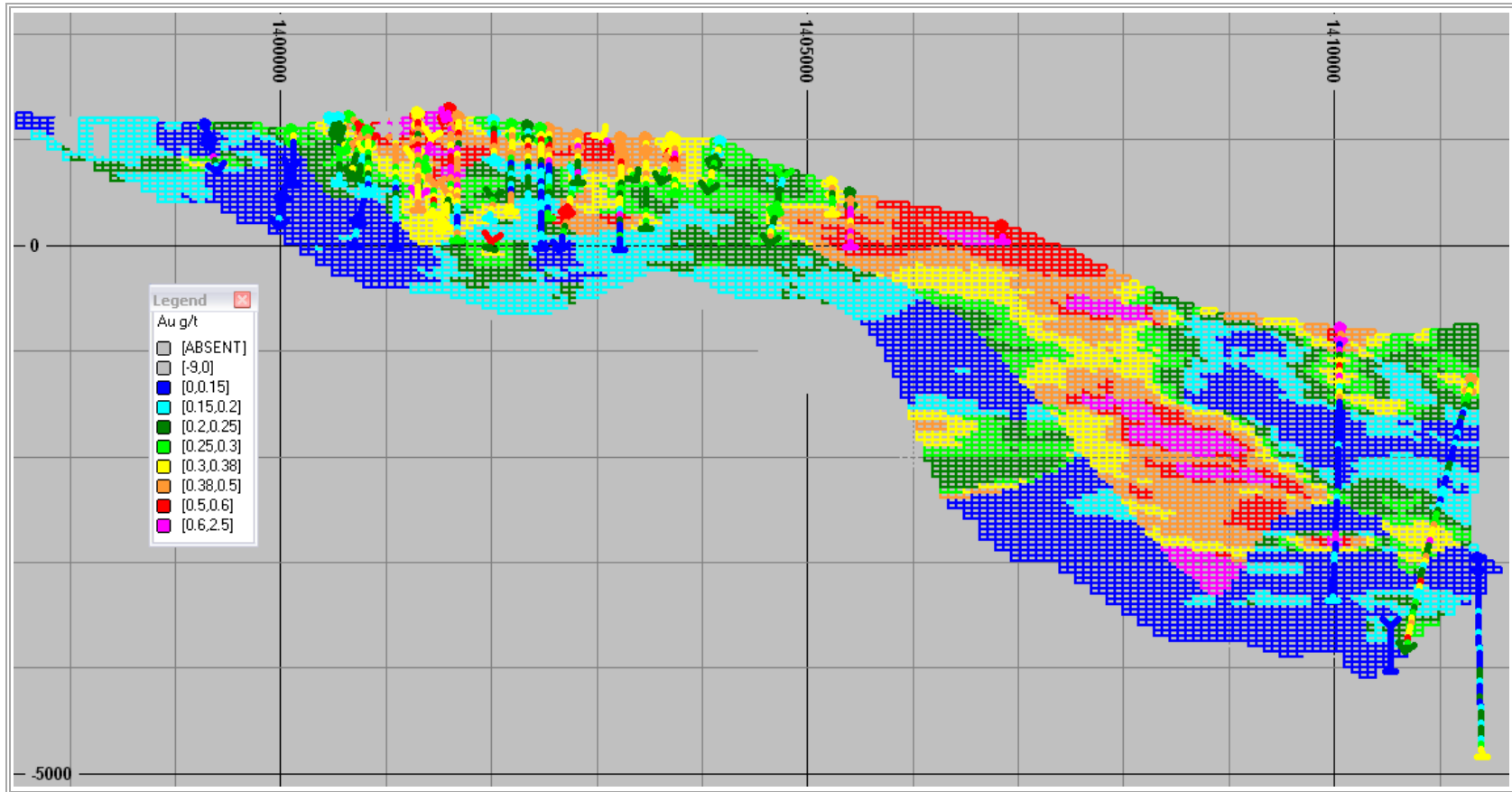


Figure 17.11.7 Ordinary Kriging Molybdenum Section at 2156000 ft N with Corresponding Sample Data at ±150 ft Clipping Distance

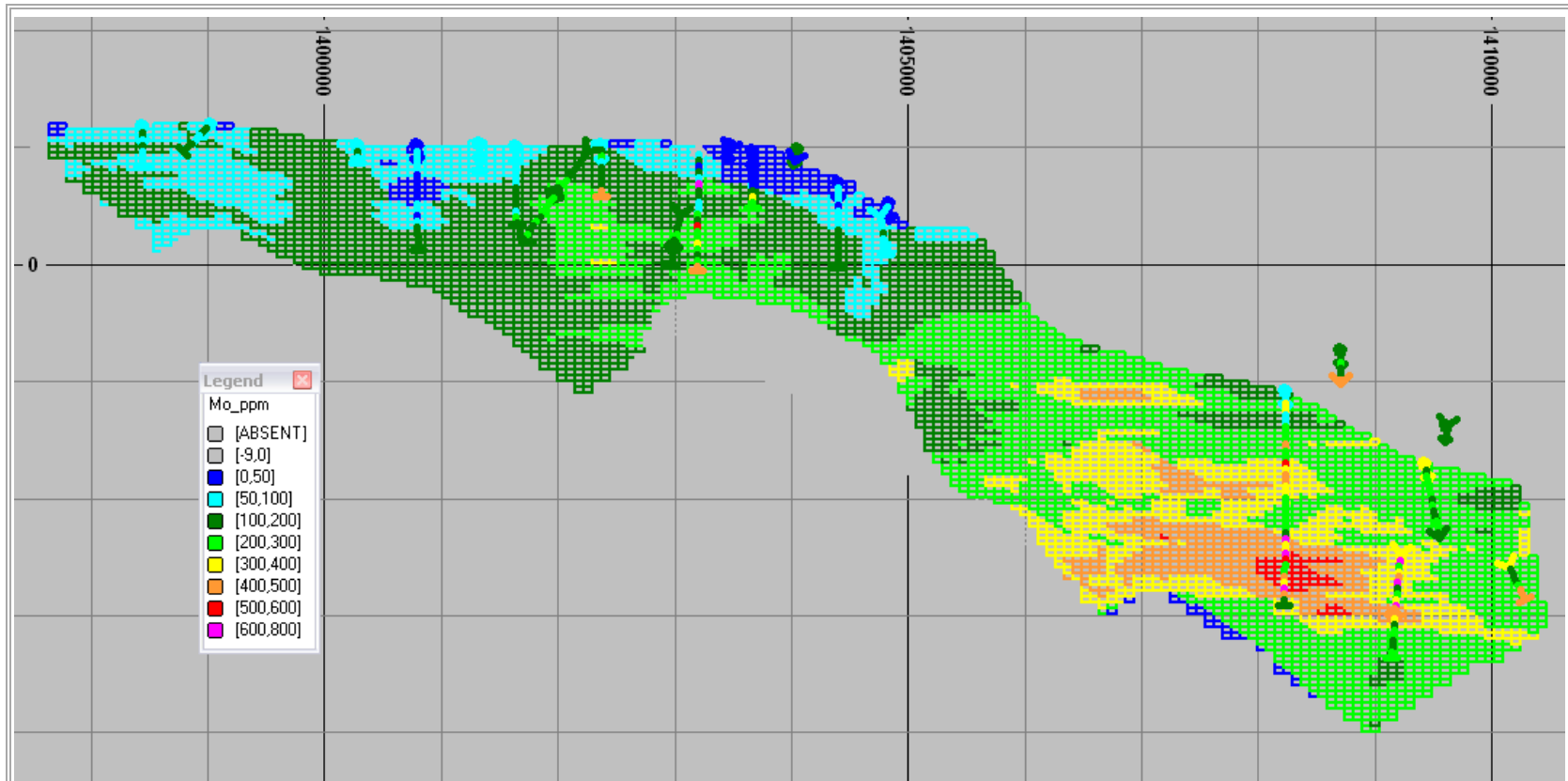


Figure 17.11.8 Ordinary Krigge Molybdenum Section at 2157000 ft N with Corresponding Sample Data at ±150 ft Clipping Distance

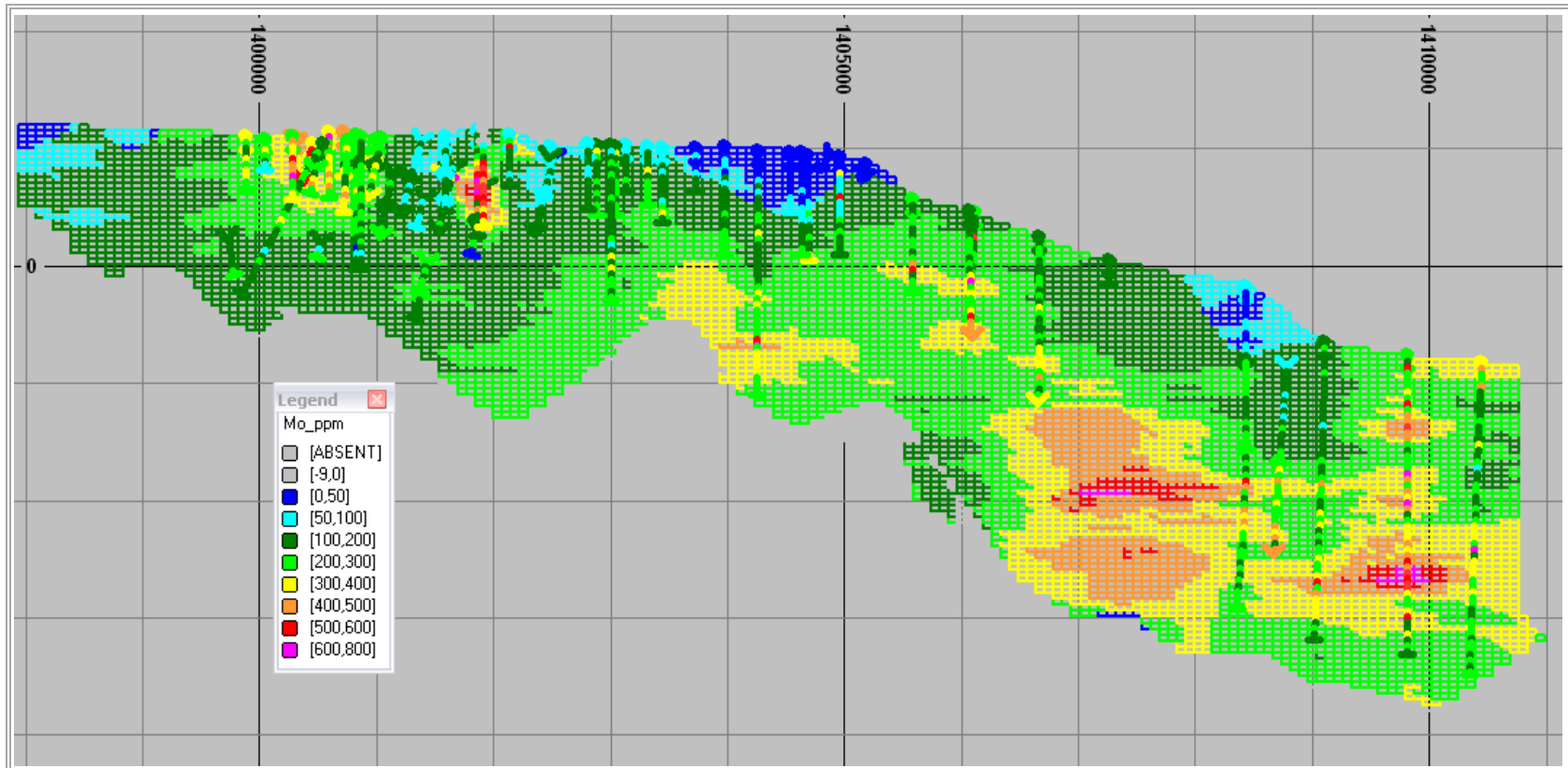




Figure 17.11.9 Ordinary Kriging Molybdenum Section at 2158000 ft N with Corresponding Sample Data at ±150 ft Clipping Distance

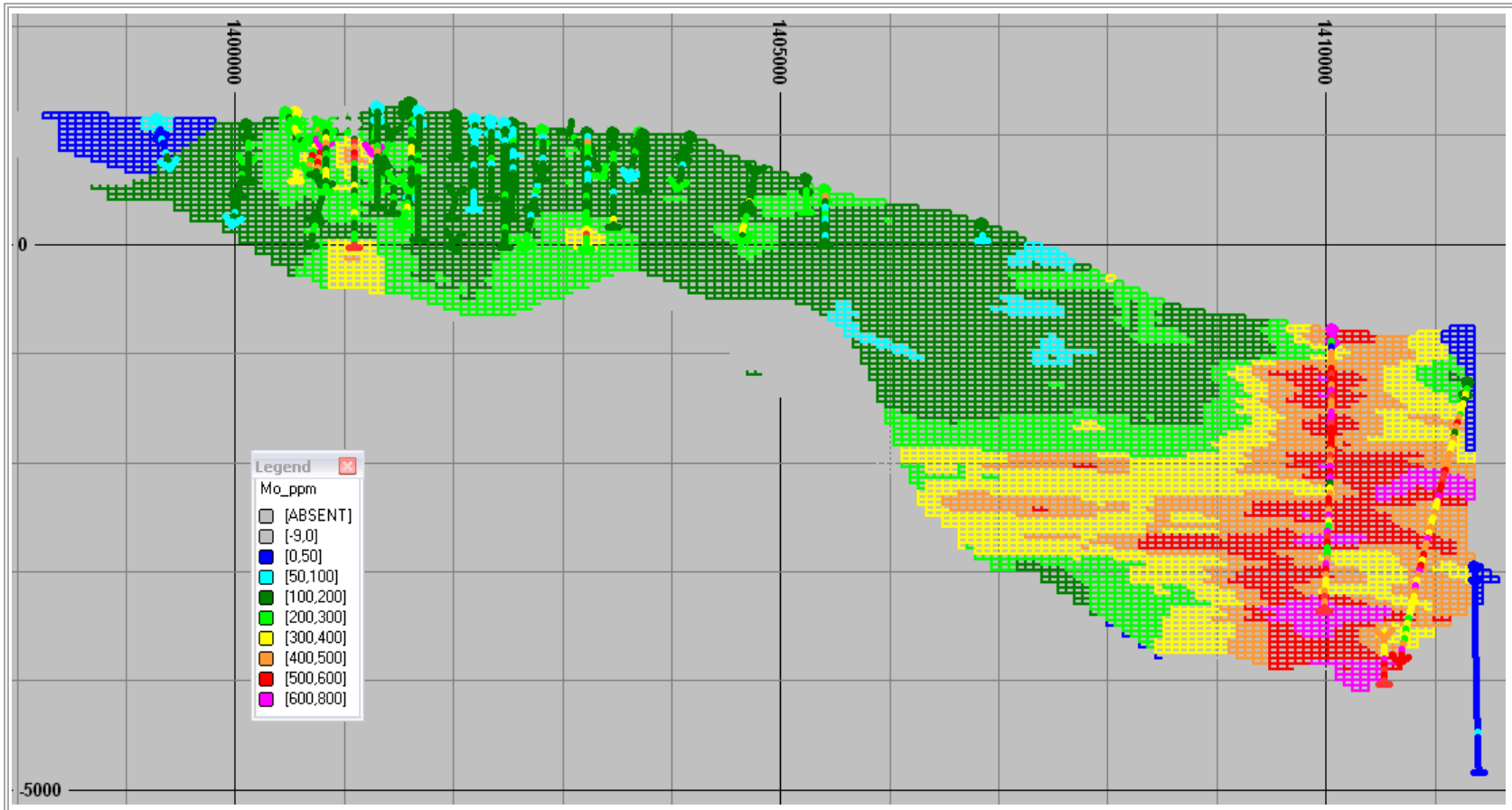


Figure 17.11.10 Ordinary Krigge Density (SG) Section at 2156000 ft N with Corresponding Sample Data at ±150 ft Clipping Distance

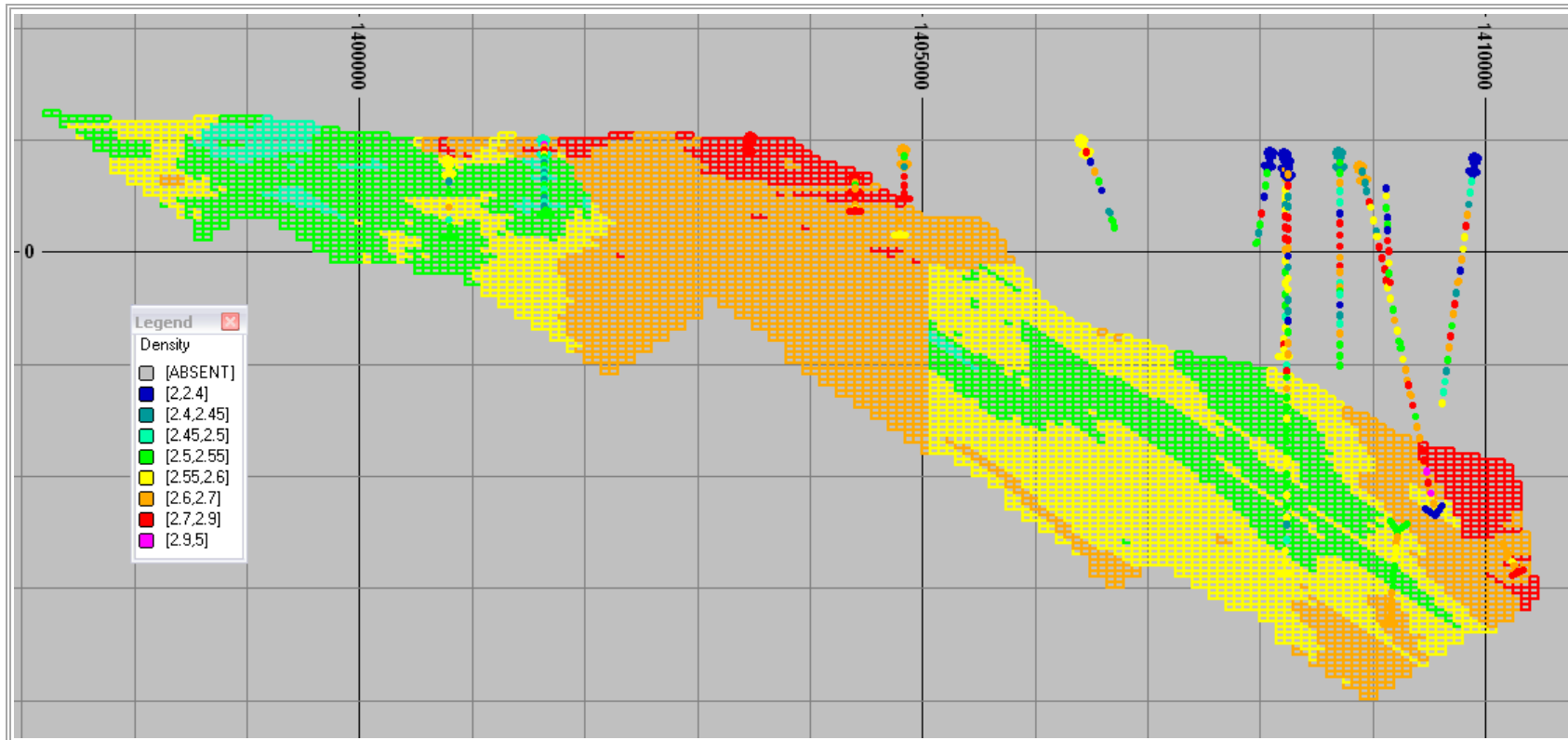


Figure 17.11.11 Ordinary Krigge Density (SG) Section at 2157000 ft N with Corresponding Sample Data at ±150 ft Clipping Distance

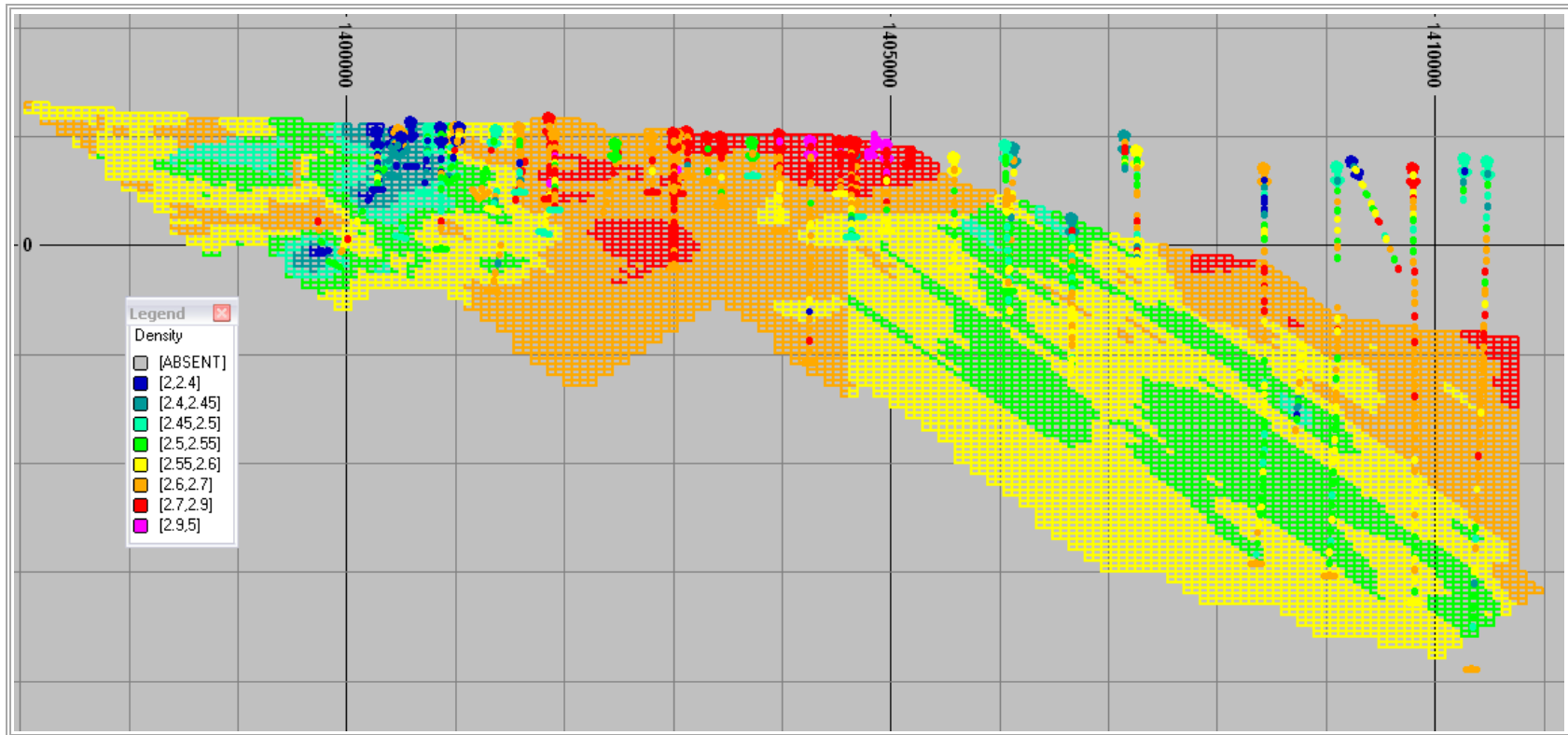
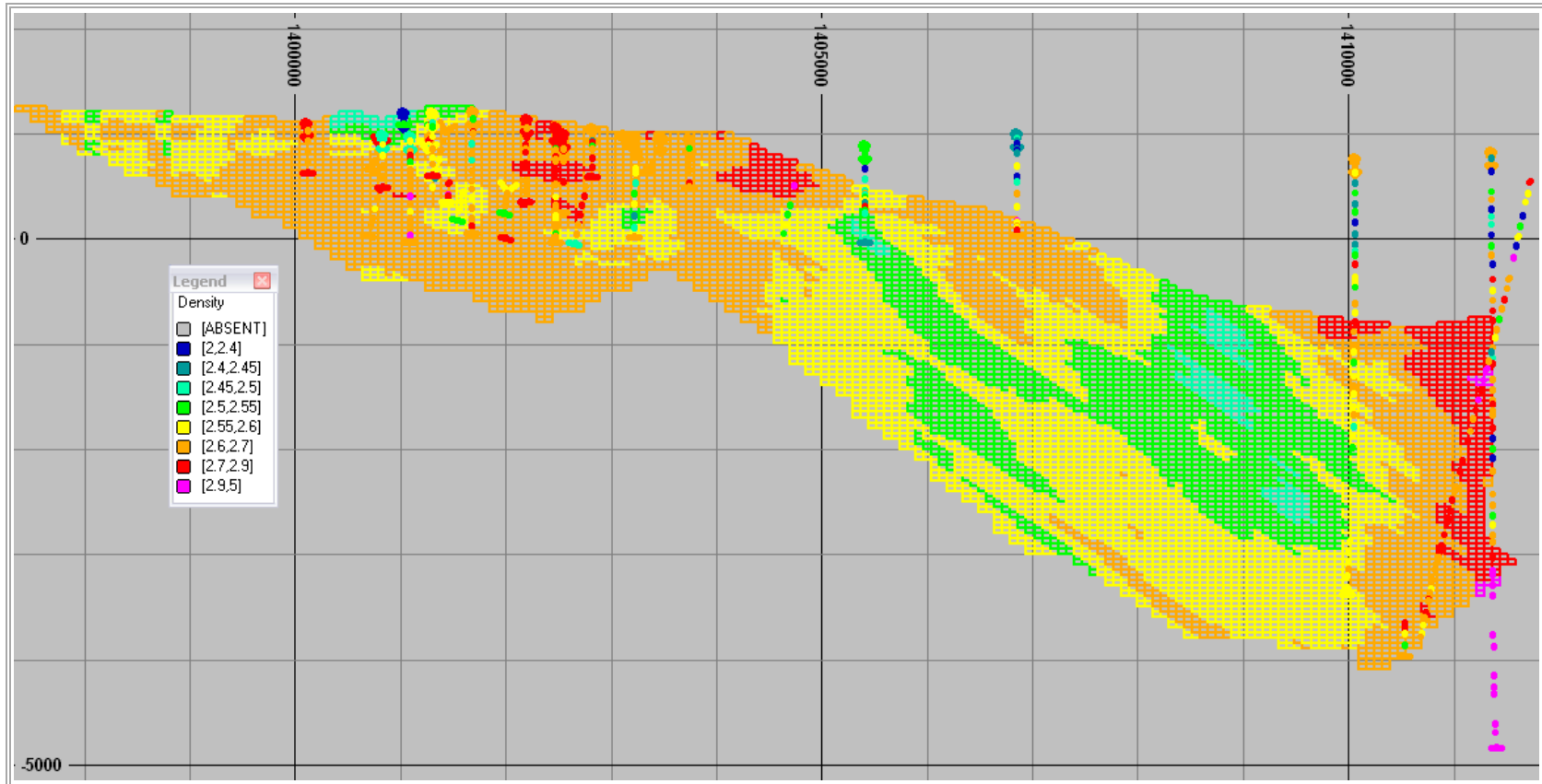


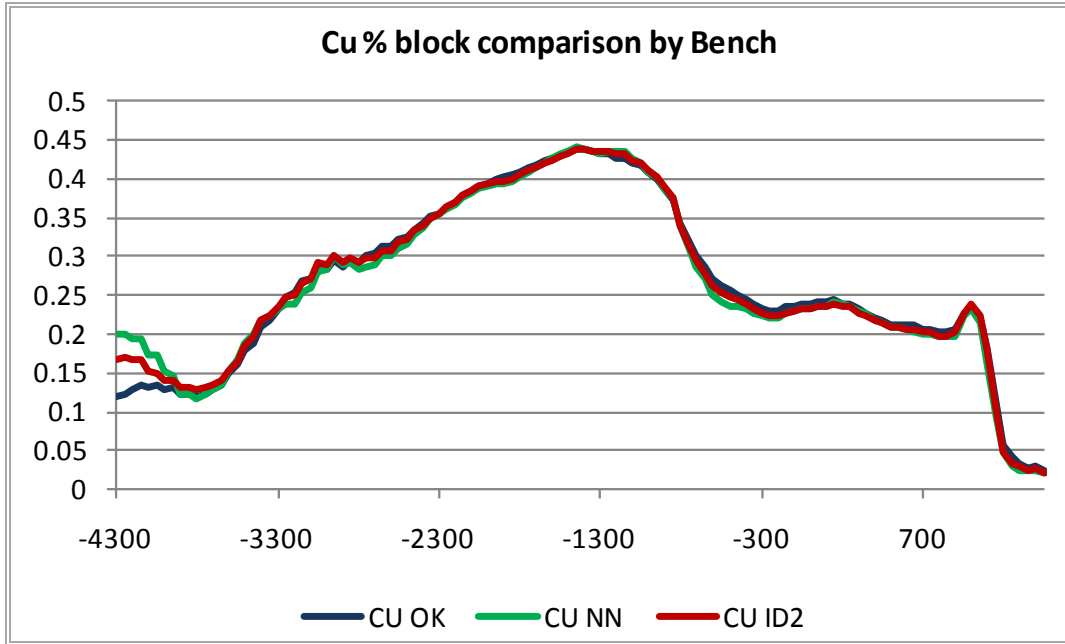
Figure 17.11.12 Ordinary Krigge Density (SG) Section at 2158000 ft N with Corresponding Sample Data at ±150 ft Clipping Distance



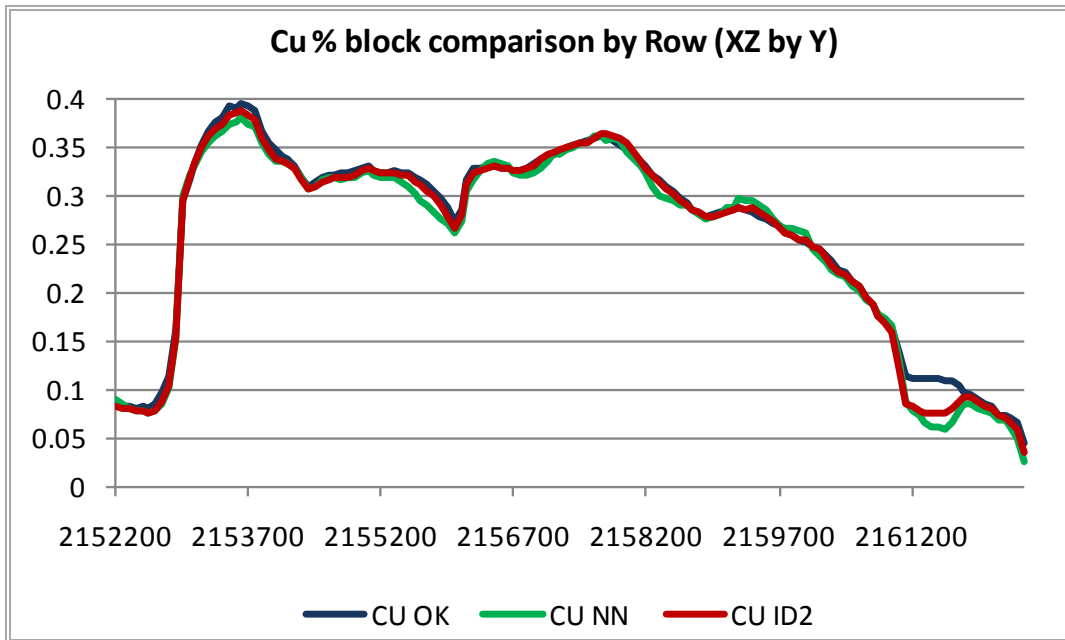
**17.11.3 SWATHS PLOTS**

Comparative swath plots are presented in this section.

**Figure 17.11.13 Copper Model Swaths Plot by Bench (Z)**



**Figure 17.11.14 Copper Model Swaths Plot by Row (Y)**



Copper swaths by bench and northing show good correlation between the different interpolation methods. They only diverge in the deposit extremities (at depth and to the north) where sample selection is more distal. Note that highest grade copper by easting is recorded marginally by OK (Figure 17.11.15).

Figure 17.11.15 Copper Model Swaths Plot by Column (X)

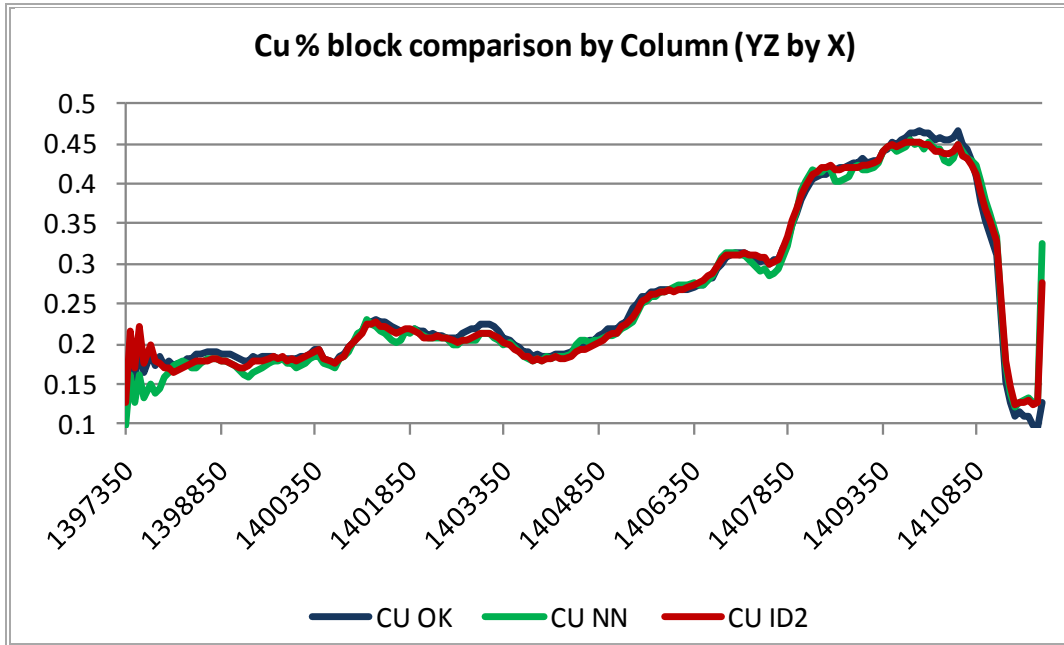


Figure 17.11.16 Gold Model Swaths Plots by Bench (Z)

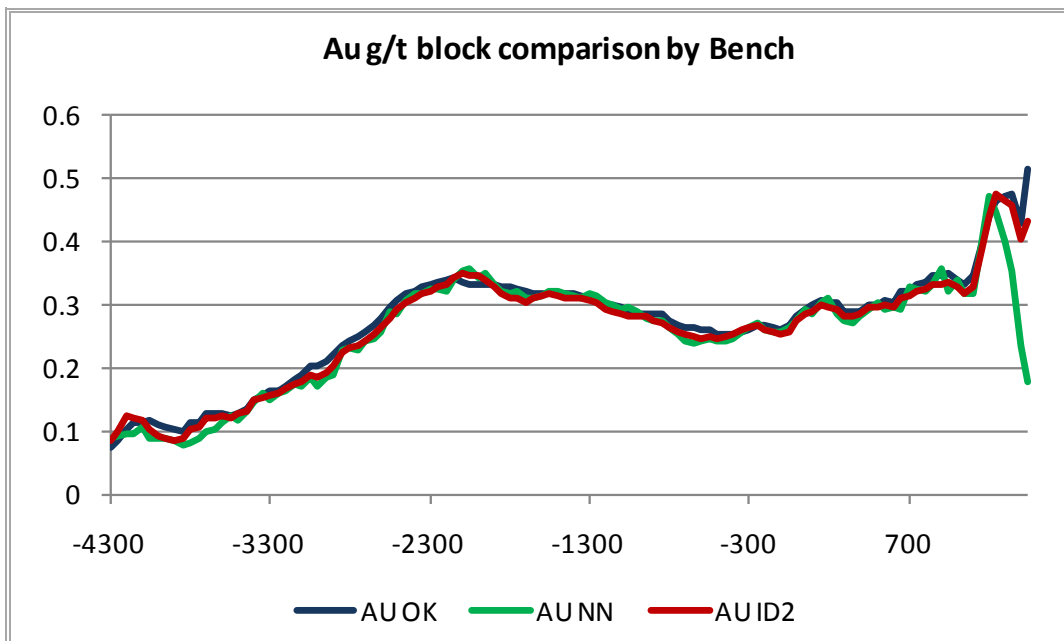


Figure 17.11.17 Gold Model Swaths Plots by Row (Y)

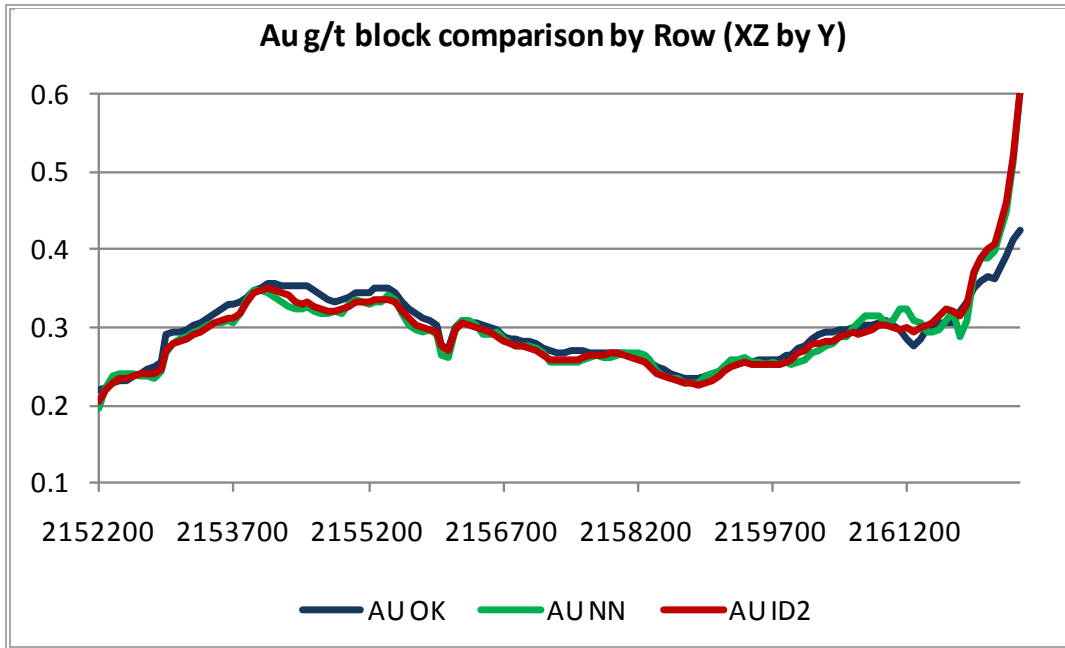
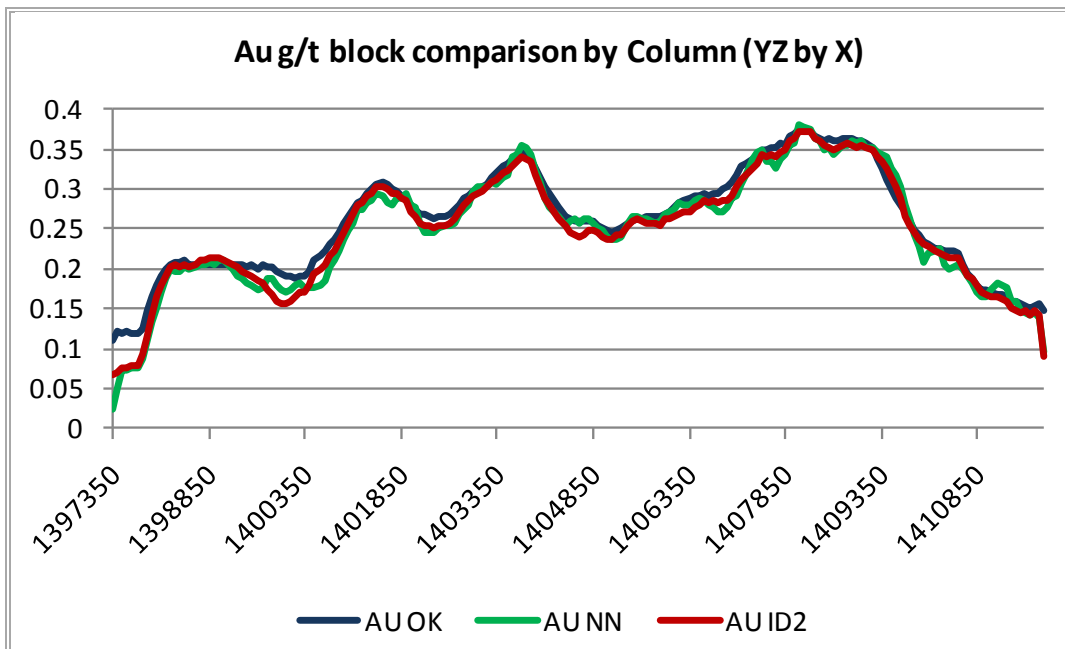


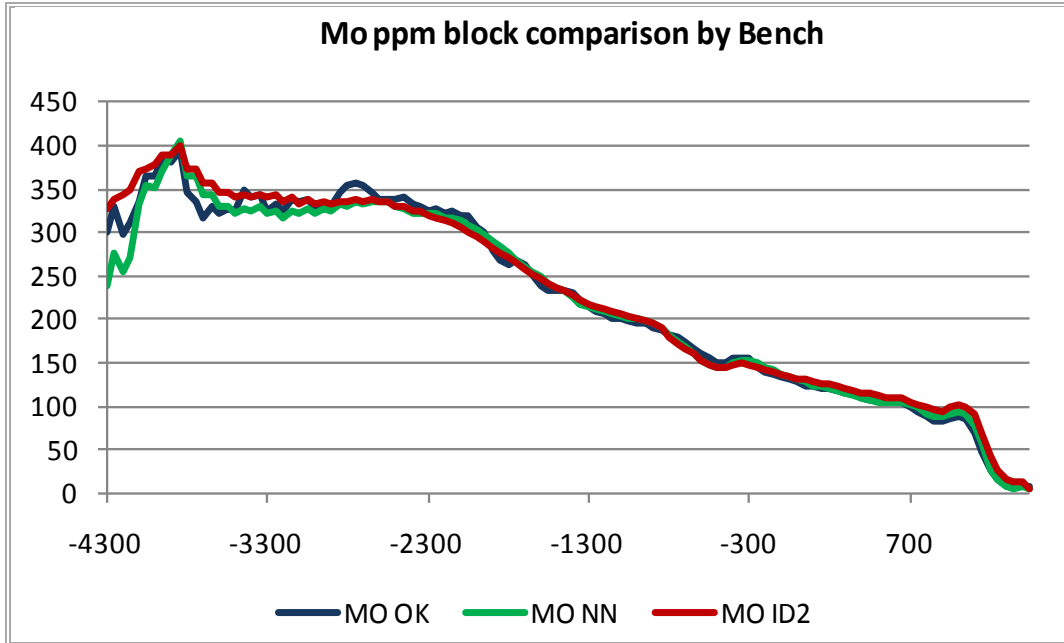
Figure 17.11.18 Gold Model Swaths Plots by Column (X)



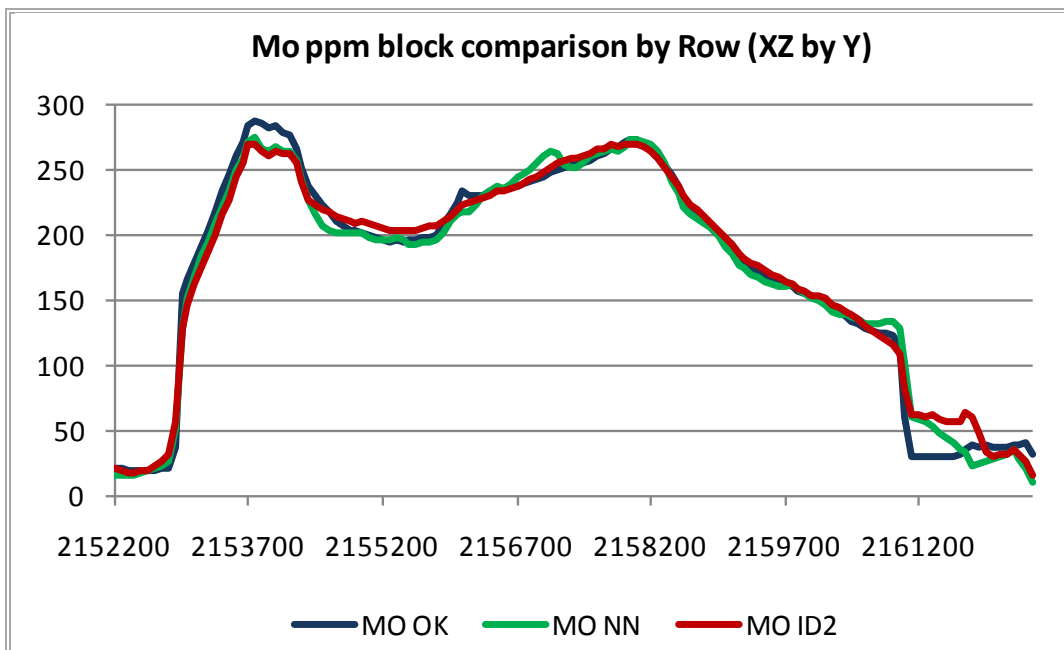
Like copper, gold shows good correlation between all the interpolation methods. As expected, the polygonal estimator (Nearest Neighbour) shows the most variability. Greatest discrepancies are along the margins of the deposit where sample selection strategies and search passes are of a more

significant influence. Like copper as well, it is interesting to note that OK is often the slightly higher grade interpolation method.

**Figure 17.11.19 Molybdenum Model Grade Swaths Plot by Bench (Z)**



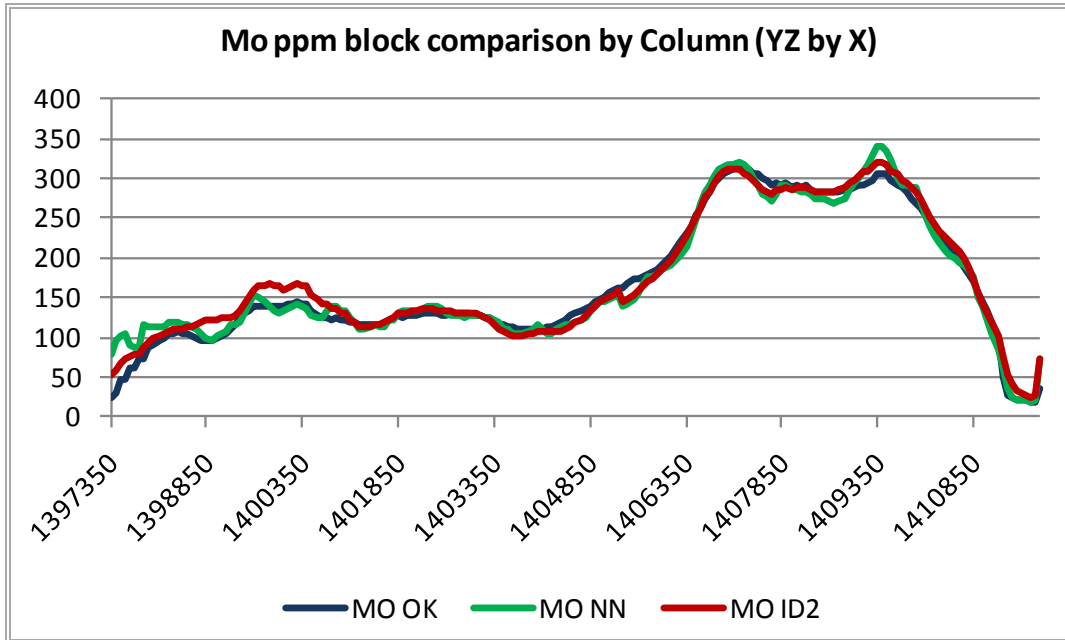
**Figure 17.11.20 Molybdenum Grade Swaths Plot by Row (XZ by Y)**





Molybdenum shows erratic correlation between the interpolators at depth and at higher grades. This may demonstrate the fundamental difference in the weighting strategy between Inverse Distance Squared.

**Figure 17.11.21 Molybdenum Grade Swaths Plot by Column (YX by X)**



**Figure 17.11.22 Specific Gravity Swath Plot by Bench (Z)**

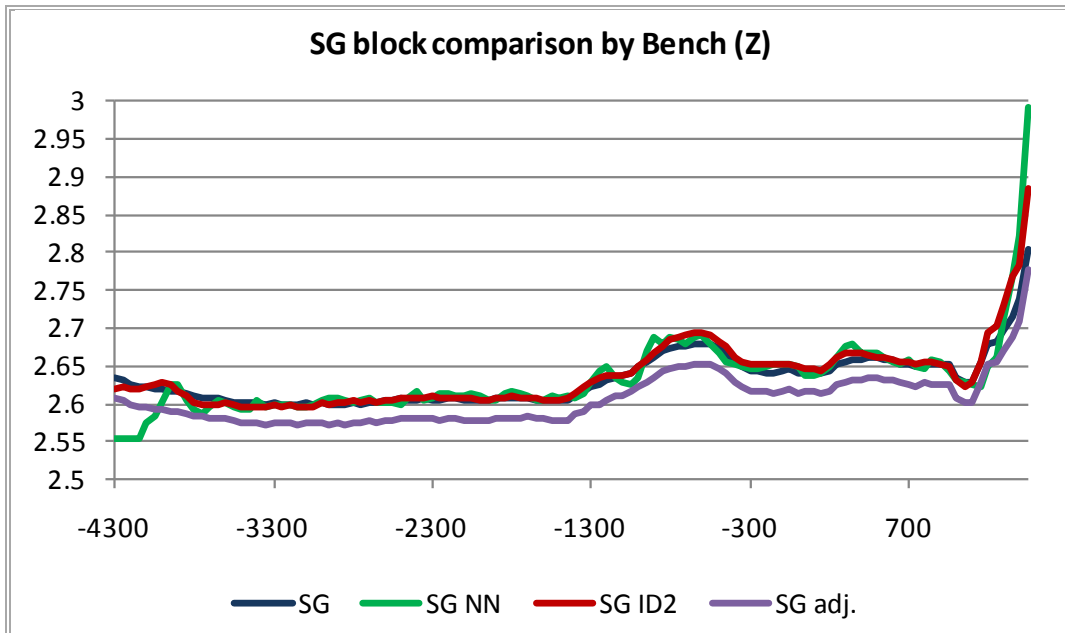


Figure 17.11.23 Specific Gravity Swath Plot by Row (XZ by Y)

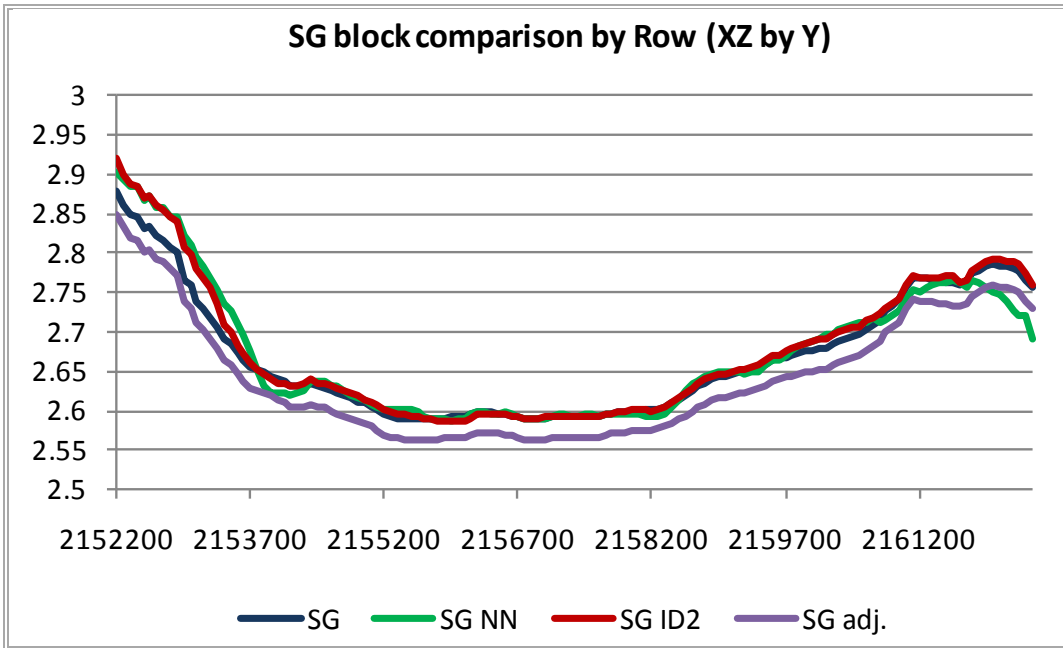
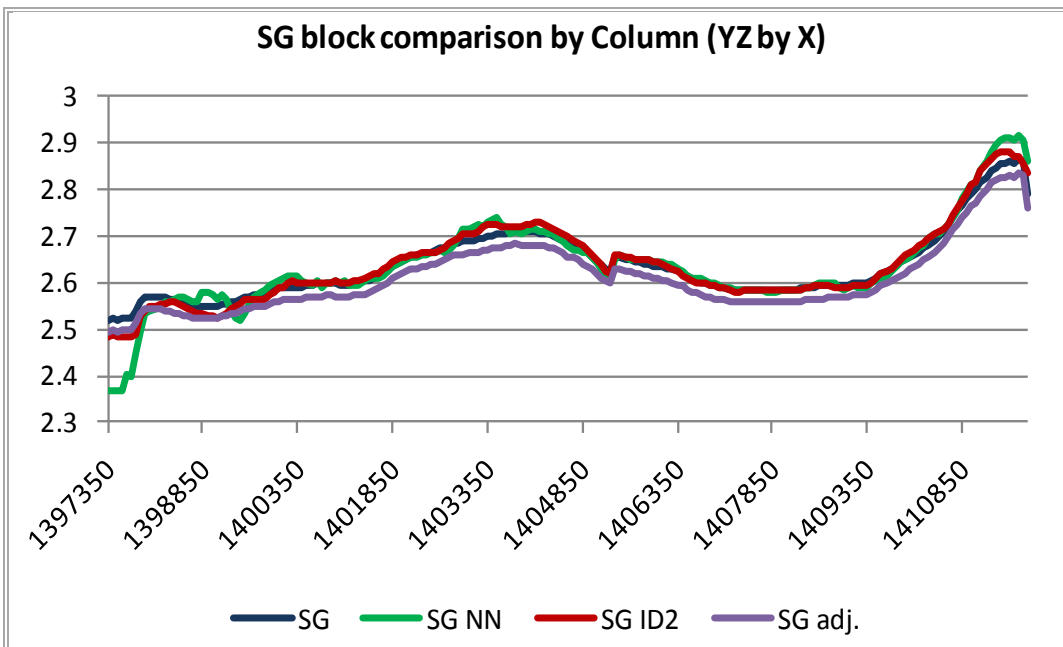


Figure 17.11.24 Specific Gravity Swath Plot by Column (YZ by X)



**17.11.4 ORDINARY KRIGING SENSITIVITY ANALYSIS**

Of the fourteen estimated metal domains, eight used variograms with the total modeled variance less than that of the representative sample dataset (respective Domain composited and capped drill hole data). These domains are shown in Table 17.11.5.

**Table 17.11.5 Variogram Model Variance with Respect to Total Variance of the Corresponding Sample Data (Normalized to One)**

Domain	Nugget	#Structures	Sill_differential1	Sill_differential2	Total Variance
auzone40	0.46	1	0.54		1
auzone41	0.16	2	0.26	0.29	0.71
auzone42	0.43	1	0.57		1
auzone43	0.2	1	0.7		0.9
cuzone1	0.31	2	0.48	0.21	1
cuzone2	0.4	1	0.6		1
cuzone40	0.15	1	0.6		0.75
cuzone41	0.11	2	0.25	0.3	0.66
cuzone42	0.13	2	0.12	0.3	0.55
cuzone43	0.12	1	0.49		0.61
mozzone40	0.28	1	0.72		1
mozzone41	0.19	2	0.16	0.3	0.65
mozzone42	0.38	2	0.19	0.35	0.92
mozzone43	0.47	2	0.23	0.3	1

As variance is a function of the mean grade of samples, a sensitivity analysis was undertaken to evaluate if there was any significant material change (grade) in comparison to a block model with all modeled domain variances (i.e. total model sill) equal to that of the corresponding sample variance (i.e. the experimental sill).

Using Datamine™, variograms were constructed for all domains, and respective variography parameter files prepared. The search and sample selection parameters and the target block model are the same as those in the original Vulcan™-based Ordinary Kriged block model. Molybdenum Domain 45 was estimated, and not assigned the mean grade value as in the Vulcan™ resource model, as a check on this interpolation strategy. Statistical summary of the relative comparison of the two Ordinary Kriged estimates is shown in Table 17.11.6.

**Table 17.11.6 Comparison between Two Ordinary Kriged Block Models as Percentage Difference\***

Domain	40	40	41	41	42	42	43	43	45	45
FIELD	cupct	cu_ok	cupct	cu_ok	cupct	cu_ok	cupct	cu_ok		
NRECORDS	295553	295553	85247	85247	163647	163647	61661	61661	-	-
NSAMPLES	295553	285914	85247	85247	163647	163647	61661	61661	-	-
NMISVALS	0	9639	0	0	0	0	0	0	-	-
MINIMUM	0.0069	0.0013	0.0932	0.0807	0.0944	0.0765	0.2061	0.1830	-	-
MAXIMUM	0.3263	0.5140	0.9644	0.8729	1.7157	1.6412	1.9820	2.0307	-	-
MEAN	0.1228	0.1179	0.2902	0.2818	0.5160	0.5158	0.6085	0.6042	-	-
VARIANCE	0.0026	0.0032	0.0060	0.0051	0.0488	0.0484	0.0531	0.0528	-	-
STANDDEV	0.0515	0.0566	0.0774	0.0715	0.2209	0.2200	0.2305	0.2297	-	-
STANDERR	0.0001	0.0001	0.0003	0.0002	0.0005	0.0005	0.0009	0.0009	-	-
SKEWNESS	-0.0021	0.2963	1.6763	1.1895	1.2154	1.1482	1.2368	1.5163	-	-
KURTOSIS	-0.6551	0.0728	5.4251	3.2890	1.5476	1.4501	2.2802	3.6547	-	-
FIELD	mopppm	mo_ok	mopppm	mo_ok	mopppm	mo_ok	mopppm	mo_ok	mopppm	mo_ok
NRECORDS	131735	131735	141972	141972	253772	253772	85269	85269	727	727
NSAMPLES	131735	130894	141972	141972	253772	253772	85269	85269	727	727
NMISVALS	0	841	0	0	0	0	0	0	0	0
MINIMUM	0.71	0.87	43.94	34.01	48.13	34.13	59.26	76.04	30.00	12.82
MAXIMUM	137.93	148.03	772.17	874.25	794.95	905.64	789.03	819.55	30.00	38.09
MEAN	31.24	28.28	164.89	162.07	288.33	287.94	330.27	329.37	30.00	20.78
VARIANCE	283.31	425.25	4311.58	4677.53	14571.90	15573.61	12363.89	10863.02	-	40.93
STANDDEV	16.83	20.62	65.66	68.39	120.71	124.79	111.19	104.23	-	6.40
STANDERR	0.0464	0.0570	0.1743	0.1815	0.2396	0.2477	0.3808	0.3569	-	0.2373
SKEWNESS	0.6317	0.7940	1.4107	1.7335	0.3891	0.5505	0.6136	0.8407	-	1.2916
KURTOSIS	0.4061	0.0875	3.1761	5.2074	-0.2716	0.0903	0.0558	0.8214	-	0.5059

Table continues...

...Table 17.11.6 (cont'd)

Domain	40	40	41	41	42	42	43	43	45	45
FIELD	augpt	au_ok	augpt	au_ok	augpt	au_ok	augpt	au_ok		
NRECORDS	244240	244240	110526	110526	196900	196900	61809	61809		
NSAMPLES	244240	244210	110526	110526	196900	196900	61809	61809		
NMISVALS	0	30	0	0	0	0	0	0		
MINIMUM	0.0257	0.0081	0.1152	0.0876	0.0376	0.0245	0.0674	0.0697		
MAXIMUM	0.7401	0.7215	1.8155	1.8208	1.9224	1.9647	2.0616	1.8489		
MEAN	0.1561	0.1480	0.3700	0.3582	0.3514	0.3492	0.4637	0.4504		
VARIANCE	0.0033	0.0056	0.0154	0.0172	0.0325	0.0351	0.0676	0.0627		
STANDDEV	0.0577	0.0748	0.1240	0.1310	0.1803	0.1875	0.2601	0.2505		
STANDERR	0.0001	0.0002	0.0004	0.0004	0.0004	0.0004	0.0010	0.0010		
SKEWNESS	1.4880	2.0975	1.5929	1.5470	1.1254	1.0836	1.6678	1.3442		
KURTOSIS	5.7051	8.2004	5.6304	5.6670	2.6015	2.8275	3.6712	1.9284		

\* Negative values indicate higher relative percentage in the Datamine™ model, and positive values indicate higher relative percentage in the Vulcan™ model.

The Datamine estimation for copper Domains 1 and 2 were found to be erroneous due to wrong sample selection and hence invalid variograms. They were disqualified from the comparison.

Molybdenum Domain 45 was successfully interpolated using an isotropic variogram. The mean grade (~20 ppm) was significantly less than the average grade of the samples (~30 ppm) due to a skewed population.

The global estimate for the Pebble resource remains valid. However, the local block estimate in some Domains may be over-smoothed by an artificially lowered total modelled sill (variance) with respect to total sample.

## 17.12 RECOMMENDATIONS

---

### 17.12.1 SPECIFIC GRAVITY

The strategy to accommodate possibly erroneous specific gravity measurements by reducing all density by 1% may be excessive as it effectively reduces the total tonnage across the entire deposit (~107.8 million tonnes). As an alternative, Wardrop suggests that any erroneous measurements be identified and extirpated from the data, followed by replacement measurements from suitable drill core. The density data could then be used in subsequent resource models without the need to apply an arbitrary modifying factor.

### 17.12.2 CAPPING AND OUTLIER MANAGEMENT

A top-cut or “cap” has been applied to the raw sample data for the respective domains by estimating the break between a continuous and a discontinuous higher-grade sample population. The discontinuous higher-grade samples were considered outliers and an appropriate cap was applied. This is the most common way to cap the grades above a chosen threshold. For future resource estimations, it is suggested that a more rigorous and quantitative capping analysis be undertaken. One method is to use Monte Carlo simulation to “re-drill” the deposit 1,000 times, with each simulation being restricted to the number of samples typically “mined out” in an annual production increment. The tangible deliverable is to simulate the number of high-grade assays, assign grades to each by drawing at random from the distribution (Monte Carlo), and determine the metal represented by the high-grade material. This methodology is suitable where the highest grade assays occur independently in space (are not clustered), as is the case with the Pebble deposit.

### 17.12.3 VARIOGRAPHY

Wardrop recommends that domain variography is modelled to the total sill (variance) of the experimental (sample) data. If required, a sensitivity analysis should be completed to investigate over-smoothing in affected domains.

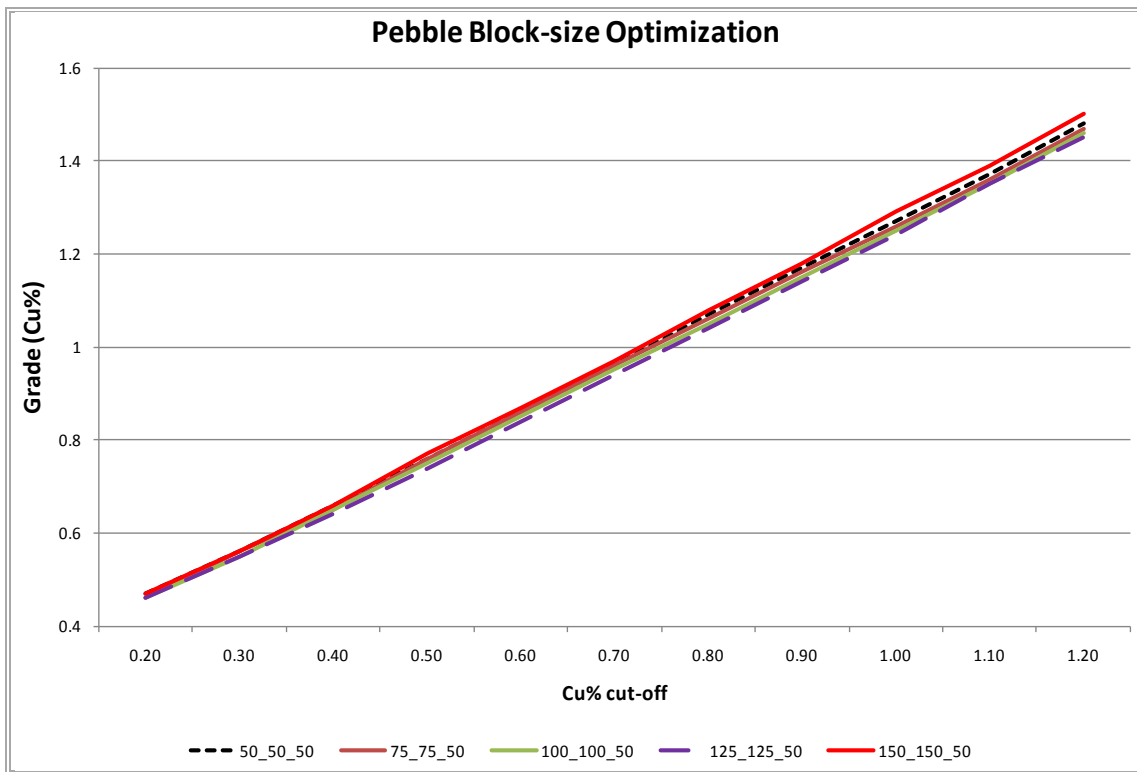
**17.12.4 MOLYBDENUM DOMAIN 45**

Due to the relatively small domain size and relative lack of samples, molybdenum Domain 45 (MOZONE 45) was assigned a molybdenum ppm value of 30 for all blocks (average molybdenum grade for domain samples is 32 ppm). Using a simple isotropic variogram, a comparative OK model in Datamine™ is capable of successful interpolation of grade into the blocks, which resulted in a lower average block grade (~20 ppm). It is suggested that Ordinary Kriging be employed in MOZONE 45, and if there are any blocks which fail to be interpolated by insufficient samples, then these blocks could be assigned the average grade of the interpolated blocks.

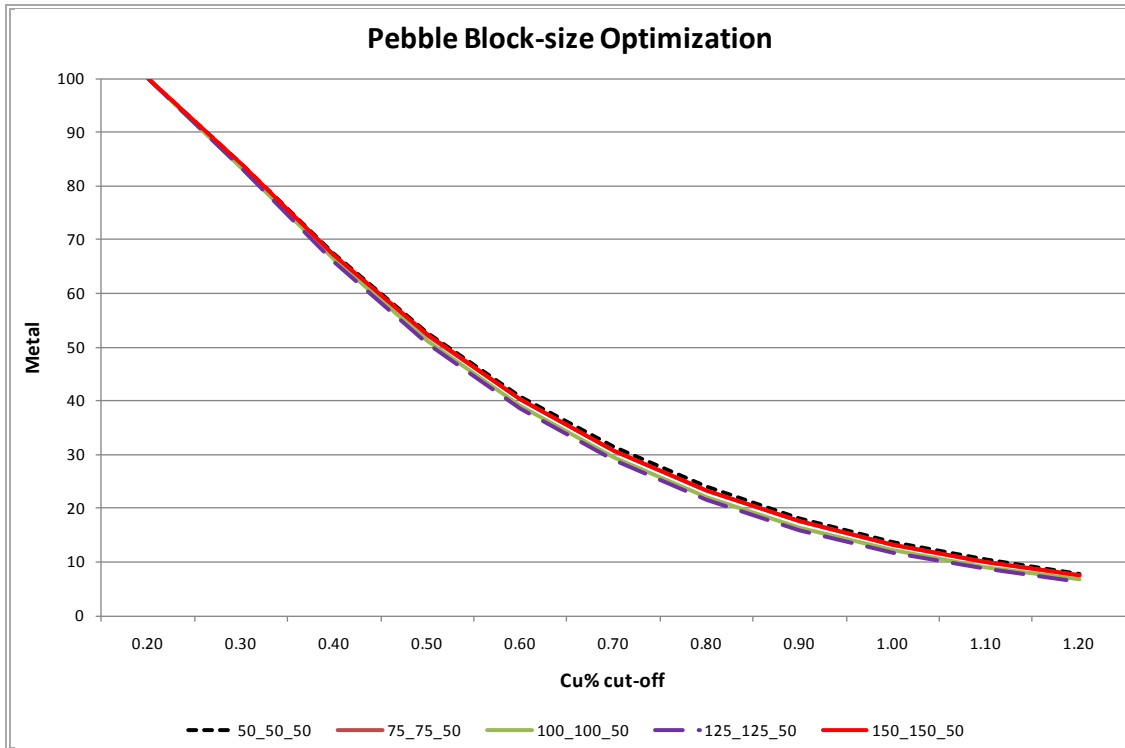
**17.12.5 BLOCK SIZE OPTIMIZATION**

A characteristic of the Pebble resource model is the tightly spaced drilling data on the west side of the deposit and wider spaced drilling to the east and at depth. The selection of block size for the model should ideally correspond to the optimal sample support. One block size for the entire deposit (75 ft x 75 ft x 50 ft) will always be compromised; if blocks are too large, resolution is lost in the east, and if blocks are too small, estimation errors are introduced in the west. For example, Figure 17.12.1 and Figure 17.12.2 demonstrate that the current block size, as calculated for the entire deposit, slightly reduces the grade (or metal). If the block size were tailored to the close-spaced drilling in the west and the less dense drilling in the east, estimation quality would improve and additional resources could be realized. Future block models may be better served by having optimal block sizes corresponding to proximal drill densities.

**Figure 17.12.1 Change in Total Cu% Grade with Respect to Change in Model Block Size and Cut-off**



**Figure 17.12.2 Change in Total copper Metal Content with Respect to Change in Model Block Size and Cut-off**



**17.12.6 QUANTITATIVE KRIGING NEIGHBOURHOOD ANALYSIS**

Wardrop investigated the application of Quantitative Kriging Neighbourhood Analysis (QKNA) on the Pebble deposit to assess if the quality of the estimate could be improved with more definitive search distances and sample selections. Large sample searches and selections can smooth Ordinary Kriged estimates, and searches designed to maximise variography ranges can introduce negative Kriging weights. Using copper as an example (Table 17.12.1), it has been demonstrated that more restricted searches could reduce the generation of negative Kriging weights and increase both the Kriging Efficiency and Slope of Regression, depending on the sample distribution (drill density). In this example, a theoretical drill density of 300 ft (X) x 300 ft (Y) x 100 ft (Z) was used. The large vertical component (Z-axis) was to minimize samples recorded from along single drill holes. Note that the negative Kriging weights, Kriging Efficiency and Slope of Regression are optimized at a relatively restrained distance (600 ft x 400 ft x 100 ft) with fewer samples required for interpolation (13). Ideally, the Pebble deposit would employ two QKNA analyses; one for the denser drilled west side of the deposit, and another for the further spaced drilling to the east. Thus additional search parameters (east and west) would be necessary for the resource estimation.



**Table 17.12.1 Search and Sample Optimization (QKNA)**

Variography Ranges													
5,000 ft	2,500 ft	1,200 ft	Search Distance			Sample Grid:		300 ft x 300 ft x 100 ft		Optimized Grid Size			
Mean Covariance	Estimation Variance	% Kriging Efficiency	XINC	YINC	ZINC	Slope (Z/Z*)	% Neg. Numbers	Max. Samples Expected	Max. Samples Returned	XINC	YINC	ZINC	Discret
0.069661	0.005043	92.76	2000 ft	1500 ft	200 ft	1.0007	7.44%	24	24	300 ft	300 ft	100 ft	5x5x2
0.069661	0.003753	94.61	1800 ft	1200 ft	200 ft	1.0146	3.30%	24	24	300 ft	300 ft	100 ft	5x5x2
0.069661	0.003753	94.61	1600 ft	1000 ft	200 ft	1.0146	3.30%	24	24	300 ft	300 ft	100 ft	5x5x2
0.069661	0.003567	94.88	1200 ft	800 ft	200 ft	1.02	3.10%	24	24	300 ft	300 ft	100 ft	5x5x2
0.069661	0.003524	94.94	1000 ft	600 ft	200 ft	1.021	3.60%	24	24	300 ft	300 ft	100 ft	5x5x2
0.069661	0.003748	94.62	1000 ft	600 ft	100 ft	1.0128	3.45%	24	24	300 ft	300 ft	100 ft	5x5x2
0.069661	0.003798	94.55	800 ft	400 ft	100 ft	1.01	1.81%	24	17	300 ft	300 ft	100 ft	5x5x2
<b>0.069661</b>	<b>0.003804</b>	<b>94.54</b>	<b>600 ft</b>	<b>400 ft</b>	<b>100 ft</b>	<b>1.0127</b>	<b>0.00%</b>	<b>24</b>	<b>13</b>	<b>300 ft</b>	<b>300 ft</b>	<b>100 ft</b>	<b>5x5x2</b>
0.069661	0.003464	95.03	600 ft	400 ft	200 ft	1.028	0.60%	24	23	300 ft	300 ft	100 ft	5x5x2
0.069661	0.00706	89.87	600 ft	400 ft	200 ft	0.9801	0.00%	24	5	400 ft	400 ft	200 ft	5x5x2
0.069661	0.005966	91.44	800 ft	800 ft	200 ft	1.035	0.40%	24	17	400 ft	400 ft	200 ft	5x5x2
0.069661	0.007703	88.94	800 ft	500 ft	150 ft	1.00008	0.00%	24	7	400 ft	400 ft	200 ft	5x5x2
0.069661	0.007619	89.06	900 ft	600 ft	150 ft	1.011	0.00%	24	9	400 ft	400 ft	200 ft	5x5x2
0.069661	0.007101	89.81	1000 ft	800 ft	150 ft	1.0211	1.24%	24	15	400 ft	400 ft	200 ft	5x5x2
0.069661	0.007619	<b>89.06</b>	<b>800 ft</b>	<b>600 ft</b>	<b>150 ft</b>	<b>1.011</b>	<b>0.00%</b>	<b>24</b>	<b>9</b>	<b>400 ft</b>	<b>400 ft</b>	<b>200 ft</b>	<b>5x5x2</b>

**Notes:**

%KE = (MC - EV) \* 100 / MC.

MC = Mean Covariance.

EV = Estimation Variance.

Rotation: Az=120 Ay=00 Ax=00.

### 17.12.7 SYN-MINERALIZATION MODEL RECONSTRUCTION

If the displacements and throw directions on the major faults within the Pebble deposit are well understood, these dislocated blocks could be wireframed (modelled) and transposed to their original positions. All samples could then more accurately be used for improved variography and block model estimation as they would be located relative to their syn-mineralization position. The number of estimation domains could possibly thus be reduced, leading to a simpler and more robust resource estimate. After interpolation, blocks and samples could then be transposed back to their current site. In this process, edge effect errors could be eliminated and more robust variography could be realized.

### 17.12.8 KRIGING EFFICIENCY AND SLOPE OF REGRESSION

Kriging Efficiency and Slope of Regression in the block model can assist in the evaluation of the quality of the Kriged estimate, and it can also be used to support more confident resource classification. To analyse the quality of subsequent block model estimates, it is suggested that Kriging Efficiency and Slope of Regression be routinely calculated in the block model.

In order to calculate Kriging Efficiency (KE%) and the slope of regression ( $Z^*/Z$ ), the F-Function (or F-Value) (F) and La Grange Multiplier (LG) will need to be included in the estimation such that:

$$Z^*Z = (BV - KRIGV + \text{abs}(LG)) / BV \text{ (for the regression of } Z^* \text{ on } Z)$$

$$KE = ((BV - KRIGV) / BV) * 100.0$$

Where:

- BV = block variance (Sill – F)
- KRIGV = Kriging Variance.

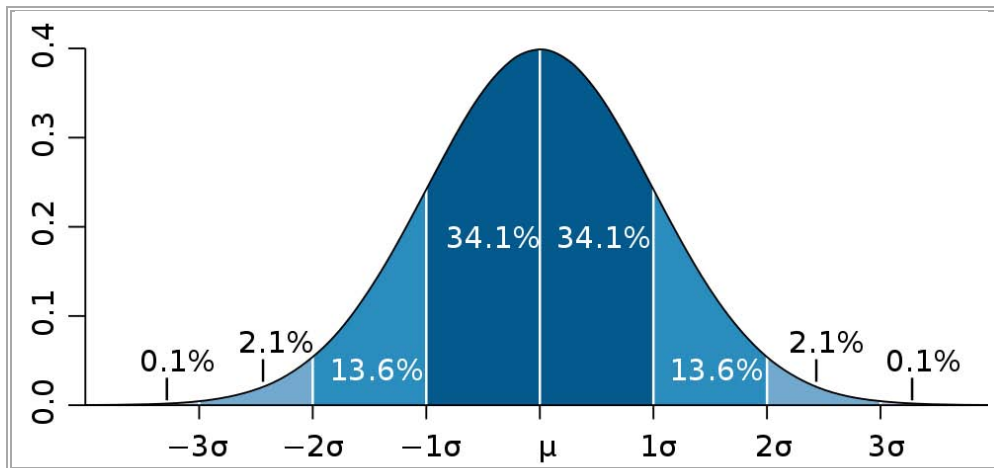
### 17.12.9 RISK ANALYSIS AND CONDITIONAL SIMULATION

It is suggested that conditional simulation be used to evaluate risk associated with the resource deposit. Conditional simulation can identify areas of high grade and high risk which may require further ground proofing. It can also be used to evaluate the effectiveness of any further infill drilling by simulating the results of a theoretical infill-drilling program and measuring their impact on reducing risk and improving resource estimation and classification.

Another application of conditional simulation is the development of confidence limits. Confidence limits can also be performed on data, which has been transformed into a normal (Gaussian) distribution by means of polynomial anamorphosis. The Gaussian distribution is depicted in Figure 17.12.3 showing the positions of the major standard deviations.

An investigation of confidence limits using this method on the Pebble deposit in its entirety has been performed using Isatis™ software. The results, shown in Table 17.12.2, indicate that the Pebble deposit has a 90% probability of achieving an average minimum grade of 0.16% Cu, and a 90% probability of achieving an average grade of 0.25% Cu. Ideally, confidence limits would be applied to specific domains or areas of interest rather than to the entire deposit.

**Figure 17.12.3 Gaussian Distribution**



The potential economic viability of the mineral resources is subject to a number of risks and will require achievement of a number of technical, economic and legal objectives, including obtaining necessary mining and construction permits, completion of pre-feasibility and final feasibility studies, preparation of all necessary engineering for open pit mining and processing facilities as well as receipt of significant additional financing to fund these objectives as well as funding mine construction. Such funding may not be available to the Northern Dynasty on acceptable terms or on any terms at all. The project requires the development of port facilities, roads and electrical generating and transmission facilities. Although Northern Dynasty believes that the State of Alaska favours the development of these facilities and there can be no assurance that these infrastructure facilities can be developed on a timely and cost-effective basis. Energy risks include the potential for significant increases in the cost of fuel and electricity. The need for compliance with extensive environmental and socio-economic rules and practices and the requirement to obtain government permitting can cause a delay or even abandonment of a mineral project. Additional information on environmental, permitting and socio-political aspects of the Pebble Project is provided in Section 18.3 and 18.4.

**Table 17.12.2 Preliminary (copper) Confidence Limits Calculations for the Pebble Deposit**

Variable (Cu)	Standard Deviation	Lower Confidence Limit	Upper Confidence Limit	Count	Minimum	Maximum	Mean	Standard Deviation	Variance
Cu OK	-	-	-	812465	-0.04	3	0.26	0.2	0.04
Gaussian Kriged Cu	1.645σ	10.0%	90.0%	812465	-2.39	2.93	0.15	0.59	0.35
Gaussian Stdev Cu	1.645σ	10.0%	90.0%	812465	0.21	0.3	0.22	0	0
Raw Backtr Cu	1.645σ	10.0%	90.0%	812465	0	1.78	0.25	0.18	0.03
Raw Minimum Cu	1.645σ	10.0%	90.0%	812465	0	1.44	0.16	0.15	0.02
Raw Maximum Cu	1.645σ	10.0%	90.0%	812465	0	2.24	0.36	0.22	0.05
Gaussian Kriged Cu	2.000σ	4.5%	95.5%	812465	-2.39	2.93	0.15	0.59	0.35
Gaussian Stdev Cu	2.000σ	4.5%	95.5%	812465	0.21	0.3	0.22	0	0
Raw Backtr Cu	2.000σ	4.5%	95.5%	812465	0	1.78	0.25	0.18	0.03
Raw Minimum Cu	2.000σ	4.5%	95.5%	812465	0	1.38	0.15	0.14	0.02
Raw Maximum Cu	2.000σ	4.5%	95.5%	812465	0	2.37	0.38	0.22	0.05

**Notes:**

Cu OK = Ordinary Kriged copper grade.

Backtr = Back-transformed from Gaussian to raw distribution. Raw data capped to 5% Cu.



## 18.0 OTHER RELEVANT DATA AND INFORMATION

---

### 18.1 MINING

---

Wardrop has conducted a technical review of the most recent open pit and underground mining data compiled by the Pebble Partnership.

To complete this review, Wardrop, has relied upon the work of other experts, whose work has been referenced throughout the following section. These experts include Knight Piésold Limited, SRK Consulting (Canada) Inc., NCL Ingeniería y Construcción S.A., Hatch Ltd., BAE, Stantec and in some instances collated reports authored by the Pebble Partnership using data from the aforementioned consultants.

Detailed pit designs for the 25-year IDC Case and the 45-year Reference Case have been developed using a combination of Whittle and Mintec mine design software. A 78-year Resource Case was optimized using a Lersch Grossman algorithm. These designs, as shown in Figure 18.1.1, incorporate extensive geotechnical investigations, and include pre-production stripping, haul road locations, and principal phases of mining.

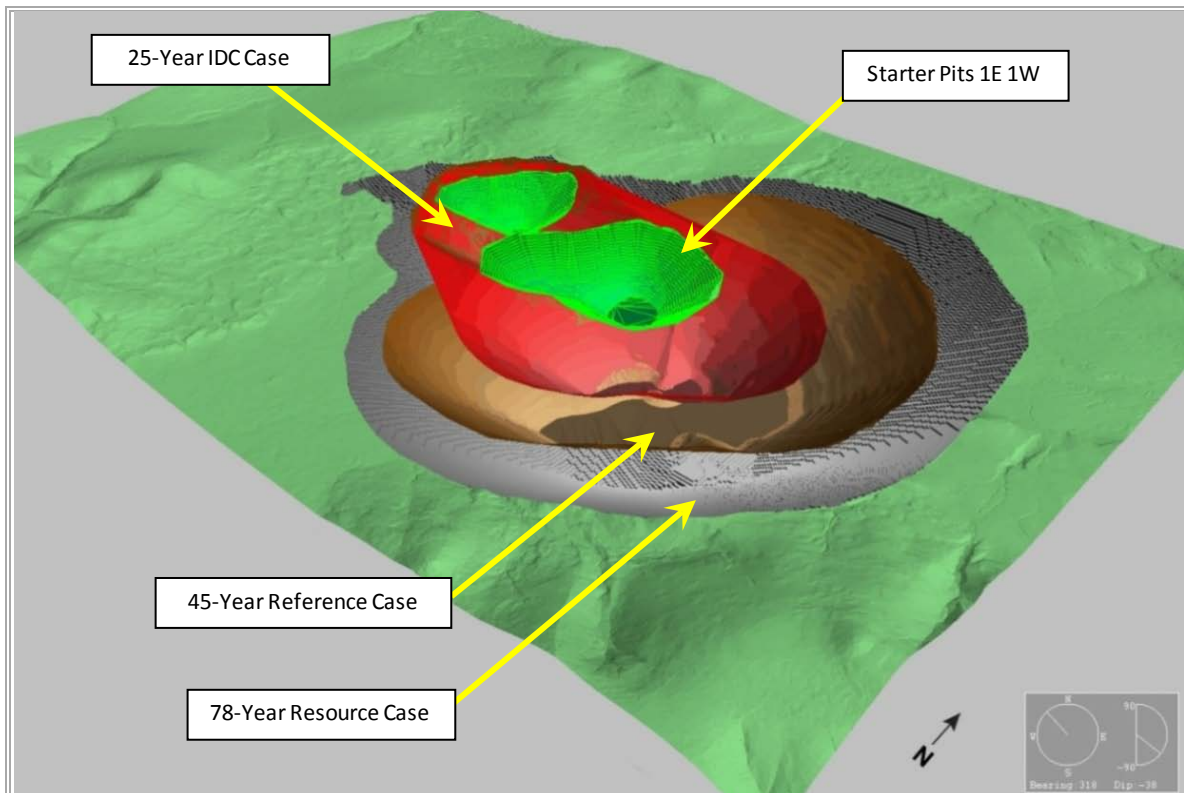
It should be noted that mine development at Pebble following the initial 25 years of production could be undertaken via underground block caving. While underground development of mineral resources in the Pebble East zone is currently considered viable, it is expected that additional investigations will be undertaken during the initial 25-year mine life to determine whether open pit or block cave development presents the best opportunity for subsequent phases of mining, based upon a broad range of factors.

Mine schedules have been developed for the life-of-mine in each case; setting out volumes of waste and ore mined, densities, tons, dilution, grades of contained metals (copper, gold, molybdenum) and material hardness. Consideration has been given to a number of aspects as described in the following paragraphs.

#### PRE-PRODUCTION STRIPPING AND START-UP

- The development schedule incorporates one year of pre-production stripping.
- The production rate at start-up has been defined by staggering the start-up of the two process lines and for each line by the appropriate McNulty curve.

**Figure 18.1.1 Pit Shells for the 25-Year IDC Case, the 45-Year Reference Case and the 78-Year Resource Case**



#### PRODUCTION RATE

- The annual production rate varies, depending on the grindability or work index of the ore.
- This was done by utilizing all grinding energy available in the comminution circuit, estimated to be 909 GWh/a, using the grindability value for each block as a variable in the resource model.
- The plant hydraulic capacity initially as defined by the SAG mills is 275,000 tons per day.
- The mine dropdown rate has been restricted to three benches per year (150 ft), except at the conclusion of a phase or pit.

#### MATERIAL HANDLING

- The semi-mobile ore crushers will initially be located immediately north of the open pit.
- These will be re-located into the pit in year 16.
- Mine haulage will utilize autonomous vehicles.
- Haulage truck requirements have been defined by haulage profiles for each case.

The open pit mine schedules for the 25-year IDC Case, 45-year Reference Case and 78-year Resource Case provide input to the financial analysis, however underground mining of the eastern portion of the Pebble deposit remains a viable development option. Ongoing studies indicate that block caving is a feasible mining method. Development schedules and production schedules, along with capital and operating costs, for a mining rate of 150,000 tons per day have been prepared.

#### 18.1.1 OPEN PIT MINING

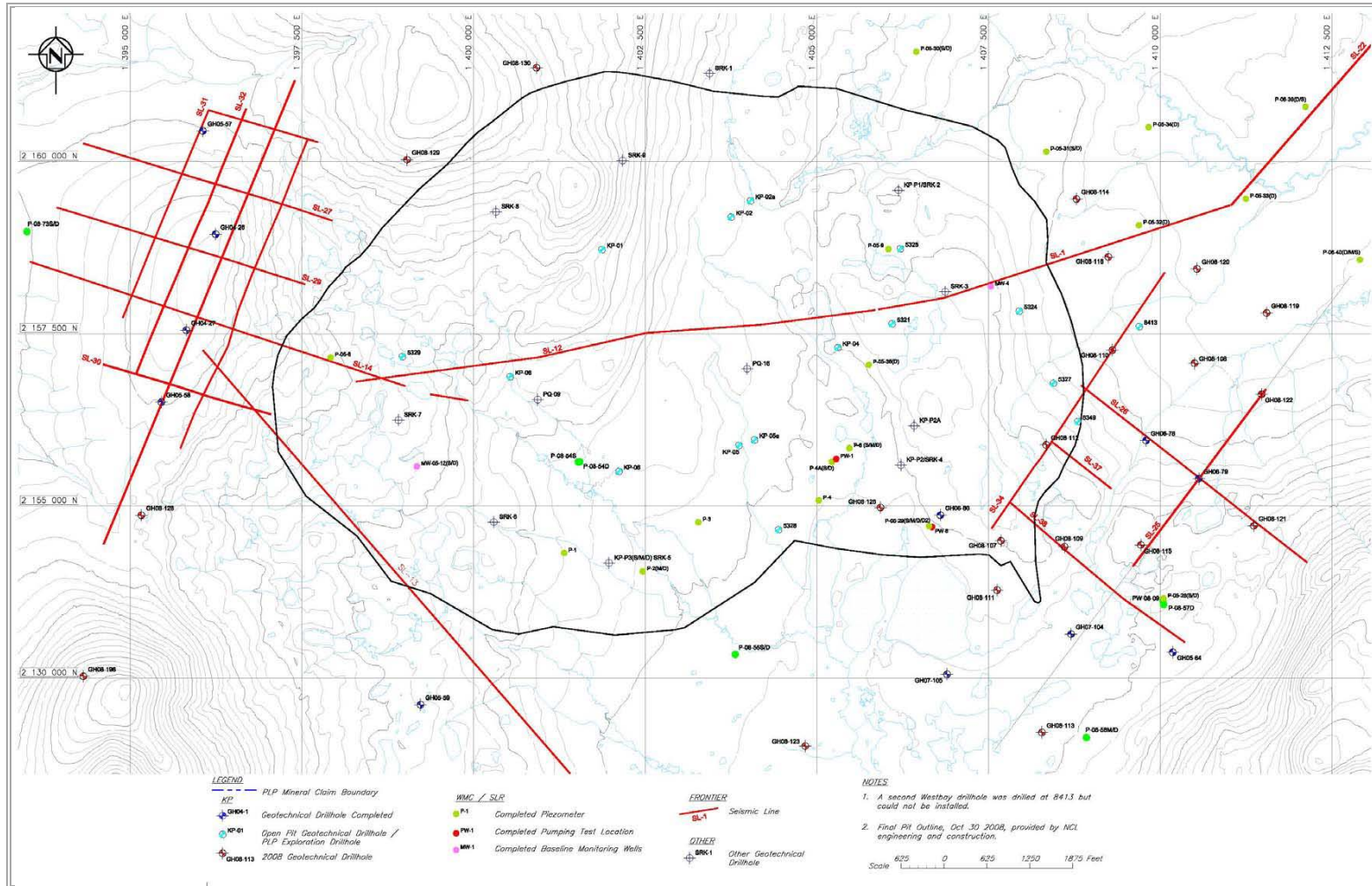
##### OPEN PIT GEOTECHNICAL

Geotechnical investigations to aid in pit designs have been conducted annually at the mine site between 2004 and 2008<sup>1,2,3,4,5</sup>. The investigations have included 215 drill holes, 320 test pits, 35 seismic lines, and an aerial photographic interpretation of the project site. The locations of geotechnical drillholes and seismic lines in the vicinity of the open pit are shown in Figure 18.1.2. The location of all test pits is shown in Figure 18.1.3.

Overburden in the area generally ranges in thickness from 0 to 150 ft and consists of glaciofluvial, glaciolacustrine and glacial drift deposits. The overall open pit outline has been roughly subdivided into western, central and eastern areas. The greatest contrast in elevation is in the western area, where it varies from 1,000 to 1,475 ft amsl. The upslope part of the western open pit area is covered with glacial drift deposits, predominantly silty sand with some gravel. The central part of the open pit area has moderate slopes and is generally characterized by well-drained glaciofluvial deposits. The eastern open pit area covers part of a wide valley, where ground elevations vary from 900 to 1,075 ft.

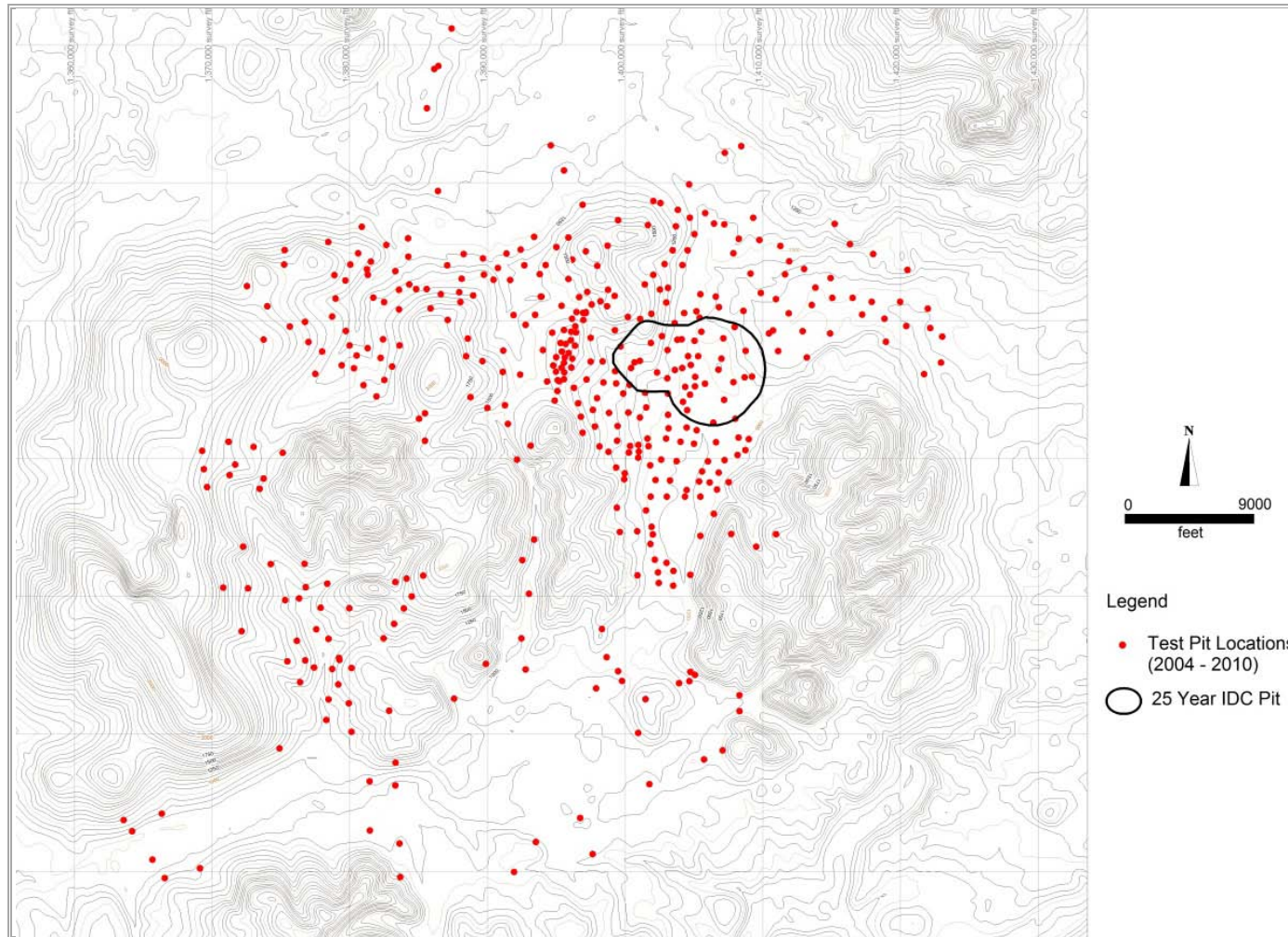
Pre-production stripping from the open pit area will provide aggregate for construction of tailings embankment facilities and for concrete production.

Figure 18.1.2 Location of All Geotechnical Drill Holes and Seismic Lines – Pit Area





**Figure 18.1.3 Location of All Test Pits**



OPEN PIT SLOPE DESIGN

The slope geometry for an open pit mine can typically be described in terms of bench geometry, inter-ramp slope angle and overall slope angle. An overall slope angle of 39° was used in the pit optimization of the Pebble Project, with bench face angles and inter-ramp angles identified in Table 18.1.1<sup>6</sup> for the areas shown in Figure 18.1.4. The Tertiary portion of the pit is shown in lighter brown to the right of green line.

Table 18.1.1 Recommended Bench Face Angle and Inter-Ramp Angle Domains

Sector	Tertiary		Cretaceous		Bench Height	Bench Width
	Bench Angle	Max Inter Ramp Angle	Bench Angle	Max Inter Ramp Angle		
SWest Dipping Face	55	44	60	47	30	10.5
West Dipping Face	55	44	55	40	30	10.5
NWest Dipping Face	60	47	55	40	30	10.5

Figure 18.1.4 45-Year Pit Showing Geotechnical Domains



## OPEN PIT OPTIMIZATION

Initial open pit optimization was completed using Whittle 4X. In this case, several staged pits were optimized, culminating in the 25-year IDC Case<sup>7</sup>. Subsequent pit phases were designed with the aid of Mintec mine design software up to the 45-year Reference Case. A Lerchs-Grossman algorithm was used to optimize the 78-year Resource Case; the 45-year pit previously designed was used as a starting point in this phase of optimization.

The parameters used for pit optimization are described in Table 18.1.2.

**Table 18.1.2 Pit Optimization Parameters**

Parameter	Unit	Value
Cu Price	US\$/lb	1.80
Au Price	US\$/oz	800
Mo Price	US\$/lb	10.00
Mining Cost (Waste & Ore)	US\$/ton	1.65
Milling Cost	US\$/ton ore	3.36
G&A Cost	US\$/ton ore	2.55
Tailings Cost	US\$/ton ore	1.65
Cu Recovery (Pebble West)	%	85.0
Payable Cu	%	98.0
Gold Recovery (Pebble West)	%	52.3
Payable Au	%	94.6
Moly Recovery (Pebble West)	%	77.8
Payable Mo	%	98.5
Cu Recovery (Pebble East)	%	89.3
Payable Cu	%	98.0
Gold Recovery (Pebble East)	%	64.6
Payable Au	%	94.6
Moly Recovery (Pebble East)	%	83.7
Payable Mo	%	98.5
Selling Cost Cu	US\$/lb	0.31
Selling Cost Au	US\$/oz	10.63
Selling Cost Mo	US\$/lb	1.50
Overall Slope Angle	degrees	39

## OPEN PIT MINE DESIGN

The central objective of the pit development strategy has been to minimize early mining costs while maximizing early returns from the open pit operation. In general, standard 100 ft high benches and 35 ft wide berms were adopted within the overall slope guidelines.

Seven pit phases were optimized for the first 25 years of mining. In general, mining will be initiated with progression through two pits: East and West. The plan will continue within both pits until the final West pit bottom is reached; thereafter, mining will continue in the East pit only. Four pit phases

have been designed for mining up to and including the 45-year Reference Case, followed by the 78-year Resource Case. Sections through the orebody showing the ultimate pits for the three production scenarios can be seen in Figure 18.1.5 and Figure 18.1.6.

Figure 18.1.5 East-West Cross Section Showing Open Pit Phase Sequence

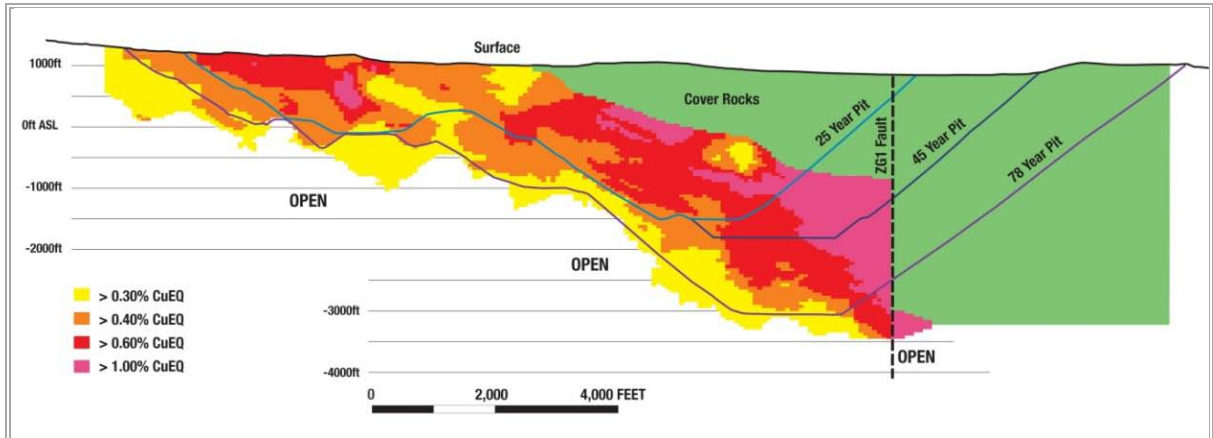
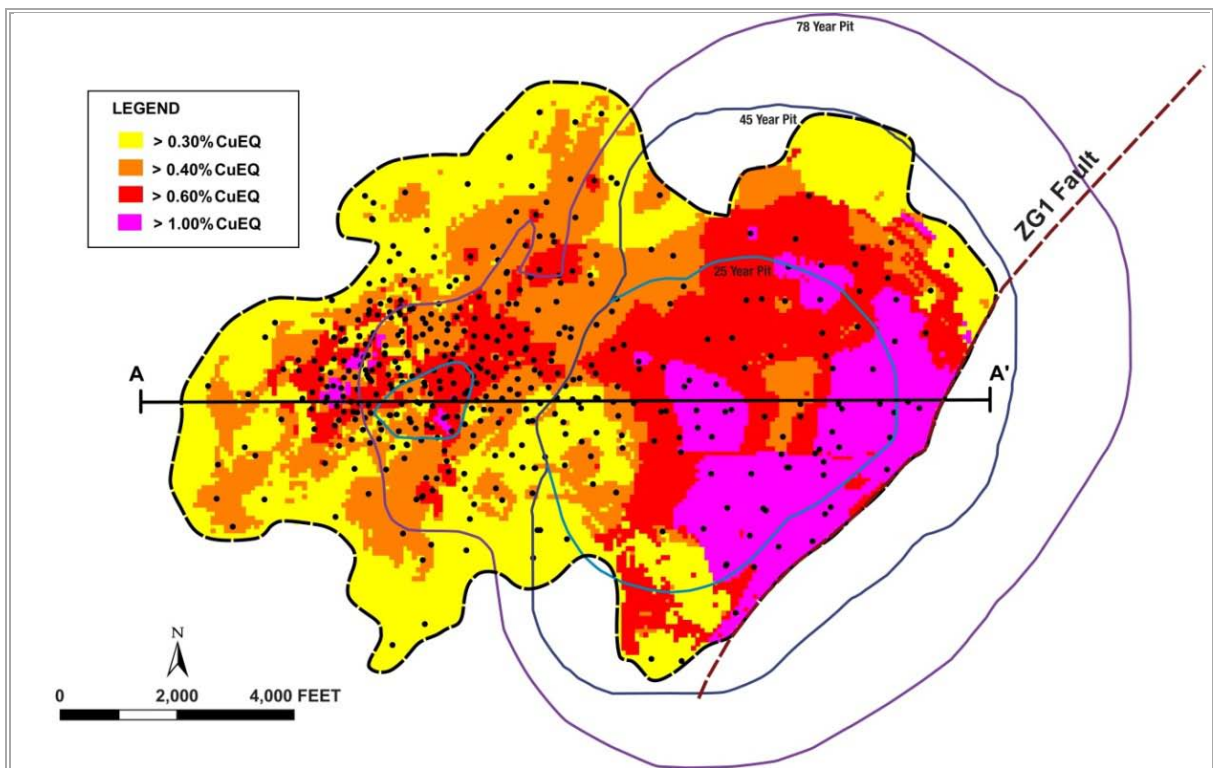


Figure 18.1.6 Open Pit Plan at 0 ft amsl – All Cases



Again it should be noted that mine development at Pebble following the initial 25 years of production could be undertaken via underground block caving. While underground development of mineral resources in the Pebble East zone is currently considered viable, it is expected that additional investigations will be undertaken during the initial 25-year mine life to determine whether open pit or block cave development presents the best opportunity for subsequent phases of mining, based upon a broad range of factors.

#### OPEN PIT MINING INVENTORY SUMMARY

The open pit mining inventory is summarized by pit phase in Table 18.1.3 and Table 18.1.4.

#### OPEN PIT OPERATION AND EQUIPMENT

Key operating assumptions for the open pit mining of the Pebble deposit are:

- 350 days of operation per year;
- two 12-hour shifts per day;
- two meal breaks per shift (one 40 minutes and one 20 minutes);
- 5 days per year assumed lost due to adverse weather conditions;
- autonomous trucking; and
- In Pit Crushing and Conveying (IPCC) starting in Year 16<sup>8</sup>.

Estimates of the total mining cost using a conventional drill, blast and truck-haul mining method with 400 ton trucks, 73 cubic yard shovels, and 12.25" drills demonstrate a correlation between increased mine life and case value.

From these operating assumptions, equipment requirements and costs have been developed in detail for the 25-year IDC Case and 45-year Reference Case. For the 78-year Resource Case, findings from previous scenarios have been modified or extrapolated to derive these requirements. For instance, an additional \$0.50/ton has been added to the mining cost to accommodate increased haulage distances; extrapolation of the relationship between strip ratio and equipment needs has been under the forecast expenditures are two such examples.

**Table 18.1.3 Incremental Open Pit Phase Volumes Based on a Cut-off of 0.2%Cu**

Phase	Ore* (ktons)	Cu (%)	Au (oz/t)	Mo (ppm)	kWh/t	OB (ktons)	Cretaceous (ktons)	Tertiary (ktons)	Strip Ratio	Total (ktons)
1e	350,024	0.354	0.012	160	12.97	59,646	137,853	210,407	1.17	757,930
1w	177,137	0.408	0.011	222	9.20	20,097	27,802	-	0.27	225,036
2e	184,152	0.404	0.014	166	9.47	32,468	63,775	313,280	2.22	593,675
2w	206,964	0.335	0.010	148	12.68	6,150	28,975	-	0.17	242,089
3e	157,033	0.386	0.012	191	9.20	25,180	58,300	287,299	2.36	527,812
3w	344,049	0.294	0.009	153	12.38	11,496	42,663	1,670	0.16	399,878
4e	385,955	0.418	0.012	237	9.15	68,495	239,574	819,584	2.92	1,513,608
<b>IDC Case (25 yr)</b>	<b>198,704</b>	<b>0.451</b>	<b>0.013</b>	<b>184</b>	<b>8.67</b>	<b>25,954</b>	<b>40,456</b>	<b>497,216</b>	<b>2.84</b>	<b>762,330</b>
9a	555,352	0.471	0.010	221	10.44	70,959	132,945	1,093,568	2.34	1,852,824
12a	468,274	0.575	0.010	223	11.16	88,150	378,026	972,058	3.07	1,906,508
20a	495,227	0.627	0.013	280	9.19	115,720	681,130	1,242,866	4.12	2,534,943
<b>Reference Case (45 yr)</b>	<b>312,877</b>	<b>0.552</b>	<b>0.012</b>	<b>300</b>	<b>9.25</b>	<b>-</b>	<b>16,051</b>	<b>129</b>	<b>0.05</b>	<b>329,057</b>
<b>Resource Case (78 yr)</b>	<b>2,692,130</b>	<b>0.465</b>	<b>0.010</b>	<b>282</b>	<b>11.02</b>	<b>95,316</b>	<b>3,324,918</b>	<b>5,955,532</b>	<b>3.84</b>	<b>12,067,896</b>
<b>Total</b>	<b>6,527,878</b>	<b>0.463</b>	<b>0.011</b>	<b>243</b>	<b>10.67</b>	<b>619,631</b>	<b>5,172,468</b>	<b>11,393,609</b>	<b>2.63</b>	<b>23,713,586</b>

\* Includes Measured, Indicated and Inferred resources.

Note:

Inferred mineral resources are considered to be too speculative to allow the application of technical and economic parameters to support mine planning and the evaluation of the economic viability of the project. There is currently no certainty that development cases incorporating Inferred mineral resources can be realized.

**Table 18.1.4 Cumulative Open Pit Phase Volumes Based on a Cut-off of 0.2%Cu**

Phase	Ore* (ktons)	Cu (%)	Au (oz/t)	Mo (ppm)	kWh/t	OB (ktons)	Cretaceous (ktons)	Tertiary (ktons)	Strip Ratio	Total (ktons)
1e	350,024	0.354	0.012	160	12.97	59,646	137,853	210,407	1.17	757,930
1w	527,161	0.372	0.012	181	11.70	79,743	165,655	210,407	0.86	982,966
2e	711,313	0.380	0.012	177	11.13	112,211	229,430	523,687	1.22	1,576,641
2w	918,277	0.370	0.012	170	11.48	118,361	258,405	523,687	0.98	1,818,730
3e	1,075,310	0.372	0.012	173	11.14	143,541	316,705	810,986	1.18	2,346,542
3w	1,419,359	0.353	0.011	168	11.44	155,037	359,368	812,656	0.93	2,746,420
4e	1,805,314	0.367	0.011	183	10.95	223,532	598,942	1,632,240	1.36	4,260,028
IDC Case (25 yr)	2,004,018	0.376	0.011	183	10.73	249,486	639,398	2,129,456	1.51	5,022,358
9a	2,559,370	0.396	0.011	191	10.66	320,445	772,343	3,223,024	1.69	6,875,182
12a	3,027,644	0.424	0.011	196	10.74	408,595	1,150,369	4,195,082	1.90	8,781,690
20a	3,522,871	0.452	0.011	208	10.52	524,315	1,831,499	5,437,948	2.21	11,316,633
Reference Case (45 yr)	3,835,748	0.461	0.011	216	10.42	524,315	1,847,550	5,438,077	2.04	11,645,690
Resource Case (78 yr)	6,527,878	0.462	0.011	243	10.67	619,631	5,172,468	11,393,609	2.63	23,713,586

\* Includes Measured, Indicated and Inferred resources.

Note:

Inferred mineral resources are considered to be too speculative to allow the application of technical and economic parameters to support mine planning and the evaluation of the economic viability of the project. There is currently no certainty that development cases incorporating Inferred mineral resources can be realized.

## WASTE STOCKPILES AND TRUCK HAULAGE

Autonomous trucking improvement assumptions for performance and labour were taken from information available in the public domain and based on an estimate of future technology benefits being attained. Table 18.1.5 describes the criteria used.

**Table 18.1.5 Assumed Autonomous Trucking Improvements**

Performance Area	Comment
Fuel consumption (USgal/Op h)	Operating the vehicle in the specification range is estimated to improve total fuel consumption by 8%
Tire life (h)	Operating the vehicle in the specification range is estimated to improve tire life by 50%
Maintenance (\$/op h)	Operating the vehicle in the specification range is estimated to improve maintenance cost per operating hour by 8%
Utilisation (%)	The driverless truck is estimated to improve utilization from 83% to 88%
Availability (%)	Operating the vehicle in the specification range is estimated to improve availability from 84% to 88%
Labour complement	The driverless truck is estimated to reduce truck the operator complement by 75%

Waste stockpiles will be located within 1,000 to 1,500 ft of the rim of the 78-year pit. The exceptions will be to the southeast due to high topography and to the northwest where operational infrastructure is located. Haul roads for ore will exit from the north rim of the pit, whereas haul roads for the waste will exit from the north, east and south sides of the pit. The western portion of the south dump will backfill the Pebble West open pit. The stockpiles will be constructed as close as is practicable to the open pits to reduce the length of flat haul from the pit rim to the start of the stockpile ramp. An approximate configuration of the dumps and stockpile can be seen in Figure 18.1.7.

Stockpile tonnage has been calculated from the contained volume of the stockpile using an average density of 15 ft<sup>3</sup>/ton.

Truck haulage profiles have been broken up into sections of uphill, downhill and flat haulage and generated for ore, mineralized waste and non-mineralized waste material types. Uphill is the summation of those ramp distances at a positive slope of 8%, downhill for negative ramp slope distances of -8%, and flat haulage at no ramp slope, such as between the pit rim and the primary crusher. The profiles have been given in one direction only as the return trip is just the opposite of the loaded haul in the calculation of the haulage cycle from the profiles. Table 18.1.6 lists the speeds that were assigned to each length of section to determine total cycle time as well as assumed fuel consumption.

The ramp hauls out of the pit and up the side of the waste stockpiles have been calculated annually. For each year in the production schedule, the average depth of mining has been stipulated and the average ramp haul length to pit-rim calculated. Likewise, accumulated waste tonnage determined the height of the waste stockpiles and allows the calculation of stockpile ramp haulage distance.

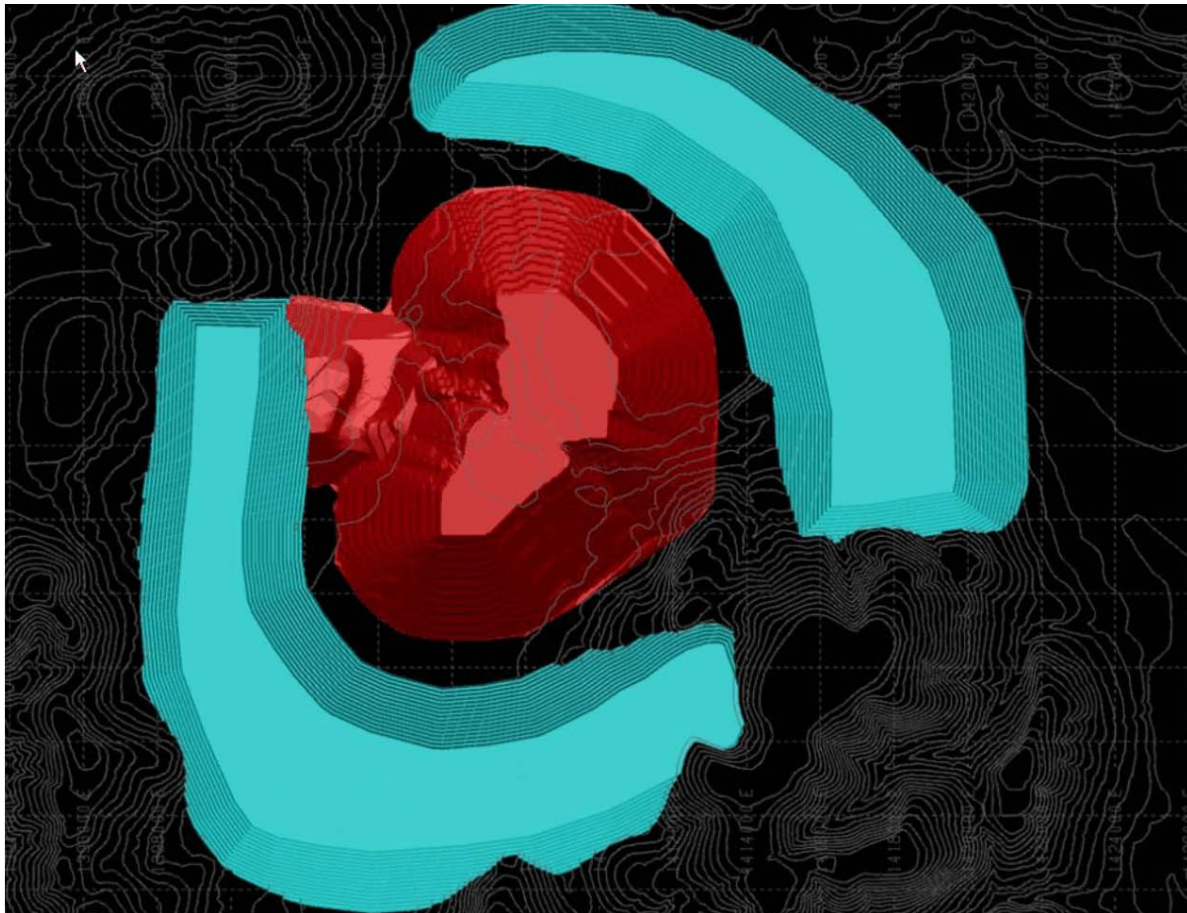


**Table 18.1.6 Haulage Profile Speeds and Fuel Consumption by Section**

Section	km/h	gal/h
Upwards Empty	25	2.92
Upwards Loaded	12	7.09
Downwards Empty	30	0.04
Downwards Loaded	25	0.05
Horizontal Empty	40	1.22
Horizontal Loaded	35	1.60

Haulage profiles have been calculated and used for the truck hour calculations in the open pit costing section of the mining report for the 25-year IDC Case and 45-year Reference Case. Haulage profiles have not been calculated in the 78-year Resource Case, but an additional mining cost of \$0.50/ton has been applied in the financial model to accommodate greater haulage distances.

**Figure 18.1.7 Approximate Waste Dump Configuration**



## DRILLING, BLASTING AND LOADING

A drilling pattern of 21.3 x 32.8 ft has been adopted. The resulting estimates of annual production capacity are shown in Table 18.1.7.

Explosives consumption estimates, including requirements for trim blasting and pre-splitting, are shown in Table 18.1.8.

The production performance of all loading units – including 73 cubic yard rope shovels, 53 cubic yard hydraulic shovels and front-end loaders – are shown in Table 18.1.9.

**Table 18.1.7 Sample Drill Productivity Calculations**

Item	Units	Electric	Diesel
Diameter	in	12 ¼	12 ¼
Specific Drilling	ft <sup>3</sup> /ft	0.3	0.3
Rock Density	lb/ft <sup>3</sup>	168.53	168.53
Drilling Performance	lb/ft	45	45
Drilling Velocity (Instantaneous)	ft/h	98.4	82.0
<b>Operational Factor</b>	%	80.00%	80.0%
Drilling Velocity (Operational)	ft/h	78.7	65.6
Production per Hour	ton/Op h	3,560	2,967
<b>Availability</b>	%	84.0%	0.84
<b>Utilization</b>	%	80.0%	80.0%
Hours per Shift	h	12	12
Shifts per Day		2	2
Days per Year	day	350	350
Annual Production	K ton	20,097	16,748.0

**Table 18.1.8 Sample Basic Blasting Calculations**

Item	Units	Basic Blasting Calculations	Sample Trim Basic Calculations	Sample Pre-splitting Calculations
Diameter	in	12 ¼	12 ¼	6 ½
Diameter	mm			
Diameter Explosive Load	in	12.25	12.25	6.50
Diameter Explosive Load	ft	1.020	1.020	0.541
Rock Density	lb/ft <sup>3</sup>	168.53	168.53	168.53
Explosive Density	lb/ft <sup>3</sup>	49.94	49.94	49.94
Bench Height	ft	50	50	50.0
Burden	ft	21.3	360.9	360.9
Spacing	ft	32.8	18	8.2
Subdrill	ft	6.6	0.0	0.0
Length of Hole	ft	56.6	50.0	50.0

*Table continues...*

...Table 18.1.8 (cont'd)

Item	Units	Basic Blasting Calculations	Sample Trim Basic Calculations	Sample Pre-splitting Calculations
Stem Length	ft	23	23.0	23.0
Length of Explosive	ft	33.6	27.0	27.0
Explosive per tonnes	lb/ft	40.837	40.837	11.498
Explosive per Hole	ton	0.686	0.552	0.1555
Volume of Hole	ft <sup>3</sup>	34,982	325,600	148,000
Tonnes / Hole	ton	2,948	27,437	12,472
Powder Factor	lb/ton	0.465	0.0402	0.0249

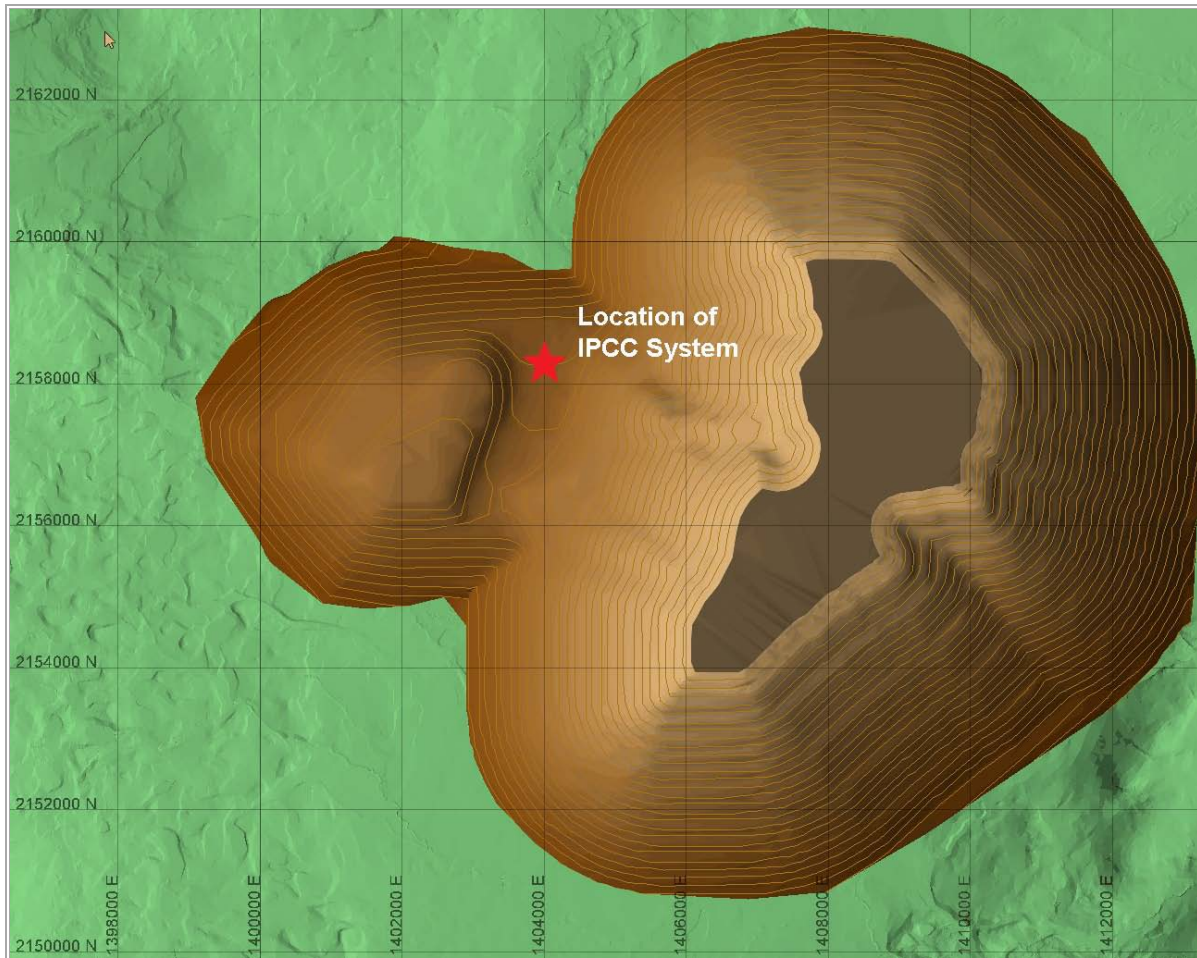
**Table 18.1.9 Sample Loading Productivity Calculations**

Item	Units	Electric Shovel	Hydraulic Shovel	FEL
Bucket Capacity	yd <sup>3</sup>	73.0	53	53.0
Bucket Capacity	m <sup>3</sup>	55.8	40.5	40.5
Fill Factor	%	85	85	85.0
Bucket Load Wet	ton	100.4	72.9	72.9
Loading Cycle	min	0.58	0.55	0.80
No. Buckets		3.98	5.49	5.49
Truck Capacity	ton	400	400	400
No. of Passes		4	6	6
Loading Time	min	2.32	3.30	4.80
Truck Waiting	min	0.50	0.50	0.50
Spotting	min	0.50	0.50	0.50
Tonnes per Hour Effective	ton/h	7,229	5,581	4,138
<b>Operational Factor</b>	%	80.0	80.0	80.0
Tonnes per Hour Operation	ton/Op h	5,783	4,465	3,310
<b>Availability</b>	%	85.0	85.0	82.0
<b>Utilization</b>	%	80.0	80.0	80.0
Hours per Shift	h	12.0%	12.0%	12.0%
Shifts per Day		2.0%	2.0%	2.0%
Days per Year	d	350.0%	350.0%	350.0%
Annual Production	k ton/yr	33,033	25,505	18,241

**IN PIT CRUSHING AND CONVEYING (IPCC)**

In year 16 of the open pit mine life, a bench on 400 ft elevation provides an opportunity for the installation of an IPCC station <sup>8</sup>. Figure 18.1.8 highlights the position on the 400 ft elevation.

**Figure 18.1.8 Position of IPCC at 400 ft Elevation**



### EQUIPMENT REQUIREMENTS

The equipment requirements for the 25-year IDC Case and the 45-year Reference Case have been derived. The relationship between strip ratio and equipment expenditures over time up to 45 years was used to forecast equipment costs for the 78-year Resource Case.

#### Main Equipment

The main equipment requirement by year, for the 48-year Reference Case is summarized in Table 18.1.10.

**Table 18.1.10 Main Equipment Requirements**

Item	Mine Life Horizons (Year)									
	0	5	10	15	20	25	30	35	40	45
Drills 12.25"	5	8	9	16	16	17	19	19	11	6
Shovels 73 yd <sup>3</sup>	2	3	4	6	7	7	8	8	4	2
Hydraulic Shovels 53 yd <sup>3</sup>	1	2	2	3	3	3	2	2	1	1
53 yd <sup>3</sup> Wheel Loader	1	2	2	3	3	3	2	2	1	1
Autonomous Trucks 400 ton	11	21	30	82	88	104	130	158	84	48

The mining fleet will increase to match the stripping ratio requirement to deliver scheduled ore to the metallurgical plant in alignment with each of these development cases. The 45-year Reference Case has a daily mining rate of approximately 1,000 ktons for the period year 25 to year 35. The value in applying the IPCC technology to reduce the haul truck fleet in later years is apparent.

*Ancillary Equipment*

The selection of ancillary equipment takes into account the size and type of the main fleet for loading and hauling, the geometry and size of the pit, and the number of roads and waste dumps that will operate at the same time. It reflects experience at operations of similar size and also considers the specific characteristics of the Pebble Project – such as, remote location, long haul distances, high dumps, strong winds and winter snowfall.

The ancillary equipment required for the 45-year Reference Case is summarized in Table 18.1.11.

**Table 18.1.11 Ancillary Equipment Requirement**

Item	Mine Life Horizons (Year)									
	0	5	10	15	20	25	30	35	40	45
Dozer	6	8	9	14	14	14	16	16	9	7
Wheel Dozer	3	4	5	8	8	8	9	9	5	4
Grader	1	2	3	8	9	11	13	15	9	6
Water Truck	3	4	5	9	9	10	10	10	6	3

*Support Equipment*

Support equipment includes a 6½-inch drill for secondary blasting and pre-drilling, and general equipment for maintenance of the major equipment fleet, as shown in Table 18.1.12.

*Equipment Life*

Equipment life for the major mining units has been defined in years of operation, based on information from other operations that use similar equipment and on information provided by suppliers. Replacement operating years are shown in Table 18.1.13.

**Table 18.1.12 Support Equipment Requirements**

Equipment	# Required
Secondary Drill	4
Backhoe Excavator	2
Service Truck	3
Low Bed Truck	2
Service Wheel Loader	2
Fuel Truck	2
Mobile Crane	3
Tire Handler	2
Cable Reel	2
Motivator	1

Equipment	# Required
Pumps	6
Dispatch & Radio	1
Pickup Trucks	25
Snow Cat	4
Ligthing Plants	10
Survey and Radar	1
Hardware & Software	1
Ambulance	1
Fire Truck	1

**Table 18.1.13 Estimated Life of Equipment**

Equipment	Replacement (years)
<b>Primary Equipment</b>	
12¼" Electric & Diesel	13
Shovel	14
Wheel Loader	7
Hydraulic Shovel	14
Haul Truck	12
<b>Ancilliary Equipment</b>	
Bulldozers	7
Wheeldozer	7
Graders	7
Water Trucks	7
Service Wheel Loader	7
<b>Support Equipment</b>	
Secondary Drill	10
Backhoe Excavator	10
Service Truck	5

Equipment	Replacement (years)
Low-Bed Truck	5
Service Wheel Loader	10
Fuel Truck	5
Mobile Crane	10
Tire Handler	10
Cable Reeler	10
Motivator	10
Pumps	5
Dispatch & Radio	10
Pick-Up Trucks	5
Snow Cat	10
Lighting Plants	5
Surveying and Radar	10
Hardware & Software	10
Ambulance	5
Fire Truck	10

### *Equipment Schedule of Acquisition*

Equipment purchase is driven by the production schedule, equipment productivity and equipment operating life cycle. The estimate has been prepared using a just-in-time approach.

OPEN PIT MINING COSTS

*Capital Cost Estimate*

The capital cost estimate for mining equipment is based on vendor quotes as summarized in Table 18.1.14. Additional allowances have been made for special modifications (e.g. Arctic package), transport and erection at site. Freight cost from Seattle to site has been estimated and captured in the G&A section on a dollars per ton basis.

**Table 18.1.14 Estimated Mine Equipment Capital Costs**

Equipment	Capital Cost (US\$)
<b>Primary Equipment</b>	
12¼" Electric & Diesel	6,012,000
Shovel	29,205,000
Wheel Loader	7,650,000
Hydraulic Shovel	20,157,000
Haul Truck	5,795,000
<b>Ancillary Equipment</b>	
Bulldozers	1,898,000
Wheeldozer	1,973,000
Graders	786,000
Water Trucks	2,952,000
Service Wheel Loader	
<b>Support Equipment</b>	
Secondary Drill	950,000
Backhoe Excavator	1,250,000
Service Truck	360,000
Low-Bed Truck	2,000,000
Service Wheel Loader	550,000
Fuel Truck	500,000
Mobile Crane	700,000
Tire Handler	400,000
Cable Reeler	300,000
Motivator	900,000
Pumps	60,000
Dispatch & Radio	6,000,000
Pick-Up Trucks	50,000
Snow Cat	900,000
Lighting Plants	50,000
Surveying and Radar	1,000,000
Hardware & Software	1,000,000
Ambulance	200,000
Fire Truck	350,000

Additional capital for autonomous haul truck conversion has not been included. Currently, autonomous haul trucks are produced and sold with the flexibility to be driven by an operator. The unquantified savings from the expected removal of this capability are assumed to offset any additional capital required.

Spare parts initial stock for all equipment is included in the capital estimate and calculated by applying an 8% value factor to the main and major ancillary equipment purchase value for the first three years in the mining plan.

The capital expenditure cash flow for each case is estimated for each year of the mine life. Estimated values are real and undiscounted. Table 18.1.15 summarizes the total estimated capital (initial and sustaining) over the life-of-mine for each development case. The initial capital for mining equipment is \$247 million excluding indirect costs and owners costs.

**Table 18.1.15 Life-of-mine Capital Estimate for Mine Equipment**

LOM (year)	Operation	LOM Capital Expenditure Estimate (\$ millions)
25	Conventional Drill and Blast, and Autonomous-Haul, and IPCC Of Ore	1,968
45	Conventional Drill and Blast, and Autonomous-Haul, and IPCC Of Ore	3,206
78	Conventional Drill and Blast, and Autonomous-Haul, and IPCC Of Ore	7,145

\* Capital estimates do not include the capital and sustaining capital of the IPCC system <sup>9</sup>.

### *Operating Cost Estimate*

Operating cost estimates have been prepared in detail for the 25-year IDC Case and the 45-year Reference Case. For the 78-year Development Case, two approaches have been taken to derive operation costs: where costs remain fixed, average values derived from the 45-year case have been used or escalated based on cost trends; where costs are clearly a function of a value, such as strip ratio, this relationship was used.

A moisture content of 3% has been used to calculate wet tons for the mining cost estimate. Mining costs per ton have been expressed as costs per dry ton. Operating costs have been estimated in the categories outlined in Table 18.1.6 using specific performance criteria for working equipment.

### *Labour Estimate*

The machine operator and maintenance staff complement reflects employees on payroll (as opposed to on site) and aligns with a two-week-on/one-week-off shift schedule. The duration of each shift is 12 hours. The number of employees required to support a position is approximated at 3.12 and the ratio of operator labour complement to maintenance labour complement is set at 1.5:1.

Table 18.1.17 shows the management labour complement.

Table 18.1.18 shows the mining operator and maintenance labour on payroll for the 45-year Reference Case.



**Table 18.1.16 Operating Cost Categories**

Mining Category	Cost Unit	Comment
Drilling	\$/dry ton	Fuel, energy, consumables, spares and components applied to operating hours
Blasting	\$/dry ton	Consumables applied to tons blasted in mine plan
Loading	\$/dry ton	Fuel, energy, consumables, spares and components applied to operating hours
Transport	\$/dry ton	Fuel, consumables, spares and components applied to operating hours
Ancillary Equipment	\$/dry ton	Fuel, consumables, spares and components applied to operating hours
Other Support Equipment	\$/dry ton	Estimated total cost per operating hour
Dewatering	\$/dry ton	Factor of \$0.05 per wet ton
Re-handling	\$/dry ton	5% of ore expected to be re-handled and \$0.05 per wet ton applied
Labour	\$/dry ton	Management persons per unit required to meet production

**Table 18.1.17 Operational Management Complement**

Position	# of Employees
Mine Management	1
Technical Services	39
Operations	19
Maintenance	17
<b>Total</b>	<b>76</b>

**Table 18.1.18 Operator and Maintenance Staff on Payroll**

	Yr 0	Yr 5	Yr 10	Yr 15	Yr 20	Yr 25	Yr 30	Yr 35	Yr 40	Yr 45
Operators	61	93	154	239	248	269	294	323	167	106
Maintenance	62	95	159	288	299	332	378	438	230	147
<b>Total</b>	<b>123</b>	<b>188</b>	<b>313</b>	<b>527</b>	<b>547</b>	<b>601</b>	<b>672</b>	<b>761</b>	<b>397</b>	<b>253</b>

\* The labour required to operate the IPCC system is not included in this estimate.

*Summary*

Mining operating costs are shown in Table 18.1.19. Estimated values are real and undiscounted. Operating costs include costs incurred during pre-production.

Table 18.1.20 summarizes the mining cost per dry ton for the 45-year Reference Case. Estimated costs are real and undiscounted.

**Table 18.1.19 Total Mining Operating Cost for 45-Year Reference Case**

Mining Cost	LOM 45 Years Autonomous Trucks & IPCC	
	\$M	\$/ton
Drilling	921	0.08
Blasting	1,992	0.17
Loading	1,552	0.13
Transport	7,865	0.68
Ancillary Equipment	1,470	0.13
Other Support Equipment	195	0.02
Dewatering	596	0.05
Rehandling	97	0.01
Labour	2,858	0.25
<b>Total</b>	<b>17,547</b>	<b>1.52</b>

**Table 18.1.20 Total Mining Operating Cost per Time Horizon**

Case	Unit	Mine Life Horizons (Year)										LOM Avg
		0	5	10	15	20	25	30	35	40	45	
Autonomous & IPCC*	\$/ton	1.22	1.13	1.11	1.42	1.38	1.44	1.60	1.84	1.98	2.13	1.52

\* Mining costs do not include the operating cost per ton of ore for IPCC system <sup>9</sup>.

### 18.1.2 UNDERGROUND MINE PLANNING <sup>13</sup>

Further studies are required to determine the optimal long-term development path for Pebble. However, current analysis demonstrates that underground mining using block caving techniques remains a viable option for certain parts of the Pebble deposit.

Underground production schedules have been prepared using a mining rate of 150,000 tons per day. Grade and production rate have been optimized by combining individual mining block schedules, and a life-of-mine production schedule has been prepared which maximizes grade and production rate sustainability.

Conceptual mine designs have been developed along with a high-level pre-production development and construction schedule so that pre-production capital, sustaining capital, and operating costs can be estimated.

#### MINE DESIGN

Design criteria employed in the underground block cave design utilize a drawpoint spacing of 55 ft in an offset herringbone pattern on the extraction level. All extraction levels for the 11 mining blocks are placed in ground with a Rock Mass Rating (RMR) greater than 50<sup>10,11,12</sup>. The current design calls for an extraction level at:

- -2400 ft elevation for Blocks N1 through N7 and N9;

- -2450 ft for Blocks S1 and S2; and
- -2100 ft for Block N8.

Mining blocks are approximately 855 ft wide with a maximum underground production rate of 50,000 tons per day in each block. A total of 150,000 tons per day is obtained from multiple mining blocks. Load Haul Dump (LHD) units working on the extraction level direct tip into jaw crushers with conveyors transporting the crushed ore to the production shafts.

A conceptual mining block layout is shown in Figure 18.1.9. The extraction levels are at different elevations as shown in the cross-section along A-A' (Figure 18.1.10). A schematic of the mine design is presented in Figure 18.1.11.

**Figure 18.1.9 Conceptual Underground Mining Block Layout**

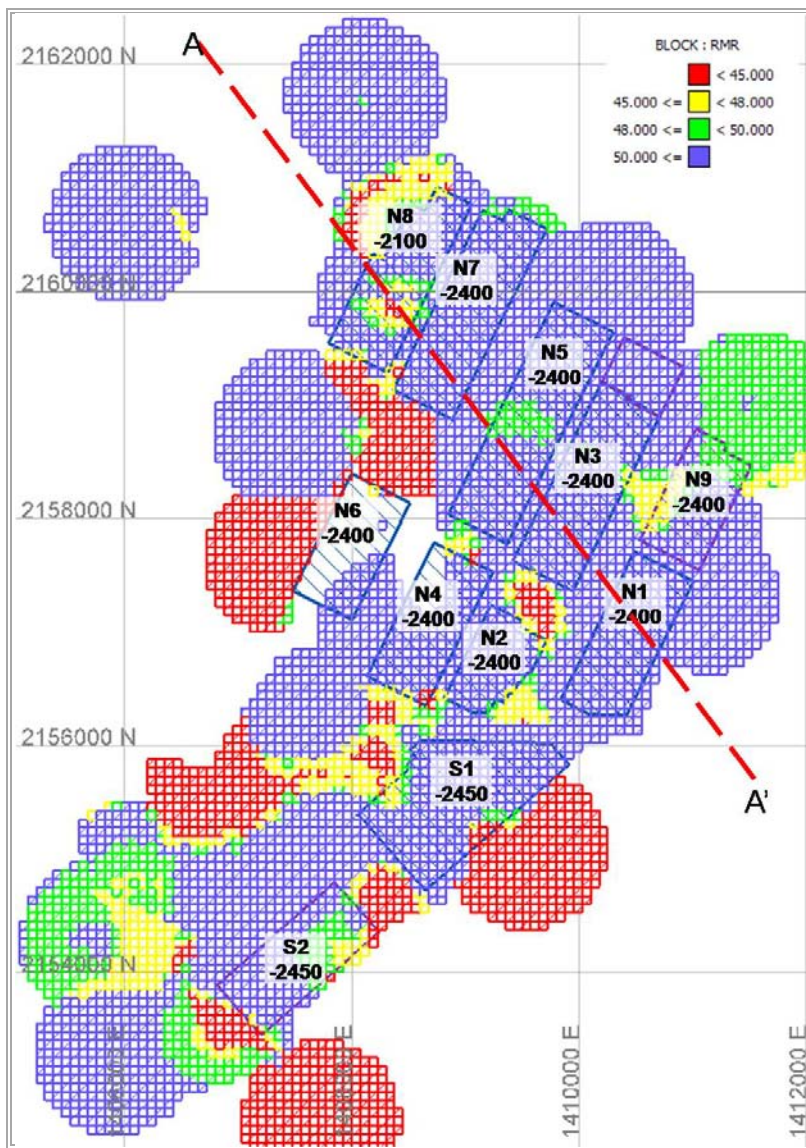
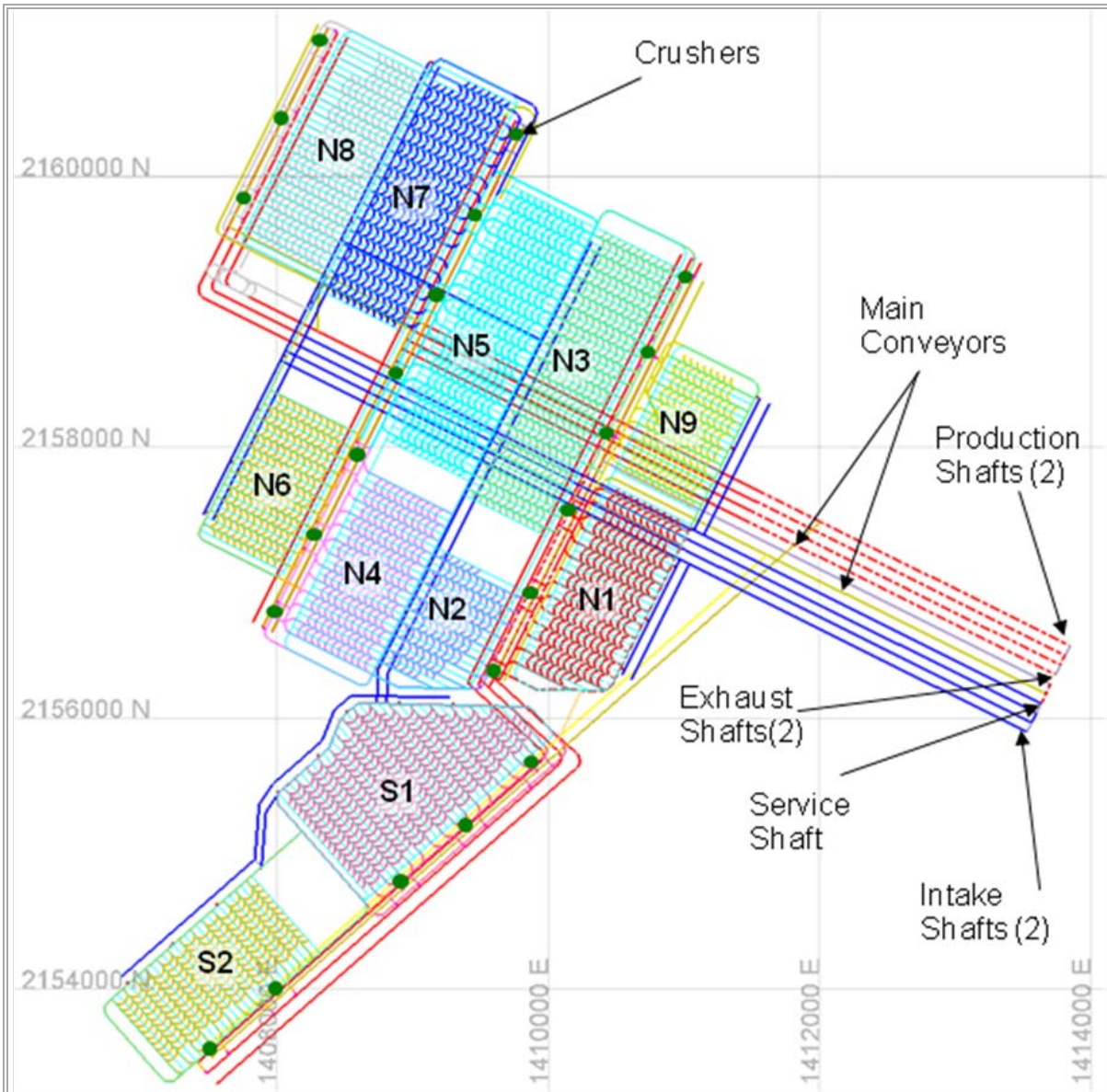


Figure 18.1.10 Section A-A' through the Conceptual Mine Block Layout



Figure 18.1.11 Underground Mine Design Schematic



## SURFACE FACILITIES AND MINE ACCESS

The main surface facilities are located at the service shaft site. All shafts are located to the east of the mining area. The mine design uses four shafts including: two 33 ft diameter production shafts (60,000 tons per day); one 33 ft diameter service shaft (30,000 tons per day); two 30 ft diameter intake shafts; and two 31.5 ft diameter exhaust shafts.

Surface facilities and infrastructure at the shaft sites include a shaft headframe and hoist room, office and dry, fuel storage, warehouse, temporary electrical generation plant, maintenance shop, service water, fire water and sewage distribution systems.

During the pre-production period, the underground mine will be developed via the service shaft and an intake shaft. A 33 ft-diameter concrete-lined service shaft is located 3,000 ft east of the underground block caving area outside of a 55 degree fracture initiation angle plus 300 ft continuous subsidence zone. The shaft will be 3,560 ft deep, with the main station located at -2260 ft elevation. A temporary skip-loading lip-pocket arrangement will be installed on the main station to handle development muck during pre-production. The hoisting system in the service shaft will be changed over to production hoisting with a capacity of 30,000 tons per day.

The service shaft is the primary means to provide heated fresh air to the underground during the pre-production phase. Once the rock handling system is operational, the service shaft is equipped with steel guides and a service cage. Distribution slick lines in the service shaft will be used to deliver concrete and shotcrete to the main station. Transportation from the main station to the footprint is via personnel carriers for the workforce, flatbed trucks for materials and transmixers for shotcrete and concrete.

## EXTRACTION LEVEL DEVELOPMENT

An offset herringbone layout with 55 ft drawpoint spacing will be used as the basis for the extraction level design. The drawpoint design can be seen in Figure 18.1.12. The footprint development includes the extraction and undercut levels. The footprint development for each mining block is comprised of two levels: an undercut level and an extraction level. As a means of minimizing development requirements, the crushers are shared by adjacent mining blocks.

Crushers are located along the extraction level perimeter drift of each mining block. Each crusher is connected to six panel drifts. Exhaust raises are located along either side of a crusher to pull the used air down to the dedicated exhaust drift. Intake raises are located on the opposite end of the panel drifts, offset from the exhaust raises. This allows fresh air to sweep across the panel drifts to the exhaust raises. An illustration of a typical extraction level arrangement is presented in Figure 18.1.13.

Figure 18.1.12 Typical Drawpoint Design

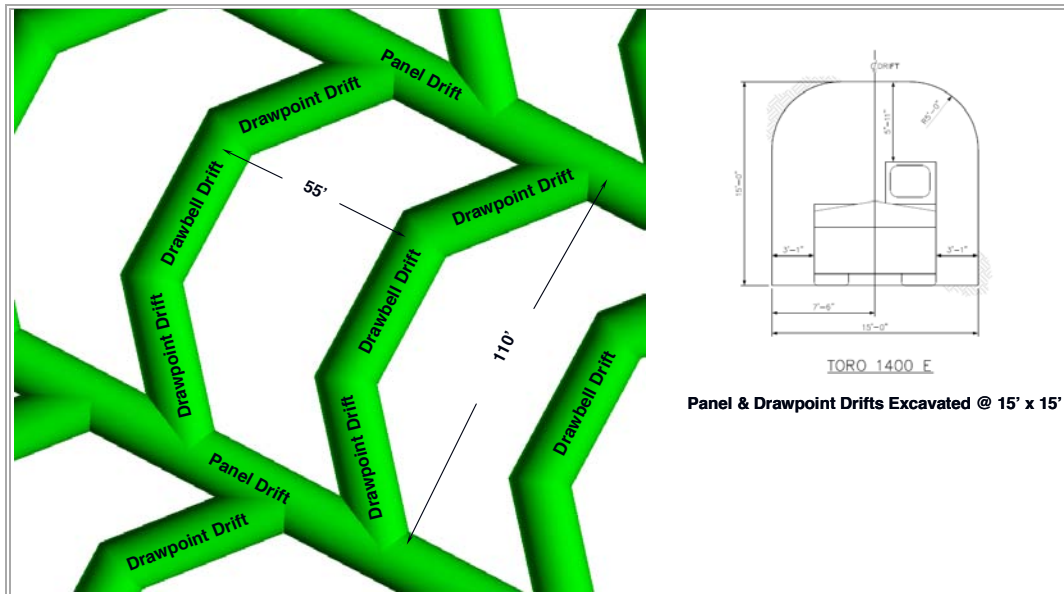
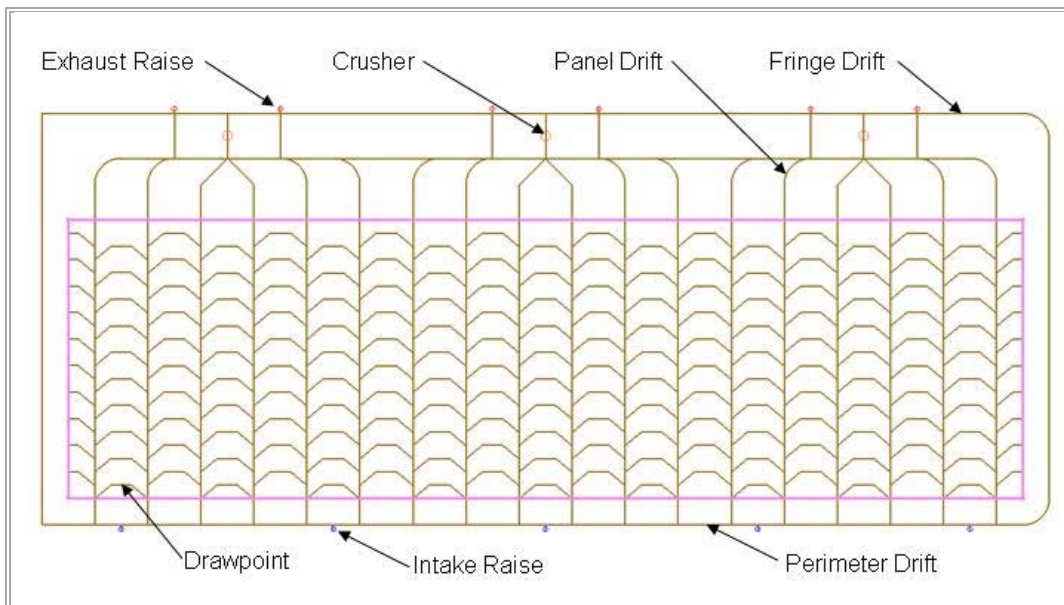


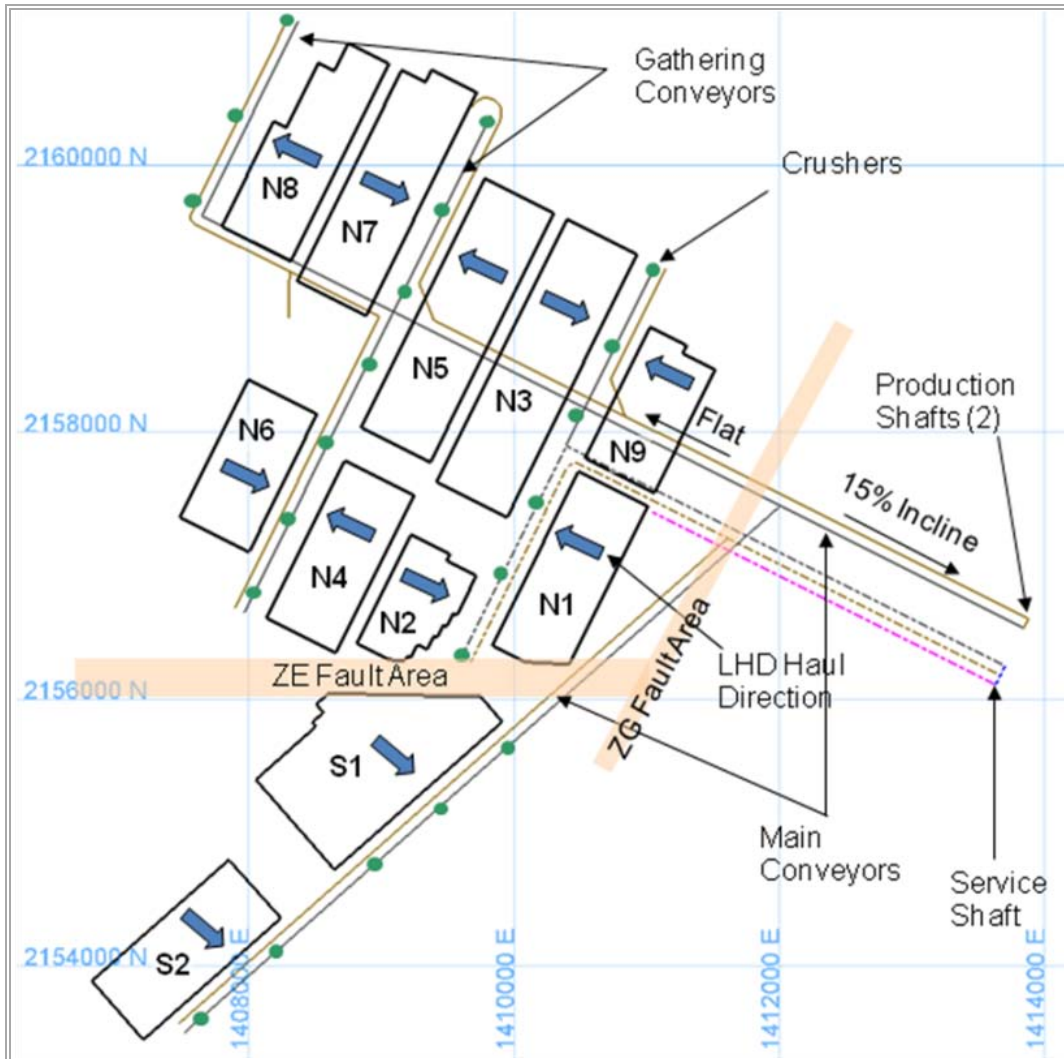
Figure 18.1.13 Typical Extraction Level



**HAULAGE LEVEL DEVELOPMENT**

The main rock handling system consists of conveyor haulage of the ore from the jaw crushers to the production shafts. Gathering conveyor drifts (18.0 ft high x 18.0 ft wide) are located 100 ft below the extraction level. A maintenance drift parallels the conveyor drifts for intermediate access to the conveyor and crusher load-out. An illustration of the haulage level is presented in Figure 18.1.14.

Figure 18.1.14 Haulage and Conveyor Layouts



**VENTILATION DEVELOPMENT**

The total ventilation required at 150,000 tons per day is 6.9 million cfm, which averages 45.7 cfm/tpd. Conceptually, the underground mine will be ventilated using a pull ventilation system. Heated intake air enters the mine at the service shaft and at an intake shaft. All air exhausts out the production shaft and an exhaust shaft. An illustration of the overall ventilation system is presented in Figures 18.1.15 and 18.1.16.

Figure 18.1.15 Overall Ventilation Schematic

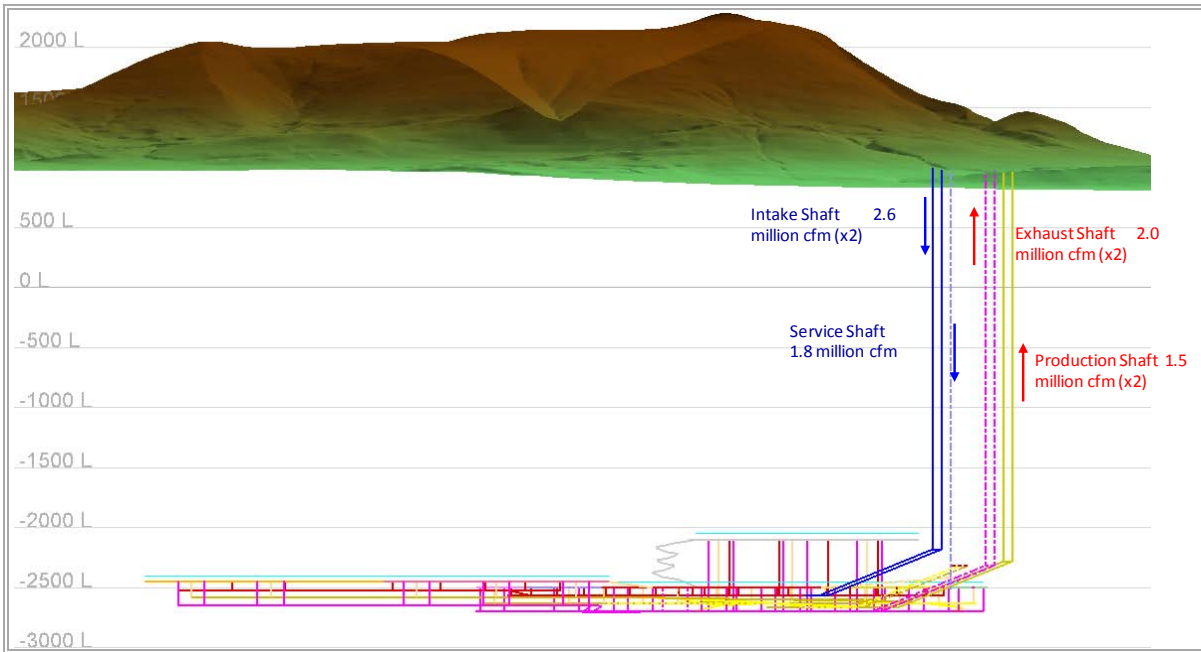


Figure 18.1.16 Ventilation Layout





### *Intake*

The 33 ft-diameter service shaft will be used to provide up to 1.8 million cfm of heated intake air. The remaining 5.1 million cfm will enter the mine through two 31.5 ft-diameter intake shafts.

Intake air is delivered to the footprint area via the main access drifts, and through four dedicated 26 ft high x 26 ft wide intake drifts. Upon reaching the footprint, the majority of the intake air will be distributed via 8 ft diameter intake raises to the extraction level perimeter drifts.

### *Exhaust*

The design includes two dedicated production shafts and two exhaust shafts to move return air from the underground to surface. Once the connection between the service shaft and the exhaust shaft is made during the pre-production period, the exhaust shaft will serve as the primary exhaust airway throughout the mine life. The velocity in the production shafts is 2,000 fpm to allow the use of rope guides; therefore, the ventilation capacity is 1.5 million cfm per shaft. The remaining exhaust capacity required is 3.9 million cfm, assuming a maximum velocity of 3,500 fpm in the two dedicated exhaust shafts; the shaft diameter must be at least 30 ft.

Four 26 ft high x 26 ft wide dedicated ventilation drifts will deliver the return air from the footprint to the exhaust shaft. The dedicated exhaust drifts will be driven along the perimeter of the footprint (opposite the intake drifts), below the extraction level and will access the bottoms of 8 ft diameter exhaust raises.

### MISCELLANEOUS INFRASTRUCTURE

Shops will be located on the extraction level with access to two mining blocks. Each shop will include 11 bays and is equipped to service electric LHDs, secondary breaking rigs, jumbos, rock bolters and support equipment. Welding facilities and an electrician shop will be available, and office space provided for maintenance supervision. A wash bay will be positioned so all equipment entering the shop can be washed prior to service.

Diesel fuel will be delivered underground using a fuel drop system located in the service shaft. Fuel trucks will deliver fuel from the underground main station at the shaft to the extraction level fuel and lube station.

Average annual inflows have been used in this study to estimate dewatering cost and power requirements.

It is anticipated that the site-wide power generation facility will not be operational until 69 months from the start of the project. As a result, all development and construction activities for the pre-production period will be completed using diesel-powered generating plants located at the service shaft surface facility. The peak power load for underground development is estimated at 109.34 megawatts in Year 23 of the project, at an average diversified running load of 70.33 megawatts.

ROCK HANDLING

The rock handling system will utilize conveyors to transport production muck from the crushers to the production shafts where it will be hoisted to surface.

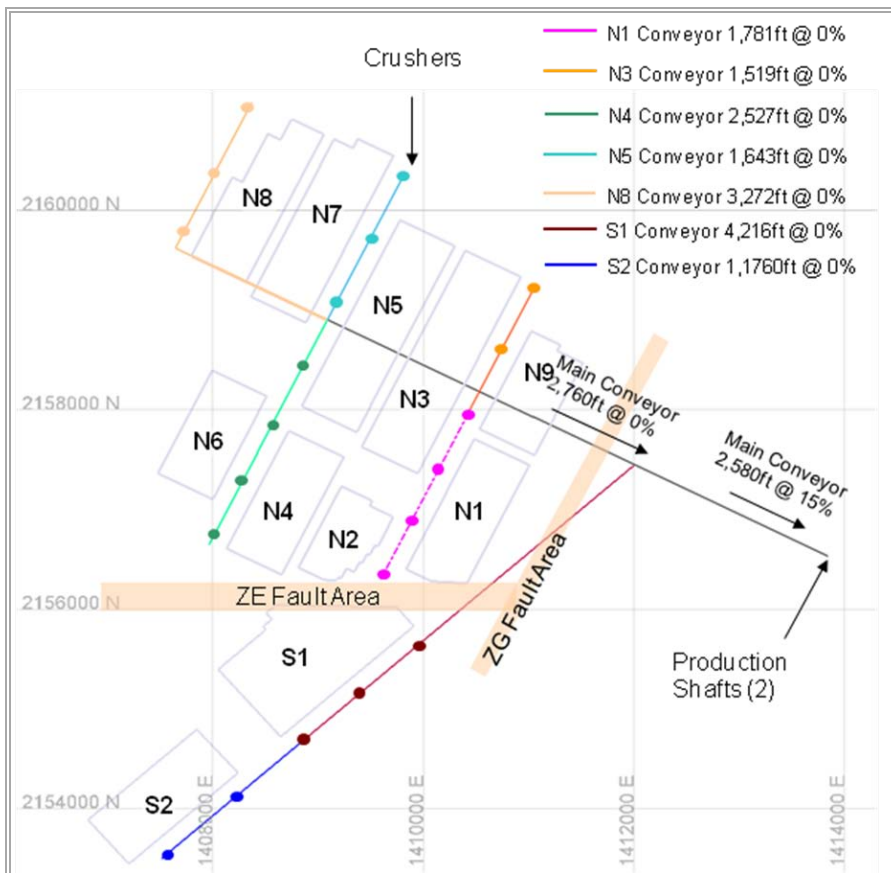
Ore Haulage

Electric LHDs on the extraction level will transport ore from the drawpoints to jaw crushers located along the perimeter drift. The estimated average productivity of the production LHDs is 3,366 tons per day per operating unit per 50,000 tons per day mining block. Based on this productivity, an average of 45 total operating LHDs will be required when the targeted production rate of 150,000 tons per day is achieved.

The 63-inch x 75-inch jaw crushers are located at the extraction level next to the mining blocks, and are used to reduce the ore to the prescribed lump size of minus 6 inches. The crushed ore will be transferred to gathering belts on the haulage level below, which will bring the ore to one of two main belts and from there to the shaft bins. A schematic of the conveyor layout is shown in Figure 18.1.17.

Ore will be hoisted out of the mine using two 60,000 tons per day production shafts dedicated for ore hoisting. The remaining 30,000 tons per day will be hoisted through the service shaft.

Figure 18.1.17 Conveyor Schematic



*Development Waste Haulage*

During the pre-production period, development muck will be transferred to surface by hoisting through the service shaft. Once the muck reaches surface, surface haulage equipment transport the rock to either the mill or designated waste storage pads.

**MINEABLE RESOURCE SUMMARY**

Production scheduling has been performed for each of the mining blocks shown in Table 18.1.23 and Figure 18.1.18. The production schedules include grades and tons by year for NSR, copper, gold and molybdenum energy (for comminution evaluations), and density.

NSR values have been calculated into the mining blocks using commodity values of US\$1.85/lb of copper, US\$902/oz of gold, and US\$12.50/lb of molybdenum. Using an NSR cut-off value of \$20/ton, the highest value mining blocks have been selected based on the geotechnical criteria to support 50,000 tons per day per block. Inputs to the NSR calculations are found in Table 18.1.21.

**Table 18.1.21 Underground Mining NSR Inputs**

	Value	Units
<b>Prices</b>		
Copper	1.85	\$/lb
Gold	902.00	\$/oz
Molybdenum	12.5	\$/lb
<b>Mill Recovery</b>		
Copper to Cu Conc.	90.20	%
Gold to Cu Conc.	64.90	%
Molybdenum	91.00	%
<b>Copper Concentrate</b>		
Conc. Grade Cu	26.00	%
Conc. Grade Au	0.6	oz/ton
Moisture Content	7.50	%
<b>Moly Concentrate</b>		
Conc. Grade Mo	50.00	%
<b>Payables: Cu-Au Conc.</b>		
Copper	99.00	%
Gold	91.50	%
<b>Payables: Mo Conc.</b>	<b>98.50</b>	<b>%</b>
Molybdenum		
<b>Process Charges (Cu)</b>		
Freight	50.00	\$/wet ton
Smelting	85.00	\$/dry ton
Refining	0.085	\$/lb
Price Participation	0.000	\$/dry ton

*Table continues...*

*...Table 18.1.21 (cont'd)*

	Value	Units
<b>Process Charges (Au)</b>		
Freight	0.60	\$/oz
Smelting		\$/dry ton
Refining	9.02	\$/oz
<b>Process Charges (Mo)</b>		
Freight	0.50	\$/lb
Smelting		\$/dry ton
Treatment	0.92	\$/lb
<b>Royalties</b>		
Copper	0.00	%
Gold	0.00	%
Molybdenum	0.00	%
<b>Process Fees (Cu)</b>		
Freight	0.1050	\$/lb
Smelting	0.1651	\$/lb
Refining	0.0850	\$/lb
Price Participation	0.0000	\$/lb
TRCs	0.3551	\$/lb
<b>Process Fees (Au)</b>		
Freight	0.6557	\$/oz
Smelting	0.0000	\$/oz
Refining	9.0200	\$/oz
TRCs	9.6757	\$/oz
<b>Process Fees (Mo)</b>		
Freight	0.5000	\$/lb
Smelting	0.0000	\$/lb
Refining	0.9200	\$/lb
TRCs	1,4200	\$/lb
<b>Value Per 1 Grade Unit</b>		
Copper	26.6983	
Gold	529.8934	
Molybdenum	198.6312	
<b>Typical Ore &amp; Value</b>		
Copper (Cu)	0.4434	%
Gold (Au)	0.002752	oz/ton
Molybdenum (Mo)	0.04	%
<b>Total Value</b>	<b>20.360</b>	<b>\$/ton</b>
<b>Other Data Needed</b>		
Mining Cost	7.92	\$/ton milled
Milling Cost	4.19	\$/ton milled
Tailings Cost	0.63	\$/ton milled
G&A Cost	1.77	\$/ton milled
<b>Total Cost Per Ton</b>	<b>14.51</b>	<b>\$/ton milled</b>

SCHEDULES

*Pre-Production*

Based on the underground mine design and associated infrastructure requirements, a conceptual pre-production schedule has been developed, with major milestones shown in Table 18.1.22. The total estimated duration to complete the development and construction requirements to initiate production is approximately five years. The following lists the key components of the underground design that are scheduled to be complete during the pre-production period.

- Service Shaft Sinking and Commissioning;
- Ventilation Shaft Sinking and Commissioning;
- Crusher No. 1 Excavation and Commissioning;
- Main Conveyor No. 1 Decline and Installation;
- N1 Undercut Level Access Ramps;
- Exhaust Drifts and Raises from N1;
- Ventilation Drifts between the Footprint and the Shafts;
- Main Pumping System with 15,000 gal/min Pumping Capacity;
- Drill/LHD Shop; and
- Underground Offices / Warehousing / Main Powder and Cap Magazine.

**Table 18.1.22 Pre-Production Milestone Summary**

Activity	Date
Project Start	Year -5
Sink Service Shaft	Year -4
Sink Ventilation Shaft	Year -3
Commission Service Shaft	Year -2
Breakthrough Connection between Shafts and N1	Year -1
Commission Crusher No. 1	Year 1
Commission Conveying System	Year 1
Earliest Production Start Date – Initiate Undercutting	Year 1

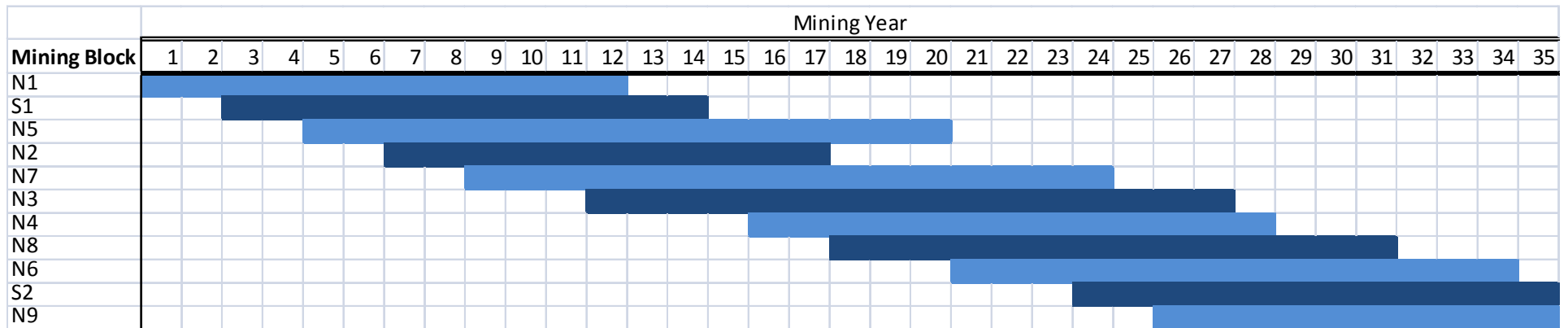
*Production*

A total of 1,459 million tons of ore can be mined over a 35-year underground mine life. Ramp up to full production is approximately eight years, at which time the annual production rate will be 54 million tons per year (150,000 tons per day at 360 days per year). Based on this schedule, full production is sustained for 16 years, followed by an 11 year tail-off period as final drawpoints close. The life-of-mine underground production schedule with average grades is presented in Table 18.1.23 and Figure 18.1.18.

**Table 18.1.23 Underground Production Schedule Summary**

Block ID	N1	S1	N5	N2	N7	N3	N4	N8	N6	S2	N9	Totals
Mining Years	1 to 12	3 to 14	5 to 20	7 to 17	9 to 24	12 to 27	16 to 28	18 to 31	21 to 34	24 to 35	26 to 35	
Tons mined	128,769,288	126,534,539	190,513,355	76,526,527	181,601,684	179,280,522	135,617,450	133,575,972	126,124,510	113,017,219	67,724,871	1,459,285,937
New Drawpoints	276	437	399	150	350	420	252	274	220	263	183	3,224
NSR (\$/ton)	35.53	36.26	25.29	29.15	26.16	26.33	22.03	23.78	18.92	32.04	30.65	27.36
Cu (%)	0.898	0.841	0.595	0.674	0.539	0.647	0.490	0.474	0.334	0.703	0.783	0.621
Au (oz/ton)	0.012	0.020	0.007	0.014	0.013	0.006	0.010	0.013	0.011	0.012	0.006	0.011
Mo (ppm)	301	197	323	223	287	342	207	249	239	403	379	287
Energy	9.41	9.13	10.72	8.86	11.32	10.89	8.65	12.48	8.57	9.03	10.89	10.12

**Figure 18.1.18 Underground Production Schedule by Mining Block**



## SUSTAINING DEVELOPMENT AND CONSTRUCTION

Sustaining development and construction will include perimeter drifts, panel and drawpoint drifts, drawpoint construction, internal vent raises, orepasses, and undercut level development. Sustaining development and construction is scheduled on a per drawpoint basis over the life of the mine based on the drawpoint equipping schedule.

## PERSONNEL

The following presents an estimate for both contractor and owner personnel required to develop, construct, operate, and support the Pebble East block cave mine.

During the pre-production development period, the peak year for contractor personnel working onsite is Year -1, with an estimated 199 persons onsite.

The peak year for owner's personnel requirements is in Year 6. During this year, the estimated working personnel is 555, and payroll personnel is 808 (totals include operating directs, indirects, and sustaining capital development personnel). Based on the production schedule and the estimated working personnel requirements, the average life-of-mine productivity is approximately 144 tons per manshift.

## MOBILE EQUIPMENT SCHEDULE

Operating mobile equipment requirements have been estimated on an annual basis over the life of the mine. Equipment quantities have been estimated from the number of development and construction crews, production requirements, weighted average haul distances, personnel requirements, secondary breaking, repair crews, among other factors.

An availability factor of 85% has been assessed against the annual operating quantities for each type of equipment.

The equipment purchase, rebuild, and replacement schedules have been estimated from these requirements and are included in the capital cost estimate.

## COST ESTIMATES

### *Capital*

Capital costs for the development and operation of the proposed Pebble East block cave mine are defined as pre-production capital (i.e. prior to start of production) and sustaining capital (i.e. capitalized expenditures over the life-of-mine). All costs are represented as current US dollars. A summary of the life-of-mine capital costs are presented in Table 18.1.24.

**Table 18.1.24 Underground Capital Cost Summary (US\$ millions)**

Capital Development	Pre-Production	Sustaining	Total
Contractor Mob/Demob/Setup/Teardown	5.71	4.69	10.39
Lateral Development	100.55	212.64	313.18
Shaft Sinking and Construction	139.15	227.96	367.11
Raise and Borehole Development	1.00	22.10	23.10
Development Material Handling	11.81	7.55	19.36
Surface Facilities Construction	110.78	5.41	116.19
Underground Construction and Installation	23.21	75.09	98.30
Contractor Indirects and Margins	230.85	136.33	367.18
Mobile Equipment	89.36	1,406.17	1,495.53
Fixed Equipment	256.27	350.28	606.55
EPCM and Owner's Costs	86.19	51.17	137.37
Electrical Power	58.91	–	58.91
Contingency @ 25%	272.64	624.84	897.48
<b>Total</b>	<b>1,386.43</b>	<b>3,124.23</b>	<b>4,510.65</b>

### *Operating*

Operating costs include direct and indirect costs associated with ore production and sustaining development. Operating cost items include the following elements.

- Extraction Level Development and Construction;
- Undercut Level Development;
- Repairs;
- Direct Production
  - Undercutting
  - Drawbelling;
- Rock Handling
  - LHD Operations
  - Secondary Breaking
  - Crushing
  - Conveying
  - Hoisting;
- Power;
- Indirect Costs
  - Staff Labour
  - Hourly Labour
  - Services
  - Support Equipment Operating.



Over the production period, approximately 1,459 million tons will be extracted from the underground development. Life-of-mine operating expenditures are estimated at \$7.43 billion, resulting in an average life-of-mine operating cost of \$5.09/ton with a full-production operating cost of \$4.88/ton. A summary of the operating costs for a typical full production year is presented in Table 18.1.25.

**Table 18.1.25 Unit Operating Cost Summary for Typical Full Production Year**

Description	Cost (\$/t)
Lateral Development (Undercut and Extraction Levels)	0.40
Production Directs	0.34
Construction	0.19
Material Handling	1.17
Maintenance and Repairs	0.07
Support Equipment Operating (Excludes Labour)	0.18
Mine Services (Excludes Labour)	0.23
Indirect Labour – Staff	0.38
Indirect Labour – Hourly	1.02
Electrical Power @ \$0.066/kWh	0.92
<b>Total Full Production Operating Cost</b>	<b>4.88</b>

#### LIFE-OF-MINE EXPENDITURE SCHEDULE

The life-of-mine capital and operating cost expenditure is estimated at \$11.942 billion dollars over a 35 year period. Based on the 1,459 million tons scheduled to be produced from the underground, the total capital and operating cost per ton is \$8.18 and the sustaining capital and operating cost is \$7.23/ton. Life-of-mine expenditures are presented on an annual basis in Table 18.1.26.

**Table 18.1.26 Annual Expenditure Schedule**

Item	Units	Year -6	Year -5	Year -4	Year-3	Year -2	Year -1	Year 1	Year 2	Year 3	Year 4	Year 5	Year 6	Year 7	Year 8	Year 9	Year 10	Year 11	Year 12	Year 13	Year 14	Year 15
Pre-production Capital	\$M	34.66	138.64	207.96	277.29	346.61	381.27	-	-	-	-	-	-	-	-	-	-	-	-	-	-	-
Sustaining Capital	\$M	0.00	0.00	0.00	0.00	0.00	0.00	312.42	234.32	234.32	78.11	78.11	78.11	78.11	78.11	78.11	78.11	78.11	78.11	78.11	78.11	78.11
Operating Cost	\$M	0.00	0.00	0.00	0.00	0.00	0.00	47.46	131.83	138.86	132.25	165.60	180.38	215.36	259.04	263.66	263.66	263.66	263.66	263.66	263.66	263.66
<b>Total</b>	<b>\$M</b>	<b>34.66</b>	<b>138.64</b>	<b>207.96</b>	<b>277.29</b>	<b>346.61</b>	<b>381.27</b>	<b>359.88</b>	<b>366.15</b>	<b>373.17</b>	<b>210.35</b>	<b>243.70</b>	<b>258.48</b>	<b>293.46</b>	<b>337.15</b>	<b>341.77</b>	<b>341.77</b>	<b>341.77</b>	<b>341.77</b>	<b>341.77</b>	<b>341.77</b>	<b>341.77</b>
Operating Cost per ton	\$/ton	-	-	-	-	-	-	58.59	36.62	14.65	7.32	6.10	4.88	4.88	4.88	4.88	4.88	4.88	4.88	4.88	4.88	4.88
Operating and Sustaining Capital Cost per ton	\$/ton	-	-	-	-	-	-	444.30	101.71	39.37	11.65	8.98	7.00	6.65	6.35	6.33	6.33	6.33	6.33	6.33	6.33	6.33

Item	Units	Year 16	Year 17	Year 18	Year 19	Year 20	Year 21	Year 22	Year 23	Year 24	Year 25	Year 26	Year 27	Year 28	Year 29	Year 30	Year 31	Year 32	Year 33	Year 34	Year 35	
Pre-production Capital	\$M	-	-	-	-	-	-	-	-	-	-	-	-	-	-	-	-	-	-	-	-	
Sustaining Capital	\$M	78.11	78.11	78.11	78.11	78.11	78.11	78.11	78.11	78.11	78.11	78.11	78.11	78.11	78.11	78.11	78.11	78.11	78.11	78.11	78.11	0.00
Operating Cost	\$M	263.66	263.66	258.20	263.66	263.66	263.66	263.66	263.66	263.66	263.66	258.76	250.75	253.76	240.57	232.37	217.21	190.03	141.48	85.05	54.71	
<b>Total</b>	<b>\$M</b>	<b>341.77</b>	<b>341.77</b>	<b>336.30</b>	<b>341.77</b>	<b>341.77</b>	<b>341.77</b>	<b>341.77</b>	<b>341.77</b>	<b>341.77</b>	<b>341.77</b>	<b>336.87</b>	<b>328.86</b>	<b>331.86</b>	<b>318.67</b>	<b>310.48</b>	<b>295.31</b>	<b>268.13</b>	<b>219.59</b>	<b>163.15</b>	<b>54.71</b>	
Operating Cost per ton	\$/ton	4.88	4.88	4.88	4.88	4.88	4.88	4.88	4.88	4.88	4.88	4.88	4.88	4.88	4.88	4.88	4.88	4.88	4.88	4.32	4.32	
Operating and Sustaining Capital Cost per ton	\$/ton	6.33	6.33	6.36	6.33	6.33	6.33	6.33	6.33	6.33	6.33	6.36	6.40	6.39	6.47	6.52	6.64	6.89	7.58	8.29	4.32	

## 18.2 INFRASTRUCTURE

---

### 18.2.1 INTRODUCTION

Pebble will be a greenfield project and as such requires the development of supporting infrastructure. In addition to requisite infrastructure at the mine site, such as maintenance facilities, offices, utilities, and worker accommodation, several key primary infrastructure components must be constructed. These include a tidewater port for concentrate off-loading and trans-shipment of operating supplies; an access road to connect the mine site with the port and the existing airport at Iliamna; pipelines for concentrate, reclaim water, diesel fuel, and natural gas transport; and electrical power generation facilities.

While these additional infrastructure components add complexity to the project, models for this development do exist – including Red Dog in Alaska. In addition, concentrate transport at many copper mines currently operating, under construction, or contemplated in South America or Asia, utilize concentrate pipelines, which have become a well understood and economically viable alternative to truck haulage.

Pebble does have a number of key advantages. One, while there are few existing roads in the area, much of the road route follows rolling, glaciated terrain, which will minimize construction costs and times. The existing state-run airport at Iliamna is a high quality facility, which would cost tens of millions of dollars to replicate. The deposit is located at approximately 1,000 ft amsl, which eliminates many of the issues associated with high altitude developments. The selected port site has deep water immediately offshore, enabling loadout pier construction without the need for a long jetty or lightering. Further, it is ice-free for 11 months of the year, obviating the need for long storage periods for concentrate and supplies.

### 18.2.2 SITE CONDITIONS

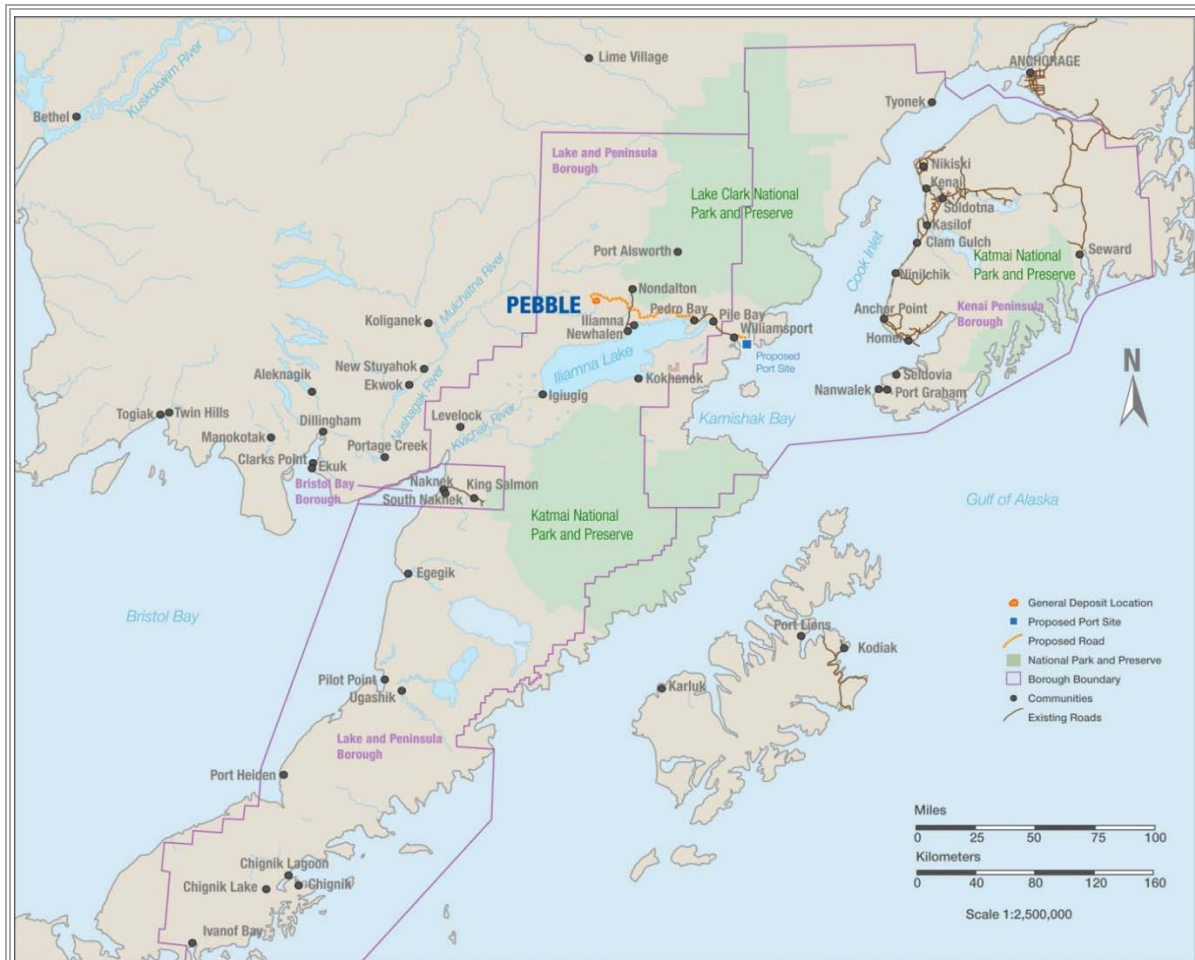
A map of the Pebble location is shown in Figure 18.2.1.

#### SITE CONDITIONS – MINE SITE

Terrain in the mine site area features rolling hills and low mountains separated by wide shallow valleys blanketed with glacial deposits and numerous streams and small, shallow lakes (Figure 18.2.2). The deposit is located at the top of three drainages; two branches of the Koktuli River (the South and North Koktuli) which drain southwest to the Mulchatna River, and the Upper Talarik Creek which drains into Lake Iliamna.

The climate of the Pebble Project area is classified as maritime continental. The Japanese Current as well as the open waters of the Bering Sea and Cook Inlet moderate summer temperatures, but winter temperatures are more continental in nature due to the presence of sea ice in Bristol Bay during the coldest months of the year. The climate is generally moderate, with a mean daily maximum temperature of 63°F in July and a mean daily minimum temperature in January of 8.6°F. The maximum and minimum temperatures recorded at the project site are 66.6°F and -29.5°F respectively.

Figure 18.2.1 Location Map of the Pebble Project



**Figure 18.2.2 Topography of Pebble Mine Site**



Mean annual precipitation varies throughout the project area and is basin and elevation specific, but typically ranges from 35 inches to 45 inches. Approximately 30% to 35% of precipitation at the mine site falls as snow.

Elevations in the project area range from 820 ft amsl to 2,759 ft amsl. The mine site is at an elevation approximately 650 ft higher than that of Iliamna and is surrounded by a number of mountain peaks that rise to elevations of over 2,600 ft. As such, the orographic effects result in approximately 33% greater annual precipitation at the mine site than at Iliamna.

Monthly wind roses in the mine site area indicate that the wind predominantly blows from the northeast and southeast and consistently averages between 10.5 mph and 28.9 mph.

Limited local roads connect the villages of Newhalen, Iliamna and the Iliamna airport, and extend to a future bridge crossing off the Newhalen River, near Nondalton. There is also an existing road connecting the villages of Pile Bay and Williamsport.

The communities of Iliamna, Newhalen and Nondalton have a combined population of approximately 439 people. The State of Alaska manages an airfield at Iliamna with two 5,000 ft runways, suitable for 737 passenger and DC-6 and Hercules cargo aircraft.

Iliamna and surrounding communities have limited commercial business infrastructure, except for that which services a seasonal sports fishing and hunting industry. A small hydroelectric installation on the Tazimina River provides power for the three communities.

The site lies within a relatively active seismic zone that would have been defined as Zone 3 by the now superseded Uniform Building Code (UBC). The new International Building Code (IBC) defines the seismic zone by the parameters  $S_s = 0.559g$ ;  $S_1 = 0.206 g$ .

## SITE CONDITIONS – PORT SITE

The proposed port, Port Site 1, is located on the western shore of Iniskin Bay on Cook Inlet, at latitude 59° 38' 50" N and longitude 153° 28' 10" W. Iniskin Bay is approximately 65 nautical miles west of the town of Homer. The coastal area of Cook Inlet has a maritime climate. Iniskin Bay is subject to fast ice extending from shore out to 1/8 of a mile off the coast in February. The bay is also subject to occurrences of floating pack ice between January and February.

The west side of Iniskin Bay at Port Site 1 is exposed to swell from the southeast. API guidelines suggest an extreme design wind speed for lower Cook Inlet as 104 mph. Tidal range in Iliamna Bay has a mean range of 12.5 ft and a diurnal range of 14.5 ft, with extremes of 16.4 ft. Maximum tidal currents are about 1 knot.

The nearest community served by a regional airport hub is Homer, Alaska, approximately 70 miles to the east. The Port of Homer has two dock structures and can accommodate barges and vessels up to 800 ft in length.

Temperatures at Port Site 1 are similar to Homer, Alaska. Mean annual maximum temperature is 44°F and mean annual minimum temperature is 30°F.

The proposed Port Site 1 on Iniskin Bay has no existing road access. The bay is presently used as a secure anchorage for medium-sized fishing vessels.

Port Site 1 is adjacent to deep water and does not require dredging for port access or mooring. The port's dock and loadout facilities have been designed for continuous operation during all stages of the average 14 ft tides. The dock face top is set at a height of 26 ft so that it will not be overtopped by either the modeled annual significant wave height of 5 ft or the modeled tsunami wave height of 6 ft.

Winter access is estimated to be limited during four weeks of the year as a result of ice conditions. Severe seasonal storms with wind and waves that prevent mooring at the dock have been modeled to last up to five days. Given this, the project facilities have been designed to store 35 days' worth of both incoming fuel and supplies and outgoing concentrates.

### 18.2.3 DESIGN CRITERIA

#### SITE ENGINEERING<sup>10</sup>

Design criteria for the site layout included the following:

- Minimize the difference in elevation and the horizontal distances between the open pit, mill site, crusher and tailings pond, with the intent of minimizing the capital cost and operating cost of the truck haul, conveyor haul and pipelines between these sites.
- Minimize the project footprint within the three stream systems– North Fork Koktuli River, Upper Talarik Creek and the South Fork Koktuli River.
- Site run-off and drainage from the mill site is to be contained by perimeter ditches and directed to a sedimentation pond, then to either the tailings facility or the water treatment system.

The following key design criteria were applied:

- Snow Loads
  - Ground snow load at the mine site = 75 lb/ft<sup>2</sup>
  - Ground snow load at the port = 350 lb/ft<sup>2</sup>
- Wind Loads
  - Basic wind speed at the mine site = 90 mph
  - Basic wind speed at the port site = 104 mph
- Seismic Loads
  - For the mine/mill site, the following design parameters will apply  $S_s=0.559$  grams;  $S_1=0.206$  grams
  - For the port site, the following design parameters will apply  $S_s=1.191$  grams;  $S_1=0.372$  grams.

#### 18.2.4 MINE SITE

The mine site will be developed in four areas: the open pit, the process plant site, the crusher and mine maintenance location, and the tailings storage facility. Roads and other utilities will connect these sites.

The process plant and associated facilities are located approximately 1,000 ft north of the open pit on level to rolling ground at the edge of the knoll which marks the north edge of the deposit. The site is covered with overburden, generally sand and gravel, and frost shattered bedrock. Site preparation will consist of levelling the site, generally with cut to fill, with the major components, such as the grinding mills, founded on bedrock. The current design includes a significant surplus of excavated rock, which offers an opportunity to further reduce costs by utilizing this material as fill for haul roads or tailings embankment construction.

The infrastructure components at the process plant site include:

- electric power generation plant;
- standby electric power generation;
- main substation and power distribution;
- potable and firewater storage and distribution;
- sewage treatment;
- laydown and container storage yard; and
- permanent camp and administration offices.

The mine maintenance and administration facilities will be located at the crusher site. The crusher site is located approximately 500 to 1,000 ft north of the open pit, on the east side of the knoll upon which the plant site is located.

## PORT SITE 1

The facilities at the port will include a barge dock berth, deep-sea ship dock, container storage and a handling area for 900 containers. On shore cut will be essentially balanced with the on shore fill plus the fill required for the container storage pad.

The infrastructure components at the port site include a power generation plant, accommodations and maintenance facilities, offices, fuel storage and transfer facilities.

### 18.2.5 SITE MOBILE EQUIPMENT

The plant and service mobile equipment is shown in Table 18.2.1.

**Table 18.2.1 Plant and Service Mobile Equipment**

Mobile Equipment		
<b>Process Plant</b>		
8 ton Truck, Flatdeck, with Crane, 5-ton Hiab or equivalent	1	Maintenance
8 ton Truck, Flatdeck, with Crane, 5-ton Hiab or equivalent	1	Maintenance
8 ton Truck, Flatdeck, with Crane, 5-ton Hiab or equivalent	1	Tailings crew
Fork-lift, 2-ton, Yale GP-TG or equivalent	1	Reagents
Fork-lift, 5-ton, Yale GC-MG or equivalent	1	Maintenance
Scissor-lift, 50 ft	1	Maintenance
Skid-steer loader, 1.5 yd <sup>3</sup> Cat 286B or equivalent	1	Crusher/conveyor
Skid-steer loader, 1.5 yd <sup>3</sup> Cat 286B or equivalent	1	Mill/stockpile
Track Dozer, Cat D8 or equivalent	1	Stockpile, tailings construction
Vacuum truck, 20-ton	1	Clean-up
<b>Engineering, Projects, &amp; Day Works</b>		
Pump Truck	1	Sewage
Water Truck, 250 gallons, c/w pump and spray bars	1	Water transport, dust suppression
Wheel-loader, Cat 966 or equivalent	1	Clean-up, show removal
Backhoe Loader, Cat 44D or equivalent	1	Yard maintenance, tailings construction
Dump Truck, 12 yd <sup>3</sup>	2	Yard maintenance
Grader All-Wheel Drive, Cat 16H or equivalent	2	Site & off-site roads
Tool carrier, Cat 1T-28 or equivalent	1	Yard maintenance
Track-mounted Crane, 150 tone	1	Construction
Lighting towers	2	Site & plant maintenance, tailings
Smooth drum vibratory compactor, 10 ton	1	Tailings construction
Sheep foot vibratory compactor, Cat 825 or equivalent	1	Tailings construction
Pipe trailer	1	Water system maintenance
Mobile Crane, 10 ton	1	Plant maintenance, tails lines, reclaim pumps, etc.
Mobile Crane, 25 ton	2	Site & plant maintenance
Mobile Crane, 50 ton	1	Site & plant maintenance
Lower loader, 100 ton	1	
<b>Electrical &amp; Power Distribution Maintenance</b>		
Truck-mounted hydraulic man basket (cherry picker), 50-ft lift	1	Electrical pole-line
Truck-mounted scissor-lift, 30-ft lift	1	Electrical, mechanical, instrumentation
Pole truck with auger	1	Electrical pole-line
Pole trailer	1	Electrical pole-line
Cable reel trailer	1	Electrical pole-line

*Table continues...*



... Table 18.2.1 (cont'd)

Mobile Equipment		
<b>Warehouse</b>		
8 ton truck, flatdeck, with crane, 5-ton Hiab or equivalent	1	Warehouse deliveries
Forklift, 2 ton electric	2	Warehouse
Forklift, 5 ton on extendable	1	Container de-stuffing
Forklift, 5 ton on all-terrain	1	Warehouse yard
Forklift, 30 ton container	2	Container handling
Container trailer	1	Container handling
Semi-trailer tractor, with hydraulic tipping attachment	1	Trailer handling
<b>Port</b>		
Grade, All-Wheel drive, Cat 16H or equivalent	1	Site & off-site roads
Skid-steer loader, 1.3 yd <sup>3</sup> cat 286B or equivalent	1	Cleanup
Wheel-loader, Cat 986G or equivalent	2	Concentrate loading
Wheel-loader, Cat 966 or equivalent	1	Clean-up, snow removal
Dump Truck, 12 yd <sup>3</sup>	1	Yard maintenance, snow removal
Forklift, 5 ton all terrain	1	Warehouse yard
Forklift, 30 ton container	2	Container handling
Container trailer	1	Container handling
Semi-trailer tractor	1	Container handling
<b>Safety, Security &amp; Environment</b>		
Ambulance	2	One at each end
Fire Engine	2	One at each end
Armoured Bullion Carrier	1	
<b>Administration</b>		
Minibus, 10-seat	3	Pool
Shift transport buses (50 passengers)	3	Crew transport at shift change
Site busses	2	Personnel transport to airport, etc.
<b>Process</b>		
Pick-up Crew Cab. 4x4	1	Crusher/conveyor crew
Pick-up Crew Cab. 4x4	1	Tailings crew
Pick-up 4 x4	1	Metallurgical/assay
Pick-up Crew Cab. 4x4	1	Operations supervisors
Pick-up Crew Cab. 4x4	2	Maintenance supervisors
Pick-up 4x4	1	Technical superintendent
Pick-up 4x4	1	Operations superintendent
Pick-up 4x4	1	Maintenance superintendent
Utility Vehicle, 4x4, Land Cruiser or equivalent	1	Process manager
<b>Engineering, Projects, &amp; Day Works</b>		
Utility Vehicle, 4x4 Land Cruiser or equivalent	1	Engineering manager
Pick-up Crew Cab 4x4	1	Services superintendent
Pick-up Crew Cab 4x4	1	Yard supervisor
Pick-up Crew Cab 4x4	1	Site maintenance superintendent
<b>Electrical &amp; Power Distribution Maintenance</b>		
Pick-up Crew Cab 4x4	1	Electrical
Pick-up Crew Cab 4x4	1	Instrumentation
Pick-up Crew Cab 4x4	1	Power line crew
<b>Warehouse</b>		
Pick-up, Crew Cab 4x4	1	Warehouse
<b>Port</b>		
Pick-up, Crew Cab 4x4	1	Maintenance supervisor
Pick-up, Crew Cab 4x4	2	Filter/loadout operations
Pick-up, Crew Cab 4x4	1	Transport operations

Table continues...

... Table 18.2.1 (cont'd)

Mobile Equipment		
<b>Safety, Security &amp; Environment</b>		
Pick-up 4x4	1	Safety
Pick-up 4x4	2	Security
Pick-up 4x4	1	Environment monitoring
Pick-up 4x4	1	HSE manager
Pick-up 4x4	1	Safety manager
Pick-up 4x4	1	
<b>Administration</b>		
Utility Vehicle, 4x4, Land Cruiser or equivalent	1	General manager
Utility Vehicle, 4x4, Land Cruiser or equivalent	1	Admin manager
Utility Vehicle, 4x4, Land Cruiser or equivalent	1	Operations manager
Pick-up 4x4	1	Materials superintendent
Pick-up 4x4	1	Warehouse supervisor
Pick-up 4x4	1	Human resources
Pick-up, Crew Cab. 4x4	1	Training
Pick-up, Crew Cab. 4x4	3	Pool

## 18.2.6 POWER GENERATION AND DISTRIBUTION

### POWER GENERATION

The selected means of supplying power for the project is a combined-cycle natural gas-fired turbine plant (CCGT) located at the mine site.

The proposed CCGT uses General Electric aeroderivative LM6000 gas turbines and steam turbines. All turbines have an approximate generating capacity of 45 MW (ISO). The power plant also includes once-through steam generators (OTSGs). The power plant is designed for N-1 redundancy. For the purposes of this study, N-1 redundancy implies that the loss of any single turbine, gas or steam, will not inhibit the plant's ability to meet the design electrical demand through gas-fired or combined-cycle operation or through supplemental firing.

Gas turbine generating capacity is inversely affected by the temperature of the turbine intake air. As ambient air warms, mass-flow through the turbine is decreased and power generating capacity is reduced. Given the mine's flat annual load profile, the power generating capacity matches the projected load during the summer at a peak design temperature of 74°F and 40% relative humidity – historically a relatively infrequent event.

To maintain the N-1 reliability criterion during the summer, it has been assumed that no turbines will be scheduled out of service for routine maintenance during this period. In addition, during the 'shoulder months', maintenance of the mills and other large equipment will be scheduled so as to reduce electrical demand during the maintenance outage window.

The historical annual average temperature condition at the mine site is 32°F and 72% relative humidity. Therefore, during most of the year, the plant will have sufficient capacity to meet the full mine load with N-1 redundancy and with one unit out of service on scheduled routine maintenance.

Meteorological data collected at the Pebble property indicates the potential for sufficient wind energy to support a viable wind power facility. Instruments have been purchased to further test this potential.

Four gas turbine models in the 40 to 100 MW range have been evaluated for life-cycle costs/benefit based on published ISO performance data. Heat and material balances were calculated to determine performance at both the high and average ambient temperature points at the project site. Minor shortfalls in capacity of less than 12 MW are expected to be covered by on-site standby diesel generation. Supplemental firing (SF) was introduced into the OSTGs to make up the capacity shortfall when practical. However, in some cases the gas turbines have been assumed to operate at part load where the heat and material balance showed that a better heat rate would be achievable compared to taking out one gas turbine and introducing supplemental firing in the other operating units.

The LM6000 model was selected for the power plant configuration for the following reasons:

- it provides the best heat rate, thus reducing fuel consumption and costs compared to the other options over the life of the plant;
- it provides the lowest cost of generation and lowest life-cycle costs;
- it is proven technology with the highest reported availability and reliability;
- there is minimal impact on power generation due to its relatively small low swirl combustion capacity (a flame stabilization concept for ultra-low emissions);
- the axial exhaust design allows better layout of the power plant; and
- the lower shipping weight avoids any transport constraints.

#### PLANT CONFIGURATION AND DESIGN DETAILS

The proposed plant will be built as a 5 x 5 x 3 configuration with five LM6000 PF gas turbines (215 MW), five supplementary fired OSTGs, and three non-reheat-type steam turbines (120 MW). The steam turbines will operate from common steam headers. The OSTGs are designed to run dry; no dump condenser will be required (Table 18.2.3). A sixth single cycle LM6000 gas turbine (43 MW) will also be installed to meet peak plant capacity requirements at the peak summer design temperature.

The plant design is based on the following criteria:

- All gas turbines are of dry low NO<sub>x</sub> design PF 15 model to produce 15 ppm by volume of dry NO<sub>x</sub> designed to fire pipeline-quality natural gas (single fuel). The gas turbines will also be provided with a Sprint spray water inter-cooling system to facilitate power augmentation during moderate to high ambient operation.
- OSTGs are provided with supplemental firing and SCR for NO<sub>x</sub> control, and with oxidation catalysts for control of carbon monoxide/volatile organic compound emissions. The OSTGs are designed for capacity modulation and dry running, eliminating the need for any dump.
- Simple cycle peaking units are also provided with a post-combustion NO<sub>x</sub>/carbon monoxide/volatile organic compound control feature.

- No additional fuel gas compressor is required. Fuel gas is assumed to be delivered at 725 psig by the pipeline system.
- Natural gas is assumed to be of pipeline quality with a higher heating value/lower heating value ratio of 1.106.
- A degradation factor of 2% is assumed for the life of the plant in all cases.
- Supplemental firing in OTSGs will be used to make up performance shortfalls only during an outage of any gas turbine.

The site parameters and fuel assumptions are summarized in Table 18.2.2.

**Table 18.2.2 Site Parameters and Design Operating Conditions for Power Plant**

Parameter	Basis
Elevation	1,200 ft ASL
Primary Fuel	Natural Gas (1)
Supplemental/Back Up Fuel	None
Design Basis Temperature/Relative Humidity	Summer 74°F/40%, Average 32°F/72% RH
Plant Net Installed Capacity (High Ambient Temperature)	378 MW
Redundancy Requirements	N-1

#### PLANT EFFICIENCY AND ELECTRICAL PERFORMANCE

The plant operating capacity and performance are based on the mine and processing plant configuration as defined at initial start-up.

#### DISPATCH SCENARIOS AND FUEL USAGE

Full 5 on 2 dispatch is required for both high and average ambient conditions to match the full load demand. The simple cycle turbine is held in reserve to cover loss of a unit. The plant is designed to operate with no units out of service for scheduled maintenance during the high ambient period without SF assistance.

In the event of a unit trip, system frequency is expected to be maintained by a combination of load shed and/or possible generator tripping. A preliminary assessment of the system stability was completed based on a 'close-in' three-phase fault on the 34.5 kV generator bus. This analysis demonstrated the plant may have difficulty riding through such events without a sophisticated load-shed program, as well as other mitigation schemes. This should be confirmed by additional stability modeling and analysis, and these schemes should be incorporated in the next phase of study.

The high ambient dispatch plant heat rate is approximately 7,619 Btu/kWh. For the average ambient temperature dispatch, the plant heat rate is modeled at 7,359 Btu/kWh. These figures yield an annual fuel consumption of between 18 and 18.5 Bf<sup>3</sup>/yr.

**PLANT EMISSIONS**

Annual emissions have been evaluated at the annual average ambient temperature, and maximum hourly emissions have been calculated for both the annual average ambient temperature and the high ambient temperature. The emissions calculation is based on the standby diesel generator operating at 12 MW and base load for 50 h/yr.

**WATER USE**

All raw water will be provided to the power plant from either groundwater wells or treated reclaim water. The vast majority of the water consumed, over 85%, is a result of evaporation from the cooling towers. Raw water can be provided from any source, so long as it has been processed to the required state of purity. In general, reverse osmosis filtering can provide processed water of the quality found in the cooling water quality specification in the main report.

**Table 18.2.3 Heat Balance**

Combined Cycle Power Plant Options with LM6000 PF Sprint				
Item	Description	Units	High Ambient 280 MW Plant Load	Avg Ambient 280 MW Plant Load
<b>A. Configuration</b>				
1	Power Train Configuration		5x5x2+1 Simple Cycle GT	
<b>B. Operation Description</b>				
1	Ambient Temperature	°F	74	32
2	Ambient Relative Humidity	%	40%	72%
3	Ambient Wet Bulb Temperature	°F	59	29
4	Elevation	Ft	1200	1200
5	Supplementary Firing		Yes	No
6	Inlet Air Evaporating Cooling		On	Off
7	CTG/HRSGs in Operation		5	5
8	CTG Operation in SC		No	No
9	CTG Load	%	100%	99%
10	Sprint Orientation		Yes	No
11	STGs in Operation		2	2
12	Mine Heat Load	MWth	25	25
<b>C. Cycle Operating Parameters per Unit (Unless otherwise stated)</b>				
1	CTG Exhaust Temperature	°F	852	833
2	Stack Exit Temperature	°F	219	222
3	HRSG HP Steam Production	kpph	106	91
4	HP Steam Trottle Temperature	°F	846	792
5	HP Steam Trottle Pressure	psia	846	713
6	HP Steam Trottle Floe per STG	kpph	265	228
7	HRSG LP Steam Production	kpph	32	35
8	LP Steam Addition Temperature	°F	385	382
9	LP Steam Pressure	psia	59	52
10	LP Steam Flow to each STG	kpph	41	48
11	HP Pinch Point Temperature	°F	17	14
12	LP Pinch Point Temperature	°F	20	20
13	STG Exhaust Flow	kpph	306	278
14	STG Exhaust Enthalpy	BTU/lb	999	989
15	STG Exhaust Pressure	in HgA	2.71	2.29
16	STG Exhaust Quality	%	89%	89%

Table continues...

... Table 18.2.3 (cont'd)

Combined Cycle Power Plant Options with LM6000 PF Sprint				
Item	Description	Units	High Ambient 280 MW Plant Load	Avg Ambient 280 MW Plant Load
17	Cooling Tower Approach	°F	16	43
18	Cooling Tower Flow- Total	gpm	50,637	50,637
19	Cooling Tower Range	°F	22	20
20	LP Steam for Mine Heating - Total	kpph	81	81
<b>D. Estimated Plant Performance (1-3)</b>				
1	CTG Output, each	kW	43,699	45,700
2	STG Output each	kW	35,126	30,158
3	STG Output Total	kW	70,253	60,316
4	Gross Plant Output	kW	288,748	288,818
5	Aux loads and Losses(3)	kW	8,662	8,664
6	STG to CTG Output Ratio	%	32.15%	26
7	Net Plant Output	kW	280,085	280,152
8	Net Plant Heat Rate, LHV	Btu/kWh	6,870	6,636
9	Net Plant Heat Rate	Btu/kWh	7,619	7,359
<b>E. Estimated Fuel Consumption (2)</b>				
1	CTG Fuel Consumption LHV, each	MMBH	365	372
2	DB Fuel Consumption	MMBH	20	0
3	Total Fuel Gas Consumption LHV	MMBH	1,924	1,859
4	Total Fuel Gas Consumption HHV	MMBH	2,134	2,062
5	Total Fuel Gas Consumption LHV	Mcf/Day	45,679	44,132
	Total Fuel Gas Consumption HHV	Mcf/Day	50,658	48,943
	Total Fuel Gas Consumption LHV	Mcf/Year	16,672,722	16,108,314
6	Total Fuel Gas Consumption HHV	Mcf/Year	18,490,049	17,864,121
<b>F. Water Consumption (4)</b>				
1	Cooling Tower Evaporation Losses - Total(5)	gpm	1,040	663
2	Cooling Tower Drift Losses - Total	gpm	1	1
3	Cooling Tower Blowdown - Total(4)	gpm	130	83
4	Total Cooling Tower Makeup	gpm	1,171	747
5	Evap Cooler (2COC)	gpm	57	0
6	Demin Water for Sprint Flow	gpm	89	0
7	Demin Water for Cycle Makeup	gpm	18	18
8	Total Demin Water Consumption	gpm	107	18

**Notes:**

1. All performance are at new and clean condition unless otherwise noted. CTG Performance was estimated using GT Pro software. Steam Cycle data is based on GateCycle.
2. Fuel Gas Heating Value: 21,515 Btu/lb. Fuel gas will be supplied at the plant boundary at a pressure 725 psig. No gas compressor is included.
3. Aux Load is assumed as 3% of gross output.
4. The cooling tower blowdown is based on 9 Cycle of Concentration.
5. Evaporation Losses include additional 10% for auxiliary cooling.

**FUEL SUPPLY**

*Routing and Potential Sources*

It is a basic premise of this evaluation that the Cook Inlet gas field does not currently have an adequate supply of natural gas to meet the Pebble Project requirements, although supply is anticipated to become available in the future. Potential sources could be either the “Bullet Line” from Alaska’s Gubik gas field or a spur line from the North Slope gas sales pipelines. This gas from outside the Cook Inlet

region would backflow through existing pipelines and be available for Pebble power generation. Another option is the importation of liquefied natural gas (LNG).

A fuel gas supply pipeline to serve the Pebble Project is expected to originate from existing lines on the east side of the Kenai Peninsula and cross Cook Inlet from some point near Anchor Point, where the gas would be compressed. The pipeline-traverse across lower Cook Inlet will be approximately 60 miles in an externally coated, heavy-wall pipe to Port Site 1. Recent trends in sub-sea pipelines include heavy-wall pipe to ensure negative buoyancy and protect against physical damage from anchors.

At the port site on the west side of Cook Inlet, approximately 3 M ft<sup>3</sup>/d of gas will be tapped for power generation at the port site. The rest of the fuel gas will be routed west approximately 86 miles via buried pipeline following the road to the power plant at the mine site. Table 18.2.4 provides the specifics of the fuel supply requirements.

**Table 18.2.4 Natural Gas Pipeline Details**

Pipeline Leg	Diameter (in.)	Wall Thickness (in.)	Compression
Kenai Peninsula	12	0.250	none
Across Cook Inlet	8	0.719	10,000 hp (2 stage)
Port Site 1 to Mine Site	8	0.250	none

Selected pipe sizes are based on optimizing full life-cycle costs (capital plus operating) for the pipeline. In this instance, a single combination of pipe sizes will be sufficient for the full range of fuel gas flow anticipated.

The gas transportation system will be optimized during the next phase of study.

**18.2.7 POWER DISTRIBUTION**

Power will be delivered to the mine site substation through a 230 kW electric transmission line system. Preliminary average power demands for the project mine site are shown in Table 18.2.5.

**Table 18.2.5 Preliminary Average Power Demand (MW)**

Area	Power Demand
Crushing, conveying and coarse ore storage	17.5
Grinding circuit	161.4
Copper flotation and regrind circuit	36.1
Molybdenum Recovery Circuit	1.0
Gold recovery circuit	7.3
Process services and utilities	19.0
On-site ancillary building and facilities (admin. facilities, permanent camp, truck shop, etc.)	2.7
Open pit mining (electric shovels, electric drills, etc.)	17.6

*Table continues...*

... Table 18.2.5 (cont'd)

Area	Power Demand
Tailings and reclaim system	15.6
Water system (Newhalen River fresh water pump station)	4.8
Pipeline pump stations (Concentrate pipeline, return water pipeline and diesel transfer pipeline)	1.7
Port Site Concentrate handling and miscellaneous facilities	2.4
Net average power demand (MW)	287.1

The mine site power distribution systems will consist of:

- a common 34.5 kW, 3 phase, 3 wire, single-circuit overhead power line to the administration facilities and permanent camp complex;
- a common 34.5 kW, 3 phase, 3 wire, single-circuit overhead power line to service the crushing and conveying areas, truck shop facilities, continuing to the perimeter of the open pit and to the emulsion plant facility;
- a common 34.5 kW, 3 phase, 3 wire, single-circuit overhead power line to service the process water storage pond pump house, continuing to the tailings storage facility to service the reclaim water barge pump station;
- underground 34.5 kW feeder cables from the main substation to the process plant, 34.5 kW switchgear centres located in grinding area electrical rooms, and 34.5 kW sub-feed cables installed in cable ladder trays inside the process plant to feed various unit substations/motor control centres located at major load centres – such as grinding area, flotation area, pebble crusher area, and gold recovery area;
- underground 34.5 kW cables to feed the converter transformers of the gearless drive systems for the SAG Mills and ball mills; and
- a 34.5 kW, 3 phase, 3 wire, single circuit overhead power line to the open pit to service portable substations for electric powered mining shovels and electric powered blast-hole drills.

### 18.2.8 EMERGENCY POWER

Emergency power will be provided by diesel-fuelled generating sets, installed in the following locations:

- process plant (four 1500 kW diesel generators for a total of 6 MW capacity);
- process water storage pond pump house (one 1500 kW diesel generator);
- truck shop facilities (one 1500 kW diesel generator);
- permanent camp complex and administration facilities (four 750 kW diesel generators for a total of 3 MW capacity); and
- port site facilities (three 1500 kW diesel generator units for a total of 4.5 MW capacity).



In the event of a utility power failure, the emergency power generators will start automatically, providing power to essential loads (such as lighting, heating, and communication systems in buildings), and to emergency loads for selected process equipment in the process plant areas to ensure orderly shutdown and permit plant maintenance activities. Power and synchronizing panels will parallel the generators where required.

Emergency power will be provided to the essential loads necessary for personnel safety, plant equipment protection and plant maintenance. This will include emergency battery power packs located in various electrical rooms, office areas and control rooms to supply backup power to fire alarm systems and emergency egress lighting fixtures. In addition, uninterruptible power supplies will be used to provide backup power to communication systems and critical control systems to facilitate orderly shutdown of process equipment and to back up computers and control systems.

## 18.2.9 PORT SITE

### PORT FACILITIES

#### *Summary*

The Pebble Project will require developments at two waterfront locations approximately 60 - 65 miles from the mine site. These are Port Site 1, the permanent product loadout facility on Iniskin Bay, and Williamsport, the proposed site of the initial inbound logistics facility at the head of Iliamna Bay.

Port Site 1 is designed to accommodate the shipping of 1.1 million tons of concentrate per year in 28 vessels with a 36 hour berthing time. The port will also be capable of handling 50 Mgal of fuel per year, and 31 container barges per annum, hence will have attendant fuel storage and laydown areas.

#### *Port Site 1 Infrastructure*

#### Onshore Facilities

Port site facilities have been designed to enable a high degree of self-sufficiency, with maintenance and service equipment that reflect this consideration. Staffing levels required for port facility operations and maintenance is 48 people, with 35 onsite at any given time.

The following facilities will be provided at the port site:

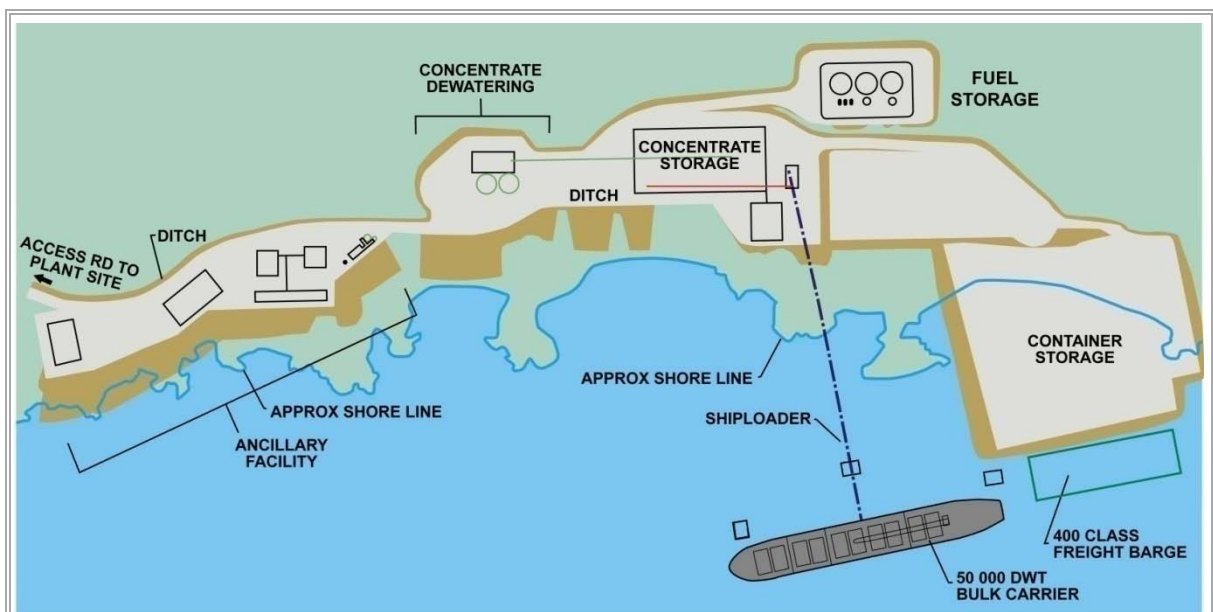
- Concentrate pipeline terminus – The concentrate pipeline terminus will consist of a choke station to dissipate energy from the concentrate pipeline; storage tanks for concentrate to feed the filter plant and for filtrate to return to the process plant; and a pump station to feed the filtrate return pipeline.
- Concentrate filtration – The concentrate slurry will be filtered to reduce the moisture content to levels acceptable for ocean shipping, with the filtered concentrate conveyed to the concentrate storage building.
- Concentrate storage building – This will be an un-insulated, steel-framed structure with the capacity to stockpile 130,000 tons of concentrate. This is equivalent to approximately one and a half months of concentrate production.

- Emergency diesel generation plant – The emergency diesel plant will consist of three 2 MW diesel generating units, which will allow for reclaim pumping, loadout facilities to avoid demurrage, camp and heating.
- Emergency vehicle garage – to house two fire trucks and an ambulance.
- Accommodations – The port facility will accommodate approximately 85 individuals in single-occupancy rooms once the port is under full-time operations. The facility will also provide office and conference room space.
- Incinerator – Solid waste will be stored in a fit-for-purpose facility.
- Potable/fire protection water treatment plant (WTP) –Potable water will be obtained from processed seawater using reverse osmosis (RO). The supply demand is based on 70 gal/d per person.
- 8 MW power generation plant.
- Fuel storage –Fuel storage will be provided in three 1.33 Mgal tanks contained within a 3.6 acre bermed containment.
- Helipad, repair facility, truckshop, warehouse, domestic sewage treatment plant (STP), storm water management system.

#### Port Site 1 Offshore Infrastructure

The offshore infrastructure plan provides for all required operations, including: barge cargo handling; deep draft concentrate vessel moorage; container storage; spill containment supplies; and equipment for the specified mining cases Figure 18.2.3.

**Figure 18.2.3 Port Site 1 Layout**



The layout incorporates the use of a steel sheet pile bulkhead. The northern section of the dock is intended to provide moorage space for supply barges and other small- to medium-size vessels. The southern section of the dock is intended to provide uplands area for the support of the concentrate conveyor and shiploader.

These design features have been sized to adequately serve the design vessels outlined in Table 18.2.6.

**Table 18.2.6 Design Vessel**

Parameter	Handymax Ship	Fuel Barge	Freight Barge
Deadweight Tonnage (long tons)	50,000	19,683	-
Length Overall (LOA) (ft)	685	512/605	400
Breadth (ft)	106	78	105
Depth (ft)	56	40	25
Draft (ft)	40	27.5	20

[Shiploader](#)

Material from the port site process facility will be delivered to the shiploader by conveyor. The shiploader will be positioned at the southern end of the bulkhead, near the face and will be designed for a 50,000 ton Handymax ship. The shiploader arm will be supported on a curved rail over a semi-circular series of piles. Vessels will thereby be held off the face of the dock. Mooring dolphins with connecting catwalks will provide moorage for the deep draft concentrate vessels.

*Construction Infrastructure at Williamsport*

[Site Conditions](#)

Williamsport is the initial Pebble Project beach landing from which all construction of the main access road will radiate. Williamsport is located near the head of Iliamna Bay at the end of a narrow, shallow, sometimes dredged-channel, approximately 6 miles northwest of Port Site 1 (at latitude 59°41'00"N and longitude 153°37'52"W). Williamsport is accessible by seaplane, boat or a State-maintained gravel access road to Pile Bay on Lake Iliamna.

Site characteristics in the Williamsport area are similar to those at Port Site 1, with low-lying brush and few spruce trees. The area enjoys protection from wave action but may be subject to more severe winter ice conditions than Port Site 1. Surface material in the intertidal area near Williamsport consists of silt with some gravel.

Figure 18.2.4 shows recent conditions at the existing Williamsport boat launch and dredged channel.

[Williamsport Infrastructure](#)

At the outset of project construction, a 65-person construction camp will be constructed at Williamsport to support the logistics effort underway prior to Port Site 1 completion, and to house construction crews building the access road in both directions from Williamsport. Additional infrastructure will include a storage facility, laydown yard, and diesel storage facilities.

Initial construction access will use shallow draft barges or hover barges, followed by dredging of the access channel and construction of an initial, temporary construction dock. Barges averaging 400 ton payload, with capacity to 700 tons, will use this temporary construction dock. Upon completion of the permanent barge dock facilities and the access road to Port site 1, scheduled to take about 18 months, the Williamsport construction dock will be reclaimed.

**Figure 18.2.4 Aerial Photo of Williamsport Boat Launch and Dredged Channel**



A 200 ft x 200 ft laydown area will be constructed immediately behind the Williamsport construction dock, which is initially connected with the mainland at the Williamsport landing by a 4,500 ft long, 18 ft wide gravel access road. This access road will later be incorporated into the permanent access road.

#### **18.2.10 MAIN ACCESS ROAD**

Development of the Pebble Project requires the construction of an all-weather, permanent access road between the mine and port sites to deliver materials and goods to the mine site.

Three short, isolated road systems exist in the project area today. The villages of Newhalen and Iliamna and the Iliamna airport are interconnected by a paved road system. The State of Alaska extended this road system north, along the east side of the Newhalen River, to connect to the village of Nondalton, but installation of a bridge across the river to complete the connection has been delayed. An existing State road also connects the village of Pile Bay to tidewater at Williamsport. Parts of this

road system will be improved to assist in project construction logistics. A short road system also connects the village of Pedro Bay with its nearby airstrip.

The proposed mine access road is 86 miles in length. The finished road will meet the project’s development and support needs over the proposed life of mine. The road design contemplates a two-lane (30 ft wide), all-weather, gravel-surface road capable of supporting all anticipated development and operational activities. The road will also provide a transportation link from the mine facilities to the existing Iliamna airfield.

Based on the proposed route, 20 bridges will be constructed over the length of the route with spans ranging from 40 to 600 ft. The route also includes a 1,880 ft causeway across the upper end of Iliamna Bay and approximately five miles of embankment construction along coastal sections in Iliamna Bay and Iniskin Bay.

Material sources for road embankment fill, road topping and rip-rap are available at regular intervals along the road route.

Approximately 80% of the alignment is on private land held by various corporate land owners, primarily Alaska Native Village Corporations. The remaining alignment is on land owned by the State of Alaska. The road route has been developed to avoid, to the extent possible, land parcels held by individuals.

The basic road route is illustrated in Figure 18.2.5.

**Figure 18.2.5 Pebble Project Access Route Map**



## GEOTECHNICAL CONDITIONS

A preliminary assessment of geotechnical conditions along the Pebble mine access road route has been completed based on field reconnaissance traverse, on foot, along the entire road route. The assessment includes review of topographic and geologic maps, aerial imagery and relevant regional reports. Essentially no invasive investigations have been completed along the road route.

The road route traverses terrain generally amenable to road development. The project area has a history of numerous glacial epochs that have been the primary force in creating terrain favourable for road development. In general, soils are good to excellent; where rock is encountered, it is fairly competent, useable for construction material and amenable to reasonable slope development. The numerous stream crossings appear to have favourable conditions for abutment foundations. There are no significant occurrences of permafrost or areas of extensive wetlands. Where the terrain is challenging, the rock or soil conditions are generally favourable. In intertidal areas, subsurface conditions appear favourable for placement of rock to create the required road embankment.

## NATURAL PHYSICAL CONDITIONS

The mine access road will traverse highly variable terrain as it progresses generally eastward from the mine site in the mountains north of Iliamna Lake to the Iniskin Bay port site on the North Pacific Coast. Over this route, the road alignment passes through three basic climatic zones with varied conditions.

The mine site end of the access road is at an elevation of 1,100 ft amsl. In general, the access route extends eastward through upland terrain to a crossing of the Newhalen River at a location seven miles north of Iliamna Lake. From the Newhalen River, the route continues over upland tundra terrain to the base of Roadhouse Mountain. Elevation along this road interval varies from 250 ft to 1,100 ft amsl. This western 26 miles of road alignment can be considered as typically “interior.”

For construction purposes, this region experiences climatic conditions similar to western interior Alaska. Precipitation is relatively light. Summers are mild and winter conditions are moderate by Alaska interior standards. Most of the west section of the alignment is dry open tundra with some areas of open or scattered scrub spruce and occasional birch. Being open terrain with commonly windy conditions, snow drifting is a factor. Whiteout conditions during winter wind storms or poor light/visibility periods can impact construction activities and transportation. Given that most of this portion of the alignment is through open terrain and avoids steep slopes, avalanche or rock slides are not an issue.

Other than the Newhalen River, stream crossings within this interval are minor and not subject to extreme high energy flow events. Ground conditions for road construction are considered excellent. Much of the route is over extensive glacial drift deposits consisting of gravel and sand with little fine soil cover. Suitable material sources are readily available at intervals along the alignment. Permafrost has not been noted as a significant occurrence at any location along the alignment.

From Roadhouse Mountain, the alignment continues east roughly paralleling the north shore of Iliamna Lake to the Iliamna River, a distance of 40 miles. This interval is more typical of a “transitional” environment, similar to conditions found at low elevations in upper Cook Inlet. The

elevation along this section of the alignment varies from 100 to 600 ft amsl. Snow cover has been observed to increase toward the east end of Iliamna Lake. A snow pack of 3 to 6 ft can be expected. Vegetation types also change to those more typical of a wetter and milder climate. Nearly the entire interval is forested with mature spruce, birch, and cottonwood, with a heavy understory of alder and other brush. It has also been observed that the extreme east end of Iliamna Lake is free of ice for a significantly longer period than the rest of the lake. The snow pack typically increases east of Pedro Bay. Most of the snowpack is melted off at lower elevations around Iliamna Lake by May. Ice can still be observed at stream crossing into the first half of May.

The road route north of Iliamna Lake is constrained to lower elevations near the lake due to steep mountainous terrain that typically rises rapidly from the lake shore to elevations of 3,000 to 4,000 ft amsl. Avalanche hazards exist in isolated locations along the alignment but routing has avoided any avalanche chutes and run-out areas. Because of the steep mountain slopes and lack of significant vegetation above 1,000 ft amsl elevation, storm runoff can rapidly accumulate and result in intense local runoff conditions. Areas along this interval of the access route noted to be particularly subject to this type of occurrence are the south slope of Knutson Mountain and the southeast slope of the mountain above Lonesome Bay and Pile Bay. Ground conditions, as they relate to road development, are typically excellent to fair.

Excellent conditions predominate over the outwash plain and ancient beach deposits west of Knutson Mountain. The terrain becomes much more rugged and variable to the east. Bedrock exposure is common, and rock excavation will be required in many areas. Mountain slopes at lower elevations typically shoulder varying depths of glacial till or other glacial drift deposits. Colluvium and relic scree are also evident along the road route. The soils tend to have a very high content of cobbles and large boulders. Typically the bedrock noted from Roadhouse Mountain to Iliamna River consisted primarily of intrusive rocks, such as quartz monzonite or quartz diorite, with lesser showings of tertiary volcanic rocks. In general the rock is fairly competent though typically fractured or sheared.

From the Iliamna River, the access road alignment continues east over Iliamna Pass to the Iniskin Bay port site, a distance of 20 miles. Over this short interval, the conditions transition to those typical of a 'maritime' environment. East of Iliamna Pass, the environmental conditions are classic North Pacific maritime. Iliamna Pass is the natural geographic passage through the Chigmit Mountains of the Aleutian Range to Iliamna Bay. The elevation along this section of the alignment varies from sea level to 900 ft amsl. Snow cover has been observed to increase toward Iliamna Pass. A snow pack of 4 to 10 ft can be expected. Vegetation types vary from that typical of the forested Iliamna Lake interval to alpine and barren coastal. West of Iliamna Pass, trees are sparse or void above 400 ft amsl. Along the coastal interval, trees are rare and vegetation consists mostly of dense alder thickets and tundra.

Upper Iliamna Bay is known to freeze over intermittently. Iniskin Bay can also freeze and develop an ice pack that may disperse rapidly during warm spells as aided by tide action and currents. Tidal variation along the coastal section is generally 12 to 14 ft, but tides can reach approximately 18 ft. Snow pack can vary dramatically at lower elevations along the coast. Heavy snows and high winds are common; however, warm spells can rapidly diminish the snow pack below 300 to 400 ft amsl elevation. The snow pack at Iliamna Pass and upper Williams Creek can be more than 10 ft and will typically remain into late May or early June. The existing road from Williamsport to Iliamna Lake can generally be cleared of snow by the first week of June.

Extreme winter weather conditions occur in the vicinity of Iliamna Pass. Heavy snow and high winds are common. Operations over this road interval will need to accommodate snow drifting, whiteout, avalanches and ice. Avalanche hazards exist at isolated locations along the alignment. Routing has been done to avoid apparent avalanche chutes and run-out areas. Due to steep mountain slopes and lack of significant vegetation, storm runoff can rapidly accumulate and result in intense local runoff conditions. Location of the alignment in the intertidal zone mitigates most of the recognized avalanche hazard and debris flow or land slide risk. Ground conditions, as they relate to road development are typically good to challenging.

Good conditions predominate on the ascent of Chinkelyes Creek Valley. The terrain becomes much more rugged and variable east of the crossing of Chinkelyes Creek. Bedrock exposure is common, and extensive rock excavation will be required in many areas. Mountain slopes at lower elevations typically shoulder varying depths of glacial till or other glacial drift deposits. Colluvium and relic scree are also evident along the road route. Typically, the bedrock noted east of the Iliamna Pass consists primarily of intrusive rocks, such as quartz monzonite, quartz diorite, or granodiorite. In general, all rock encountered is fairly competent, though typically fractured or sheared.

The access road and supporting facilities designs account for naturally occurring events in the project area, such as high-magnitude earthquakes and associated tsunamis, volcanic activity resulting in significant ash fall, and periodic high-intensity storms.

#### ROAD PURPOSE AND DESIGN CRITERIA

Design criteria for the main access road include:

- performance criteria
  - service type – private industrial road for mine development and operations support;
  - 50 year design life;
  - support 190 ton haul truck (CAT 785C) travel on road surface (empty) or CAT 777 loaded;
  - support freight transport consisting of a projected volume of 700,800 ton per year;
  - joint corridor with buried fuel line, concentrate slurry line, reclaim water line, and fibre optic cable;
  - location and routing to minimize development cost and provide for efficient long-term transport from port site to mine;
  - as far as practicable, minimize areas of disturbances;
  - as far as practicable, minimize specialty construction requirements;
  - as far as practicable, minimize stream crossings and avoid anadromous streams;
  - as far as practicable, route over lands with favourable ownership/management;
  - as far as practicable, route to avoid potential geologic hazards;
  - align for most favourable crossing approaches; and
  - optimize alignment for the best surface and subsurface soils and geotechnical conditions.



- physical construction criteria
  - maximum grades: 8.0%
  - road surface width: 30 ft
  - design speed:
    - moderate terrain: 35 to 45 mph
    - rough terrain: 25 mph
    - mountainous terrain: 15 mph
  - horizontal curve: 425 ft typical minimum with 200 ft permitted
  - minimum turning radius: 100 ft
  - vertical curve: American Association of State Highway and Transportation Officials (AASHTO) standard for design speed or specialized carrier requirements for oversize loads, K=20 typical & K=15 minimum
  - ditches: 2.5 ft typical minimum
  - cut or fill slopes: 0.25:1 to 3:1, depending on rock and soil type
  - minimum fill depth: 3 ft (varies with quality of subgrade)
  - road surfacing: 8 inch depth of crushed rock/gravel at -3 inches
  - culverts: corrugated metal pipe, 24-inch minimum with thaw pipes as needed and fish passage installation where required
  - guardrail: per criteria for industrial/resource road
  - bridges: two-lane, 32 ft deck, 200 tons capacity.

The design of the road horizontal and vertical alignments will be based on the AASHTO standards for alignment elements or as required for prescribed transport vehicle specifications.

## ROAD DESIGN

The road design criteria take into account the primary purpose of the road, which is to transport freight by mostly conventional highway tractors and trailers. However, critical elements of the design will be dictated by specific oversize and overweight loads associated with mine facility construction. It is anticipated that local communities and land owners will participate in management of road access. The design criteria also considers the need to use high-volume, efficient earthworks equipment. In addition, it has been determined that most of the large mine development equipment will be driven to the site from the port facility, thereby eliminating the need for assembly in the field. This will deliver significant cost and schedule benefits.

The road embankment design is dictated in part by the size and weight of vehicles and loads to be transported over the road. Mill and process facility component weights, as well as high axle loads associated with some of the selected mine equipment, have also been taken into account and typically control design.

The mine access road traverses varied terrain and subsurface soil conditions. This includes extensive areas of rock excavation in steep mountainous terrain, as well as several reaches of intertidal fill that will be subject to wave action and storm events. Given these conditions, road surface maintenance and embankment rehabilitation will be ongoing throughout mine operations, particularly over the first several years. The need for ready access to material sources to facilitate regular upgrading and maintenance has been taken into consideration. The typical road embankment design allows for efficient maintenance.

The concentrate slurry, reclaim water, and fuel pipelines running between the port site and the mine site have been incorporated into the road alignment. In general, the pipelines will be installed in a widened fill section at road intervals constructed as fill over poor soils. In areas of steep side-hill construction requiring rock excavation, or in areas of intertidal zone fill, the pipeline trench will be incorporated in the road embankment section. At all other intervals, the pipeline will be buried in a corridor developed adjacent to the road alignment.

The road design, including the placement and sizing of culverts, takes into consideration the seasonal drainage and spring runoff requirements for the route. Appropriate Best Management Practices (BMPs) will be utilized for the maintenance of the road during operations and construction.

#### BRIDGE DESIGN

River and stream crossing structures have been designed to provide a safe and efficient travel-way across existing drainages and topographic obstacles present within the proposed transportation corridor. These structures are intended to provide a reasonable level of service throughout the project design life, and to minimize the impact of the project on areas of sensitive habitat.

#### STRUCTURE CRITERIA

Structural elements, including foundation elements, will be designed to comply with existing Alaska Department of Transportation and Public Facilities (ADOT&PF) manuals and design specifications and with a Memorandum of Agreement between ADOT&PF and the Alaska Department of Fish and Game for the design of culverts for fish passage and habitat protection. Design conditions will include bridge grade and cross-slope requirements, environmental stresses (including temperature extremes, hydrology and hydraulics, ice conditions, seismic forces, and wind forces), vehicle operations and service life requirements.

Structures will be designed to accommodate two lanes of traffic with a single lane width of 12 ft and a shoulder width of 3 ft. Permanent structures will be designed for a service life of 50 years.

Permanent structural elements are assumed to be designed to support a range of design vehicles.

Several other considerations will be taken into account regarding the selection of materials and the design of crossing structures. The remote location and relatively short construction window, available for this project places additional emphasis on facilitating construction in the field and minimizing long-term maintenance requirements.

To optimize construction, individual components such as girders or deck panels will be designed as discrete, durable and readily transportable units that will allow for maximum shop fabrication and

minimal field construction. Field construction work will include welding, bolting, placing grout, installing temporary bracing and placing cast-in-place concrete.

Long-term maintenance requirements can be reduced by minimizing locations that impound water (or debris), paying attention to connection design, and the use of appropriate corrosion controls such as coatings and corrosion allowances

The conceptual bridge designs discussed in this report are based upon those currently in service in similar environments throughout the State of Alaska. These concepts should not be considered definitive, but do provide a reasonable technical basis for an order-of-magnitude cost estimate.

#### PERMANENT STRUCTURE TYPES AND APPLICATIONS

Two classes of structures are under consideration for water crossings: single-span bridges and multi-span bridges, along with several abutment types. The use of a structure at a specific site will be determined by hydrological considerations, local topography and fish passage requirements.

Bridges are assumed to be used at locations where culverts are not suitable. Structures such as multi-plate pipe arches and open pipe arches may be viable alternatives to short, single-span bridges; however, the site-specific information required to make this determination is not available at this time.

Bridge abutments are assumed to be similar for all bridge lengths and are assumed, for costing purposes, to consist of several driven steel piles, supporting a steel cap beam and surrounded by a fill embankment. The fill embankment will be armoured against erosion by one of several types of armour protection and will support the road approaches. Sheet pile abutments or armoured spill-through abutments, utilizing armour stone, are two of the available options. Several other abutment alternatives, such as rock-anchored piles, fabric-reinforced fill systems, or steel bin walls, may be required in areas where piles cannot be driven, due to shallow bedrock, large rubble, or woody debris, or where the alternate can be proven to be cost effective. The site-specific information required to make this determination is not available at this time.

Single-span bridges, from 40 to 60 ft in length (deck length), will be used as terrain requires. For costing purposes, single-span bridges are assumed to consist of multiple parallel steel box beams supporting a precast concrete deck. Multiple steel I beams supporting a precast concrete deck, or precast concrete bulb-t beams, will be similar in cost and construction methods. Span lengths have been assumed for costing purposes; each minor stream crossing design would be optimized for the specific site conditions as part of future detailed design.

Multi-span bridges will be used at major river crossings. Thirteen possible multi-span crossings have been identified, with the Newhalen River and the bridge across the tidal flats at Iliamna Bay, both being 600 ft. Construction is assumed to be similar to that of the single-span bridges, with multiple box girders up to 200 ft in length resting at the abutments and on in-stream piers as required. Each in-stream pier is assumed to be composed of several vertical driven-steel piles supporting a steel cap beam and, if required, one driven batter pile to act as an ice-breaker and debris rake on the upstream side. Span lengths and support conditions have been assumed for costing purposes; each major river crossing design will be optimized for the specific site conditions as part of future design.

Alternative long-span bridge types such as segmental concrete, truss, strand, cable stay, and suspension bridges are not considered in this study due to preliminary cost, constructability, and long-term maintenance concerns. Detailed analysis of this assumption will be undertaken as part of future design steps.

### 18.2.11 CONCENTRATE, RECLAIM WATER AND DIESEL SUPPLY PIPELINES

#### INTRODUCTION

This section presents the design basis and engineering for the concentrate, reclaim water, and diesel pipelines and pumping systems linking the Pebble mine site and port site facility. This includes the following:

- slurry pump station at the mine site;
- slurry pipeline from the mine site to the port site;
- terminal valve and choke station for the slurry system at the port site;
- return water pump station at the port site;
- return water pipeline from the port site to the mine site;
- diesel pump station at the port site; and
- diesel pipeline from the port site storage tank to the pump station site.

#### COMMON DESIGN CRITERIA

The pumping systems have been designed for operation 365 days per year, targeting 92% availability with an operating life of 25 years, thus requiring 100% standby capacity on the mainline pumps and other major process equipment items. The systems are designed to deliver 6% more flow than the maximum required by the process balance for both the concentrate and reclaim water pipelines and 8% more flow than the maximum required by the process balance for the diesel pipeline.

Pressures along the pipeline route have been predicted for a practical range of pipe sizes for the three pipeline systems. The required pipe wall thickness, flange ratings, and pumping requirements have been established and cost estimates developed for these results based on their 25-year life design life.

The concentrate and reclaim water systems are designed according to the latest edition of ASME code B31.11 “Slurry Transportation Piping Systems.” The diesel transfer pumping system is designed according to the latest edition of ASME B31.4 “Pipeline Transportation Systems for Liquid Hydrocarbons and Other Liquids.”

All pipelines will be constructed simultaneously in the same corridor.

The pipeline system design assumes the possibility of a one-week loss of electrical power.

#### PUMP STATION DESIGN

A typical pump station layout is shown in Figure 18.2.6.

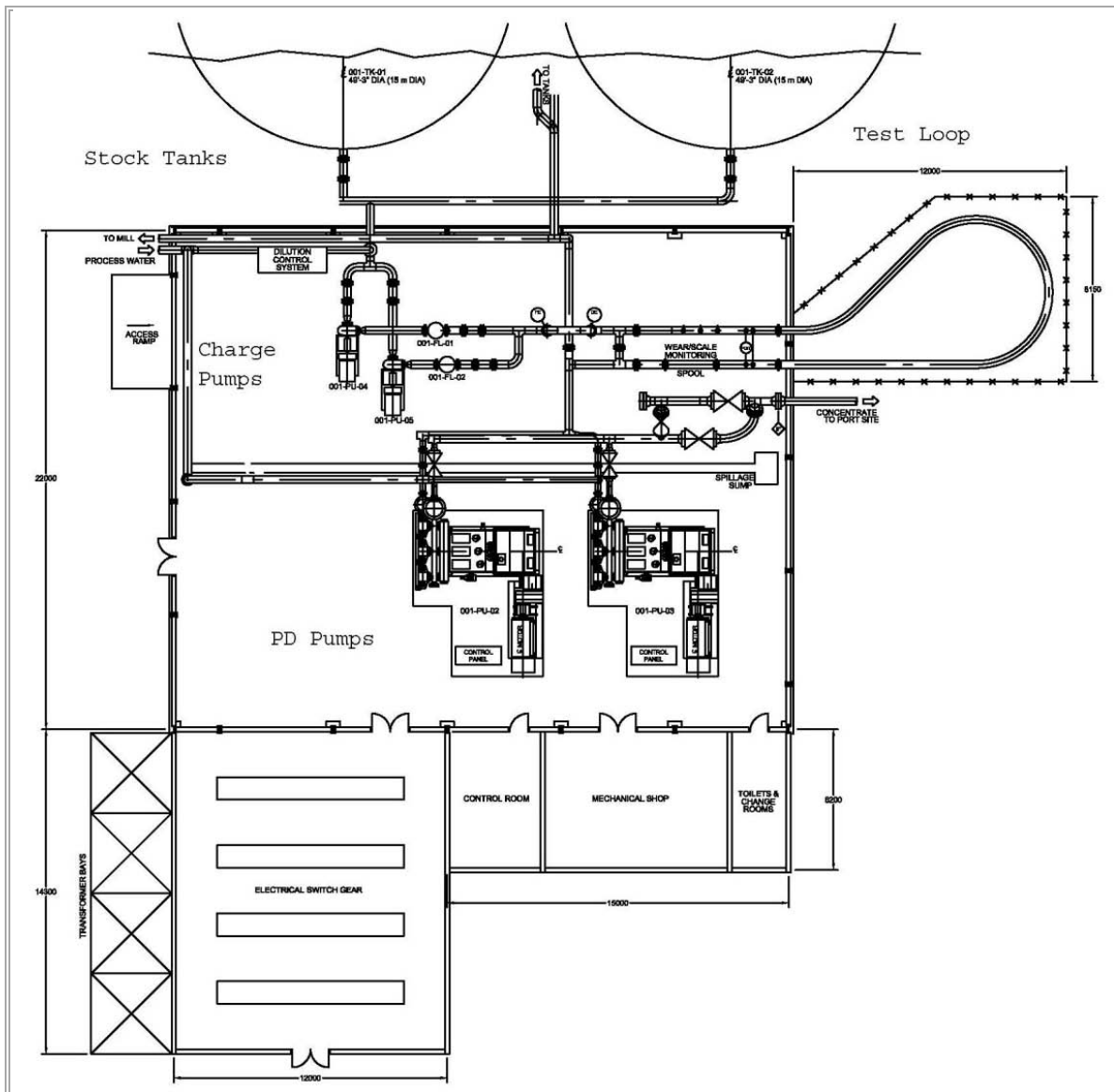
**CONCENTRATE STOCK TANKS**

Two agitated concentrate stock tanks are provided as a buffer between the concentrator and the pumping/pipeline system. The stock tanks have sufficient capacity to provide 16 hours of storage capacity at the maximum production tonnage. The tanks are lined to protect against wear and corrosion.

**PUMP STATION BUILDING**

The pump station building will house the centrifugal charge pumps, the test loop and associated instrumentation, the mainline positive displacement pumps, the pig launcher, and associated general station piping.

**Figure 18.2.6 Pump Station Layout**



## MAJOR MECHANICAL EQUIPMENT

### *Charge Pumps*

Charge pumps are used to provide appropriate suction-side pressure at the mainline positive displacement pumps. The charge pumps (one operating, one standby) are driven by variable-frequency drives (VFDs) to allow for adjustment of the mainline pump charge pressure and for variation of the flow through the test loop when the flow is being diverted back into the stock tanks or concentrator.

The charge pumps need gland flushing water, which is supplied from the plant seal water supply.

### *Mainline Pumps*

Two positive displacement (PD) pumps are installed for the slurry line. Although more expensive than simple piston pumps, the diaphragm arrangement, which provides a barrier between the slurry and the pistons, will improve reliability and reduce down-time for maintenance. The pumps are driven by VFDs to provide precise control over the pumping rate and pipeline start-up and shut-down.

## SLURRY PIPELINE DESIGN

### *Steel Grade, Pipe Size, Wall Thickness, and Flange Rating*

The pipe is 8 inches, based on the required flow and pressures. The wall thickness is reduced along the length of the line as allowed by the local line pressure. The wall thickness is limited to a minimum of 0.219 inches to make it strong enough to avoid damage during construction.

The pipeline will be of continuously welded construction, with flanges provided only as required for installation of the liner and installation of valves. The flange rating is reduced along the length of the line as allowed by the local line pressure. Flanges are Class 1,500 and Class 900 ASME B16.5.

### *Internal Lining*

A 7.2 mm HDPE lining is required for this system, based on the abrasiveness and corrosiveness of the concentrate slurry for the design mine life of 25 years. The liner is installed into the continuously welded line in the field in 1,500 to 3,000 ft lengths. Flange joints will be used to repair the breaks in the line necessary for installation of the liner.

## CHOKE STATION

A choke station that raises the hydraulic grade by 328 ft will be installed at the port terminal to maintain the hydraulic grade line at least 60 ft above the pipeline profile at all points along the route. This will ensure slack flow will not occur at local high points near the terminal unless a choke station is provided<sup>9</sup>.

### *Return Water Pipeline Design*

Steel grade API 5L X35 will be used in the return water pipeline design. The pipe is 7 inches, the most appropriate size for the required flow and pressures. The wall thickness is reduced along the length of

the line as allowed by the local line pressure. The wall thickness is limited to a minimum of 0.219 inches to make it strong enough to avoid damage during construction.

The pipeline will be of continuously welded construction, with flanges provided only as required for installation of the liner (as per the concentrate pipeline) and of valves. The flange rating is reduced along the length of the line as allowed by the local line pressure. Flanges are Class 900, 600 and 300 ASME B16.5.

**DIESEL PIPELINE DESIGN**

Steel grade API 5L X65 of standard pipe dimensions will be used in the diesel pipeline design (to dimensional tolerances as defined in ASME code B36.10). The 5-inch pipe has an external diameter of 5.563 inches. The wall thickness is reduced along the length of the line as allowed by the local line pressure. The wall thickness is limited to a minimum of 0.218 inches to make it strong enough to avoid damage during construction.

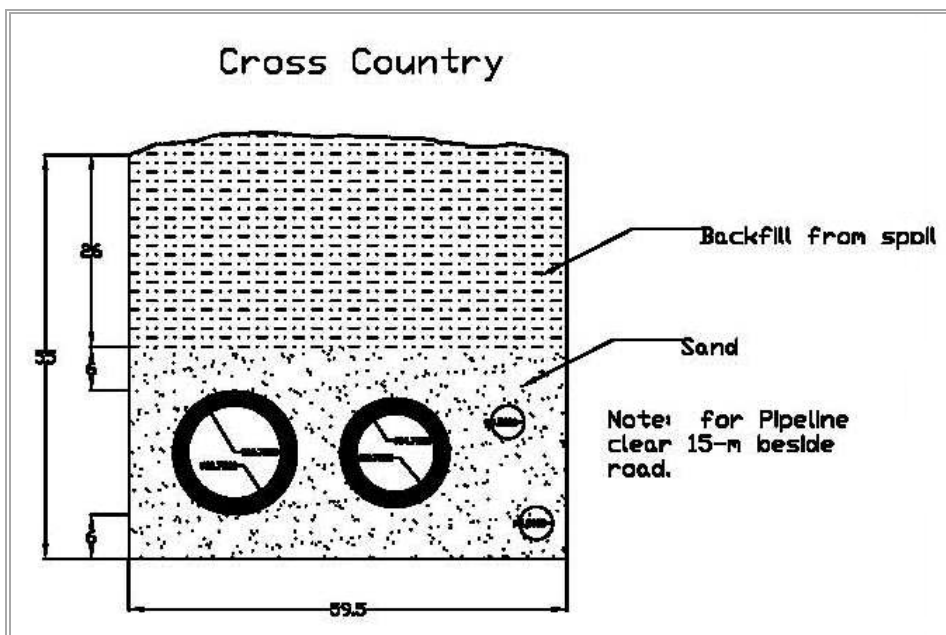
The pipeline will be of continuously welded construction, with flanges provided only as required for installation of valves. The flange rating is reduced along the length of the line as allowed by the local line pressure. Flanges used are Class 900, 600, and 300 ASME B16.5.

**PIPELINE CONSTRUCTION AND INSTALLATION**

*Trench and Crossings*

The pipeline right-of-way route is approximately 86 miles long. The pipelines will be buried in a common ditch (Figure 18.2.7) except at major bridge crossings over rivers and creeks. Common resources will be utilized for construction activities.

**Figure 18.2.7 Pipeline Trench Section**



### *Water Crossings*

Crossings will be bored under rivers and streams so as to minimize any impact on the waterways. At longer crossings, the lines will be supported on the road bridge. Any pipeline sections not buried underground will be encased in a protective layer. For the port approach through Iliamna Bay, and for sections where the road is excavated through rock, the pipelines will share the right of way in a common ditch excavated at the shoulder of the road prism.

### *Freeze Protection*

Given the low atmospheric temperatures in winter, the pipelines must be protected from the possibility of freezing during pump shutdown. Several methods of freeze protection have been considered. A cost analysis has been performed to compare a heating system with burying the pipelines below the frost depth (11 ft) or insulating them.

The selected freeze protection method is a combination of insulation and burial to 5 ft below ground surface. This provides a period of 72 hours after pump shutdown, at  $-47^{\circ}\text{F}$ , before the outer surface of the pipe cools to  $32.9^{\circ}\text{F}$ . This timeframe is considered sufficient to repair pumps and ensure that freezing does not occur.

### *Cathodic Protection*

A cathodic protection system has been included to protect against external corrosion in the event of damage to the external coatings on the pipes.

### *Leak Detection System*

An allowance has been made for a leak detection system, which will monitor and alert operations in the event of a pipeline leak. The system requires that pressure transmitters be located along the pipeline route. This will also assist in the detection and prevention of slack flow in the pipelines.

### *SCADA*

A SCADA system has been included for monitoring and control of the pumping facilities. The system will also include fibre-optic communications between the concentrator and port site. The fibre-optic line will be buried in the pipeline trench alongside the pipelines. Other instruments located along the pipeline route, such as pressure and temperature transducers, will be tied into the fibre-optic link.

### *Valves*

As required by the pipeline design code, manual isolation valves are provided on either side of “major” river crossings. Valves are Class 1,500, Class 900, Class 600, and Class 300, depending on the location along the pipeline route.



## 18.2.12 VEHICLE MAINTENANCE

### GENERAL

The Truck Shop complex at the Pebble mine site will consist of a 500 ft long x 160 ft wide structural steel, pre-engineered building designed to accommodate the required facilities for repair, maintenance, and rebuilding of both the open pit mining equipment and light vehicles. The facility will also house storage space for spare parts and consumables, and offices for the pit supervisors, mine engineers and planning staff. Change facilities will be provided for the mine personnel.

This complex will be located east of the process facilities and adjacent to additional maintenance and storage buildings, such as the fuel storage compound and dedicated warehouse. The building will be clad with insulated profiled steel cladding and founded on spread footings on rock.

The total useable ground floor area of the building will be 80,000 ft<sup>2</sup>, including 64,000 ft<sup>2</sup> for service bays and shops, 3,500 ft<sup>2</sup> for change facilities and 12,500 ft<sup>2</sup> for the lower floor of the shops warehouse. The total useable second floor area of the building will be 8,000 ft<sup>2</sup> for a small parts warehouse and the services room. The total useable third floor area of the building will be 16,000 ft<sup>2</sup> for offices for the pit supervisors, as well as mine engineering and planning staff.

### SERVICE BAYS

The service bays consist of the following:

- heavy vehicle repair bays;
- heavy vehicle tire repair bay;
- light vehicle service bay; and
- welding bay.

All service bays except those for light vehicle repair and welding will have cast rails embedded in the floor for protection when repairing tracked dozers and auxiliary equipment. The truckshop will be equipped with two 50/5 ton overhead cranes that will provide service to both the heavy and light vehicle repair bays.

### HEAVY VEHICLE REPAIR BAY

Seven bays will be designated for the service and repair of major mining equipment. The facilities will include automatic hose reels for dispensing engine oil, transmission fluid, hydraulic oil, air, solvent, diluted coolant and grease. Hose reels will be serviced by delivery pumps located in the lubrication storage building. Waste lubricant recovery systems will pump used oil and coolant to holding tanks located at the lubrication storage building for recycling or disposal. The drive through bays will be 50 ft wide, 80 ft long and provide for the full dump height of a 400 ton capacity haul truck.

### TIRE REPAIR BAY

One bay, 50 ft wide x 80 ft long, will be dedicated to replacing tires on the haulage trucks and other large mining equipment.

### LIGHT VEHICLE SERVICE BAY

Two bays, 50 ft wide x 80 ft long, will be used for servicing light vehicles, including vehicle maintenance and tire changes. All small equipment, such as air tools and others required for wheel alignment, balancing, automotive testing and diagnostic purposes will be available in this bay.

### WELDING BAY

A bay, 50 ft wide x 80 ft long, will be provided for welding work. Ventilation fans and flash shields will be provided for personnel protection.

### SERVICE SUPPORT FACILITIES

Other support facilities and shops for maintenance and repair will include the following:

- ready lines;
- lubricant storage building;
- machine shop/plate shop;
- electrical/instrument repair facilities; and
- compressor room.

### READY LINE

A ready line outside the truckshop complex will provide parking for at least 24 mine mobile equipment units awaiting service or repairs.

### LUBRICANT STORAGE AREA

The lubricant storage area will house tanks for an approximately one-month supply of lubricants, coolants, and waste oil for the mining and plant support equipment fleet. The building will be 75 ft long x 63 ft wide x 27 ft high and will be located about 160 ft from the truckshop. The separation distance allows for the construction of two additional service bays, if required in future, and provides fire safety separation between the two buildings. A separate bermed exterior storage facility will be provided for waste oil and spent coolants. The lubricant storage building will be furnished with loading/unloading arms and pumps.

This building will also contain air-operated transfer pumps for supplying lubricants to the truckshop dispensing reels in the service bays. A pipe rack will connect the truckshop to the lubricant storage building.

### MACHINE SHOP / PLATE SHOP

A machine shop and a plate shop will be located at the south end of the truckshop. These shops will be outfitted with machine tool and cutting equipment.

## ELECTRICAL / INSTRUMENT REPAIR FACILITIES

An electrical and instrumentation shop in the truckshop will be outfitted with maintenance and test equipment.

## COMPRESSOR ROOM

A compressor room adjacent to the machine and plate shops will house compressors and air dryers to supply mill and instrument air to the facilities within the truckshop.

## WAREHOUSE

The warehouse integrated into the truckshop will house materials, service parts and supplies for mine mobile equipment maintenance. The warehouse will have an area of 12,500 ft<sup>2</sup> on the ground floor and 2000 ft<sup>2</sup> of mezzanine space. The warehouse will be serviced by electric forklifts.

## CHANGE FACILITIES

Change facilities, complete with lockers, showers and washroom facilities, will be provided for the pit and truck shop crews. It will be located on the ground floor.

## OFFICES

Offices occupying an area for 16,000 ft<sup>2</sup> will be located on the third floor of the truckshop complex for the pit supervisors, as well as mine engineering and planning staff. A lunchroom equipped with fridge, stove, microwave, dishwasher, and cupboards will also be on the ground floor.

Offices for all other staff and a control room will be provided in the process plant building.

### 18.2.13 ADMINISTRATION BUILDING

#### SUMMARY

The administration building at the mine site will be a two storey, pre-engineered building, 58 ft wide x 175 ft long. It will be located adjacent to and connected with the permanent camp complex via an arctic-type corridor. A total of 83 offices and cubicles will be provided for mine management and supervisory staff, as well as for human resources, accounting, procurement, information technology and safety staff. The ground floor will include a lunch room, training room and 32 offices, including 10 open cubicles and 22 closed offices. The second floor will provide for 51 offices, including 18 open cubicles and 22 closed offices. The building will be clad with insulated profiled steel cladding and founded on spread footings on soil.

#### ADMINISTRATION/ LAB

Administration offices will be within the process building and occupy a total floor area 25 ft wide x 232 ft long on two floors. The space will include 23 offices, two conference rooms, a lunch room, open working areas and washroom facilities.

## GATEHOUSE AND SECURITY

The gatehouse will be a rectangular, single storey, pre-engineered building, 26 ft wide x 50 ft long x 10 ft high, with a gross floor area equal to 1,300 ft<sup>2</sup> and will provide a security checkpoint for all incoming and outgoing traffic to the process and mill site.

The building will be clad with insulated profiled steel cladding and founded on spread footings on soil and will be located at the termination of the access road prior to its division into mill and truck shop access roads. A total of four offices and cubicles will be provided, together with a security room, open working area and washroom facilities.

## OFFSITE OFFICES AND FACILITIES

### *Office Facilities*

The Pebble Partnership will operate an office in Anchorage that provides coordination with the Alaska government and local Alaska suppliers, oversees the concentrate marketing activities, and acts as the recruiting office for mine personnel.

The Pebble Partnership and the engineering contractor will work in a combined project office facility during the engineering, procurement and construction management (EPCM) phase of the project. This office will be separate from the permanent Pebble Partnership office in Anchorage and will be closed at the end of the construction. The location of this office is expected to depend upon the EPCM contractor selected.

### *Logistics Facilities*

The majority of non-perishable goods trans-shipped to the port site will be delivered to a large cargo handling facility in Washington State. Containers and bulk goods will be loaded on ocean barges and hauled by tug to the port site.

Personnel flying into and out of Iliamna will use public passenger handling facilities at the respective airports. Air transport contractors will operate, maintain, and (if necessary) build these facilities as part of their service.

## **18.2.14 CONSTRUCTION (CAMP, POWER, WATER AND SEWAGE)**

### CAMP DESIGN

The first camp to be constructed at the mine site will be a 250-person fabric-type for use during early site construction activities and throughout the construction phase as required for seasonal peak overflows. The permanent camp will be built for and used during the construction phase in a double-occupancy configuration to accommodate 2,150 workers, and will later be upgraded to single-occupancy rooms for the operations phase. The permanent camp will have 1,150 single-occupancy rooms.

### *Features of the Camp Design*

All camps will be constructed of modular units manufactured off site in compliance with highway size restrictions for transportation. The modular units will be transported, assembled and completed at the project site. The camps will have separate areas for dormitories and a central services core.

The dormitory modules will be connected with field-constructed, or prefabricated, fire-rated egress corridors and modularized fire-rated enclosed stairwells at each end complying with all building and fire code requirements.

The central services facility will be designed and pre-fabricated as a single-storey modularized unit, fully equipped for food preparation/storage, kitchen, dining room, an incinerator and recreation areas. All facilities, including the kitchen, will be sized and built for the highest design population when.

The camp will include dormitories, kitchen and dining facilities, incinerator, recreation facilities, check-in and check-out areas, administrative offices and first aid facilities.

### *Accommodations Criteria*

The basic design criteria for the camp are as follows:

- The site will be levelled, ready for installation of trailers;
- The camp heating, hot water and kitchen appliances will be electric;
- The camp will be provided with sprinklers throughout;
- Arctic corridors will be provided to connect the dormitories with the rest of facility;
- The quality level of the facilities will be 'superior';
- Camp facilities will be handicapped accessible; and
- The camp will be complete with all electrical, communication, lighting, mechanical, sprinklers, plumbing equipment and fixtures, all finishes, furniture and related items ready for occupancy.

### *Dormitories*

- The dormitories will consist of six wings, three stories in height;
- The room distribution will be as follow:
  - 515 single bed rooms (occupants to share centrally located washroom cubicles)
  - four barrier-free bed rooms (two contiguous bedrooms to share a bathroom)
  - 16 rooms with double sized bed for married couples (married couples to use centrally located washroom cubicles)
  - six manager rooms (managers to use centrally located washroom cubicles);
- Handicapped, married couples and manager rooms will all be the same size;
- Handicapped rooms will be located on the ground floor of wings;

- Dormitory wings, in addition to washroom cubicles, will have laundry, housekeeping and luggage storage rooms on each floor; and
- A dormitory wing, or individual floors within a wing, will be dedicated for female occupants.

#### *Dining and Kitchen Facilities*

- The kitchen will be sized for intended dormitory occupancy number;
- The dining facility to be sized for 275 meals per sitting, two sittings per meal;
- Food storage capacity will be provided to allow for twice a month food delivery;
- Provide garbage storage and incinerator. Incinerator to be operated once a day; and
- All kitchen equipment will be electric.

#### *Recreation Facilities*

- Recreation facilities, including a gymnasium for playing basketball (half court size);
- The recreation room, with ping pong tables, pool tables, foosball tables and other games;
- Smoking and non-smoking TV viewing rooms will be provided; and
- A weightlifting and exercise room, equipped with weight lifting equipment, treadmills, stationary bicycles and rowing machines.

#### *Other Facilities*

- Commissary with post office and administration office;
- Computer area for 20 computer stations;
- Main first aid station where patients can be stabilized for evacuation to an off-site hospital;
- Check-in and check-out facilities, including the administrative and catering offices for the complex; and
- Arctic corridors as required to connect all the camp facilities.

#### **18.2.15 MAIN WAREHOUSE**

The warehouse will be a rectangular, single-storey, pre-engineered building, 100 ft wide x 225 ft long x 23.5 ft high with a gross floor area of 22,500 ft<sup>2</sup>. An 80 ft x 80 ft mezzanine floor will be used for three offices, a filing/storage area, a washroom and an entrance corridor. A fenced yard, 60 ft x 226 ft, with two truck gates and one man gate will be provided on the north side of the process building.

#### **18.2.16 MILL SHOPS**

This building will be T-shaped, pre-engineered, insulated, steel-framed and steel-clad, founded on spread footings. The plan area is 61,500 ft<sup>2</sup>.

### 18.2.17 MEDICAL/FIRST AID

First aid posts will be provided at the Accommodations camp as well as the truckshop, process plant and the port. A full time nurse will be in attendance at the first aid station at the camp and roaming first aid attendants/security staff will patrol the property.

Two ambulances and a fire truck will be located at the mine site and at the port. A sprung structure, three bay garage for the emergency vehicles will be located near the respective gatehouses. Patients requiring evacuation will be driven by ambulance to the clinic at Iliamna or flown from Iliamna to hospitals in Anchorage.

### 18.2.18 COLD STORAGE BUILDING

Cold storage buildings will be designed as single storey, sprung structures, 75 ft wide x 150 ft long x 23.5 ft high with a gross floor area equal to 11,250 ft<sup>2</sup>. Two buildings are required, one adjacent to the truckshop and one near the mill shops. These buildings will be insulated and unheated. The cold storage buildings will be used for the short and long term storage of consumables requiring protection from the elements, but not requiring the maintenance of a mean temperature above freezing. The buildings will be supplied with light vehicle truck access doors at each end, as well as accompanying main access doors adjacent to the vehicle doors. The buildings will be provided with interior and exterior lighting.

### 18.2.19 UTILIDORS

Primary process and infrastructure facilities at the site will be connected via utilidors. These utilidors will be elevated steel structures providing a means of routing both personnel and essential services (glycol, water, etc) to each facility that is environmentally controlled. Support towers for the utilidors will double as emergency exits, and bus shelters as exit stairwells will be provided to exit personnel to grade. The utilidors will be nominally 12 ft high x 10 ft wide and be fully clad, insulated and heated.

### 18.2.20 WATER SYSTEMS

#### FRESH WATER

Fresh water will be collected from groundwater sources (wells). Fresh water supply will be piped to the filtered water tank located on the west side of the mill building, adjacent to the mill flotation area. Water from the sand filters will also be added to this tank. From the filtered water tanks, most of the water will be pumped to the clean service/firewater tank located in the same area and the balance will be used as cooling water for the grinding mills. From the clean service/firewater tank the fresh/filtered water for use as process water, will be distributed via underground pipelines to the process plant and the primary crusher raw water tank, and the open pit mine water tank at the primary crusher. The firewater will be distributed as detailed below.

#### PROCESS WATER DISTRIBUTION

Process water will be a combination of surface water catchments and tailings reclaim water. Process water will be pumped from the tailings pond and various collection sumps to the two process water

ponds located on the south side of the process plant. Process water will be pumped from the process water pump house and distributed via overland pipelines to the various areas of the process plant. In addition, fresh water added to the system via the clean service/firewater tank will be distributed via underground pipelines to the process plant and primary crusher area as described above.

The process water ponds will comprise two HDPE lined ponds designed to store 2,000,000 ft<sup>3</sup> of water. The two ponds complete with a central divider dyke will occupy a plan area of approximately 11 acres<sup>11</sup>. The total height of the containment dykes will be 17 ft, allowing for a water depth of 8 ft, plus an allowance of 6 ft for an ice sheet, plus 3 ft of freeboard. A process water pump house will be located mid-way along the divider dyke. The pump house will comprise a rectangular concrete sump/sub structure, approximately 48 ft long x 20 wide x 12 ft deep, with a prefabricated, skid mounted pump house mounted above, complete with six 1750 hp vertical water intake pumps.

#### FIRE WATER

The clean service / firewater tank located at the mill will have a reserve in the lower portion of the tank that will be drawn from below the primary water nozzles. The fire-fighting reserve in each tank will meet a two-hour demand at 1,500 USgpm. Firewater pump skids complete with diesel-driven fire pump, jockey pump and controls will be installed. Dedicated fire mains complete with hydrants will be provided at the process plant and ancillary buildings, the camp, truckshop and the primary crushers. Fire extinguishers will also be provided throughout the facilities. Fire hose reels and cabinets will be installed throughout the process plant building and truck shop. Sprinkler systems will be installed in the warehouse, the main office and the truckshop.

Fire alarm systems at the warehouse and truckshop will report to the plant control room or to the main gatehouse, both of which will be manned 24 hours a day.

#### POTABLE WATER – MINE SITE

Potable water at the mine site will be supplied from wells located north of the open pit. The water will be pumped to the potable water treatment plant, potable water tank and potable water pump house at the mill and then distributed to the various facilities, including the camp, administration building, warehouse, gatehouse, truck shop and process buildings.

### 18.2.21 SOLID WASTE DISPOSAL

#### HAZARDOUS WASTES

As part of the overall plant design, all hazardous wastes outside of tailings and waste rock will be segregated at the point of generation, placed into appropriate storage containers and shipped off site to an appropriate recycling or disposal facility. A lined storage facility will be constructed within or near the site fuel storage facilities to store the hazardous waste held in segregation pending periodic off-site shipment. Specific hazardous waste handling protocols are:

- Waste Oil – waste oil from heavy equipment and stationary milling equipment will be transferred to a waste oil storage tank to be located within the lubrication storage facility. The waste oil will be filtered and burned in a packaged waste oil burner unit to generate



supplemental heating for the truck maintenance shop in the winter months. Any excess waste oil not consumed in this manner will be shipped off site using a licensed waste oil disposal firm for recycling. Every attempt will be made to dispose of waste oil on site as a supplemental heat supply.

- Waste antifreeze, solvents and grease – waste antifreeze, solvent and grease will be collected and stored in appropriate drums for regular shipment off site to a licensed recycle or disposal facility.
- Waste batteries – waste vehicle batteries will be collected, placed on pallets for regular shipment off site for disposal at a battery recycling facility.
- Tires – old tires will be collected and those not used on site to provide vehicle protection barriers will be disposed of through burial within an active section of the tailings impoundment.
- Hydrocarbon Contaminated Soil – a landfarm will be constructed utilizing bio-remediation to treat petroleum contaminated soil that may accrue during the mine's operational life. The landfarm will be constructed near the proposed non-hazardous waste on-site landfill. The landfarm will be constructed on a compacted till or other suitable liner. Hydrocarbon contaminated soil will be transferred into the landfarm, spread out over the surface in thin lifts and treated with fertilizer to promote bio-remediation. Soils will be routinely turned over and sampled until it can be demonstrated that the hydrocarbon contamination has been reduced to acceptable standards. Clean soils will be stockpiled for use in progressive reclamation projects. Water collected within the landfarm will be run through an oil-water separator with the clean water discharged into the tailings impoundment.

#### NON-HAZARDOUS WASTES

Non-hazardous waste will be segregated into the following two streams:

- Putrescible kitchen wastes – organic food wastes from kitchen facilities will be segregated and burned daily in on-site incinerators to help limit wildlife attraction associated with disposal of food wastes;
- Non-putrescible waste – all other non-hazardous, non-organic garbage will be collected and disposed off within an on-site landfill to be located in a suitable area that drains by gravity into the tailings impoundment. Non-hazardous garbage placed within this landfill will be periodically buried under a layer of soil or NAG waste rock to prevent loss of garbage through wind action and to control drainage.
- Construction, operation and closure wastes will likely be managed under one waste management permit.

## 18.2.22 COMMUNICATIONS

### GENERAL

The mine site will be connected to external networks via the fibre-optic line contained in the concentrate pipeline trench and the power transmission system connected to the Kenai Peninsula. A backup satellite system rated to handle the full information bandwidth will also be installed.

A communications network will be established utilizing fibre-optic technology and wireless communication for voice, fax, Internet, and PC network traffic. The communications and IT infrastructure will include internet gateway, telephone private branch exchange (PBX) system, Ethernet local area network (LAN), IT servers, desktop computers, UPS system, copper and fibre cabling, and site VHF radio system.

Voice communications will be based on an IP network using wide area network (WAN) links, which will result in lower operating costs compared to other solutions. A VHF radio system will be installed with provision for handheld units, mobile units and base stations. A mobile phone cellular service will be included in the system. A telephone PBX system will be provided for telephone communications using analog wiring. Video conferencing systems by WAN links will be provided complete with messenger service flat screens and a projector for use in meeting rooms. A base station and client station will be provided for wireless connection to the network system. The system will include a smart card device and smart access card to enable secure smart card logon to the network for desktop and laptop users.

The LAN system will utilize switches to connect to users' computers, and the WAN system will use routers with multi protocol label switching (MPLS) capabilities to support voice and high bandwidth capabilities.

## 18.2.23 UTILITIES AND SERVICES

### HEATING, VENTILATION, AND DUST CONTROL HEATING

#### *Summary*

Heating for buildings and facilities at the mine site will be provided primarily by heat recovery from the combined-cycle natural gas-fired gas turbine (CCGT) power plant. Waste heat from the power plant will be transferred via a glycol circulating system throughout the plant site and truckshop areas by transfer pumps. A boiler adjacent to the mill building will be used as a backup heat source when required.

Each building/area requiring heat will be equipped with a secondary glycol loop supplied by the primary loop. Secondary loop circulating pumps provide the method of transfer. Glycol unit heaters will be placed strategically around the perimeter and interior spaces of the buildings as required. Localized controls will provide climatic control for the unit heaters

Remote buildings that are relatively small, such as small warehouses, and gatehouses, will be heated with electric heaters.

## VENTILATION

Continuous ventilation will be provided for all personnel-occupied and selected unoccupied spaces. Ventilation rates will vary depending on the level of occupancy and the intended use of the space as per ASHRAE, OSHA, and State of Alaska building code and standards.

Ventilation systems will include make-up air units for continuous supply of tempered air, general exhaust fans for contaminant removal, and localized exhaust fans to remove contaminants directly where appropriate. Glycol supply to the make-up air units will be the primary heat supply source.

## DUST AND FUME CONTROL

Efficient dust control has been recognized as fundamental to the plant design in minimizing the amount of airborne particulate matter that is introduced to the surrounding environment.

Dust control systems will include hoods, ductwork, dry baghouse-style dust collectors and/or wet scrubbers, and enclosures designed to capture fugitive dust or fume emissions at source. These systems will be designed and selected to reduce particulate emissions to meet applicable air quality regulations.

Remote control points, such as overland conveyor transfer points and crushers where water is in short supply, will use dry cartridge-type dust collectors to capture dust and periodically return it to the conveyor belts in the process areas.

Dust collection within the process buildings, such as the coarse ore storage reclaim area and pebble crushers, will use wet scrubbers to collect airborne dust. This will form a dust slurry that will be collected and pumped back to the process.



## 18.3 TAILINGS, WASTE ROCK AND WATER MANAGEMENT

---

### 18.3.1 INTRODUCTION

This section presents an overview of the tailings storage facility (TSF), waste rock storage, and waste and tailings management as developed for the development cases presented in this Preliminary Assessment.

The level of study that has been prepared for the proposed Site G TSF is comprehensive in terms of both the site investigation and the design effort. The TSF design and mine waste rock storage concept form a basis for the safe, long-term storage of all tailings and mine waste rock for the 25-year IDC Case (IDC).

The Site G TSF, as designed, has sufficient capacity to accommodate all tailings from the initial 25 years of mining. Studies relating to the investigation, selection and design of additional tailings storage facilities to accommodate the 45-year Reference Case and the 78-year Resource Case have been ongoing for some time. Some aspects of these studies (e.g. evaluation of overall Pebble Project area) have been evaluated over a period of 6 years. The large land package surrounding the Pebble deposit presents a number of potentially viable locations for additional TSF sites, subject to further design effort within the environmental risk mitigation framework.

Two separately-managed tailings streams will be deposited concurrently into the TSF. Benign tailings from the rougher flotation circuit (bulk tailings) represent one stream, and pyrite-rich tailings generated from the second cleaner scavenger circuit represent the other. The cleaner scavenger tailings will be deposited sub-aqueously to preclude oxidation and the potential generation of acidic conditions.

Waste rock, both potentially acid-generating (PAG) and non-potentially acid-generating (NAG) will be stored in pit-rim waste dumps. PAG waste rock will be managed in a separate facility to allow for reclamation of the PAG material at closure.

### 18.3.2 SITE CHARACTERIZATION

The preliminary layout of mine site facilities incorporating the Site G TSF is shown in Figure 18.3.3. The TSF will be contained within northern, eastern, and southern embankments. The elevation of the Site G valley ranges from approximately 1,200 ft to over 2,000 ft. The waste rock dumps will be situated on the pit perimeter to the northeast, southeast and southwest.

#### GEOTECHNICAL PROFILE

Geotechnical conditions in the TSF and related open pit and waste rock dump areas can be summarized as follows.

#### *TSF Area*

Overburden within in the TSF typically comprises sand and gravel with varying amounts of silt, and varies in depth from near surface to approximately 65 ft. It is thickest in the valley bottom. Some

localized areas exist in the valley bottom with peat thicknesses to 10 ft. Overburden at the higher elevations is mainly colluvium and glacial drift material consisting of sand and gravel with varying amounts of silt; the overburden thickness varies to a maximum depth of approximately 20 ft.

The bedrock is typically highly weathered & frost-heaved near surface, becoming more competent with depth. Bedrock in the northern embankment area consists mainly of granodiorite/monzonite and zones of basalt, with pyroxenite and siltstone on the northwest slopes. Bedrock in the valley of the northwest area consists of basalt, gabbro, and granodiorite. The rock is typically found to be fractured to depths of approximately 30 ft below the overburden contact, with some locations showing fractured bedrock depths of approximately 130 ft deep below the overburden contact. Localized faults are also present. Volcaniclastic, fragmental bedrock was found in the east near Kaskanak Mountain and in the southern section of the site.

The groundwater conditions observed at Site G include artesian flows and groundwater levels generally near surface, but sometimes up to 45 ft below surface.

#### *Open Pit Area*

Overburden in the open pit area ranges in thickness from 10 to 250 ft and generally consists of glaciofluvial, glaciolacustrine and glacial drift deposits. Available information on overburden is limited in this area; further site investigation is required to better characterize the overburden material. This is particularly important because the open pit pre-stripping materials are assumed to be available for construction of low-permeability zones in the tailings embankment.

Bedrock geology in the open pit area consists of Tertiary sediments, volcanics, volcanic-derived sediments, and Cretaceous intrusives (granodiorite and megabreccia), diorite, and extrusives.

The depth to groundwater varies throughout the open pit area, ranging from surface to approximately 50 ft.

#### CLIMATE AND HYDROLOGY

Climate and hydrology data are summarized as follows:<sup>1</sup>

- The long-term average annual temperature for the mine site is estimated to be 30.2°F, with average monthly temperatures ranging from a high of 52.1°F in July to 12.7°F in December.
- On average, temperatures at the mine site are 3.4°F cooler than at Iliamna.
- Wind data indicate that the wind typically blows from the southeast and northwest with an average speed of between 8 and 15 knots.
- The maximum wind speed recorded during the measurement period is 120 knots.
- Maximum solar radiation is expected in June, while minimum radiation is expected in December, based on data from King Salmon, Alaska, approximately 100 miles south-southwest of the Pebble site.
- Mean annual lake evaporation is estimated to be 7 inches.
- Mean annual sublimation for the mine site area is estimated to be 4 inches.

- Precipitation for the mine site area is estimated to be 36.6 inches.
- The rainfall design storm events are:
  - 24 hour probable maximum precipitation – 18 inches
  - 24 hour, 1 in 100 year precipitation at 1,000 ft elevation – 6.5 inches
  - 24 hour, 1 in 100 year precipitation at 1,550 ft elevation – 8.5 inches.
- Approximately 30% of precipitation at the mine site falls as snow. However, high wind speeds and low vegetation cover result in significant additional wind-blown snow accumulation at the site. Snow distribution surveys confirm that the mine site catchment is a snow accumulation area. A wind-blown contribution of an additional 8 inches of snow water equivalent (SWE) has been estimated for the mine site catchment.
- Mine site runoff results from rainfall and snowmelt, producing an annual hydrograph with two high flow seasons. The first peak occurs in April and May as a result of snowmelt, while the second peak occurs in August and September as a result of rainfall.

## SEISMICITY

Appropriate seismic design parameters for the TSF have been selected using the results of probabilistic and deterministic seismic hazard analyses, together with the hazard classification defined for the facilities. The preliminary hazard classification for the TSF has been assessed at Class II, based on the Guidelines for Cooperation with the Alaska Dam Safety Program. Seismic studies have been undertaken in three distinct areas as described in the following paragraphs.

First, existing public domain literature and information concerning the seismicity of the region has been compiled. Three key publications are referenced. Haeussler and Saltus (2004) studied aeromagnetic data associated with the seismic source zone closest to the Pebble Project, the Lake Clark Fault, and reported that its western end terminates some 10 miles from the Pebble property. Haeussler and Saltus also reported that the Lake Clark Fault could extend further to the southwest (closer to Pebble), but that lack of bedrock exposures limits field corroboration of the geophysical data. Willis et al. (2007) reported that an earthquake with a potential magnitude 6.9 to 7.3 could occur on the Lake Clark Fault. Wesson et al. (2007) utilized this information to assign a magnitude value of 7.1 to a Lake Clark Fault earthquake in the US Geological Survey's (USGS) revision of its Alaska seismic hazard model.

Second, site-specific data related to the Lake Clark Fault has been collected. In 2009, an airborne electro-magnetic geophysical survey was undertaken over the Pebble property and surrounding region. This type of survey allows for the identification of faults due to their unique response characteristics. This geophysical survey demonstrated that the Lake Clark Fault becomes splayed.

Third, a detailed survey of the surficial geology and geomorphology of the Pebble Project area has been conducted and reported by Hamilton and Klieforth (2009). This work assesses how glaciation has affected the surficial geology of the area, and thus the potential for groundwater flow. However, two important findings from this work influenced the Pebble Project seismicity study.

In the first of these findings, Hamilton and Klieforth traced the advance of four glacier phases in the region. These glaciers were preferentially advanced via crustal troughs formed by fault traces, such

that the mapped advances corroborate the geographically indicated splayed extension of the Lake Clark Fault. The second finding, based on discussions with Hamilton, no evidence was found of movement along these faults in the surficial deposits. This would indicate that the Lake Clark Fault has been inactive over the approximately 10,000-year period since glaciers last receded from the region.

Based on this data, seismic design criteria for the TSF and other mine-site facilities has been developed using both probabilistic and deterministic methodologies. The probabilistic method utilizes seismic data from the region to determine the likelihood of occurrence of earthquakes of certain magnitudes in the project area. The deterministic analysis assesses the maximum forces on the TSF embankments from potential seismic epicentres, based on estimates of energy release, distance from the epicentre and attenuation effects.

Two seismic source zones have been identified that could affect the Pebble Project:

1. the Lake Clark Fault; and,
2. the large Pacific Plate–North American Plate subduction zone located offshore, east of the Alaskan Peninsula.

Potential energy release from the offshore subduction zone is considerably greater than that of the Lake Clark Fault. A magnitude 9.2 mega-thrust earthquake, equal to the 1964 Alaskan earthquake that originated from this zone, is considered to be the maximum credible event (MCE). However, the distance of this seismic source zone from the Pebble property, and the effects of energy attenuation, would result in considerably lower ground acceleration at Pebble than a smaller earthquake along the Lake Clark Fault.

Although the Lake Clark Fault is considered to have been inactive for some 10,000 years, and the USGS's Alaska seismic hazard model assigns a magnitude value of 7.1 to a Lake Clark Fault earthquake, seismic design criteria for the Pebble Project TSF are considerably more conservative.

Seismic design criteria for the Site G TSF and other mine-site facilities are based on a deterministic analysis utilizing available data for minimum distances from the Lake Clark Fault to the three Site G tailings embankments. A magnitude 7.5 earthquake has been utilized as the maximum credible event (MCE), in excess of the magnitude 6.9 to 7.3 potential documented in recent literature. Attenuation models utilized have been published as recently as 2008.

The results of this deterministic analysis indicate that the maximum credible ground acceleration on rock at the Site G TSF north embankment is 0.44 g, while the maximum credible ground acceleration on rock at the south embankment is 0.47 g. These earthquake parameters have been used to assess the stability of the TSF under seismic loading. To account for the potential amplification of ground motion as seismic waves propagate through the foundation soils and embankments, an amplification factor of 1.5 has been used to model the average maximum ground acceleration along a potential slip surface through the embankment.

The Pebble Partnership has made very conservative assumptions in determining these seismic risks for the designs of the Pebble TSF and other mine facilities.



### 18.3.3 TAILINGS AND WASTE ROCK CHARACTERISTICS

#### TAILINGS AND TAILINGS WATER CHARACTERISTICS

The tailings physical characteristics are based on testwork completed in 2008. Tailings particle size distributions indicate that the bulk tailings are uniformly graded, consisting of sand and silt-sized particles, with a  $P_{80}$  of 200  $\mu\text{m}$ . Preliminary particle size distributions on the cleaner scavenger tailings indicate that these consist of predominantly silt-sized particles, with a  $P_{80}$  of 30  $\mu\text{m}$ .

The permeability of tailings deposits tends to decrease over time as the deeper tailings consolidate due to progressive loading. The filling schedule for the TSF is based on an estimated average dry density of 85 lb/ft<sup>3</sup> for the bulk tailings and 110 lb/ft<sup>3</sup> for cleaner scavenger tailings, which have a higher specific gravity.

Static geochemical testing indicates that the bulk rougher flotation tailings can be produced with low sulphur concentrations of between 0.1% and 0.2% sulphur as sulphide, and sufficient carbonate content to offset acid generating potential. No geochemical testing has been completed on the cleaner scavenger tailings. However, the pyrite content of these tailings indicates that they may have potential to create acidic conditions if permitted to oxidize.

Preliminary modelling of the tailings water quality is in progress and will be updated for the next design stage.

#### WASTE ROCK CHARACTERISTICS

To determine waste rock characteristics, more than 1,000 samples from diamond drill core, 785 samples from Cretaceous rocks and 234 samples from Tertiary units, were obtained during drill programs conducted between 1988 and 2007 and analyzed. The samples have been selected to provide broad lithological and spatial coverage and a range of core ages. Ten additional samples were obtained from surficial deposits of glacial sediments and overburden.

Sulphur and calcium results from the analyses show that these elements are the best surrogates for determining acid potential (AP) and neutralizing potential (NP). Based on results from kinetic tests, any rock with an NP/AP ratio greater than 1.6 or 1.8 for pre-Tertiary and Tertiary rock, respectively, is predicted to be not potentially acid generating (NAG). In this Preliminary Assessment, the NP/AP ratio to segregate PAG and NAG during mining of the Pebble deposit is 1.6 to 1.<sup>2</sup>

Acid-base accounting testing showed that the Tertiary rocks are dominantly NAG, due to the presence of low sulphur concentrations and elevated carbonate content as calcite. In fact, no samples of Tertiary rock generated acidic conditions under field or laboratory conditions.

### 18.3.4 TAILINGS IMPOUNDMENT DESIGN AND CONSTRUCTION

The Site G TSF will be approximately 3 miles long and approximately 685 ft deep. The TSF impoundment is sized to provide additional freeboard for complete containment of all runoff from the inflow design flood, for wave run-up protection, and for any post-seismic embankment settlement. The probable maximum flood (PMF) has been selected as the inflow design flood and Maximum Credible Earthquake was selected as the design seismic event.

The zoned embankments will be constructed in stages throughout the life of the project using selected overburden and NAG Tertiary waste rock derived from open pit stripping operations.

Drilling results and outcrop distributions indicate that overburden is thin over much of the area and that bedrock is often fractured through the top 50 ft of bedrock. Response testing indicates that some overburden materials and the upper bedrock have a hydraulic conductivity ranging from  $10^{-4}$  to  $10^{-3}$  cm/sec. Hydraulic conductivity generally decreases with depth and is in the order of  $10^{-5}$  to  $10^{-7}$  cm/sec in bedrock. However, some zones of higher hydraulic conductivity were also observed at depth.

The TSF design basis includes the following information:

- Operating Life ..... 25 years
- Nominal ore production (after ramp-up period)..... 200,000 tons per day
- Portion of ore to bulk tailings ..... 85%
- Portion of ore to pyritic tailings..... 14%
- Width of north embankment base ..... 2,600 ft.

The Site G TSF will ultimately have three embankments. The north embankment will be constructed at mine start up (200 ft high). The south and east embankments will be required as the material stored in the impoundment reaches its capacity, at which point the north embankment will be 685 ft high.

#### FOUNDATION PREPARATION AND FOUNDATION SEEPAGE CONTROL MEASURES

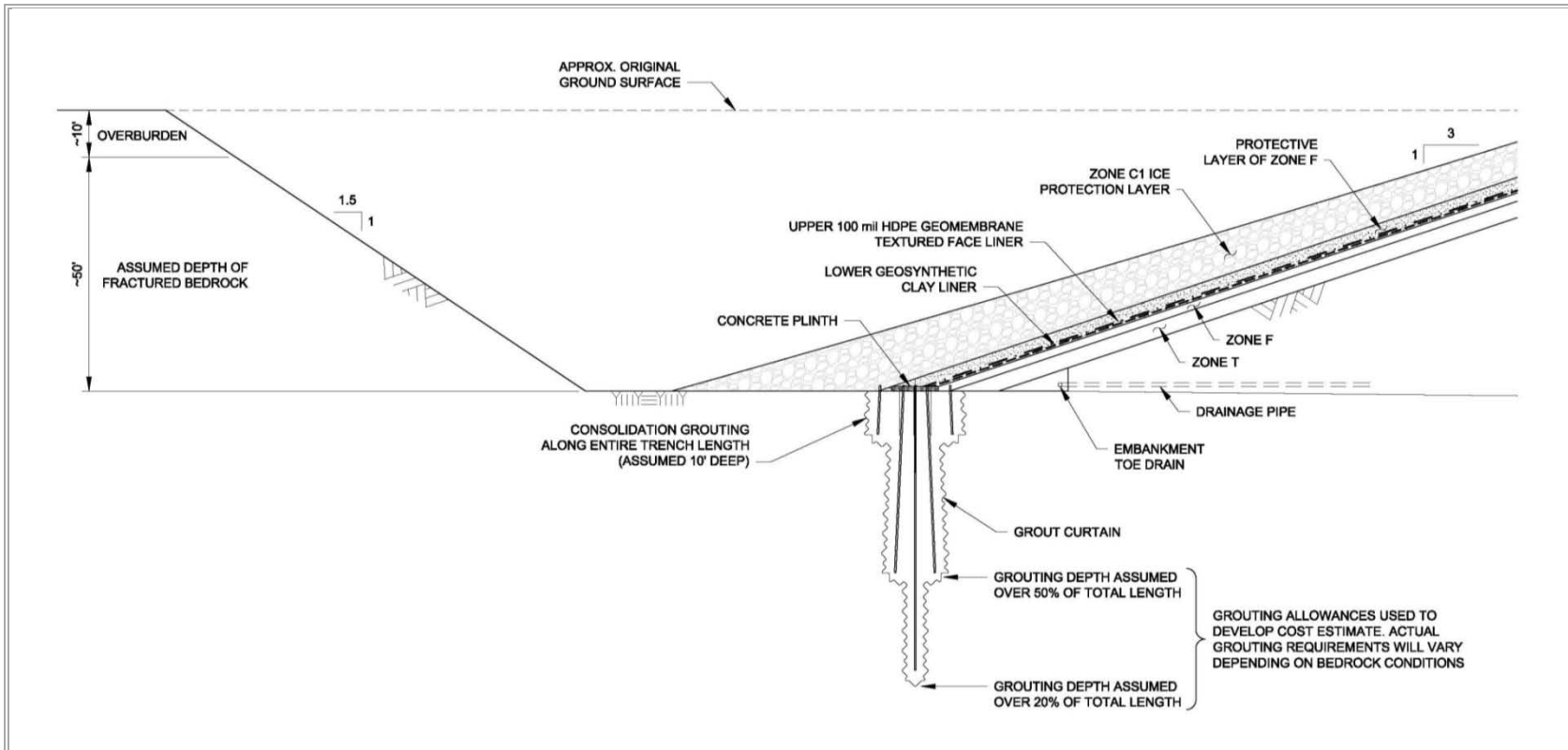
Embankment foundations will be prepared by removing all organics and unsuitable materials prior to controlled rockfill placement on competent overburden and/or bedrock foundations. The organic materials will be stockpiled for reclaiming the embankments at closure.

The implementation of effective seepage control and collection measures is a fundamental requirement for the design and operation of the TSF to address impacts on groundwater and surface water interconnections and meet regulatory compliance. A schematic of the seepage control measures is shown in Figure 18.3.1.

The seepage control system construction consists of the following key elements:

- A seepage cutoff trench will be excavated along the upstream toe of each of the embankments. Suitable material from the trench excavation will potentially be used as embankment fill material.
- The bedrock surface at the base of this excavation will be cleaned and treated by slush grouting and dental concrete placement in any cracks or fissures prior to the construction of a concrete plinth and filter/transition materials.

Figure 18.3.1 Schematic of Seepage Control Measures with the Grout Curtain Trench



- Consolidation and curtain grouting will be performed through pipe sleeves embedded along the concrete plinth to ensure a good seal at the plinth-bedrock contact. Consolidation drilling/grouting will be carried out in a systematic pattern extending to an approximate depth of 10 ft to grout surficial features resulting from the blasting operations for the trench excavation.
- A geomembrane face liner will be connected to the plinth and extended up the embankment face. A seepage collection system will be constructed within the trench excavation immediately downstream of the upstream liner and associated fill zones. This upstream toe drain will extend along the extent of the excavations and will drain into secondary drainage trenches that will be excavated perpendicular to the embankment axis. These drainage trenches permit gravity drainage of any seepage collected in the upstream to drain to the seepage recycle ponds.

#### EMBANKMENT DESIGN SECTION AND STAGED CONSTRUCTION

The ultimate plan view arrangement for the Site G TSF is shown in Figure 18.3.2. The design section for TSF zoned embankments is presented in Figure 18.3.3 and briefly described below:

- The overall downstream slope of the embankment is 2H:1V. The upstream slope within the initial embankment will be constructed at a 3H:1V. The centreline construction will involve installation of a vertical low permeability core zone.
- The shell zone is to be constructed from material excavated from the upstream toe trench and local quarry during the initial construction of the TSF, and from well-graded NAG Tertiary waste rock obtained from the open pit during operations.
- The low-permeability core zone is to be constructed from well-graded, low-permeability, silty glacial till.
- The transition zone will comprise at least two zones, a sand filter (Zone F) immediately down-gradient of the core zone and a second gravelly transition zone (Zone T) between the Zone F filter and down-gradient of the shell materials. The transition zone extends to the base of the upstream toe trench and provides a bedding layer for the composite liner.
- The Zone U will form the upstream shell zone immediately adjacent to the core zone and will be constructed from well-graded NAG Tertiary waste rock.
- A 100 mil thick high-density polyethylene (HDPE) textured geomembrane liner will be placed on the upstream face of the lower section of the embankments. The HDPE liner will be placed on a geosynthetic clay liner (GCL) for seepage control during initial filling and the early years of operation of the tailings impoundment. The liner will be extrusion-welded onto an embedded HDPE strip in the concrete plinth in the seepage cut-off trench along the upstream toe of the embankment.

Figure 18.3.2 Final Site Arrangement – 25-Year IDC Case

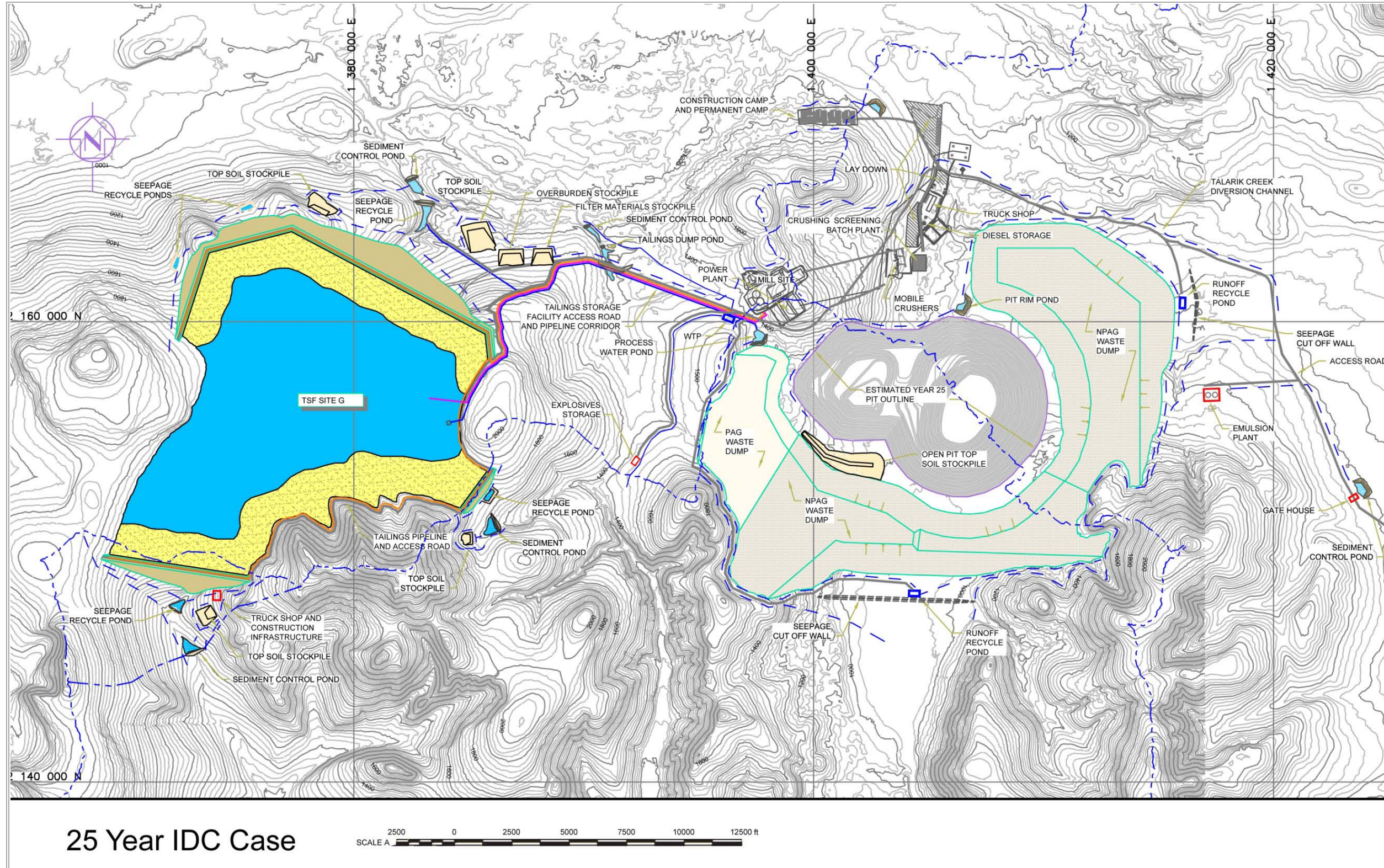
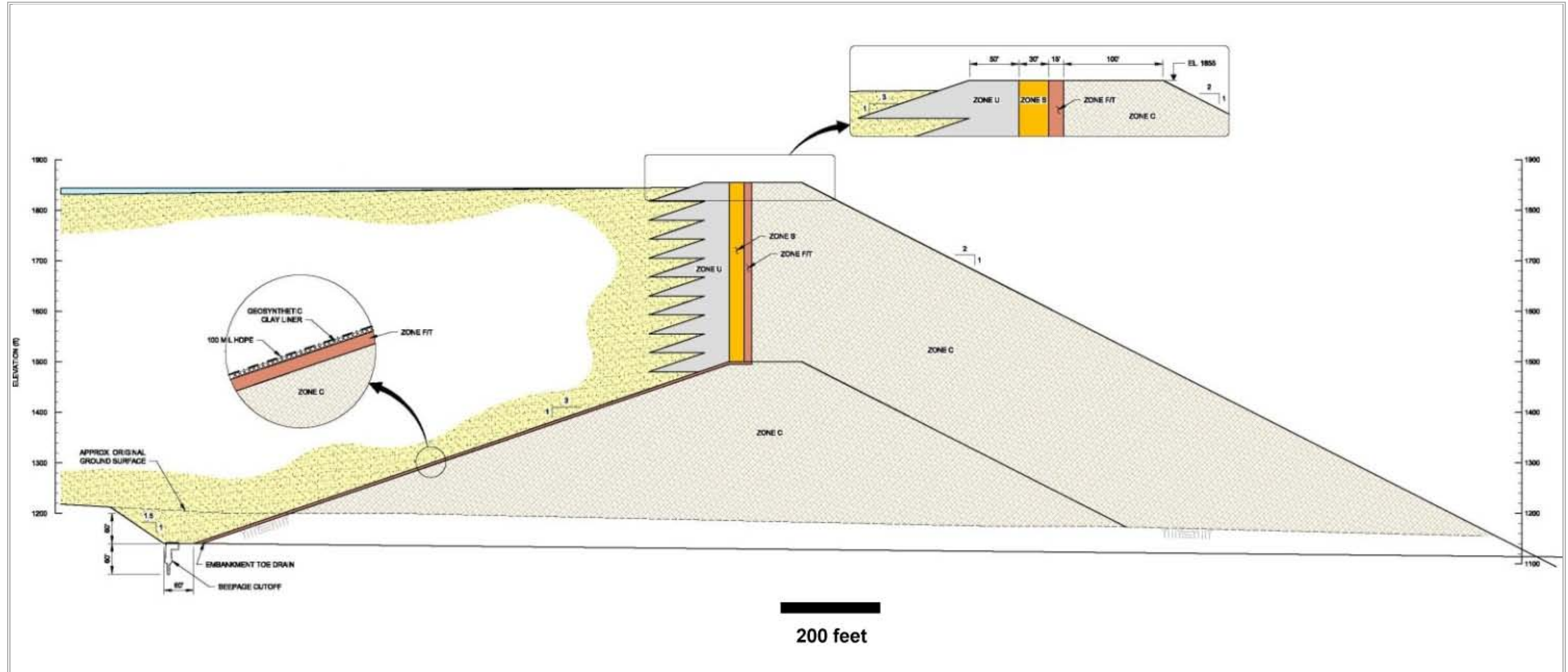


Figure 18.3.3 Typical North Embankment Section



- The liner cover will be constructed on the upstream face liner for GCL confinement and to protect the GCL/HDPE liner composite from ice damage when the water pond is in direct contact with the liner during winter months. The liner cover is only required during the initial pond filling period because the tailings beaches will provide protection once they have been developed. The cover will include a sandy protective layer in direct contact with the liner, followed by a coarser, potentially processed rockfill material for erosion protection.

Construction staging can be summarized as follows:

- The initial starter embankment will be approximately 200 ft high. Construction of the stage 1 embankment will start in Year -2 and will be completed in the third quarter of Year -1 to allow for the collection and storage of water in the TSF during the first 8 months of mine operation in order to supply the mill with process water at start-up.
- Subsequent, staged expansion of the embankments will result in an ultimate embankment height of 685 ft for the north embankment, 400 ft for the south embankment, and 100 ft for the east embankment.
- The tailings embankments will be progressively expanded using downstream construction methods for the initial years, switching to centerline construction. This switch requires the development of competent tailings beaches. The east embankment, which is approximately 100 ft high, will be constructed using downstream construction methods only.

### Site Monitoring

Instrumentation for monitoring performance of the embankments will be installed and monitored during the construction and operation of the facilities. The instrumentation will include piezometers, surface survey monuments, settlement plates, and slope inclinometers. Groundwater monitoring and recovery wells will also be installed downstream of all embankments to provide ongoing groundwater quality data.

### EMBANKMENT STABILITY

The assessment of TSF embankment stability has three components:

1. assessment of site specific factors, such as Pebble Project site seismicity, geotechnical profile and local construction materials;
2. incorporation of these factors, or more stringent regulatory requirements if they exist, into the embankment design; and
3. evaluation of the stability of the resulting embankment design.

This was an iterative process, with new data collected continually and the design subsequently updated based on re-evaluation. TSF embankment stability assessment will continue through the life of the mine. As embankments are raised each year, performance will be monitored and the design adjusted, if required.

The results of the stability analyses for the Site G TSF indicate that the predicted maximum embankment displacements and potential crest settlement under seismic loading from a magnitude 7.5 earthquake associated with possible extensions of the inactive Lake Clark fault are minor and would

not significantly affect embankment freeboard or result in loss of embankment integrity. The performance and integrity of the embankment core, drainage and filter zones would be unaffected by the predicted deformations. As the Lake Clark Fault has been documented to be inactive for some 10,000 years, the Site G TSF embankments, in essence, have been conservatively designed.

**18.3.5 TAILINGS PIPEWORKS**

**BULK TAILINGS DELIVERY SYSTEM**

Bulk tailings are thickened at the process plant using one 400 ft diameter thickener. The thickened tailings are pumped to the TSF in two 34-inch steel pipelines. A booster pump will be required in year 3. The bulk tailings pipelines will run along the crest of the embankment. An internal lining will protect the steel pipe from corrosion and abrasion. All of the valves used in the tailings system will be heavy-duty hydraulically actuated knife gate valves, suitable for use in slurry applications. Full bore valves will be used to reduce wear.

Tailings discharge points will be located at 1,600 ft intervals along the TSF perimeter for the controlled development of tailings beaches and to allow operating flexibility as necessary to mitigate against wind erosion and dusting from the tailings beaches. Because of their size, the valves will be actuated with hydraulic cylinders.

**CLEANER SCAVENGER TAILINGS DELIVERY SYSTEM**

The cleaner scavenger tailings lines consist of two 18 inch steel pipes. An internal lining will protect the steel pipe from corrosion and abrasion. The maximum duty requires six slurry pumps in series for each train, although only three pumps will be installed in each train initially. The cleaner scavenger tailings are deposited subaqueously into the supernatant pond.

**RECLAIM WATER SYSTEM**

The reclaim water system includes a pumping and pipeworks system that extends from the reclaim water barge to the mill site process water tank. Reclaim water will be pumped to a head tank on the east side of the TSF, which in turn will feed a pipeline through which the water will flow by gravity to the process water pond. Each barge requires three operating pumps. Axial flow pumps are used. The combined design flow for the three pumps is 45,000 gpm. The reclaim water system has a single 42 inch pipe (HDPE from the barge to the head tank and steel from the head tank to the process water pond).

**18.3.6 WASTE ROCK MANAGEMENT**

Design basis for the waste management of the 25 year IDC Case can be summarized as follows:

- PAG waste rock ..... 634 million tons
  - total PAG considers 5% of all NAG to be PAG
  - in-place dry density is 130 pcf
- NAG waste rock ..... 2.379 billion tons
  - in-place (embankments) density is 144 pcf
  - in-place (NAG Waste Rock Dump) is 130 pcf.



The NAG waste rock will be stored in waste dumps south and east of the mine workings and the expansion of the waste dumps will be staged to reduce the runoff, which would require treatment. Because of its low potential for acid generation, the NAG waste rock is suitable for construction of tailings embankments and other permanent facilities requiring rockfill.

The PAG waste dump will be on the western side of the pit. PAG waste rock contains low-grade copper mineralization that will be processed at closure, with the tailings being discharged into the open pit.

Monitoring and recovery wells, as well as seepage cut-off walls, extending into low-permeability zones, will be constructed downstream of the waste dumps for seepage management/control. Zoned embankments will be constructed above the seepage cut-off walls to provide containment of waste dump surface runoff flows from any storm events that exceed the capacity of the runoff collection ponds, and the pumping and pipeworks systems. Runoff from waste dumps will be pumped to the process water pond (Figure 18.3.5).

### 18.3.7 CLOSURE CONSIDERATIONS

The TSF will be monitored in order to maintain long-term physical and geochemical stability. Protection of the downstream environment will be comprehensively addressed in the closure plan, including re-vegetation of embankment faces and exposed tailings surfaces, incorporating wetlands and ponds on the reclaimed tailings surface, and construction of a runoff overflow system.

Waste rock dumps will be constructed in order to minimize practical closure liability, including siting within the pit groundwater cone of depression and ensuring conduciveness for re-vegetation and water management. PAG waste rock will be processed in the mill for metal recovery at the end of operations with resulting tailings to be discharged into the open pit. Once the PAG waste rock has been removed, the base will either be removed for in-pit disposal or covered with soil and re-vegetated. NAG waste rock that remains at the rim of the open pit will be covered with soil and re-vegetated.

### 18.3.8 CAPITAL AND OPERATING COST ESTIMATE FOR TSF AND RELATED INFRASTRUCTURE

The capital cost of the TSF and related infrastructure is estimated at US\$249.9 million, as shown in Table 18.3.1.

**Table 18.3.1 Capital Cost for TSF and Associated Infrastructure**

Tailings Capital Cost (US\$ M)	
Tailings Storage Facility	132.0*
Tailings Pipeline	96.4
Reclaim System	21.5
<b>Total</b>	<b>249.9</b>

Note: \*estimate assumes transporting and stockpiling a crushed run of mine material via conveyor to the tailings dam site and utilizing a stacking conveyor system to spread the material for compaction.

### 18.3.9 SUMMARY

Locations of suitable sites and ground preparation necessary for tailings and waste storage for the 25-year IDC Case have been comprehensively investigated. Significant analytical effort has been expended on understanding the tailings and waste rock characteristics. The results of these analyses

have been incorporated into the engineering design of the embankments and tailings delivery systems. These designs may be subject to refinements as new information becomes available (e.g. tailings water chemistry) in subsequent design stages.

Other tailings storage facilities, with similar design concepts are being considered to accommodate additional material requirements for the 45-year Reference Case and the 78-year Resource Case. While the location of these facilities is as yet unconfirmed, topographical/land status and seismic conditions in the project area present a number of site options subject to further design effort within the environmental risk mitigation framework.

### 18.3.10 MINE SITE WATER MANAGEMENT

#### GENERAL

The main objective of the water management plan is to control, in an environmentally responsible manner, all water that originates within, or is brought into, the project area. The water management plan has been developed based on the layout of the project facilities, process requirements, topography of the project area, and hydrometeorology. Water flow rates will vary with changes to the mine plan, milling rates, site disturbances, hydrometeorology and runoff coefficients. Therefore the water management components and overall water management strategy will be continually revisited during subsequent design stages.

#### WATER MANAGEMENT PLAN

The following is a summary of the water management plan during pre-production, operations, and closure.

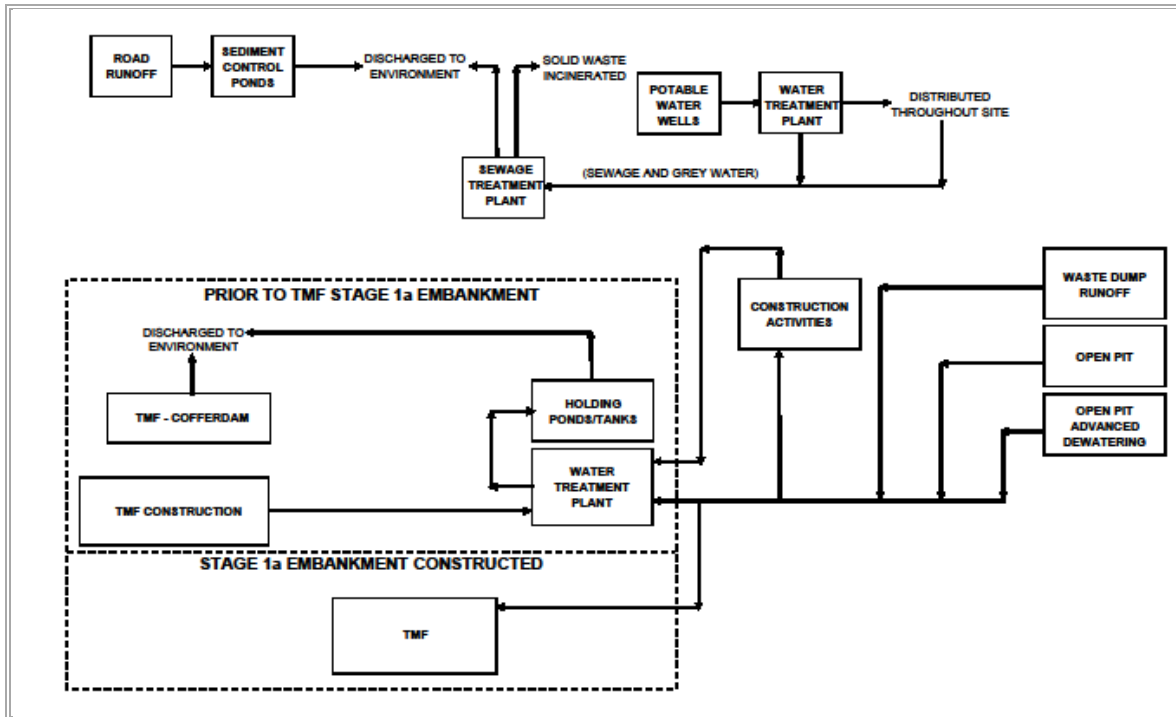
##### *Pre-production*

During the pre-production phase, the water management plan consists of establishing site-wide diversion and sediment control measures, including diversion channels, runoff collection ditches and sediment control ponds. A coffer dam will be constructed upstream of the TSF to manage water during seepage cut-off and transverse trench excavation, grout curtain installation, embankment foundation preparation and Phase 1 embankment construction. All water collected behind the coffer dam will be tested to determine if discharge requirements are met prior to pumping to a location downstream of all construction activities.

Advanced dewatering of the deposit area will commence during pre-production and will continue into operations. Minimal water storage will be available until the completion of the TSF Stage 1a embankment so prior to this, all site water will be treated, if required, and released as it is collected, with the process water pond providing surge capacity. Once the Stage 1a TSF embankment is completed, a sufficient volume of water will be collected behind it for mill start-up and operations.

A flowsheet of the site-wide water management plan during pre-production is shown in Figure 18.3.4.

Figure 18.3.4 Pre-Production Site-Wide Water Management Plan



### Operations

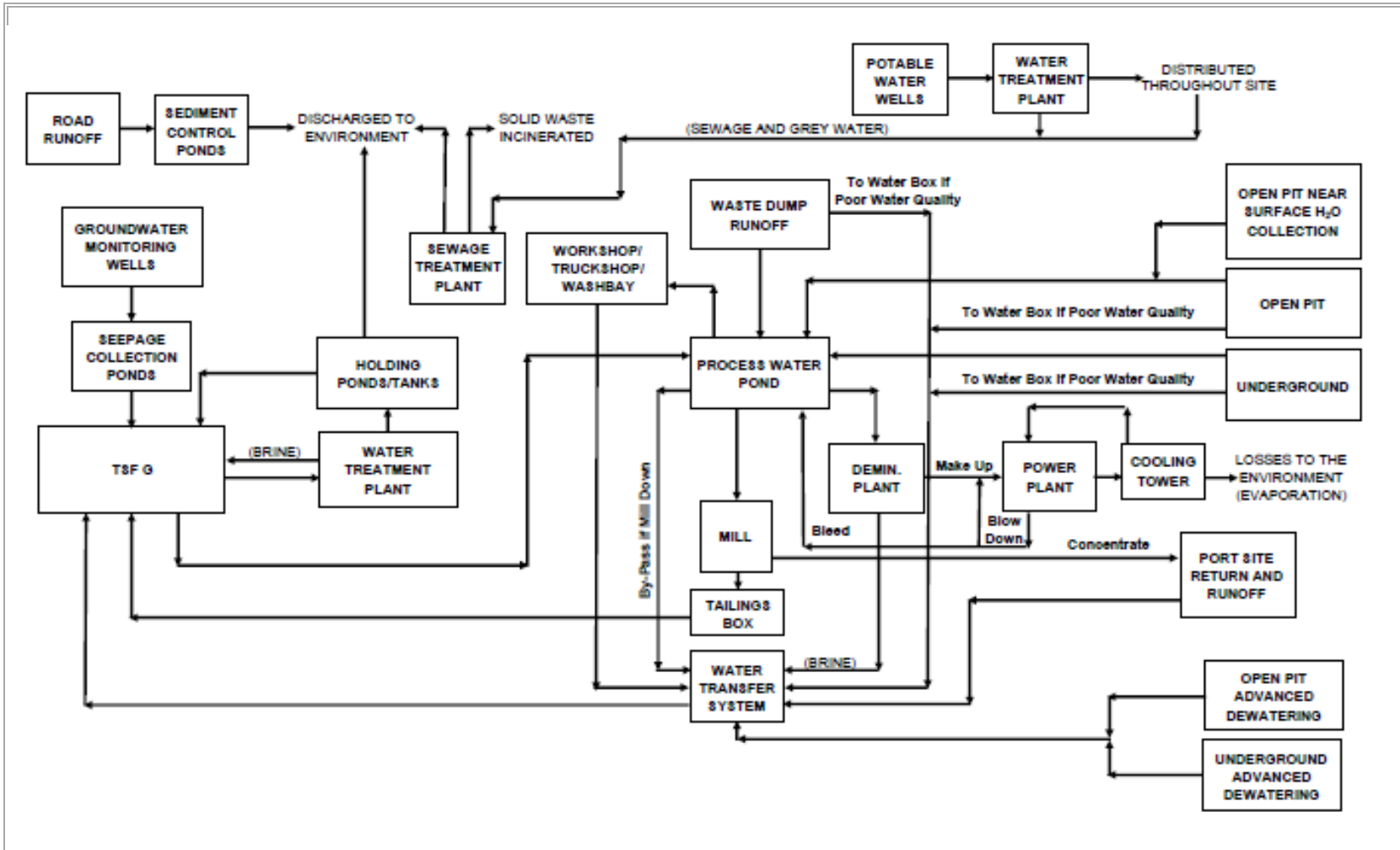
During mine operations, the water management and sediment control plan will maintain the site-wide diversion and sediment control measures established during pre-production. Water from the mine site, open pit groundwater and surface runoff, mine site runoff and waste dump runoff will, dependent upon quality, will be used to supply the process water pond. Water not meeting quality standards will be routed to the TSF. Clean water for mill operations (gland water) will be provided by treating reclaim water from the TSF at an onsite treatment plant.

Water will be recovered from concentrate slurry at the port site, combined with any port site runoff, and pumped to the mine site where it will be routed to the TSF via the water transfer pipeline.

A flowsheet of the site-wide water management plan during operations is shown in Figure 18.3.5.

Any seepage from the TSF and runoff from the TSF embankments will be collected in seepage recycle ponds. Seepage and embankment runoff will either be pumped back to the TSF or plumbed into the reclaim line.

Figure 18.3.5 Operations Site-Wide Water Management Plan



1056140100-REP-R0001-00

*Open Pit Dewatering*

The open pit dewatering system has been sized to remove inflows from direct precipitation and groundwater inflow to the open pit. Direct precipitation consists of rainfall incident on the open pit footprint and snow accumulation/melt based on accumulated meteorological data, and using a 33% snow-water equivalent.

There will be two open pit dewatering systems, one for the east side of the pit and one for the west side. Each system will consist of fixed low-flow pumps and barge pumps installed in open sump ponds or rock-filled sumps. The sumps will be used to minimize any problems with icing during winter operations. Each system will feed booster pump stations, which will pump water to a final surface booster pump station. The water will then be pumped up to the process water pond, providing it meets specified water quality standards. Otherwise, the water will be routed to the TSF via a water transfer pipeline.

A collection bench will be integrated into the open pit design and development to intercept shallow groundwater flowing into the pit before it reaches the pit bottom. This collection bench is assumed to be located at elevation 750 ft. This water will be pumped out of the pit to the surface booster pump station by barge pumps.

Open pit sumps have been sized for 24 hours of inflow during an average spring snowmelt month (May). Pumps and pipes have been sized for the 1-in-10-year, 24-hour storm event occurring during an average May, with removal of the storm event occurring over a 14-day period.

Pumping rates for the open pit dewatering system are provided in Table 18.3.2 and Table 18.3.3.

**Table 18.3.2 Upper Bench Open Pit Dewatering– Annual Average Pumping Requirements**

Mine Year	Upper Pit Bench Open Pit Dewatering (USgpm)	
	West	East
5	750	3,300
25	940	4,000

**Table 18.3.3 Pit Bottom Open Pit Dewatering – Annual Average and Peak Pumping Requirements**

Mine Year	Open Pit Annual Average Pumping Rates (USgpm)		Open Pit Bottom Peak Pumping Rates (USgpm)	
	West	East	West	East
5	540	820	6,400	7,700
25	900	2,300	9,700	22,600

### Closure

With exhaustion of the open pit resource, stockpiled PAG rock will be processed through the process plant and the tailings deposited in the open pit following completion of mining. Water required for the process will be obtained from surface runoff from the waste dumps, TSF and mine site area. Additional make-up water will be reclaimed from the pit. All site surplus water will be routed to the pit until such time that the water reaches the specified maximum post-closure water level that still maintains groundwater inflow conditions. Thereafter, the water will be pumped to a water treatment plant for treatment and discharge until such time as the water can be released without treatment.

### WATER BALANCE

#### Assumptions and Input Parameters

The key assumptions and input parameters used in the water balance are listed below:

- Minimal water storage is available on site until the Stage 1 TSF has been constructed from material excavated; all site water collected prior to this will be treated, if required, and discharged to the environment.
- Start-up water supply for the process is sourced from the TSF.
- Runoff from the undisturbed areas will be treated for sediment and discharged to the environment.
- All precipitation from April to October is assumed to be rain. All precipitation from November to March is assumed to be snow, with 15% of the snow melting in April, 80% in May, and 5% in June.
- An additional 8 inches of snow-water equivalent is assumed to accumulate in the open pit.
- 90% of the water in the concentrate slurry is assumed to be recovered and returned to the TSF with port site runoff.

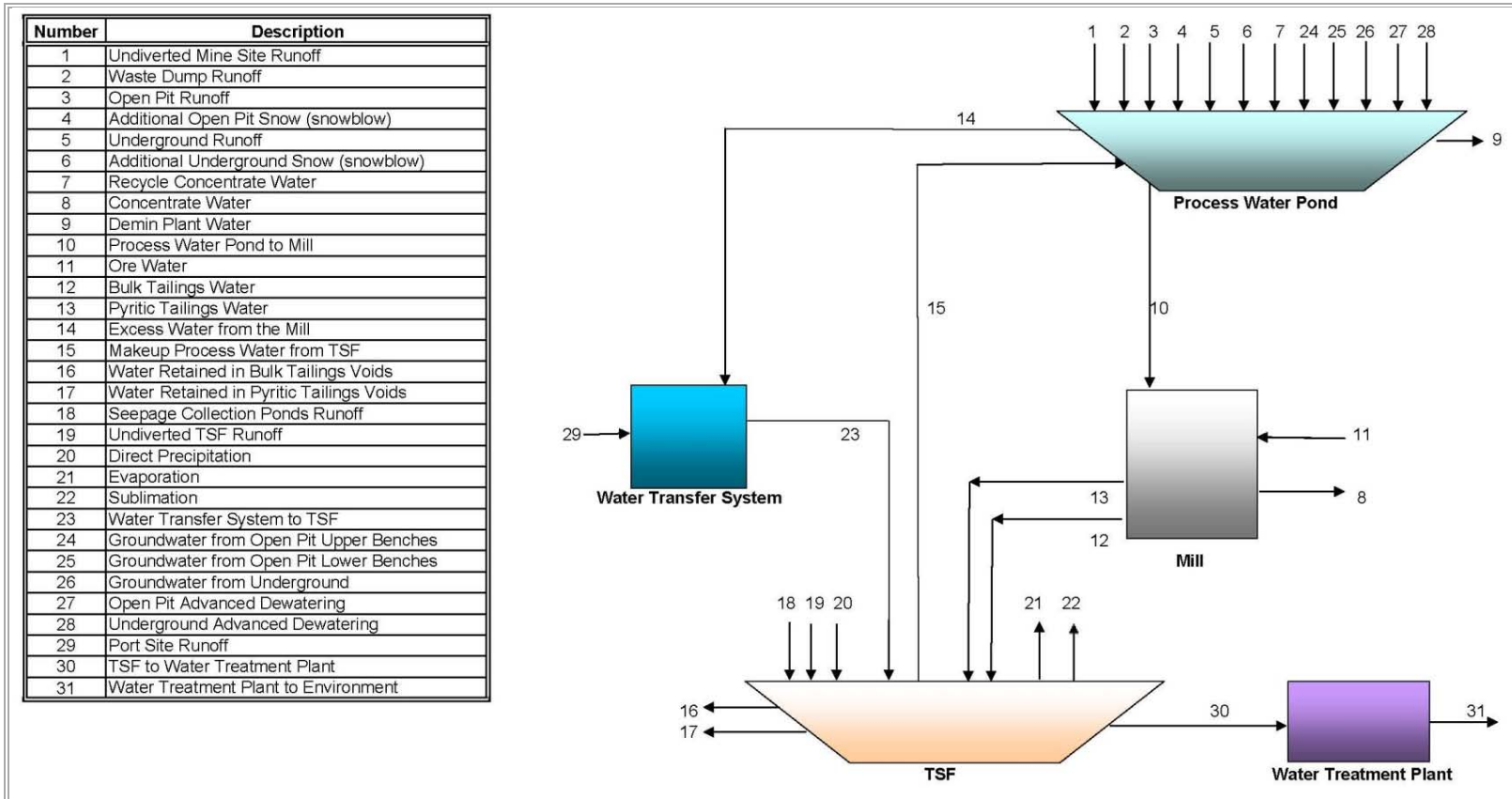
Average annual precipitation values, in rainfall equivalents, used for various project areas are as follows:

- TSF (elev. 1,450 ft).....41.7 inches per year
- Mine site (elev. 1,300 ft).....39 inches per year
- Waste dumps (elev. 1,550 ft) .....41.3 inches per year
- Open pit and underground (elev. 1,050 ft)..... 36.9 inches year
- Port Site 1..... 72 inches per year

#### Water Balance Results

The results of the water balance indicate that there is a site-wide water surplus during the entire mine life. A schematic of the water balance is provided in Figure 18.3.6.

**Figure 18.3.6 Water Balance Flows**



## WATER TREATMENT

### *Introduction*

The water treatment process will utilize a combination of chemical addition, clarification, and filtration to meet the most stringent water quality standards under EPA and State of Alaska regulations. Beyond mine year 5, sulphate and total dissolved solids will be removed using reverse osmosis (RO) to meet regulated water quality standards. The processes selected are well understood, sufficiently robust, and are widely used in industrial water treatment settings.

The water treatment plant (WTP) is sized to treat 135% of the average annual surplus flow during both pre-production and operations. ‘Surplus flows’ are defined as the water that cannot be stored in the current tailings facility design and therefore must be treated and discharged. The plant will expand over the mine life to provide for additional hydraulic capacity and process capabilities when the volume of treated water increases.

### *Water Chemistry*

Influent water chemistry is based on a deterministic monthly mass load balance. Complete mixing of water is assumed. The foundation of this model was the previously described water balance analysis.

The WTP design limits will meet the most stringent water quality standards under EPA and State of Alaska regulations (Table 18.3.4).

### *Flow Rates*

The projected WTP influent flow rates are based on the water balance model. The WTP will have the capacity to meet or exceed these projected inflow rates by increasing its capacity over time by using modular process equipment that is installed at periodic intervals over the mine life. The process equipment is sized based on the project flow requirement for the current year, but consideration is also given to the flow requirement in the following years to maximize process and cost efficiencies.

### *Process Design*

The constituents that influence the water treatment process design are metals and metalloids (primarily manganese, selenium, and aluminum), total dissolved solids (TDS), and sulphate. Treatment for these constituents becomes necessary over time in the order stated. Consequently, the selected treatment process only requires metal/metalloid removal using chemical addition, clarification and filtration during the pre-production years. Once treatment is required for TDS and sulphate, a side-stream membrane system will be added to reduce the concentration of these constituents to approved levels. Prior to Year 25, pH is estimated to be near neutral. At Year 25, geochemical effects are anticipated to change the water chemistry in the TSF such that the WTP influent will require pH adjustment. This assumption will be verified in future studies.



**Table 18.3.4 Industrial Wastewater Discharge Permit Limitations for Freshwater Discharge**

Parameter	Units	Chronic Aquatic Life Criteria (CALC)	Drinking Water Standard	Most Stringent AWQS
Hardness	mg/L	NA	NA	
pH	pH Units	>6.5 & <8.5, not >0.5 from natural	>6.0 and <8.5	>6.5 and <8.5
Fecal Coliform	#/100 ml		20	
Temperature	°C	<13 C	<15 C	<13
Colour		50	15 units	
DO	mg/L	>7 & <17, and >5 in spawning gravel	>4	>4, <17
Turbidity	NTU	25> backgrd, lakes 5> backgrd	5> background	5> background
Conductivity	umhos/cm	NA	NA	NA
Total Dissolved Solids	mg/L	1000	500	500
Total Suspended Solids	mg/L	NA	NA	NA
Acidity	mg/L	NA	NA	NA
Alkalinity	mg/L	>=20	NA	>=20
Nitrate/ Nitrite	mg/L	NA	10	10
Phosphorus	mg/L	NA	NA	NA
Chloride	mg/L	230	250	230
Fluoride	mg/L	NA	4	NA
Sulphate	mg/L	NA	250	250
Total Cyanide	mg/L	NA	NA	NA
Cyanide WAD	mg/L	0.0052	0.2	0.0052
Thiocyanate	mg/L	NA	NA	NA
Ammonia	mg/L	0.179-6.67, 0.442-10.8	NA	0.179-6.67, 0.442-10.8
Aluminum <sup>(under revision)</sup>	Total	µg/L	87	87
	Dissolved	µg/L	87	87
Antimony	Total	µg/L	NA	6
	Dissolved	µg/L	NA	NA
Arsenic	Total	µg/L	150	10
	Dissolved	µg/L	150	NA
Barium	Total	µg/L	NA	2000
	Dissolved	µg/L	NA	NA
Beryllium	Total	µg/L	NA	4
	Dissolved	µg/L	NA	NA
Bismuth	Total	µg/L	NA	NA
	Dissolved	µg/L	NA	NA
Boron	Total	µg/L	NA	NA
	Dissolved	µg/L	NA	NA
Cadmium	Total	µg/L	0.10 - 0.76	5
	Dissolved	µg/L	0.88 - 0.69	NA
Calcium	Total	µg/L	NA	NA
	Dissolved	µg/L	NA	NA
Chromium	Total	µg/L	28 - 268	100
	Dissolved	µg/L	24 - 230	NA
Cobalt	Total	µg/L	NA	NA
	Dissolved	µg/L	NA	NA
Copper	Total	µg/L	2.9 - 30	NA
	Dissolved	µg/L	2.8 - 29	NA

Table continues...

...Table 18.3.4 (cont'd)

Parameter		Units	Chronic Aquatic Life Criteria (CALC)	Drinking Water Standard	Most Stringent AWQS
Iron	Total	µg/L	1000	NA	1000
	Dissolved	µg/L	1000	NA	1000
Lead	Total	µg/L	0.54 - 19	15	0.54 - 19
	Dissolved	µg/L	0.53 - 11	NA	0.53 - 11
Magnesium	Total	µg/L	NA	NA	NA
	Dissolved	µg/L	NA	NA	NA
Manganese	Total	µg/L	NA	50	50
	Dissolved	µg/L	NA	NA	NA
Mercury	Total	µg/L	0.012	2	0.012
Molybdenum	Total	µg/L	NA	NA	NA
	Dissolved	µg/L	NA	NA	NA
Nickel	Total	µg/L	16 - 169	100	16 - 169
	Dissolved	µg/L	16 - 168	NA	16 - 168
Potassium	Total	µg/L	NA	NA	NA
	Dissolved	µg/L	NA	NA	NA
Selenium	Total	µg/L	5.00	50	5.00
	Dissolved	µg/L	4.61	NA	4.61
Silicon	Dissolved	µg/L	NA	NA	NA
Silver	Total	µg/L	0.37 - 44	NA	0.37 - 44
	Dissolved	µg/L	0.31 - 37	NA	0.31 - 37
Sodium	Total	µg/L	NA	NA	NA
	Dissolved	µg/L	NA	NA	NA
Thallium	Total	µg/L	NA	2	2
	Dissolved	µg/L	NA	NA	NA
Tin	Total	µg/L	NA	NA	NA
	Dissolved	µg/L	NA	NA	NA
Vanadium	Total	µg/L	NA	NA	NA
	Dissolved	µg/L	NA	NA	NA
Zinc	Total	µg/L	37 - 387	NA	37 - 387
	Dissolved	µg/L	36 - 382	NA	36 - 382

Notes:

- (1) CALC come from the ADEC Alaska Water Quality Criteria Manual – Table III and from the ADEC Water Quality Standards for Fresh Water Uses under use (C). Hardness dependent metal ranges based upon hardness range of 25-400 mg/L
- (2) DWS come from the ADEC Alaska Water Quality Criteria Manual – Table I, the ADEC Water Quality Standards under use (A)(i), and EPA Primary Drinking Water Standards.
- (3) Ammonia CALC limit dependant on calculated lowest 5<sup>th</sup> percentile of temperature and pH. Ranges provided are based upon a pH range of 6.5 - 9.0 and temperature of 0 - 30 °C; 0.179-6.67 early stages of fish present, 0.442-10.8 early stages not present
- (4) Cadmium, Chromium III, Copper, Lead, Nickel and Zinc CALC limits are dependent on Hardness lowest 5th percentile.
- (5) Criterion given is for free cyanide. ADEC has determined that the WAD cyanide method is to be used for analysis and the result is to be applied to the free cyanide criterion.
- (6) Criterion given is the more stringent of those available for chromium III and chromium VI. Analysis is of total chromium.
- (7) The Criterion given for total mercury concentration is based on the Alaska Water Quality Criteria Manual for Toxic and Other Deleterious Organic and Inorganic Substances, 2002.
- (8) Criterion given is an acute criterion, rather than a chronic criterion. No chronic aquatic life criterion has been established for silver.

References:

State of Alaska, Department of Environmental Conservation, Alaska Water Quality Criteria Manual for Toxic and Other Deleterious Organic and Inorganic Substances, as amended through December 12, 2008.  
 State of Alaska, Department of Environmental Conservation, 18 AAC 70, Water Quality Standards, amended as of Sep. 19, 2009  
 40 CFR Part 60.

### *Process Description*

The water treatment process removes non-soluble metals and suspended solids using chemical coagulation, flocculation, clarification and greensand filtration. TSF water will be pumped into a sand-ballasted clarifier system. The sand ballast will provide a dense seed for any metal precipitates to bond with in the mix tanks. The metal precipitates that form on the sand particles will be routed to an integral hydrocyclone that will separate the sand from the sludge. The sand will be recycled back to the mix tanks while the sludge will be deposited in the TSF.

With its modular design, the clarifier will be shipped as a complete unit to eliminate on-site fabrication. It can be housed indoors due to its compact size.

Chemical addition will include both a coagulant and metal precipitant to remove soluble and non-soluble metals and metalloids. The type of coagulant may include a ferric or ferrous iron to enhance metal adsorption and an organic sulphur metal precipitation chemical or a polymer with an organic sulphur group that complexes and agglomerates soluble metals into a crystal precipitant at a neutral pH. Addition of this type of metal precipitant has proven very effective at removing elements, such as selenium at a relatively neutral pH. Use of this type of metal precipitant is relatively new in the industrial water treatment industry, but has proven itself for low-level (e.g. at levels below 0.005 mg/L) selenium removal at mine WTPs. Flocculant will also be used to increase the particulate size in the water column. The selection of the coagulant, metal precipitant, and flocculant types will be determined in subsequent phases of WTP planning. The discharge from the WTP will meet the most stringent water quality standard under EPA and State of Alaska regulations.

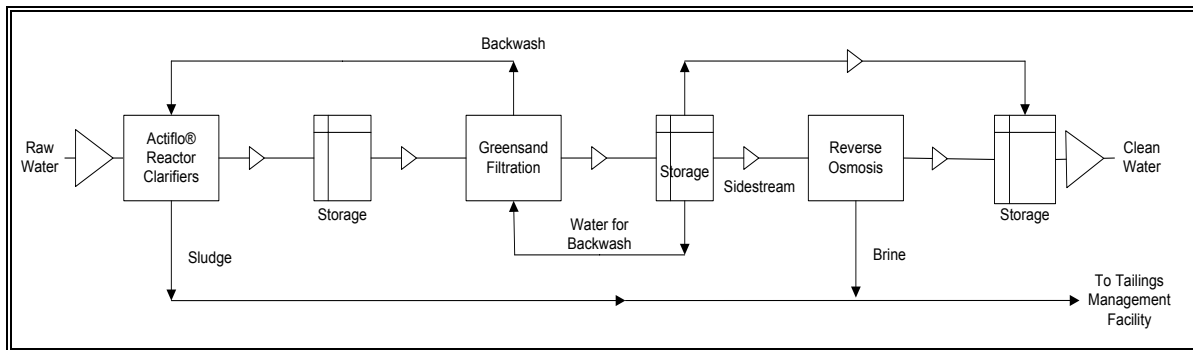
Clarified water will be routed into a storage tank that will feed a greensand filter pump skid. Water will be pumped from the storage tank to pressure vessels containing greensand filter media. The media's physical characteristics will act to filter metal precipitates from the clarifier overflow.

After treating a specific amount of water, the filtration capacity will reduce due to the capture of particulates in the clarifier overflow. Filtered water will be used to periodically backwash the filter media, one filter at a time. Backwash water containing metal precipitates will be recycled back to the clarifier for treatment and subsequent removal in the clarifier sludge. Over time, the oxidation capacity of the greensand media will be consumed and media regeneration will be conducted. Filtered water will be routed to a mixing/holding tank. From this tank, treated water will be routed to the discharge location.

At mine year 5, a low energy, single pass reverse osmosis (RO) membrane process will be added to the WTP for sulphate and TDS removal. A portion of filtered water will be routed through the RO system and the RO permeate will be routed to the effluent mixing tank to achieve the overall required discharge limits. It will then mix with the filtered water that bypasses the RO system. The mixed water will be routed to the surface discharge. The RO concentrated brine will be routed to the TSF. Water quality modelling conducted to date indicates the combined contributions of RO brine and WTP sludge will have a negligible effect on TSF water quality.

An overall process flow schematic is shown in Figure 18.3.7.

**Figure 18.3.7 Process Flow Block Diagram for Mine Water Treat System**



### Waste Disposal

The clarifier sludge and RO brine concentrate from the WTP will be routed to the TSF for disposal. The clarifier sludge will consist of precipitated metal oxides, hydroxides, and oxy-hydroxides in crystalline and non-crystalline forms. The clarifier sludge is expected to be between 0.5% and 1.5% solids by weight. The WTP influent chemistry is not a good candidate for producing high-density sludge in the clarifier (i.e. greater than 3-4% solids) due to very low concentrations of metals, especially iron. The clarifier sludge will be stable in that the metals will not re-dissolve in the TSF unless the TSF pH drops to such low levels that certain metal solubility limits are reached. However, in the unlikely event that these metals do re-dissolve, they will then be routed to the WTP and removed from solution in the treatment process.

## 18.4 SUSTAINABILITY

---

### 18.4.1 PROJECT SETTING

#### JURISDICTIONAL SETTING

The Pebble Project is located in Alaska – a progressive, developed-country jurisdiction with a constitution that encourages resource development, and a citizenry that broadly supports such development. The state has a strong tradition of hardrock mining. Recently permitted mines include:

- Red Dog, the world’s largest zinc mine (1984);
- Fort Knox (1994);
- Pogo (2003);
- Greens Creek (2005);
- Kensington (2005); and
- Rock Creek (2006, 2007).

Environmental standards and permitting requirements in Alaska are stable, objective, rigorous and science-driven. These features are an asset to projects like Pebble that are being designed to meet international best practice standards of design and performance. The State has an experienced Large Mine Permitting Team to facilitate the permitting process, and in particular to ensure an integrated strategy for federal and state permitting.

Moreover, the Pebble deposit is located on State land that has been specifically designated for mineral exploration and development. The project area has been the subject of two comprehensive land-use planning exercises, the first in the 1980s and the second completed in 2005. There are five land parcels within the Bristol Bay Area Plan (including Pebble) that have been identified as containing “significant mineral potential,” and where the planning intent is to accommodate mineral exploration and development. These parcels total 2.7% of the total planning area.

#### ENVIRONMENTAL AND SOCIAL SETTING

The Pebble deposit is located under rolling, permafrost-free terrain in the Iliamna region of southwest Alaska, approximately 200 miles southwest of Anchorage, 17 miles northwest of the villages of Iliamna and Newhalen, and 60 miles west of tidewater on Cook Inlet (Figure 18.4.1 and Figure 18.4.2). The deposit area and access corridor are isolated and sparsely populated. They lie almost completely within the Lake and Peninsula Borough, which has a population of about 1,500 persons in 17 communities (Figure 18.4.1). In the deposit area, the closest communities include three villages – Iliamna, Newhalen and Nondalton – about 17 miles from the deposit site, and another – Pedro Bay – along the access corridor to the port site. None has more than 250 full-time residents. There are local roads in the Iliamna/Newhalen/Nondalton area, a summer road between Williamsport and Pile Bay, and summer barges up the Kvichak River and on Iliamna Lake. The airport at Iliamna provides the only year-round access to and from the area.

The main population centers of the region lie on Bristol Bay, approximately 130 miles southwest of the deposit. Collectively, the communities of Dillingham, Naknek, South Naknek, and King Salmon have approximately 4,000 residents. The total population within a 150-mile radius of the Pebble deposit is approximately 5,000. More information on the socio-political context of the project area is found in Section 18.4.7.

Several periods of glaciation have rounded the topography and filled the valley bottoms with glacial debris, moraines and lake-bottom sediments (Figure 18.4.3 to Figure 18.4.5). The surface elevation over the deposit ranges from approximately 800 to 1,200 ft amsl, although mountains in the region reach 3,000 to 4,000 ft amsl.

Figure 18.4.1 Pebble Project Location – Southwest Alaska

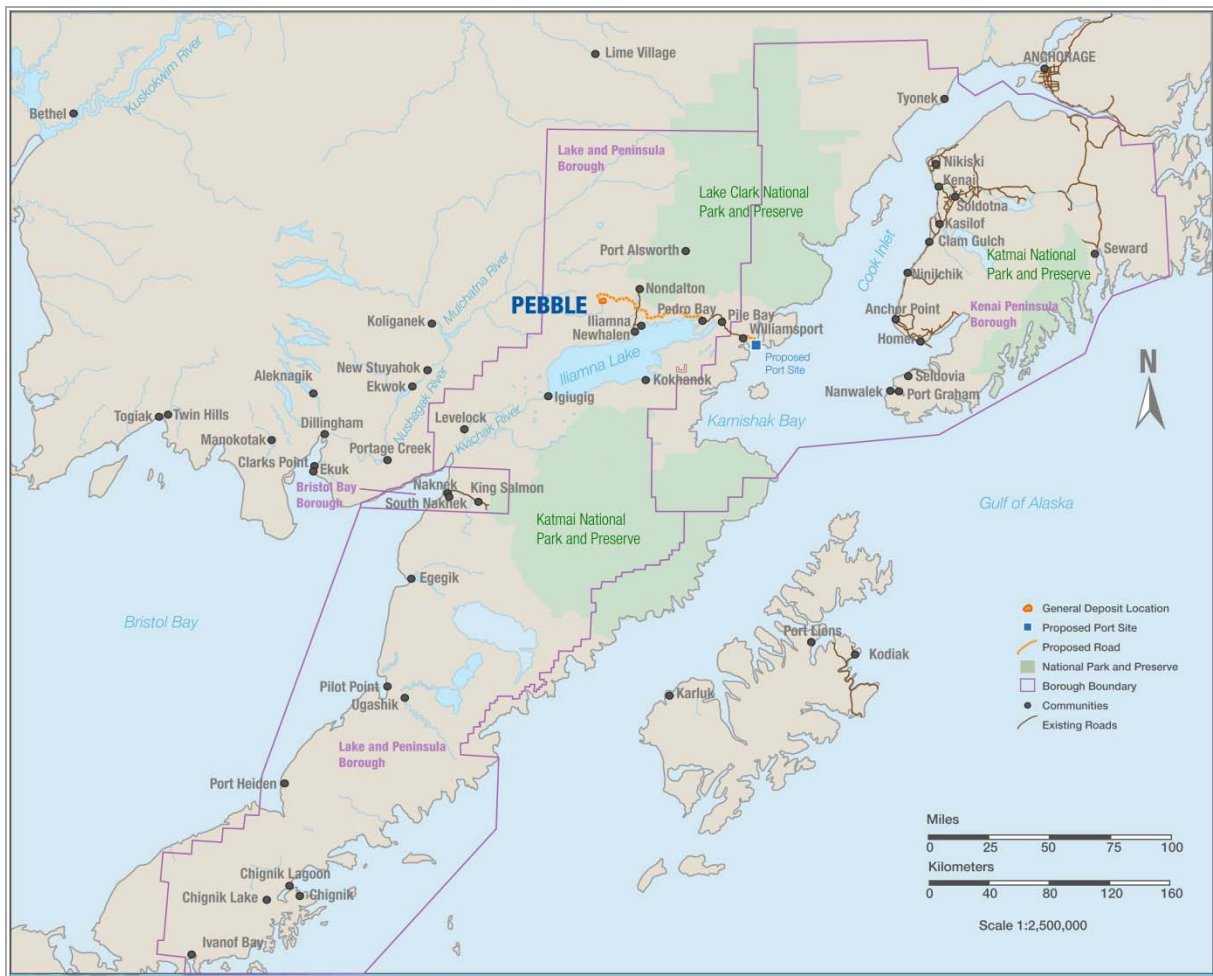


Figure 18.4.2 Pebble Project Access Corridor



1056140100-REP-R0001-00

Figure 18.4.3 Pebble Deposit Area – Looking North

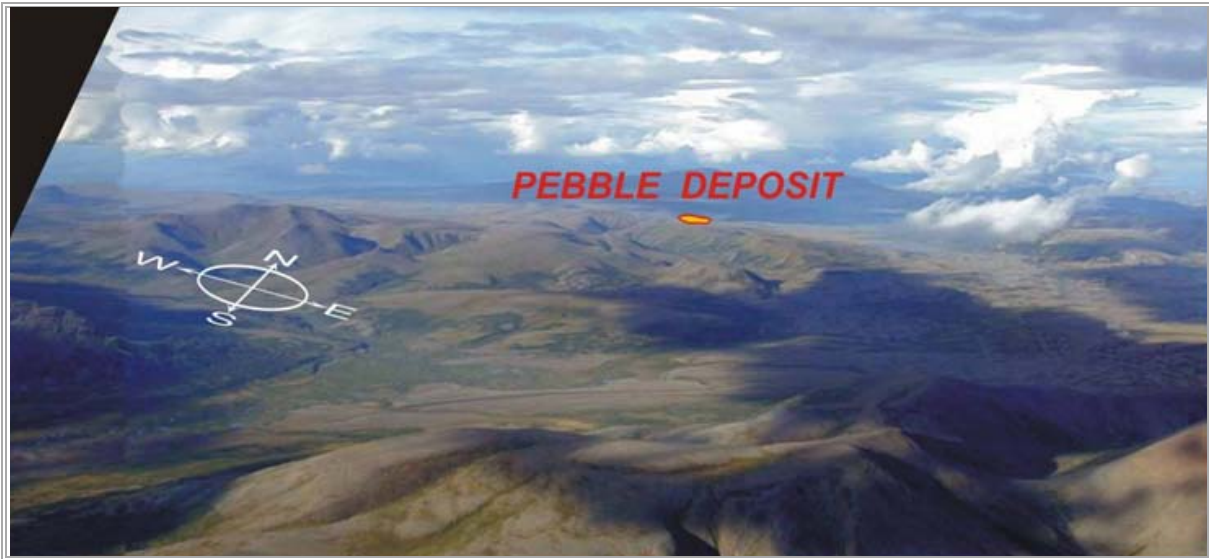
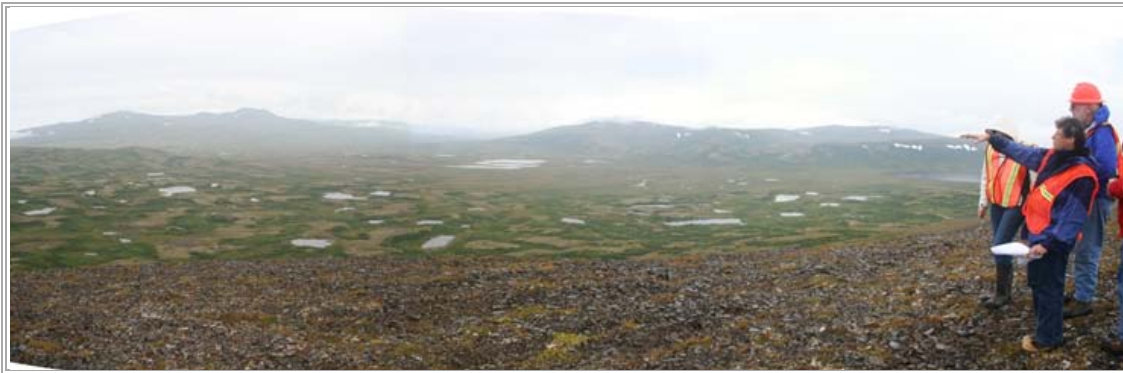


Figure 18.4.4 Pebble Site Topography – Looking Northwest





**Figure 18.4.5 Pebble Site Topography – Looking East**



Topographically, the proposed access corridor from the deposit site to Cook Inlet crosses the Newhalen River (Figure 18.4.6) and parallels the north shore of Iliamna Lake. It crosses terrain similar to that in the deposit area for approximately 60 road miles (Figure 18.4.2) until reaching steeper hillsides near the village of Pedro Bay (Figure 18.4.7). After crossing gentler terrain around the northeast end of Iliamna Lake, the corridor crosses the Aleutian Range along the route of an existing road to tidewater at Williamsport (Figure 18.4.8). From there it crosses Iliamna Bay and follows the coastline to the port site on Iniskin Bay, off Cook Inlet (Figure 18.4.9).

**Figure 18.4.6 Proposed Newhalen River Crossing Site – Looking Downstream to the South**



Figure 18.4.7 Pedro Bay



Figure 18.4.8 Williamsport, Looking Inland to the West



**Figure 18.4.9 Port Site 1, Looking Northeast into Iniskin Bay**



The climate in the deposit area is transitional; it is more continental in the winter because of frozen waterbodies and sea ice in Bristol Bay, and more maritime in the summer due to the influence of the open water of Iliamna Lake and, to a lesser extent, the Bering Sea, Bristol Bay and Cook Inlet. Mean monthly temperatures range from about 55°F (13°C) in July/August to 2°F (-17°C) in March. In the deposit area, precipitation averages approximately 54 inches per year, about one-third of which is realized as snow. The wettest months are August through October. White-out conditions and wind storms or periods of poor light/visibility can be expected in winter. Vegetation generally consists of wetland and scrub communities with some coniferous and deciduous forested areas that become more common eastwards toward the Aleutian Range.

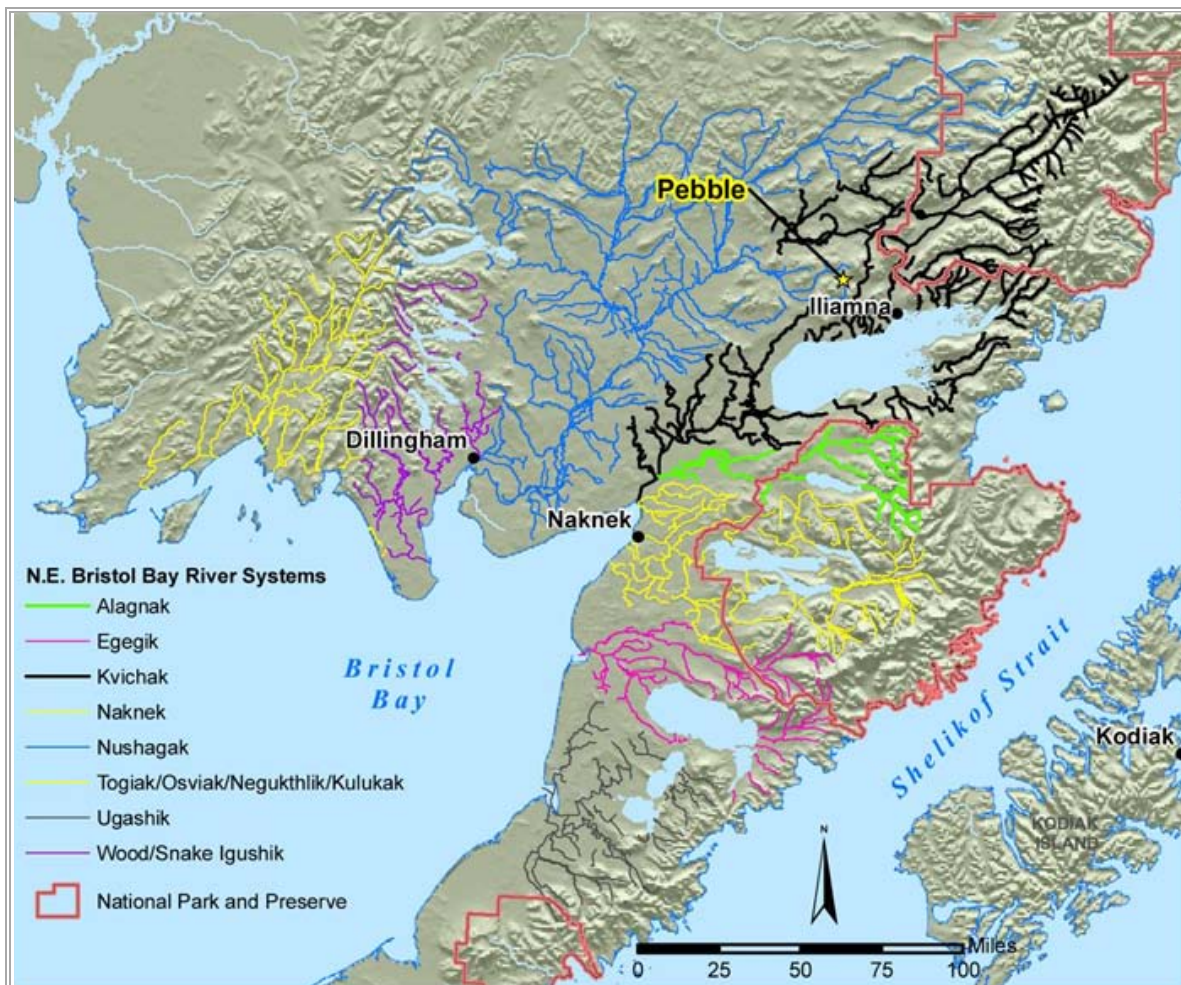
Hydrologically, the deposit area lies at the top of the Koktuli River (North and South Forks) and Upper Talarik Creek drainages. The Koktuli River is tributary to the lower Mulchatna River, which drains via the lower Nushagak River to Bristol Bay at Dillingham, some 220 river miles southwest of the deposit area (Figure 18.4.10). Upper Talarik Creek flows into Iliamna Lake, which in turn drains into Bristol Bay via the Kvichak River some 140 river/lake miles to the southwest.

The Kvichak and Nushagak river systems are two of eight major systems that drain into Bristol Bay and support significant sockeye salmon runs, as well as other species of salmon. This sockeye population supports important commercial, subsistence and sport fisheries. To put the fisheries importance of the

Pebble Project area in context, government studies (e.g. Alaska Department of Fish and Game, Fishery Management Report No. 10-25, 2009) indicate that, over the past decades, the entire Kvichak and Nushagak-Mulchatna river systems have together contributed about 20-30% of total Bristol Bay sockeye salmon production. Thus, some 70-80% of Bristol Bay sockeye production is hydrologically isolated from any potential effects of the Pebble Project. The area of the Kvichak and Nushagak-Mulchatna river systems total more than 22,000 square miles, of which only about 400 square miles, or about 1.8%, is comprised of the project watersheds of the North and South Fork Koktuli Rivers, and Upper Talarik Creek. Based on several years of field studies by the Pebble Partnership, and other government studies (e.g. ADF&G 2009 above), it is estimated that these three watersheds generally produce less than 0.5% of the total Bristol Bay sockeye run (harvest plus escapement).

Other wildlife using the deposit area includes various species of raptors and upland birds, brown bear, caribou and moose. Four species listed under the Endangered Species Act – Steller’s Eider, Sea Otter, Steller’s Sea Lion, and the Cook Inlet Beluga Whale – have been observed near the proposed port site, as have harbour seals, a species protected under the Marine Mammals Protection Act.

Figure 18.4.10 Bristol Bay Watersheds



## 18.4.2 PROJECT PERMITTING

The permitting approach for the Pebble Project is designed with an awareness of the rigorous mine permitting process in Alaska, the environmental and social sensitivities of the project area, and the business realities of working in the state. It is based on a fundamental risk management approach – identify, study and manage. It has a number of key dimensions, all of which are important to its success.

Most important, is the development of a clear, concise and comprehensive understanding of state and federal permitting laws, regulations and procedures. Pebble initiated these investigations early on, and they continue to be refined as precedents with other projects develop.

Another foundation of the Pebble Partnership’s approach to permitting is thorough, comprehensive and robust scientific research within the project area. This is vital to: (i) characterize the project setting, especially all key sensitivities to mine development; (ii) provide effective environmental and social input to the project design; and (iii) prepare an optimized, environmentally responsible project design for permitting. Pebble has undertaken baseline environmental and social studies (Section 18.4.4) that are unprecedented in Alaska, employing high-quality consultants and scientific methods.

Another key dimension to Pebble’s permitting approach is environmentally driven project design and decision making to ensure the project meets corporate commitments to responsible mineral development, and is ready for successful permitting (Section 18.4.3).

A key to timely permitting is early and continuing engagement with state and federal agencies that will have permitting roles. This engagement ensures that agency personnel are thoroughly familiar with the scale and depth of environmental studies undertaken for the project, understand the study results, and are prepared for an efficient start to the permitting process. The Pebble Partnership started this engagement early on. To date, the engagement process has involved numerous meetings, participation in technical working groups, and presentations of annual work plans and results. Joint work programs have also been undertaken to provide needed project information and opportunities to work closely with agencies to achieve shared objectives, as well as to enhance public confidence in the information being used for project planning. For example, the Pebble Partnership supported the U.S. Geological Survey (USGS) to establish standard hydrological stations on all three deposit area watercourses, and the Alaska Department of Fish and Game (ADF&G) to carry out surveys of subsistence activities in communities near the Pebble Project.

Stakeholder engagement is also key to creating the conditions for responsible project design and efficient permitting. Again, this engagement began early for Pebble, and continues as described in Section 18.7.9. The Pebble Partnership has long recognized that stakeholder engagement is vital to the development of a thorough understanding of community concerns and aspirations so they can be reflected in project design (Section 18.4.3). Engaging community organizations in environmental study programs (Section 18.4.8) has been a core activity to provide opportunities for local training, employment and relationship building, while enhancing public confidence in the information being used for project planning.

Efficient permitting also requires ongoing, comprehensive assessment of project alternatives to ensure that the Pebble Project is optimized from a technical, financial, environmental and social perspective. Evaluation of alternatives is integral to mine permitting in Alaska, and Pebble is ensuring that all reasonable alternatives are being considered. To date, these investigations have included alternate road alignments, port site locations, mine plans including tailings and waste rock storage methods and locations, and power supply methods and locations (Section 18.4.3).

Implementing a multi-dimensional permitting program for the Pebble Project requires a strong, Alaska-based team. The Pebble Partnership has attracted senior, experienced staff to lead project development and permitting. John Shively, a long-time Alaska business leader, joined the Pebble Partnership as CEO in early 2008. Mr. Shively was formerly Commissioner of the Alaska Department of Natural Resources (DNR), President of the Resource Development Council of Alaska, and a senior executive with NANA Corporation – the Alaska Native Regional Corporation that partnered with Teck Cominco in the development and operation of the state’s largest mine, Red Dog. Other notable Alaskans who have been recruited into leadership positions with the Pebble Partnership include:

- Ken Taylor - Vice President, Environment. Mr. Taylor worked as a wildlife biologist in the State of Alaska for more than 30 years, most recently as Deputy Commissioner of ADF&G. He spent 10 years as a senior biologist in the region of southwest Alaska in which Pebble is located.
- Mike Heatwole - Vice President, Public Affairs. Mr. Heatwole is a long-time Alaskan communications professional with experience in private industry, government and consulting including eight years as Director of Public Affairs with the Alyeska Pipeline Service Company.

#### STATE AND FEDERAL PERMITTING

The Pebble Project must satisfy permitting requirements at three levels: federal, state, and local (borough). Though these requirements are extensive, they are also stable, objective, rigorous and science-based. These features are an asset to projects like Pebble that are designed to meet international best practice standards for design and performance. A thorough knowledge of permitting requirements and process is contributing to the environmental design of Pebble, and to ensuring it is well positioned for successful permitting. The State of Alaska has an experienced Large Mine Permitting Team to facilitate the permitting process (Figure 24.12), especially by ensuring an integrated approach to federal and state permitting.

Permitting for water withdrawal, fish passage, wetlands and cultural resources has been ongoing at Pebble throughout the exploration phase. Based on the experience of Pebble Partnership staff and others with mine projects in Alaska, and maximum review periods allowed in regulations, mine permitting is expected to take about three years to complete. Permitting will involve 10 or more regulatory agencies, approximately 65 categories of permits (Table 18.4.1), and significant opportunities for public involvement. A Pebble Mine Permitting Plan has been prepared that provides a list of required permits and environmental plans, and the information required to prepare applications and support documents.

**Table 18.4.1 Pebble Project Permits**

Category	Agency
<b>Major permits</b>	
<b>Overall project</b>	
Detailed Construction and Operation Description	All
Plan of Operations Approval	ADNR
Coastal Project Consistency Determination	ADNR
<b>Project Design</b>	
<b>Dam Safety</b>	
Certificate of Approval to Construct a Dam	ADNR
Certificate of Approval to Construct a Dam	ADNR
<b>Reclamation</b>	
Reclamation Plan Approval	ADNR
<b>Water</b>	
<b>Water Discharge</b>	
Section 402 National Pollutant Discharge Elimination System (NPDES) Water Discharge Permit	EPA or ADEC
Certificate of Reasonable Assurance (Section 401)	ADEC
Non-Domestic Wastewater Disposal Section of Waste Management Permit	ADEC
Plan Review for Non-Domestic Wastewater Treatment System	ADEC
Plan Review and Construction Approval for Domestic Sewage System	ADEC
<b>Storm Water</b>	
Storm Water Construction and Operation Permit	EPA
Storm Water Discharge Pollution Prevention Plan	EPA/ADEC
<b>Underground Injection</b>	
Underground Injection Control Well	EPA
<b>Water Use</b>	
Temporary Water Use Permit	ADNR
Permit to appropriate Water	
<b>Air Quality</b>	
Air Quality Control Permit to Construct, either: Prevention of Significant Deterioration (PSD), or minor permit	ADEC
Title V Operating Permit	
<b>Fill/Material Use And Placement</b>	
<b>Wetland Fills</b>	
Section 404 Permit for Discharge of Dredge or Fill Materials into Waters of the U.S., including wetlands	COE
Section 404 Permit Review	EPA
Certificate of Reasonable Assurance (Section 401)	ADEC
<b>Solid Waste Disposal (Landfills, Waste Rock, and Tailings)</b>	
Solid Waste Disposal Section of Waste Management Permit	ADEC
<b>Construction in or over Navigable Waters</b>	
Section 10 Permit for Construction of any Structure in or Over any Navigable Waters of the US	COE

Table continues...

...Table 18.4.1 (cont'd)

Category	Agency
Construction Permit for a Bridge or Causeway Across Navigable Waters	USCG
Navigation Lighting and Marking Aids Permit	USCG
<b>Material Sale</b>	
Material Sale on State Land	ADNR
<b>Land Use</b>	
<b>State Land</b>	
Upland Mining Lease	ADNR
Mill Site Permit	ADNR
Tidelands Lease	ADNR
Lease of Other State lands	ADNR
Miscellaneous Land Use Permit	ADNR
Road Right of Way	ADNR
Power Line Right of Way	ADNR
Pipeline Right of Way	ADNR
<b>Cultural Resources Protection</b>	
Section 106 Historical and Cultural Resources Protection	EPA/COE
Cultural resources Authorizations	ADNR
<b>Local Government</b>	
Lake and Peninsula Borough Development Permit	L&PB
<b>Oil Spill</b>	
Spill Prevention, Control, and Countermeasure Plan	EPA
Oil Discharge Prevention and Contingency Plan	ADEC
Facility Response Plan	EPA
Facility Response Plan	USCG
<b>Fish and Wildlife Protection</b>	
Fish Habitat Permit	ADFG
Fish Passage Permit	
Bald Eagle Protection Act Clearance	USFWS
Migratory Bird Protection	
Threatened & Endangered Species Act (ESA) Consultation (Section 7)	USFWS & NMFS
<b>Minor Permits</b>	
<b>Hazardous Materials and Wastes</b>	
Hazardous Waste Generator (Resource Conservation and Recovery Act [RCRA]) Identification Number	EPA
Hazardous Materials Registration Number	USDOT
Approval to Transport Hazardous Materials	ADPS
<b>Air Quality Permit to Open Burn</b>	
Burn Permit	ADNR
Burn Permit	ADEC
<b>Mine Safety</b>	
Miner Training and Retraining Plan Approval	MSHA
Mine Identification Number	

table continues...



...Table 18.4.1 (cont'd)

Category	Agency
Notification of Legal Identity	
<b>Marine Safety</b>	
Hazardous Cargo	USCG
Fuel Offloading	
Person in Charge Certification	
<b>Security</b>	
Port Security Operations Plan	DHS
Port Facility Security Coordinator Certification	
<b>Public Health and Safety</b>	
Approval to Construct and Operate a Public Water Supply System	ADEC
Food Sanitation Permit	
Life and Fire Safety Plan Check	ADPS
State Fire Marshall Plan Review Certificate of Approval for Each Bldg.	ADOL
Certificate of Inspection for Fired and Unfired Pressure Vessel	
<b>Explosives</b>	
License to Transport Explosives	BATF
Permit and License for Use of Explosives	
Notice of Controlled Firing Area for Blasting	FAA
<b>Aviation</b>	
Notice of Proposed Construction or Alteration	FAA
Highway Transportation	ADOT/PF
Utility Permit on Right of Way	
Driveway Permit	
<b>Communications</b>	
Radio License	FCC
<b>Registrations</b>	
Employer Identification Number	ADOL
Mining License	ADNR

**Federal Permitting:** When the Pebble Partnership initiates the permitting process, it will submit a Project Description, an Environmental Baseline Document (Section 18.4.4) and a preliminary draft federal permit application. For Pebble, this will likely be a U.S. Army Corps of Engineers (USACE) 404 wetlands permit, whose submittal will trigger the National Environmental Policy Act (NEPA). NEPA requires that an Environmental Impact Statement (EIS) be prepared by a third-party contractor under the direction of a lead federal agency (most likely the USACE). The EIS will provide: i) the government and the public with an independent environmental analysis of the proposed project and project alternatives; and ii) federal and state agencies with important environmental information to consider during permitting. The NEPA EIS process does not provide project approval but, through associated Records of Decision for each federal permit, provides guidance to agencies for permitting.

**State Permitting:** The Alaska Department of Natural Resources Large Mine Permitting Team (LMPT) is responsible for coordinating state permitting activities for large mining projects in the State. Federal agencies may also join the LMPT. Northern Dynasty and subsequently the Pebble Partnership have

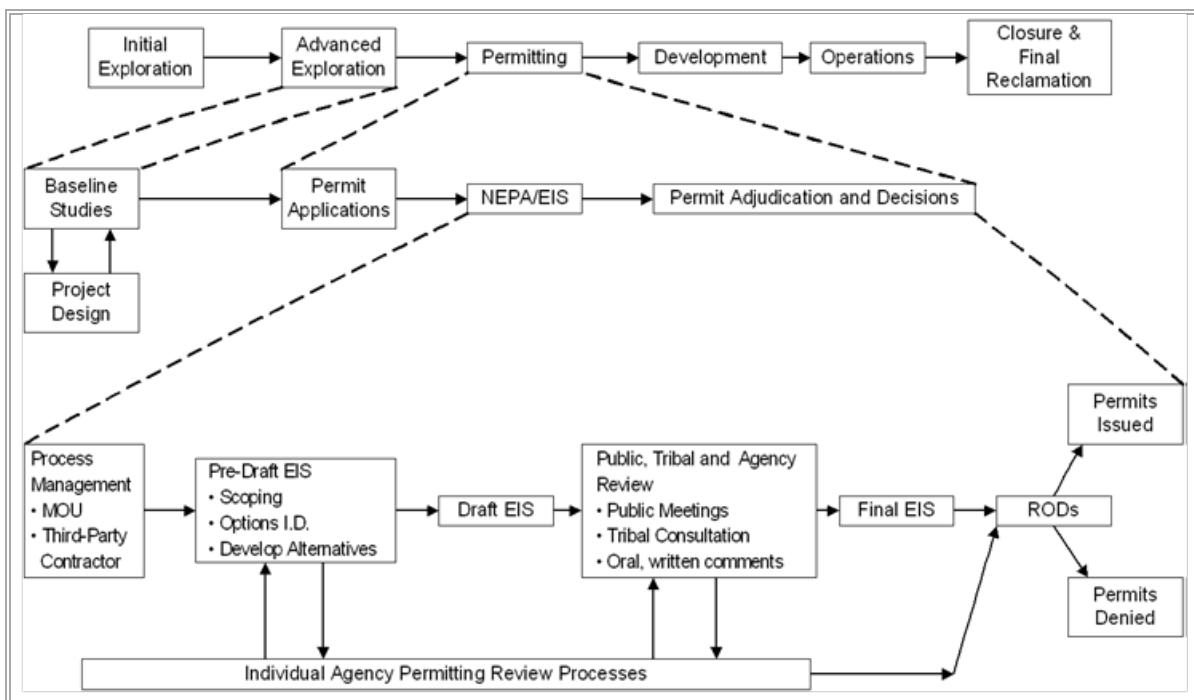
been interacting with the LMPT since 2004 in preparation for project permitting. The LMPT will become more formally engaged when the Pebble Partnership submits and discusses a proposed Project Description with the LMPT at ‘pre-permitting’ meetings. Concurrent with the NEPA review, the Pebble Partnership will prepare and submit a combined packet of state permit applications to the LMPT. After public review of these permit applications, and LMPT response to public comment, the agencies will prepare draft permits. Both the draft EIS and the draft permits require public review; these reviews will occur concurrently if the permits and EIS are ready in a reasonably similar time frame. Otherwise they will occur as separate events.

The EIS, Records of Decision for the federal permits, and the federal and state permits themselves will be finalized according to individual agency schedules.

Associated with permitting are regulatory requirements to provide compensatory mitigation for any residual impacts to wetlands, fish and wildlife. These regulations require the Pebble Partnership to make reasonable efforts to avoid or minimize impacts before considering mitigation projects (e.g. replacement wetlands for those lost to the mine) or financial compensation. The avoidance and minimization of residual environmental impacts has been a key focus of environmental study, design and planning programs at Pebble. For unavoidable residual impacts, a provisional amount for compensatory mitigation projects has been included in the project financial analysis.

It should be noted that no decision has been taken by the Pebble Partnership to seek permits for the project as described in this Preliminary Assessment. The Project Description that the Pebble Partnership ultimately elects to submit for permitting under NEPA may vary in a number of ways.

**Figure 18.4.11 Typical Mining Project Flow Diagram**



### 18.4.3 KEY ENVIRONMENTAL ISSUES AND DESIGN DRIVERS

The key environmental and social issues associated with the Pebble Project were identified early on by Northern Dynasty, and have shaped baseline data collection, environmental and social analysis and input to project design, and continuing stakeholder consultations ever since. This has been a central and constant theme in the ongoing drive to ensure that the Pebble Project meets high corporate standards for responsible mineral development, as well as rigorous permitting standards.

A 1993 independent scoping and assessment of environmental issues at the Pebble Project undertaken when Cominco was project operator provided a comprehensive starting point. In 2005, the Nushagak-Mulchatna Watershed Council provided a comprehensive list of its questions. Northern Dynasty provided responses to all of these questions based on the stage of project design at the time. The Pebble Partnership is expected to further respond to the Nushagak-Mulchatna Watershed Council's questions when the Pebble Project design is finalized for permitting. These documents, the experience of senior Northern Dynasty and Pebble Partnership staff, early and ongoing stakeholder consultations, and early identification of permitting requirements have all contributed to thorough identification and management of environmental and social project risks.

A comprehensive approach is being taken to identify, study, and manage all of these issues through project planning and design. However, baseline studies and impact analyses at the Pebble Project have focused on key environmental 'drivers' of the Pebble Project design:

- water – quantity and quality of surface and groundwater;
- wetlands – especially those designated as 'jurisdictional' and subject to USACE Section 404 permitting;
- aquatic habitats – especially for salmon and trout;
- air quality; and
- marine environment – especially protected species and consequences for construction and operations planning.

In addition, the Pebble Project is being planned to accommodate the social sensitivities of establishing a large industrial facility in an isolated, sparsely populated region. The project is being planned to maximize local benefits – such as employment, infrastructure development and new business opportunities – while minimizing potential disruptions to traditional lifestyles and avoiding adverse effects on existing resource-based industries.

Before a decision is made to initiate permitting, the Pebble Partnership will undertake a comprehensive suite of environmental and social impact analyses, and an Environmental and Social Impact Assessment. These will provide a rigorous, science-based analysis to demonstrate that the project will meet permitting requirements in Alaska, as well as international best practice for project development. Such analyses by a mine developer are not required in the USA under the federal NEPA permitting process.

#### 18.4.4 BASELINE STUDIES

Together, key project design drivers and rigorous mine permitting requirements in Alaska, as well as a corporate commitment to meet international best practice for responsible mineral development, has driven the need for substantial studies of the environmental and social setting of the project, as well as intensive development of stakeholder relations. Over the 2004-2010 period, these studies have cost more than \$150 million and have resulted in an environmental and socioeconomic database that is unprecedented in Alaska in terms of its comprehensiveness and depth. The studies have encompassed the deposit area, the transportation corridor to Cook Inlet, the marine environment in the area of potential port sites (Figure 18.4.12), as well as the broader project region. The studies have been designed to:

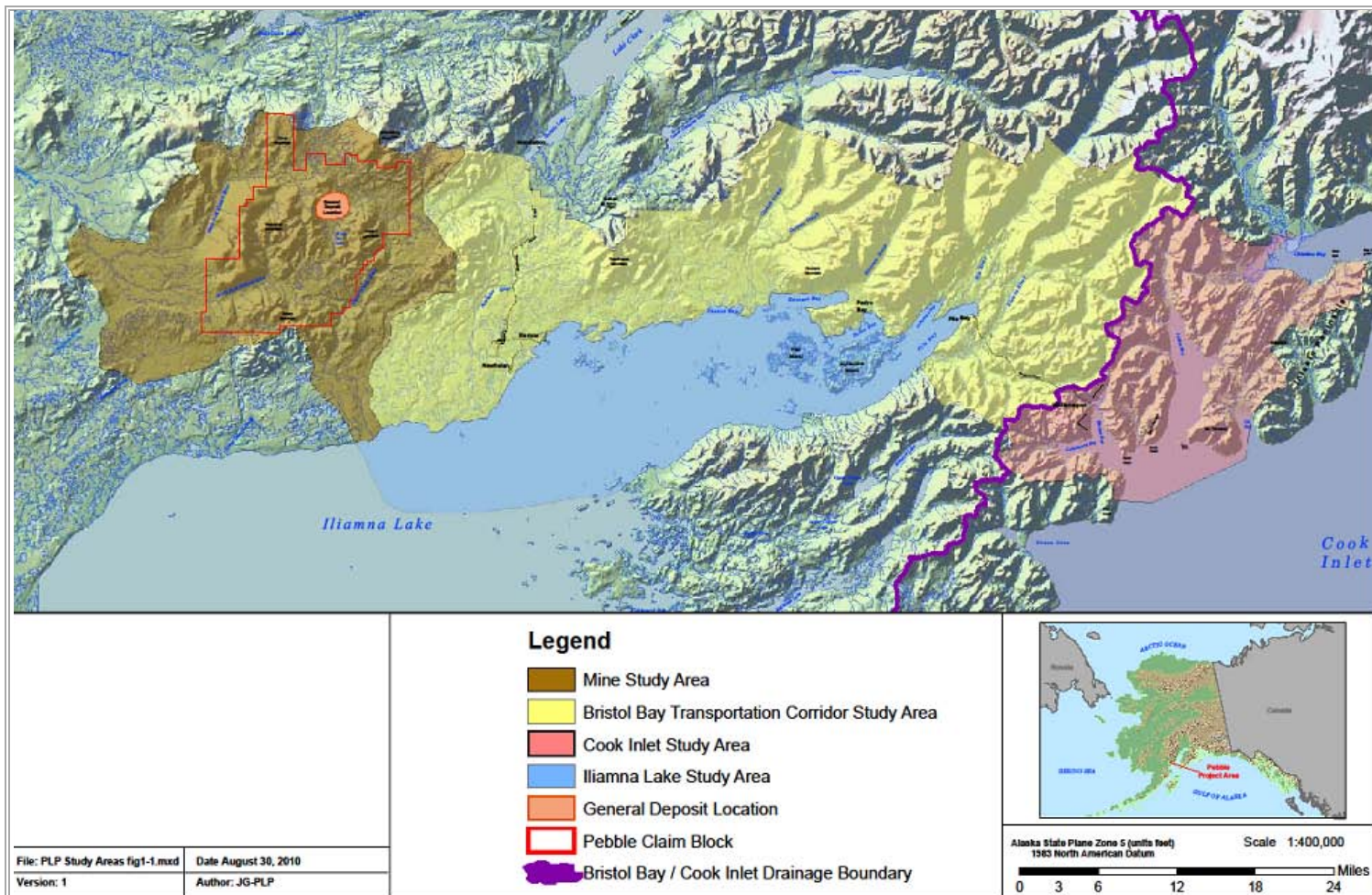
- fully characterize the existing biophysical and socioeconomic environment;
- support environmental analyses required for effective input into project design;
- provide a strong foundation for internal environmental and social impact assessment to support corporate decision-making; and
- provide the information required for stakeholder consultation and eventual mine permitting in Alaska.

In terms of its comprehensiveness, the baseline study program includes:

- surface water
- water quality
- groundwater
- geochemistry
- snow surveys
- fish and aquatic resources
- noise
- wetlands
- trace elements
- flow habitat
- Iliamna Lake
- marine
- wildlife
- air quality
- cultural resources
- subsistence
- land use
- recreation
- socioeconomics
- visual aesthetics.

Northern Dynasty and subsequently the Pebble Partnership have worked closely with relevant federal and state agencies since 2004 to ensure their input is reflected in the environmental study program, and that agency personnel are knowledgeable about the project, the project area and existing environmental conditions prior to the initiation of permitting. Detailed annual study plans have been submitted to the appropriate Alaska and federal agencies; study results, both annual and cumulative, have been presented to and discussed with the agencies each year until 2008. All baseline data have been subjected to a rigorous quality assurance and quality control program. The baseline studies program has employed the skills of a number of highly qualified consulting firms in the US and Canada (Table 18.4.2).

Figure 18.4.12 General Pebble Project Study Areas



**Table 18.4.2 Environmental Baseline Study Consultants**

Subject	Firm	Location
Surficial Geology	T.D. Hamilton, PhD	Anchorage, AK
Geochemistry	SRK Consulting	Vancouver, BC
Hydrology; Water Management	Knight Piésold Consulting	Vancouver, BC
Groundwater	Schlumberger Water Services	Richmond, BC
Air Quality and Meteorology	Hoefler Consulting Group	Anchorage, AK
Wetlands	Three Parameters Plus Inc.	Palmer, AK
	HDR	Anchorage, AK
Wildlife	ABR Inc.	Anchorage, AK
Fish & Aquatic Resources Oversight	Bailey Environmental	Oregon City, OR
	Buell & Associates	Portland, OR
Fish & Aquatic Resources & Habitat Modelling	R2 Resource Consultants	Anchorage, AK; Brush Prairie, WA
Marine Studies	Pentec Environmental	Edmonds, WA
Trace Elements	SLR Alaska	Anchorage, AK
Cultural, Subsistence & Traditional Knowledge	Stephen R. Braund & Associates	Anchorage, AK
Land Use And Recreation	Kevin Waring & Associates	Anchorage, AK
Visual Aesthetics	Land Design North	Anchorage, AK
Socioeconomics	McDowell Group	Juneau & Anchorage, AK

The Pebble Partnership is currently documenting the 2004-2008 study results in a multi-volume Environmental Baseline Document (EBD) to support the NEPA EIS permitting process. The EBD is scheduled for completion in early 2011. A table of contents for the EBD is given in Table 18.4.3. Altogether, it is expected to comprise some 20,000 pages of text, tables, figures and maps, plus a comprehensive electronic database, which will be made publicly available on CD.

Since 2008, Pebble has been releasing a series of summary data reports as part of its public information program (see <http://pebblepartnership.com/environment/data-releases>). There are now 14 pre-permitting environmental/socioeconomic data reports:

- Meteorology;
- Surface Water Hydrology;
- Surficial Geology;
- Groundwater Hydrology;
- Trace Elements - Soils and Sediments;
- Surface Water Quality;
- Naturally Occurring Constituents;
- Macroinvertebrates and Periphyton;
- Marine Habitats;
- Nearshore Fish and Benthic Invertebrates;
- Noise;
- Iliamna Lake Studies;
- Visual Resources; and
- Terrestrial Wildlife and Habitats.

Some of the key baseline study programs are summarized below.

**Table 18.4.3 Environmental Baseline Document Table of Contents (Page 1 of 2)**

1.	<b>INTRODUCTION</b>	10.3	Fish Tissue—Mine Study Area
1.1	Drainages	10.4	Soil and Vegetation— Transportation Corridor
1.2	Environments	10.5	Sediment — Transportation Corridor
	<b>BRISTOL BAY DRAINAGES</b>	10.6	Fish Tissue— Transportation Corridor
2.	<b>CLIMATE AND METEOROLOGY</b>	10.7	Iliamna Lake
2.1	Region	11.	<b>GEOCHEMICAL CHARACTERIZATION</b>
2.2	Mine Study Area	12.	<b>NOISE</b>
2.3	Transportation Corridor	13.	<b>VEGETATION</b>
3.	<b>GEOLOGY AND MINERALIZATION</b>	13.1	Mine Study Area
3.1	Region	13.2	Transportation Corridor
3.2	Mine Study Area	14.	<b>WETLANDS</b>
3.3	Transportation Corridor	14.1	Mine Study Area
4.	<b>PHYSIOGRAPHY</b>	14.2	Transportation Corridor
4.1	Region	15.	<b>FISH AND AQUATIC INVERTEBRATES</b>
4.2	Mine Study Area	15.1	Fish Resources—Mine Site
4.3	Transportation Corridor	15.2	Macroinvertebrates and Periphyton—Mine Site
5.	<b>SOILS</b>	15.3	Fish Resources—Transportation Corridor
5.1	Region	15.4	Macroinvertebrates and Periphyton—Transportation Corridor
5.2	Mine Study Area	15.5	Zooplankton - Iliamna Lake
5.3	Transportation Corridor	16.	<b>WILDLIFE AND HABITAT</b>
6.	<b>GEOTECHNICAL AND SEISMIC</b>	16.1	Habitat Mapping – Mine Study Area
6.1	Region	16.2	Terrestrial Mammals – Mine Study Area
6.2	Mine Study Area	16.3	Raptors – Mine Study Area
6.3	Transportation Corridor	16.4	Waterbirds – Mine Study Area
7.	<b>SURFACE WATER HYDROLOGY</b>	16.5	Breeding Birds – Mine Study Area
7.1	Region	16.6	Habitat Mapping – Transportation Corridor
7.2	Mine Study Area	16.7	Terrestrial Mammals – Transportation Corridor
7.3	Transportation Corridor	16.8	Iliamna Lake Harbor Seals
8.	<b>GROUNDWATER HYDROLOGY</b>	16.9	Raptors – Transportation Corridor
8.1	Mine Study Area	16.10	Waterbirds – Transportation Corridor
8.2	Transportation Corridor	16.11	Breeding Birds – Transportation Corridor
9.	<b>WATER QUALITY</b>	16.12	Wood Frogs – Mine Study Area
9.1	Surface Water – Mine Study Area	17.	<b>THREATENED AND ENDANGERED SPECIES</b>
9.2	Groundwater – Mine Study Area	18.	<b>LAND AND WATER USE</b>
9.3	Surface Water – Transportation Corridor	19.	<b>TRANSPORTATION</b>
9.4	Groundwater – Transportation Corridor	20.	<b>POWER SOCIOECONOMICS</b>
9.5	Surface Water –Iliamna Lake	21.	<b>CULTURAL RESOURCES</b>
10.	<b>TRACE ELEMENTS</b>	22.	<b>SUBSISTENCE AND TRADITIONAL KNOWLEDGE</b>
10.1	Soil and Vegetation—Mine Study Area	23.	<b>VISUAL RESOURCES</b>
10.2	Sediment—Mine Study Area	24.	<b>RECREATION</b>

Table continues...

Table 18.4.3 (cont'd)

<b>COOK INLET DRAINAGES AND MARINE</b>		<b>APPENDICES</b>
25.	<b>CLIMATE AND METEOROLOGY</b>	A. Analytical Data QA/QC
26.	<b>GEOLOGY</b>	B. Iliamna Lake Studies
27.	<b>PHYSIOGRAPHY</b>	C. Data Management
28.	<b>SOILS</b>	D. Chemical Abbreviation
29.	<b>GEOTECHNICAL, SEISMIC AND VOLCANISM</b>	E. Consolidated Study Program
30.	<b>SURFACE WATER HYDROLOGY</b>	F. Consolidated Field Sampling Plans
31.	<b>GROUNDWATER HYDROLOGY</b>	G. Quality Assurance Project Plan
32.	<b>SURFACE WATER QUALITY - FRESHWATER</b>	
33.	<b>OCEANOGRAPHY AND MARINE WATER QUALITY</b>	
	33.1 Physical Oceanography	
	33.2 Marine Water Quality	
34.	<b>TRACE ELEMENTS</b>	
	34.1 Soil and Vegetation	
	34.2 Freshwater Sediment	
	34.3 Freshwater Fish Tissue	
	34.4 Marine	
35.	<b>MARINE HABITATS</b>	
36.	<b>NOISE</b>	
37.	<b>TERRESTRIAL VEGETATION</b>	
38.	<b>TERRESTRIAL WETLANDS</b>	
39.	<b>FRESHWATER FISH AND AQUATIC INVERTEBRATES</b>	
	39.1 Freshwater Fish	
	39.2 Aquatic Invertebrates	
40.	<b>TERRESTRIAL WILDLIFE AND HABITAT</b>	
	40.1 Habitat Mapping	
	40.2 Mammals	
	40.3 Raptors	
	40.4 Waterbirds	
	40.5 Breeding Birds	
41.	<b>MARINE BENTHOS</b>	
42.	<b>NEARSHORE FISH AND INVERTEBRATES</b>	
43.	<b>MARINE WILDLIFE</b>	
44.	<b>THREATENED AND ENDANGERED SPECIES</b>	
45.	<b>LAND AND WATER USE</b>	
46.	<b>TRANSPORTATION</b>	
47.	<b>POWER</b>	
48.	<b>SOCIOECONOMICS</b>	
49.	<b>CULTURAL RESOURCES</b>	
50.	<b>SUBSISTENCE AND TRADITIONAL KNOWLEDGE</b>	
51.	<b>VISUAL RESOURCES</b>	
52.	<b>RECREATION</b>	



## BASE MAPPING

To enable accurate location and analysis of the baseline data collected for project planning and design, extensive base mapping of the Pebble Project area has been undertaken using air photography and LiDAR to create orthophoto maps and digital elevation models (Figure 18.4.13). The mapping covers all areas in which project infrastructure options have been, or are being, considered, as well as areas where it was considered important to document existing environmental conditions.

## METEOROLOGY

Seven meteorological stations – six in the deposit area and one at the potential port site – are being operated to gather data for both project design and permitting. Collected data include wind speed and direction, air temperature, solar radiation, barometric pressure, relative humidity, precipitation and, in summer, evaporation.

## SURFACE HYDROLOGY

Extensive hydrological field studies have been undertaken to support both mine water balance calculations and determine the amount and type of aquatic habitats in deposit area watercourses at different times of the year. These studies began in the early 1990s, and most data have been collected since 2004. The studies involve:

- 29 continuously operated gauging stations in five watersheds – the North and South Fork Kaktuli rivers, Upper Talarik Creek, Kaktuli River and Kaskanak Creek (Figure 18.4.14):
  - three operated by the USGS
  - six operated by Alaska Peninsula Corporation Services
  - 20 operated by Pebble consultants;
- More than 125 instantaneous flow measurement sites recording:
  - base flows (for groundwater model calibrations)
  - water quality
  - fisheries instream flow (Figure 18.4.15); and
- Scheduled monthly field visits to 42 sites, including:
  - all 29 continuously gauged stations (rating curve development)
  - 13 water quality stations.

## GROUNDWATER

The groundwater study program at Pebble has been similarly extensive (Table 18.7.4) to support detailed water balance calculations and stream flow modelling. It includes:

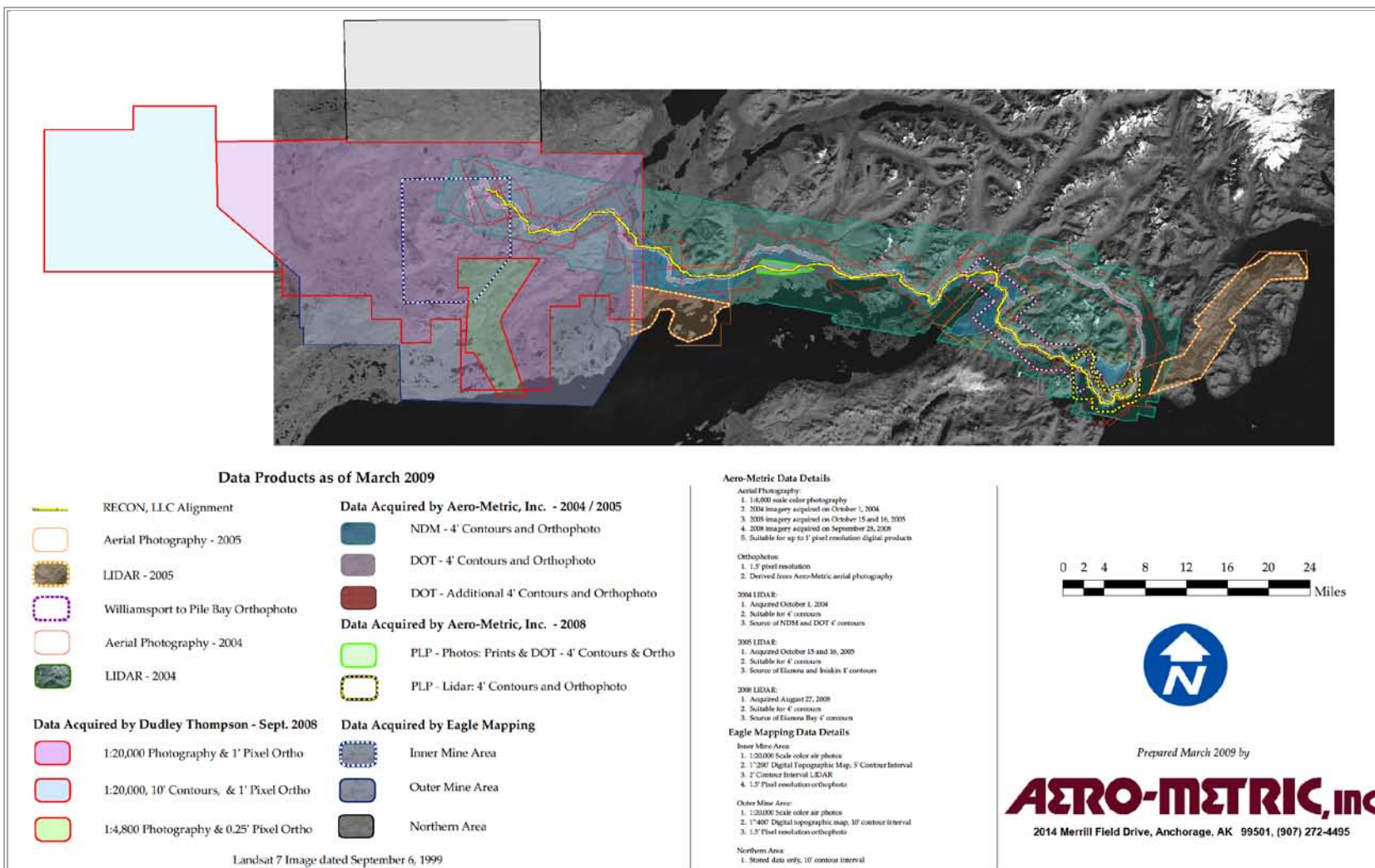
- drill circulation monitoring in the deposit area;
- seep inventory and monitoring;
- low flow stream gauging to provide an understanding of low flow regimes, of groundwater discharge to streams and areas of loss of stream flow to groundwater;
- installation of piezometers and monitoring wells (Table 18.4.4);
- well development and response testing of piezometers and monitoring wells;
- installation of pumping wells and pumping tests;
- monthly measurements of groundwater levels; and
- Westbay deep hole measurements.

## WATER QUALITY

The water quality study program at Pebble has encompassed:

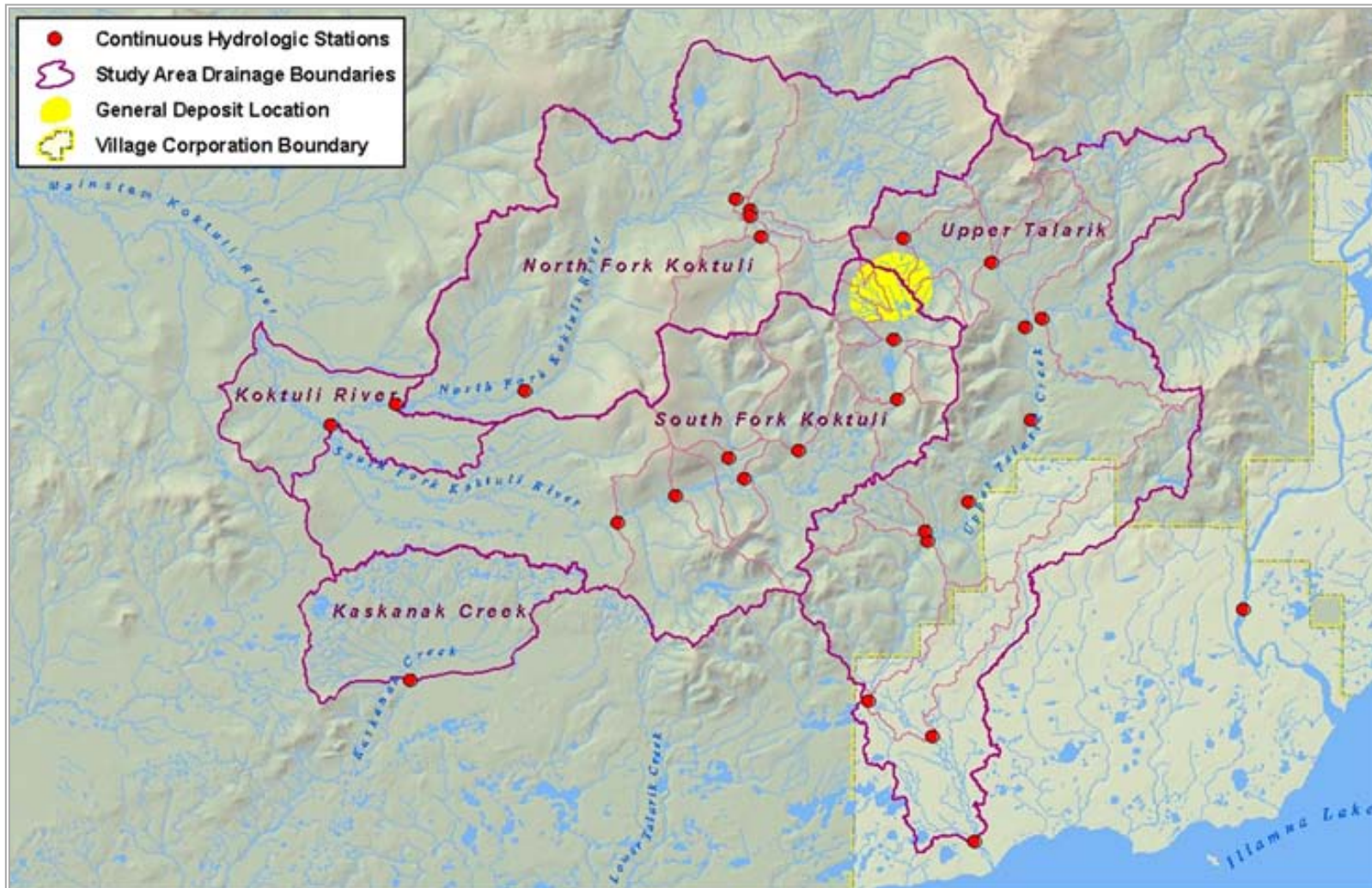
- Mine Study Area (Figure 18.4.16):
  - five years of water quality data
  - 49 sampling events at 20 – 38 stations (individual sites typically have 20 – 49 sample sets each)
  - monthly sampling frequency from May – October in 2004, 2005 and early 2006 with two winter sampling events, changing to monthly year-round sampling in late 2006; and
- Access Corridor:
  - two-year sampling effort (2004-2005)
  - 340 sample sets
  - six stations sampled on 12 occasions
  - another 18 stations sampled 1 - 6 times each year
  - characterization of the potential road corridor general area.

Figure 18.4.13 Pebble Project Spatial Data Index



1056140100-REP-R0001-00

Figure 18.4.14 Continuous Hydrologic Gauging Stations



1056140100-REP-R0001-00

Figure 18.4.15 Daily Mean Flow in Deposit Area Streams with Life Stage Periods for Salmon

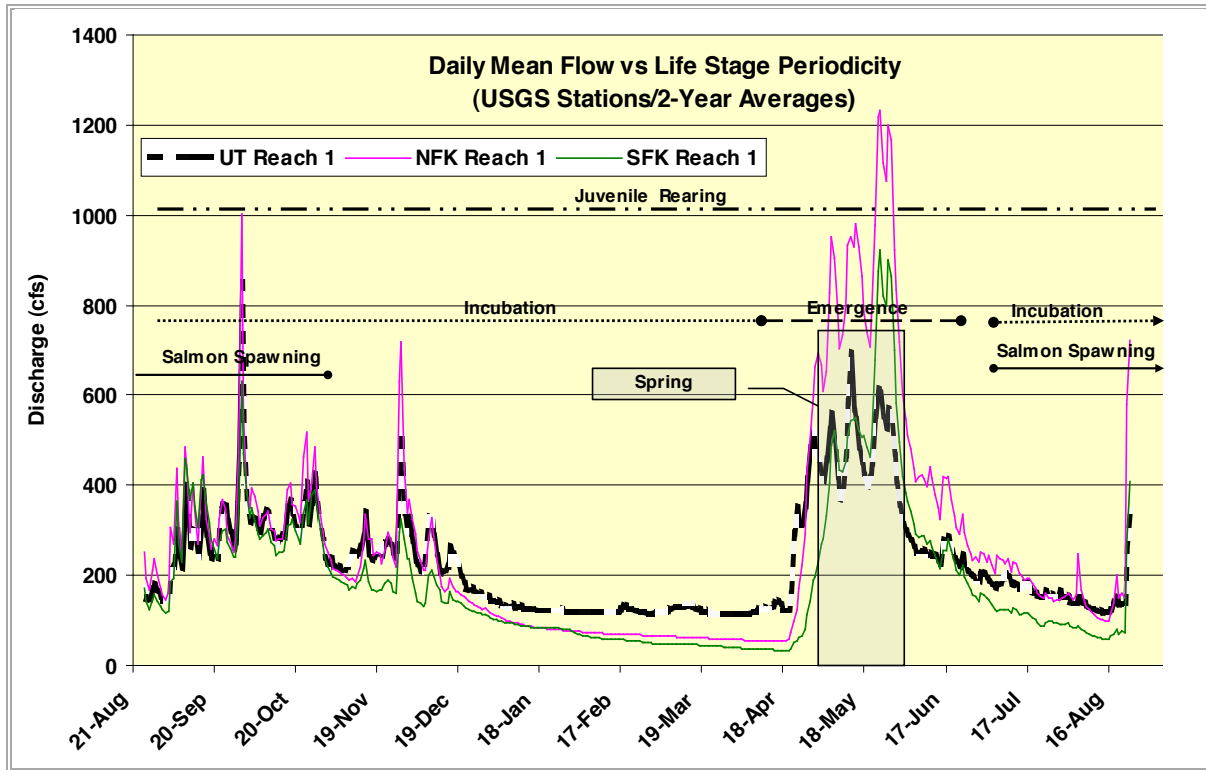


Table 18.4.4 Summary of Groundwater Investigations

Description	2004	2005	2006	2007	2008	Total
Pumping Wells	3	4	-	-	2	9
Pump Tests	3	4	-	-	2	9
Response Tests	31	63	10	2	-	106
Geotechnical Response Tests	42	-	-	-	101	143
Packer Tests	51	32	-	118	241	442

Table 18.4.5 Summary of Piezometer Investigations

Description	2004	2005	2006	2007	2008	Total
South Fork Kaktuli in Deposit Area	31	31	6	8	26	102
South Fork Kaktuli Remainder	37	41	3	-	61	142
North Fork Kaktuli	12	1	4	29	70	116
Upper Talarik	6	11	13	5	27	62
Small Pools Study	-	21	-	29	-	50
<b>Total</b>	<b>86</b>	<b>105</b>	<b>26</b>	<b>71</b>	<b>184</b>	<b>472</b>

## WETLANDS

The extensive wetlands study program at Pebble, in both the deposit area (Figure 18.4.17) and along the access corridor, has two major purposes:

- the delineation of wetland units – field data collection, data quality control and validation, line drawing, polygon coding, and field review; and
- the functional classification of delineated wetland units.

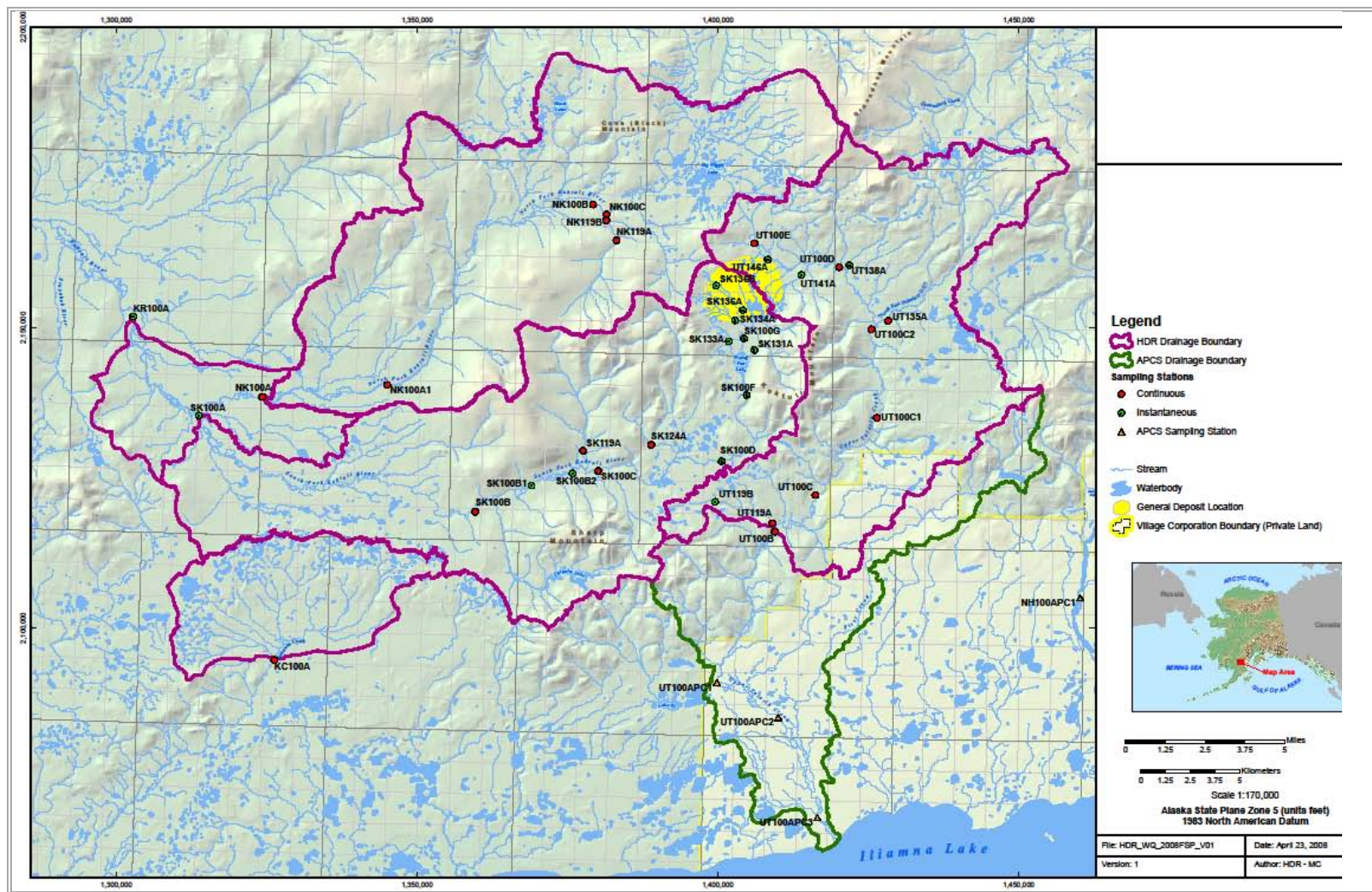
In the Pebble deposit area, the total number of plots assessed for wetlands characteristics exceeded 5,000 as of 2008 (Figure 18.4.17).

## AQUATIC HABITAT AND RESOURCES

Extensive aquatic habitat studies were initiated in 2004, and have continued annually with different scopes, study areas and levels of effort as the information base grew and specific data needs become more defined. Studies have been carried out in the three main deposit area drainages – the North and South Fork Koktuli rivers, Upper Talarik Creek and their tributaries – the Koktuli River, along the access corridor, and in and around Iliamna Lake. Completed studies include:

- fish population and density estimates using various field methods (dip netting, electro-fishing, snorkelling and aerial surveys) (Figure 18.4.18 to Figure 18.4.21);
- fish habitat studies (main- and off-channel transects, habitat preferences);
- spring spawning counts and radio telemetry for rainbow trout;
- overwintering studies for salmon, trout and grayling;
- radio telemetry of arctic grayling to assess stream fidelity;
- Frying Pan Lake northern pike population estimate;
- fish habitats/assemblages above Frying Pan Lake;
- salmon escapement estimates;
- geo-referenced video aquatic habitat mapping;
- intermittent flow reach, habitat and fish use; and
- fish tissue measurements for trace metals.

Figure 18.4.16 Pebble Project Area Water Quality Sampling Stations



1056140100-REP-R0001-00

Figure 18.4.17 Pebble Project Area Wetlands Study Areas

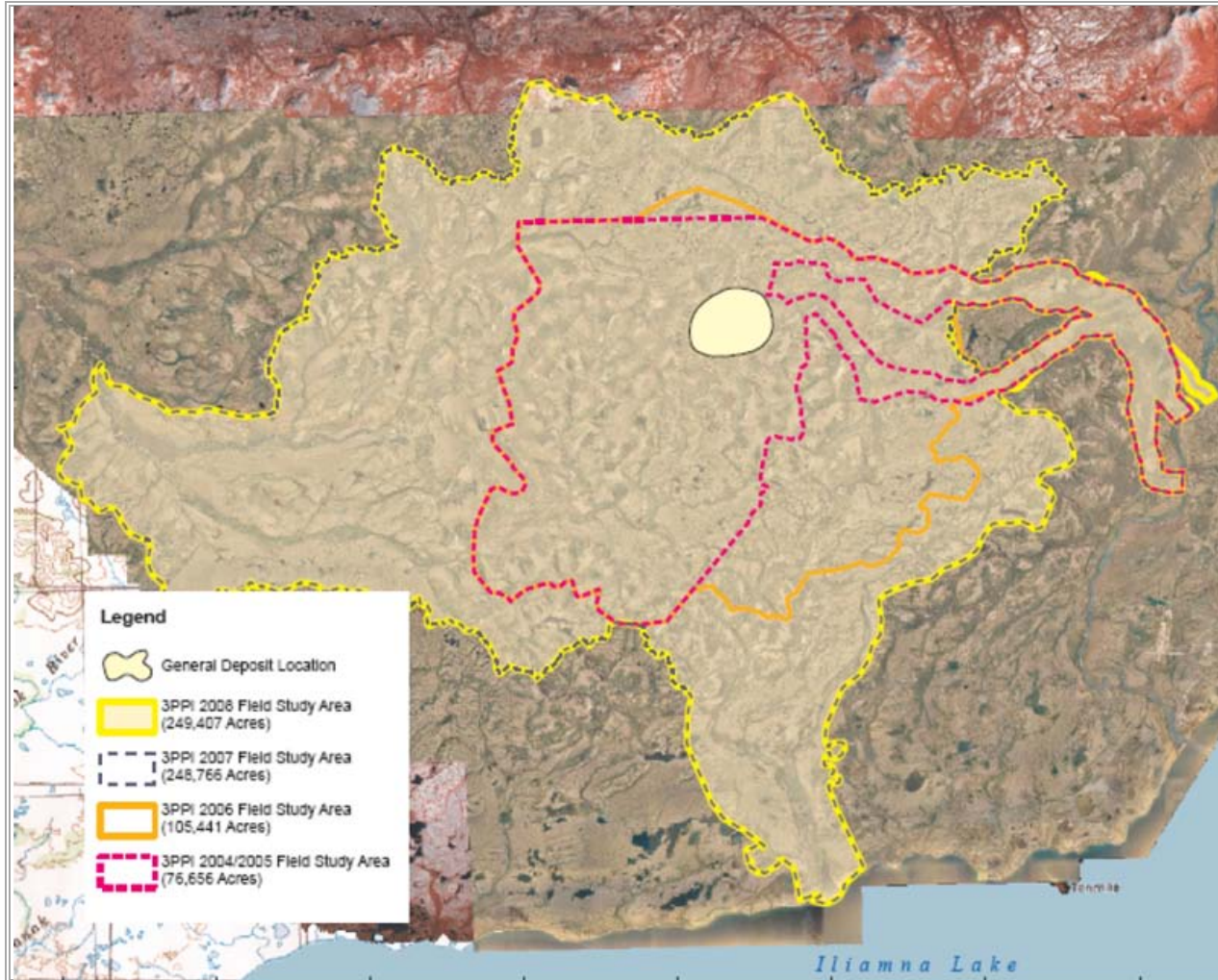
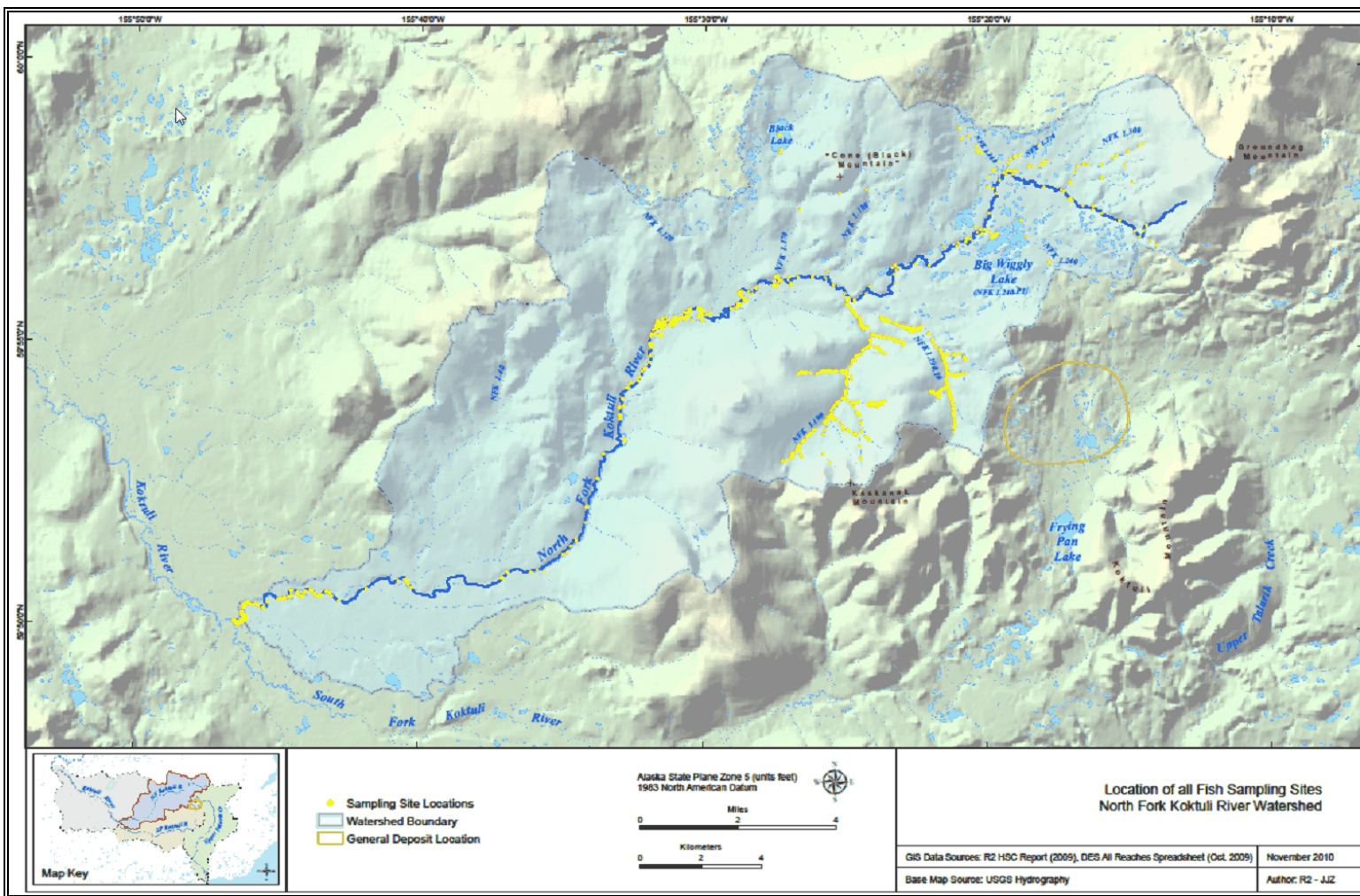




Figure 18.4.18 Fish Sampling Sites on the North Fork Koktuli River



1056140100-REP-R0001-00

Figure 18.4.19 Fish Sampling Sites on the South Fork Koktuli River

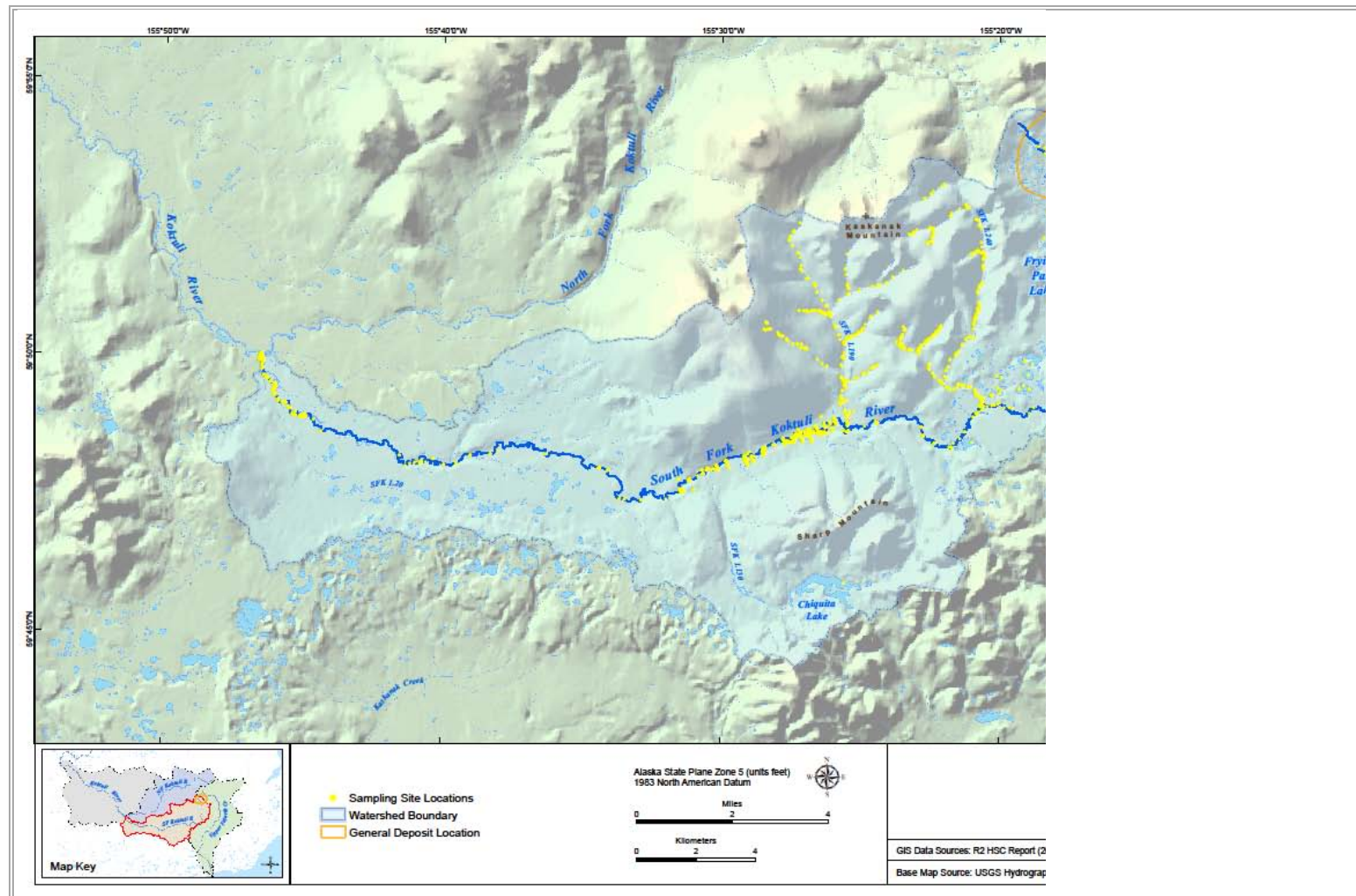


Figure 18.4.20 Fish Sampling Sites on Upper Talarik Creek

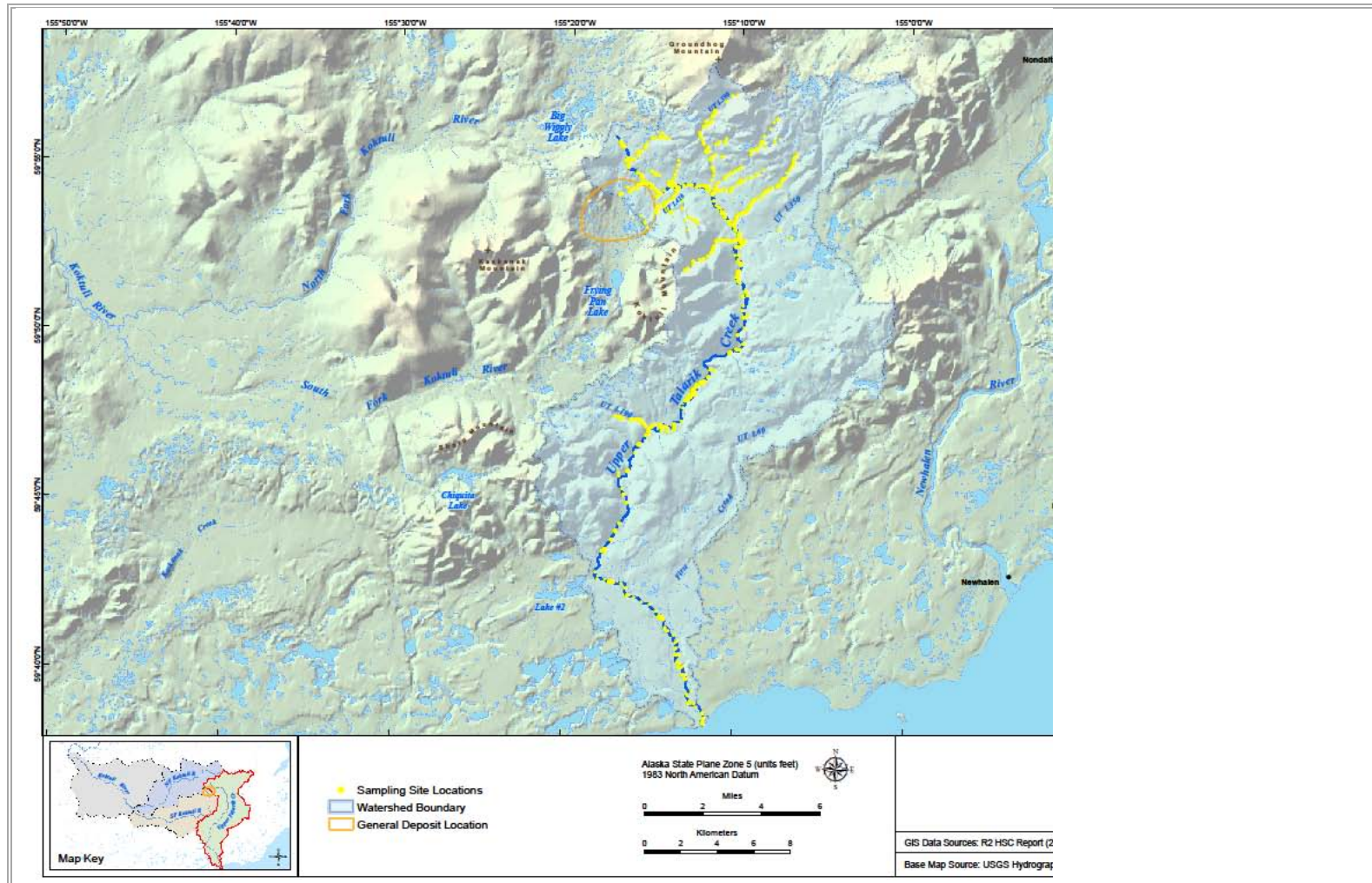
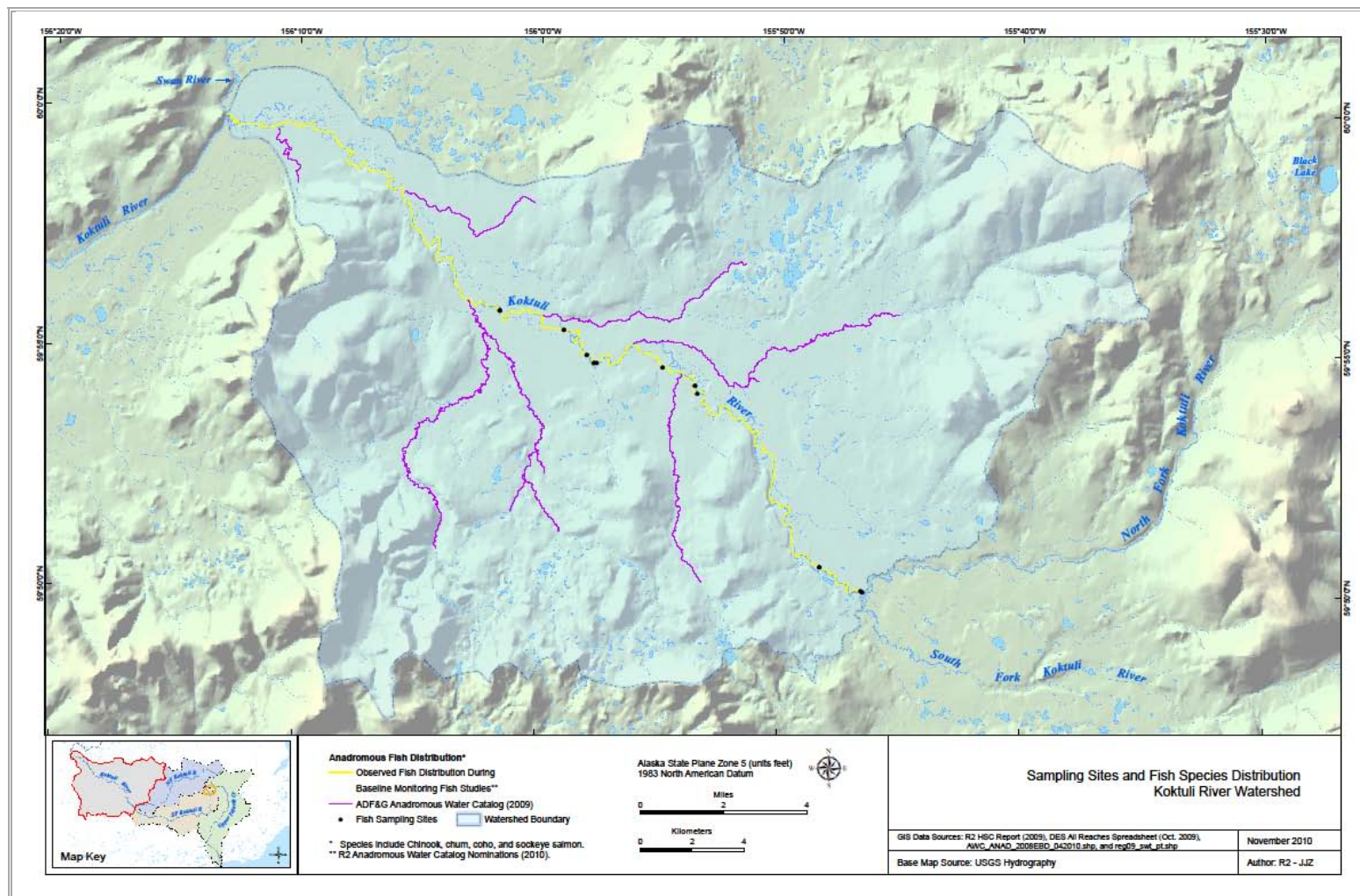


Figure 18.4.21 Fish Sampling Sites on the Kaktuli River



## ENVIRONMENTAL DOCUMENTS

Over the course of the baseline study program, a wide variety of environmental documents have been produced for program planning and for communicating program plans and results to federal and state agencies in Alaska. They include:

- study plans – 2004, 2005, 2006, 2007, 2008’;
- field sampling plans – 2005, 2006, 2007, 2008’;
- quality assurance plans – 2005, 2006, 2007, 2008’;
- baseline data progress report – 2004;
- data management audit reports – 2007;
- Environmental Baseline Studies, Executive Summary – 2007; and
- agency presentations of field programs and findings – 2004, 2005, 2006, 2007, 2008.

### 18.4.5 ENVIRONMENTAL ANALYSES AND INPUT TO PROJECT DESIGN

Based on the identification of key design ‘drivers’ discussed above, as well as future impact assessment and permitting needs, Northern Dynasty and subsequently the Pebble Partnership have undertaken comprehensive baseline studies and impact analyses to support a growing understanding of the project environment and to develop environmental design guidance for engineering work. A comprehensive identification of project features and activities that may cause environmental or social impacts has been developed. These include:

- potential reductions in flows in drainages within the deposit area;
- generation and storage of potentially acid-generating (PAG) tailings and waste rock;
- quality of surplus mine water and treatment requirements;
- loss of wetlands within the project footprint;
- location and use of the access road through now relatively isolated communities and over anadromous fish streams;
- construction and operation of the road/port in marine habitats; and
- closure and reclamation.

Close liaison between the project engineering and environmental teams has facilitated ongoing environmental analysis and input to the engineering design, on the general issues listed above and on more specific topics as needed by the design team (e.g. discharge water quality standards, construction timing windows).

For example, it is planned to:

- site the tailings storage facility (TSF) away from important fish habitat;
- treat excess mine water before discharge in order to meet the most stringent of regulated water quality standards in Alaska (Table 18.4.6);
- sustain or enhance aquatic habitats in the project area through carefully scheduled releases of treated discharge water and, if needed, implementing supplemental habitat enhancement measures;
- store PAG tailings subaqueously in the TSF;
- align the access road to by-pass Pedro Bay village as much as practicable, to avoid or minimize crossing wetland areas, and to minimize the number of stream crossings;
- move concentrate to the port by pipeline rather than by road in order to limit the volume of truck traffic on the road; and,
- accommodate construction and operations workforces on a rotational basis in fly-in-fly-out camps, in part to avoid development pressures on small, proximal communities.

This work is summarized by area of risk in Table 18.4.7. It will continue through future project design phases to ensure specific risk management strategies and plans develop in parallel with the engineering design.

**Table 18.4.6 Industrial Wastewater Discharge Permit Limitations for Freshwater Discharge**

Parameter	Units	Alaska Chronic Aquatic Life Criteria	Drinking Water Standard	Most Stringent Standard
Hardness	mg/L	NA	NA	NA
pH	pH Units	>6.5 & <8.5, not >0.5 from natural	>6.0 and <8.5	>6.5 and <8.5
fecal coliform	#/100 ml		20	
Temp	°C	<13 C	<15 C	<13
Color		50	15 units	
DO	mg/L	>7 & <17, and >5 in spawning gravel	>4	>4, <17
Turbidity	NTU	25> background, lakes 5> background	5> background	5> background
Conductivity	umhos/cm	NA	NA	NA
Total Dissolved Solids	mg/L	1000	500	500
Total Suspended Solids	mg/L	NA	NA	NA
Acidity	mg/L	NA	NA	NA
Alkalinity	mg/L	>=20	NA	>=20
Nitrate/ Nitrite	mg/L	NA	10	10
Phosphorus	mg/L	NA	NA	NA
Chloride	mg/L	230	250	230
Fluoride	mg/L	NA	4	NA
Sulphate	mg/L	NA	250	250

*Table continues...*

...Table 18.4.6 (cont'd)

Parameter		Units	Alaska Chronic Aquatic Life Criteria	Drinking Water Standard	Most Stringent Standard
Total Cyanide		mg/L	NA	NA	NA
Cyanide WAD		mg/L	0.0052	0.2	0.0052
Thiocyanate		mg/L	NA	NA	NA
Ammonia		mg/L	0.179-6.67, 0.442-10.8	NA	0.179-6.67, 0.442-10.8
Aluminum (under revision)	Total	µg/L	87	NA	87
	Dissolved	µg/L	87	NA	87
Antimony	Total	µg/L	NA	6	6
	Dissolved	µg/L	NA	NA	NA
Arsenic	Total	µg/L	150	10	10
	Dissolved	µg/L	150	NA	150
Barium	Total	µg/L	NA	2000	2000
	Dissolved	µg/L	NA	NA	NA
Beryllium	Total	µg/L	NA	4	4
	Dissolved	µg/L	NA	NA	NA
Bismuth	Total	µg/L	NA	NA	NA
	Dissolved	µg/L	NA	NA	NA
Boron	Total	µg/L	NA	NA	NA
	Dissolved	µg/L	NA	NA	NA
Cadmium	Total	µg/L	0.10 - 0.76	5	0.10 - 0.76
	Dissolved	µg/L	0.88 - 0.69	NA	0.88 - 0.69
Calcium	Total	µg/L	NA	NA	NA
	Dissolved	µg/L	NA	NA	NA
Chromium	Total	µg/L	28 - 268	100	28 - 268
	Dissolved	µg/L	24 - 230	NA	24 - 230
Cobalt	Total	µg/L	NA	NA	NA
	Dissolved	µg/L	NA	NA	NA
Copper	Total	µg/L	2.9 - 30	NA	2.9 - 30
	Dissolved	µg/L	2.8 - 29	NA	2.8 - 29
Iron	Total	µg/L	1000	NA	1000
	Dissolved	µg/L	1000	NA	1000
Lead	Total	µg/L	0.54 - 19	15	0.54 - 19
	Dissolved	µg/L	0.53 - 11	NA	0.53 - 11
Magnesium	Total	µg/L	NA	NA	NA
	Dissolved	µg/L	NA	NA	NA
Manganese	Total	µg/L	NA	50	50
	Dissolved	µg/L	NA	NA	NA
Mercury	Total	µg/L	0.012	2	0.012
Molybdenum	Total	µg/L	NA	NA	NA
	Dissolved	µg/L	NA	NA	NA
Nickel	Total	µg/L	16 - 169	100	16 - 169
	Dissolved	µg/L	16 - 168	NA	16 - 168
Potassium	Total	µg/L	NA	NA	NA
	Dissolved	µg/L	NA	NA	NA

Table continues...

...Table 18.4.6 (cont'd)

Parameter		Units	Alaska Chronic Aquatic Life Criteria	Drinking Water Standard	Most Stringent Standard
Selenium	Total	µg/L	5.00	50	5.00
	Dissolved	µg/L	4.61	NA	4.61
Silicon	Dissolved	µg/L	NA	NA	NA
Silver	Total	µg/L	0.37 - 44	NA	0.37 - 44
	Dissolved	µg/L	0.31 - 37	NA	0.31 - 37
Sodium	Total	µg/L	NA	NA	NA
	Dissolved	µg/L	NA	NA	NA
Thallium	Total	µg/L	NA	2	2
	Dissolved	µg/L	NA	NA	NA
Tin	Total	µg/L	NA	NA	NA
	Dissolved	µg/L	NA	NA	NA
Vanadium	Total	µg/L	NA	NA	NA
	Dissolved	µg/L	NA	NA	NA
Zinc	Total	µg/L	37 - 387	NA	37 - 387
	Dissolved	µg/L	36 - 382	NA	36 - 382

**Table 18.4.7 Project Risks and PLP Planning and Management**

Risk	Pebble Planning Management
<b>Water:</b> Reductions in the quantity of surface and groundwater	Extensive baseline meteorological and hydrological (surface and groundwater) data collection.
	Integrated surface and groundwater flow modelling using numerous stations in project area streams.
	Preliminary determination of stream flow reductions in project area streams for different mine development concepts.
<b>Water:</b> Reductions in the quality of surface and groundwater	Extensive baseline water quality data collection.
	Extensive geochemical characterization of mine rock and tailings.
	Preliminary water chemistry prediction modelling to inform project design. Detailed prediction modelling is being undertaken in PFS stage.
<b>Aquatic Habitats:</b> Reductions in the capacity of deposit area streams to provide fish habitat, especially for salmon and trout	Alternatives analyses to avoid or minimize project footprint in sensitive habitat areas
	Sophisticated, preliminary habitat modelling for project area streams, based on anticipated flow reductions for different mine development concepts, to inform project design and needs for mitigation flow releases and additional mitigation/compensation measures.
	Development of flow release design criteria for the 2011 PFS program.
<b>Wetlands:</b> Filling in of wetlands requiring regulatory compensation	Comprehensive wetlands mapping of deposit area and access corridor.
	Access road aligned to avoid wetlands where possible and minimize stream crossings.
	Development of wetlands compensation options.
<b>Air Quality:</b> Air emissions permitting	Air quality data collection.
	Preliminary modelling of dust dispersion along access road.
	Preliminary estimate of power plant emissions to indicate permitting requirements.

Table continues...



...Table 18.4.7 (cont'd)

Risk	Pebble Planning Management
<b>Marine Environment:</b> Effects of construction and operations on protected species	Comprehensive baseline data collection of marine mammal and fish presence and habitat use.
	Minimize foreshore fill.
	Analysis of probable timing restrictions on construction activities to inform construction planning.

As an integral component of its corporate decision-making, the Pebble Partnership is planning to prepare a thorough Environmental and Social Impact Assessment (ESIA) in 2011. This ESIA is not required of mine developers under US or Alaskan law or regulations. It is being planned because of partner commitments to responsible mineral development and to inform a decision to move forward to feasibility studies. The ESIA will be led by senior ESIA practitioners with broad, worldwide experience in impact assessment, and will draw upon the independent baseline study consultants for impact analyses and the development of any required mitigation measures.

**18.4.6 CONCEPTUAL MINE RECLAMATION AND CLOSURE PLAN**

The primary objective of reclamation and closure activities at a mine site is to maintain the physical, chemical and biological stability of the site in perpetuity. Desired end land uses are also a factor, and are typically agreed upon with local communities and regulators. In Alaska, the general requirement is to return a project site to beneficial public use. For the Pebble Project, productive fish and wildlife habitats and subsistence uses are expected to be local priorities. This section describes the general activities that will be undertaken at the time the Pebble mine is closed. More detail will be developed during future project planning, public consultations and permitting.

**TAILINGS STORAGE FACILITY**

The tailings facility will contain both non-pyritic and pyritic tailings produced separately in the process plant. Pyritic or potentially acid-generating (PAG) tailings will be pumped in a separate pipeline from the plant to the TSF and deposited subaqueously, where they will be encapsulated by water and non-pyritic tailings to prevent oxidation. Pyritic tailings will not be placed on the tailings beaches. Non-pyritic tailings (about 85% of the tailings produced) are benign, and will be used to create beaches around the tailings pond. The beaches will be designed to be geotechnically stable to action by water and ice.

Once tailings deposition is complete, non-potentially acid generating (NAG) waste rock will be placed on the exposed tailings beaches to a depth of one meter. Growth medium will be placed on top of the rock and vegetated to a community suitable for that particular location. Similarly, the crest and face of the tailings embankments will be covered with growth medium and vegetated.

Tailings and reclaim water pipelines will remain in place and be used for post-closure water management. Surplus water from the tailings facility will be routed to the open pit via existing pipelines. When the pipelines are no longer needed, they will be dismantled and disposed of.

A water treatment plant will be installed near the mill building during operations. The plant will be used to treat water before being discharged to the receiving environment for as long as required.

## OPEN PIT

Surficial material in the open pit area will be salvaged, segregated and stored prior to mining. Material that is suitable for plant growth will be kept separate from material suitable for construction activities, and will be stored in designated areas to prevent degradation as a result of construction and mining activities. Stripping of the surficial material will be ongoing as the open pit's perimeter widens until the ultimate pit size is achieved.

During mine operations, PAG waste rock will be placed mainly in piles around the perimeter of the pit; some may be placed in a mined-out section of the open pit. Most of the open pit will be empty at the time mining concludes. At closure, the PAG waste rock will be processed through the mill to extract metal content and sulphides. The tailings from this process will be pumped to the open pit.

Following closure, the open pit will be permitted to fill with groundwater. The level of the pit lake will be maintained at an elevation that ensures the pit remains a groundwater sink. Surrounding groundwater will flow towards the open pit, and water levels will be maintained by pumping pit water to the water treatment plant. Flooding of the open pit at closure could be accelerated by pumping supernatant from the tailings storage facility and/or from another source.

To prevent inadvertent entry of people and wildlife into the open pit, an earthen berm will be built around the perimeter and the top of haul ramps.

## MILL SITE AND OTHER SURFACE FACILITIES

At closure, buildings and other structures that are no longer required will be dismantled. Recyclable material (e.g. steel, rubber, oil), un-used chemicals and all hazardous materials/wastes (e.g. milling reagents, grease) will be transported off-site and suitably disposed of. Non-recyclable and inert industrial materials (e.g. wood concrete) will be placed in an on-site engineered landfill.

On-site power generation will be scaled back to meet long-term site power requirements (e.g. water treatment plant). Unneeded power lines will be removed.

If buildings or foundations are contaminated with hydrocarbons or concentrate, this material will be excavated and either transported off-site or treated on-site in an approved facility.

Camp facilities will be scaled back to fit the needs for the operation of the water treatment plant and ongoing environmental monitoring.

All disturbed areas will be re-contoured to fit into the natural landscape. Growth medium will be placed on disturbed areas and vegetated to prevent soil erosion and encourage the development of a suitable plant community.

## ACCESS ROAD AND PORT

The access road will be kept open to access the site for ongoing care, maintenance and environmental monitoring. The buried concentrate, return water, diesel and gas pipelines will be flushed and left in place; associated surface facilities will be dismantled and removed. All disturbed land will be re-contoured and vegetated.

## WASTE ROCK STORAGE

During operations, waste rock from the open pit will be characterized, separated according to acid generation potential (see Section 18.2) and stored in distinct and separate areas. The storage areas will be constructed to a geometry that facilitates closure. The footprint of the storage areas is expected to be within the groundwater drawdown zone so that most water drains into the open pit; this will be studied further during future planning. Any seepage water that does not flow directly into the open pit will be collected in ponds and pumped to the pit.

At closure, PAG waste rock will be processed through the mill and the tailings deposited in the open pit. Once the PAG rock has been moved, the exposed base will be excavated and disposed of in the pit, and the base area will be covered with growth medium and vegetated. The level portions of the NAG rock dump will be covered with growth medium and vegetated.

## UNDERGROUND WORKINGS

Underground mine infrastructure (e.g. head frames, consumables, equipment, fuel) will be removed and recycled or disposed of according to regulations. Shafts will have engineered caps to prevent access. The underground workings will be allowed to flood and will eventually connect to the water in the open pit. Some of the NAG waste rock will have been placed over the subsidence zone during operations; this area will be covered with growth medium and vegetated prior to the time at which subsidence begins. An earthen berm will be placed around the subsidence zone to restrict entry.

### 18.4.7 SOCIOPOLITICAL ENVIRONMENT

The Bristol Bay region of southwest Alaska presents a multifaceted and geographically variable stakeholder landscape – including governments, Alaska Native tribes, corporations and institutions, communities, landowners and special interests. A summary of relevant groups and individuals is provided below.

#### GOVERNMENT OF ALASKA

Headquartered in the State Capital of Juneau, the Government of the State of Alaska is composed of an Executive and a Legislative Branch.

The Executive Branch is responsible for implementing and administering the public policy enacted and funded by the Legislative Branch. It is headed by a Governor and Lieutenant Governor, both of whom serve coincident four-year terms.

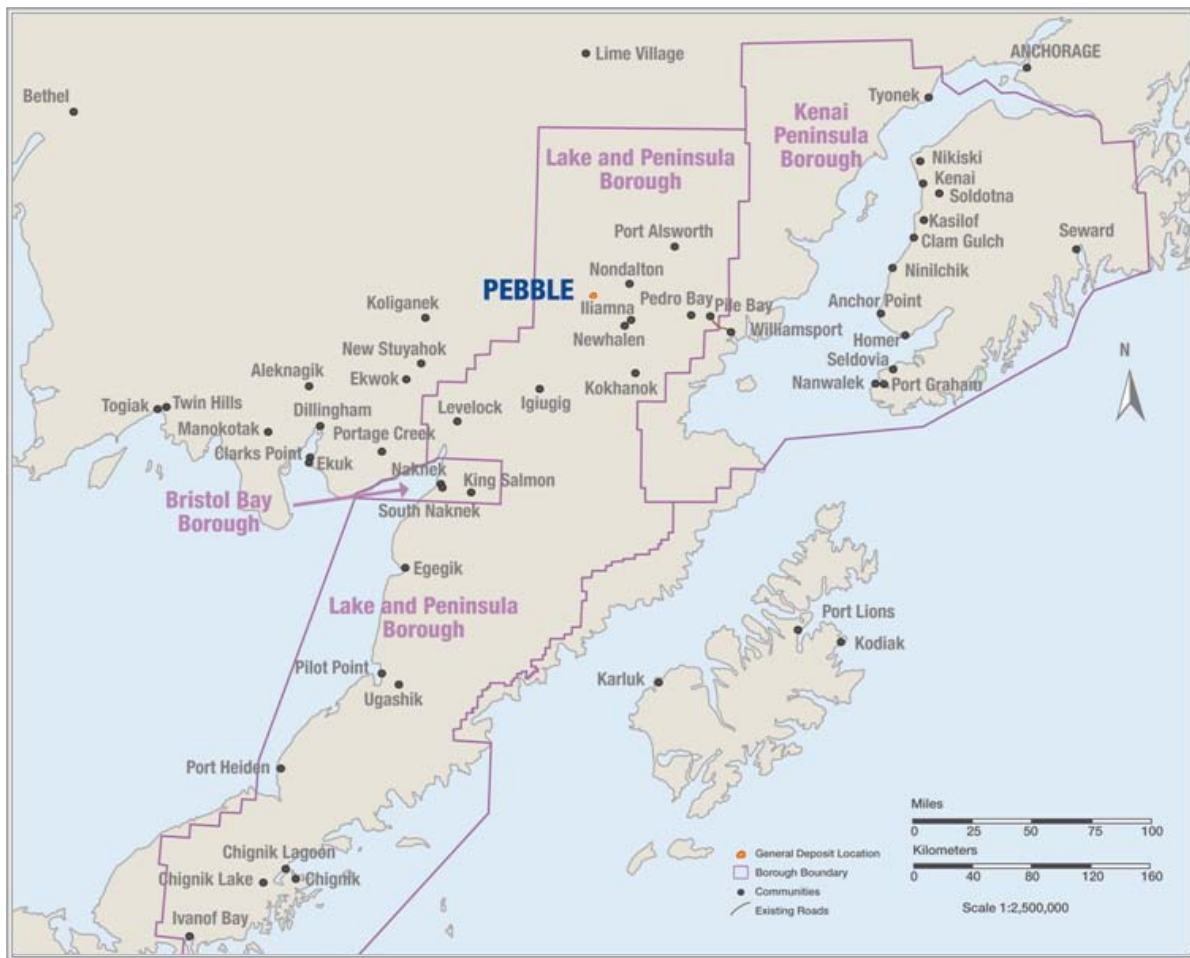
The Legislative Branch is responsible for enacting the laws of the State of Alaska and appropriating the money necessary to operate the government. It is composed of two bodies – the Senate and House of Representatives. The Senate has 20 members elected from 20 districts for four year terms, with one half of the membership standing for election every two years. The House of Representatives has 40 members elected from 40 districts for two year terms.

**BOROUGHS**

In Alaska, regional governments are called ‘boroughs.’ Boroughs serve a similar role that counties play in other US states, although only a portion of the State’s land base is included within Alaska’s 16 organized boroughs. Boroughs have local taxing authority and provide a range of services, including area-wide planning, land use regulation, public education and infrastructure development.

The Pebble Project is located within the 23,782 mi<sup>2</sup> (61,595 km<sup>2</sup>) Lake and Peninsula Borough (Figure 18.4.22). An estimated 1,485 people reside in 17 communities within the sparsely populated borough (US Census Borough, 2009 Population Estimate).

**Figure 18.4.22 Boroughs and Settlements of Southwest Alaska**



The 505 mi<sup>2</sup> (1,308 km<sup>2</sup>) Bristol Bay Borough is the only other organized borough in the Bristol Bay region of southwest Alaska. An estimated 881 people reside within this borough’s three communities (US Census Borough, 2009 Population Estimate).

A significant portion of the Bristol Bay region of southwest Alaska is not contained within an organized borough. The Dillingham Census Area comprises 11 different communities.

The 15,700 mi<sup>2</sup> (40,633 km<sup>2</sup>) Kenai Peninsula Borough spans both the east and west sides of Cook Inlet, including areas proposed for Pebble Project transportation and power infrastructure development. Approximately 99% of the borough's 54,665 residents live on the east side of Cook Inlet (US Census Borough, 2009 *Population Estimate*).

## CITIES

Some communities in the Bristol Bay region have organized as municipal or city governments. A city government is a municipal corporation and political subdivision of the State of Alaska. It generally exercises its powers within an established boundary that normally encompasses a single community. Under the state's constitution, a city is also part of the borough in which it is located.

Bristol Bay communities that are organized as cities, with elected city councils and municipal services, include Aleknagik, Chignik, Clark's Point, Dillingham, Egegik, Ekwok, Manokotak, New Stuyahok, Newhalen, Nondalton, Pilot Point, Port Heiden and Togiak (Figure 18.4.22).

## COMMUNITIES

The Bristol Bay region of southwest Alaska in which the Pebble Project is located is a vast area of nearly 40,000 square miles. In total, there are 29 predominantly Native villages or population centers, and roughly 7,000 full-time residents. They include Aleknagik (pop. 229), Chignik (62), Chignik Lagoon (73), Chignik Lake (105), Clark's Point (61), Dillingham (2,264), Egegik (73), Ekwok (109), Igiugig (64), Iliamna (91), King Salmon (383), Kokhanok (184), Koliganek (182), Levelock (88), Manokotak (438), Naknek (516), New Stuyahok (519), Newhalen (162), Nondalton (186), Pedro Bay (48), Perryville (122), Pilot Point (66), Port Alsworth (118), Port Heiden (83), Portage Creek (7), South Naknek (68), Togiak (820), Twin Hills (74) and Ugashik (15). (Alaska Department of Commerce, *Alaska Community Database Community Information Summaries*).

## TRIBES

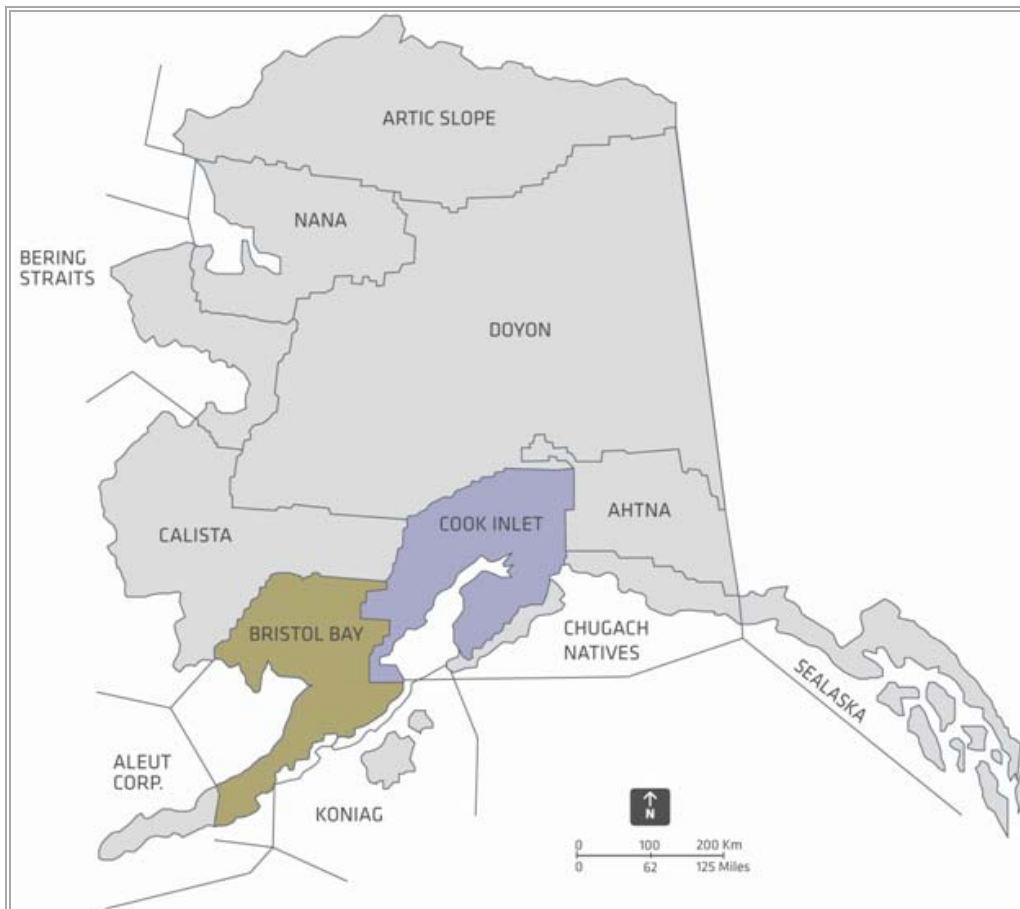
There are 31 tribal entities within the Bristol Bay region of southwest Alaska, as recognized by the U.S. Bureau of Indian Affairs. Each is represented by a tribal government, alternately known as a tribal council, traditional council or village council. Tribal governments range from informal arrangements whose structure and authority derive from centuries of cultural practice to formalized structures established in written constitution and bylaws.

Recognized tribal governments in the Bristol Bay region of southwest Alaska include: Aleknagik Traditional council, Chignik Bay Village Council, Chignik Lagoon Village, Chignik Lake Village Council, Clark's Point Village Council, Curyung Tribal Council (Dillingham), Egegik Village Council, Ekuk Village Council, Ekwok Village Council, Igiugig Village council, Iliamna Village Council, Ivanof Bay Village Council, King Salmon Village council, Kokhanok Village Council, Levelock Village Council, Manokotak Village Council, Naknek Village Council, Native Village of Perryville, New Koliganek Village (Koliganek), New Stuyahok Village Council, Newhalen Tribal Council, Nondalton Tribal Council, Pedro Bay Village Council, Pilot Point Village Council, Port Heiden Village Council, Portage Creek Village Council, South Naknek Village council, Tanalian Village Council (Port Alsworth), Togiak Traditional Council, Twin Hills Village Council and Ugashik Traditional Council.

### ALASKA NATIVE REGIONAL CORPORATIONS

The Alaska Native Claims Settlement Act (ANCSA) of 1971 established 12 ‘for-profit’ Alaska Native Regional Corporations (Figure 18.4.23) and granted the corporations financial resources as well as subsurface rights to 44 million acres of land (or roughly one-ninth of the State’s land base). A thirteenth Alaska Native Regional Corporation was established to represent Alaska Natives residing outside the State. Surface rights to those lands for which Alaska Native Regional Corporations hold subsurface rights are held by Alaska Native Village Corporations.

**Figure 18.4.23 Alaska Native Regional Corporations**



At the time ANCSA was enacted, some 80,000 individuals qualified as Alaska Natives. About two-thirds of these individuals received 100 shares in an Alaska Native Regional Corporation and 100 shares in an Alaska Native Village Corporation, while the other one-third were considered ‘at-large’ shareholders and received 100 shares in a Regional Corporation only.

Alaska Native Regional Corporations are charged with managing land and resources within their control in the best interests of their shareholders, and are required by law to share revenues generated through resource development with other Alaska Native Regional Corporations. Since 1971, Alaska Native Regional Corporations have grown into large, sophisticated and successful business enterprises that represent some of the state’s most significant business interests.

The Bristol Bay Native Corporation (BBNC) holds subsurface rights to some 3 million acres of land within the Bristol Bay region of southwest Alaska (Figure 18.4.25). There are some 8,600 BBNC shareholders living in the region, in other parts of Alaska and in the Lower 48 states. BBNC manages a sizable investment portfolio and owns subsidiary companies active in a range of business sectors, including cardlock fuelling, corporate services, corrosion inspection, environmental engineering and remediation, oilfield and environmental remediation, and government services. BBNC revenues in the fiscal year ending March 31, 2010 totalled nearly \$1.4 billion (Bristol Bay Native Corporation, 2010 *Annual Report*)

Another Alaska Native Regional Corporation, Cook Inlet Region, Inc. (CIRI), owns subsurface rights to 1.3 million acres of land on the east and west side of Cook Inlet, including areas proposed for Pebble Project transportation and power infrastructure development (Figure 18.4.25). There are some 7,300 CIRI shareholders living in the region, in other parts of Alaska and in the Lower 48 states. CIRI manages a sizable investment portfolio and owns subsidiary companies active in a range of business sectors, including energy and resource development, oilfield and construction services, real estate development, environmental remediation, tourism, telecommunications and aerospace. CIRI revenues in 2009 totalled nearly \$80 million (Cook Inlet Region, Inc., *CIRI Company Overview*).

**ALASKA NATIVE VILLAGE CORPORATIONS**

In addition to Alaska Native Regional Corporations, the Alaska Native Claims Settlement Act (ANCSA) of 1971 also led to the creation of more than 200 Alaska Native Village Corporations. These corporations were granted surface rights to the lands selected by Alaska Native Regional Corporations, and charged with managing these lands and resources in the best interests of Native shareholders living in their villages.

There are a total of 24 Alaska Native Village Corporations in the Bristol Bay region of southwest Alaska (Table 18.4.8).

**Table 18.4.8 Bristol Bay ANCSA Village Corporations and Villages Represented**

ANCSA Village Corporation	Villages Represented
Alaska Peninsula Corporation	Kokhanok, Newhalen, Port Heiden, South Naknek, Ugashik
Aleknagik Natives Ltd.	Aleknagik
Bay View, Inc.	Ivanof Bay
Becharof Corporation	Egegik
Chignik Lagoon Native	Chignik Lagoon
Chignik River Ltd.	Chignik Lake
Choggiung Ltd.	Dillingham, Ekuk
Ekwok Natives Ltd.	Ekwok
Far West Inc.	Chignik
Igiugig Native Ltd.	Igiugig
Iliamna Native Ltd.	Iliamna
Kijik Corporation	Nondalton
Koliganek Natives Ltd.	Koliganek
Levelock Natives Ltd.	Levelock
Manokotak Natives Ltd.	Manokotak

*Table continues...*

...Table 18.4.8 (cont'd)

ANCSA Village Corporation	Villages Represented
Oceanside Corporation	Perryville
Paug-Vik Ltd.	King Salmon, Naknek
Pedro Bay Village	Pedro Bay
Pilot Point Native Corporation	Pilot Point
Saguyak Inc.	Clark's Point
Stuyahok Natives Ltd.	New Stuyahok
Tanalian Inc.	Port Alsworth
Togiak Natives Ltd.	Togiak
Twin Hills Native Corporation	Twin Hills

Figure 18.24 Alaska Native Village Corporation Lands in Southwest Alaska

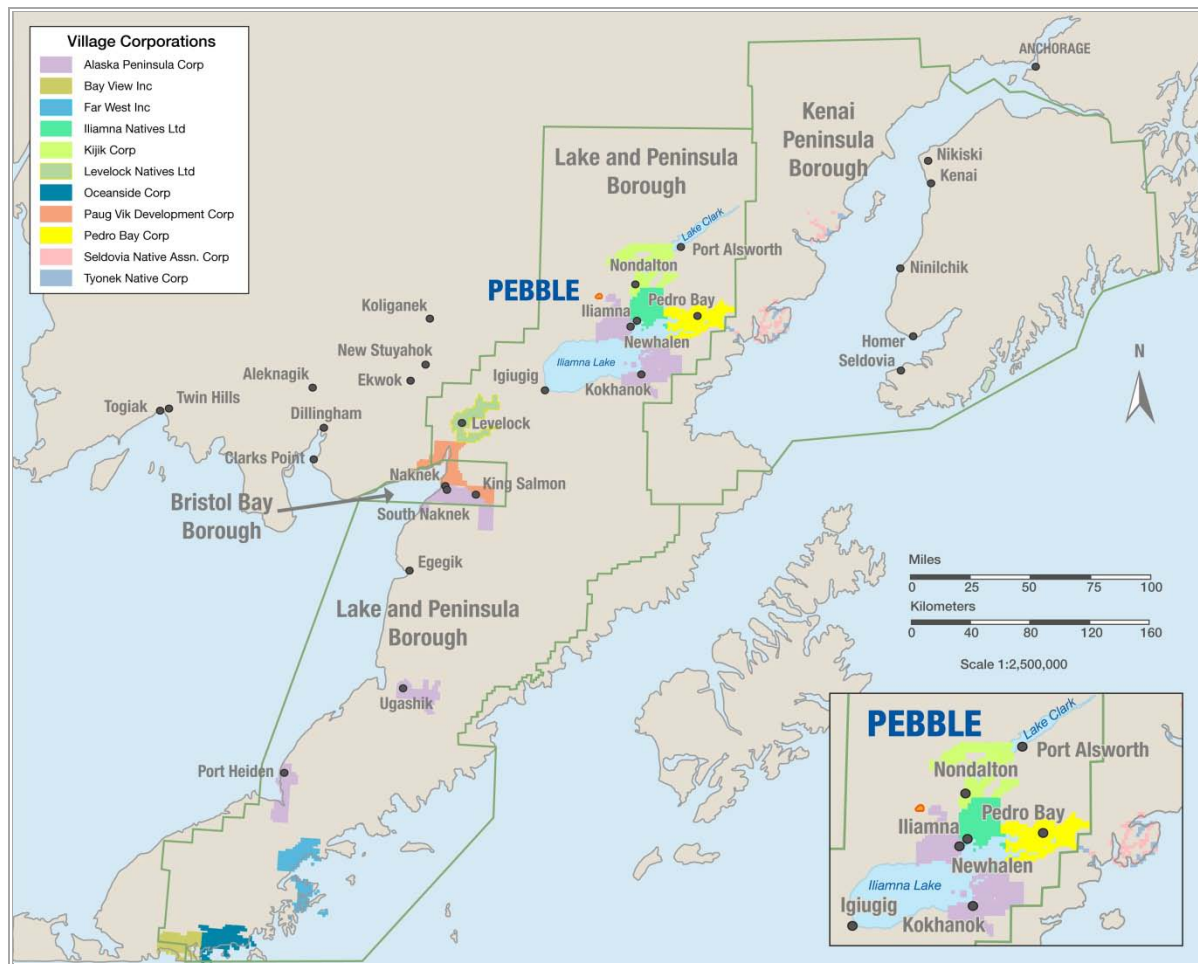
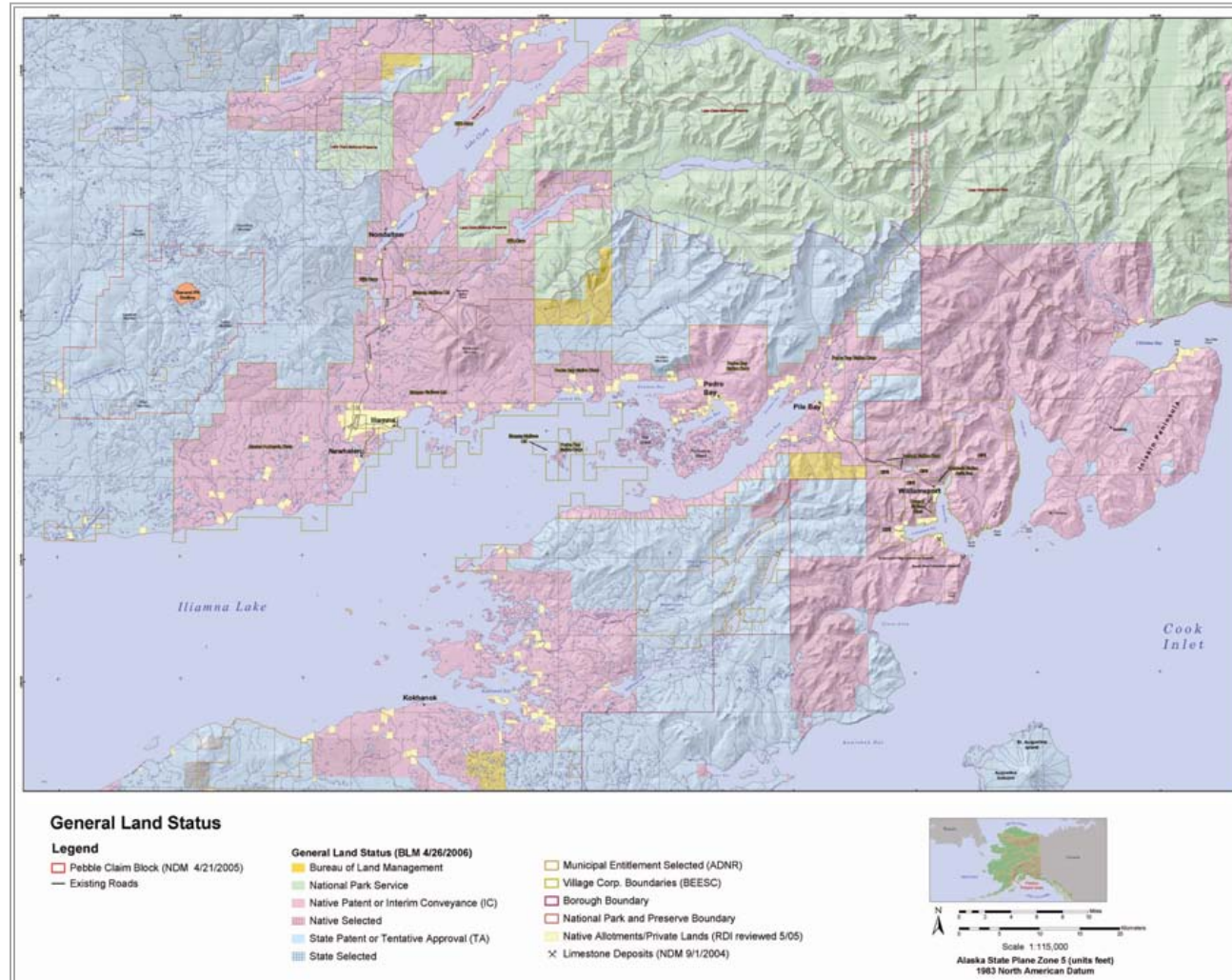




Figure 18.4.25 Alaska Native Village Corporation Lands in the Pebble Project Area



## OTHER REGIONAL INSTITUTIONS

There are a number of regional non-profit institutions in the Bristol Bay region of southwest Alaska that provide services to or act on behalf of local communities and residents. These include:

- Bristol Bay Native Association – a consortium of 31 tribes organized as a non-profit corporation to provide a variety of educational, social, economic and related services to the Native people of Bristol Bay;
- Bristol Bay Area Health Corporation – a non-profit regional service organization that provides health services to 34 tribes throughout the Bristol Bay region;
- Bristol Bay Economic Development Corporation – a non-profit organization based in Dillingham, whose mandate is to promote economic growth and opportunities for residents of Bristol Bay coastal communities through sustainable use of Bering Sea resources;
- Bristol Bay Housing Authority – a regional non-profit organization whose mandate is to facilitate quality, affordable housing for the Alaska Native population of the Bristol Bay region; and
- Southwest Alaska Municipal Conference – a regional non-profit economic development organization that serves all of southwest Alaska, including areas outside Bristol Bay.

## NATIVE ALLOTMENTS

Alaska Natives were given the right to apply for privately-held Native allotments in 1906. Individuals born prior to the enactment of the Alaska Native Claims Settlement Act (ANCSA) of 1971 could apply to the federal government for transfer of title to an allotment of up to 160 acres that they or their family have traditionally used for a range of purposes. While this right is more limited today, there are hundreds of Native allotments throughout the Bristol Bay region of southwest Alaska.

## ECONOMY AND SOCIAL CONDITIONS

The Alaska economy is heavily dependent on natural resources for both employment and government revenue. Oil and gas, mining, transportation, fishing and seafood processing, as well as tourism, represent a significant proportion of the overall private sector economy, with oil and gas contributing nearly 90% of state government revenues on an annual basis. At \$42,603 in 2009, per capita personal income in Alaska is above the national average of \$39,138 (US Department of Commerce, *Survey of Current Business*), and unemployment is generally below the national average (US Department of Labor, Bureau of Labor Statistics, *Regional and State Employment and Unemployment, December 2010*).

Of the nearly 700,000 people living in Alaska on a full-time basis, some 300,000 live in the greater Anchorage area, with more than half the state's population living in urban settings. Approximately 15% of Alaska's population is Native (US Census Bureau, *State and County QuickFacts*).

Public policy priorities in the State of Alaska include the development of a natural gas pipeline from the North Slope to the Lower 48 states to offset the economic impact of a significant and ongoing decline in North Slope oil production. Energy and economic development issues are public policy priorities in-state, as well – in particular, the need to provide long-term natural gas supply to

Anchorage and south-central Alaska, and the need to provide more competitively priced power to rural communities.

At 40,000 square miles (104,000 km<sup>2</sup>), the Bristol Bay region of southwest Alaska is vast and sparsely populated, with less than one person for each five square miles of land area. Population density in the Lake and Peninsula Borough is even lower, with one person per 18 mi<sup>2</sup>, making it the most sparsely settled county, parish or borough in the United States.

The Bristol Bay region's roughly 7,000 inhabitants reside in 29 villages, with just one (Dillingham) exceeding 1,000 residents. The average Bristol Bay community is home to about 150 people. Some 72% of the region's full-time residents are Alaska Native, descending from three major language groups: Yup'ik Eskimos, Aleuts and Athabaskans (US Census Bureau, *State and County QuickFacts*).

The private sector economy of the Bristol Bay region is dominated by commercial salmon fishing. Although the resource upon which the industry is based remains healthy, the economics of the fishery have declined significantly over the past several decades due to the rise of global salmon aquaculture and various domestic policy and market factors. Ex-vessel prices for sockeye salmon, the dominant species in the Bristol Bay fishery, have fallen from an inflation-adjusted peak of \$3.75/lb in 1988 to a 10-year average of just under \$1.00/lb in the 1990s and \$0.60/lb in the 2000s (Knapp et al., 2007; Morstad et al., 2010). The ex-vessel value of the Bristol Bay commercial salmon fishery in 2010 is estimated at \$153 million (Alaska Department of Fish & Game, *2010 Bristol Bay Salmon Season Summary*).

As a result of these declines, the percentage of Bristol Bay fishing licenses and related employment held by residents of the region has fallen significantly over the past 20 years. Bristol Bay's economy today is characterized by a high proportion of non-resident labour and business ownership. Key private-sector industries are highly seasonal, such that unemployment among year-round residents is particularly high. Just 12.8% of private sector workers in the Lake and Peninsula Borough are local residents, while local residents hold 8% and 46.3% of private sector jobs in the Bristol Bay Borough and Dillingham Census Area respectively (Alaska Department of Labor, *Non-residents Working in Alaska 2009*).

The average cost of living in Bristol Bay communities is high, due to the requirement to fly in many of the goods and commodities required for daily life, including fuel for heating homes and operating vehicles. Energy costs, in particular, are a significant deterrent to economic development.

As a result of a lack of jobs and economic opportunity in the region, Bristol Bay communities are slowly losing population as residents seek opportunities in other parts of the State. The population of the Lake and Peninsula Borough has declined 16% since 1997 (Alaska Department of Labor and Workforce Development), while its school enrolment has declined 36% over the same timeframe (Alaska Department of Education and Early Development). In several communities, schools have closed or are threatened with closure as a result of diminishing enrolment. The public school in the village of Pedro Bay closed its doors in 2010.

A subsistence lifestyle is practiced by the vast majority of residents of Bristol Bay communities, including fishing for salmon and other species, hunting of terrestrial mammals and birds, and gathering berries. Salmon, in particular, are considered a critically important resource for the region, from a cultural, economic and social perspective.

#### 18.4.8 STAKEHOLDER AND COMMUNITY RELATIONS

The Bristol Bay region of southwest Alaska presents a multifaceted and geographically variable stakeholder environment (Section 18.6.7). There are dozens of communities and institutions scattered throughout a large and isolated region with few surface transportation links. Many of these stakeholder groups have specific preferences and requirements for the manner in which they are consulted.

Since 2004, the Pebble Partnership and its predecessor Northern Dynasty have implemented a comprehensive stakeholder relations and community outreach program. In addition to ensuring that relevant stakeholder groups and individuals receive early notification of all work programs, the objectives of the Pebble Partnership's stakeholder and community relations program are:

- to provide regular progress updates on project-related activities, opportunities and planning;
- to seek input on stakeholder priorities, issues and concerns, and provide feedback on how they are being addressed;
- to educate stakeholders on responsible resource development and modern mining principles and practices;
- to maximize economic and community benefits associated with the Pebble Project, both in the exploration and development phase and during mine operations; and
- to provide opportunities for two-way dialogue and the development of long-term, respectful and mutually beneficial relationships.

The Pebble Partnership has developed a dedicated and knowledgeable stakeholder relations team to implement this program. In addition to a senior Stakeholder Relations Manager and staff in Anchorage, the team includes a number of representatives living in Bristol Bay communities. The company has provided ongoing training for all of its community relations personnel.

#### STAKEHOLDER ENGAGEMENT AND CONSULTATION

The Pebble Project focuses its stakeholder relations and community outreach activities in four key areas:

- communities, institutions and interests in the Lake Iliamna/Lake Clark region;
- communities, institutions and interests in the broader Bristol Bay region;
- communities, institutions and interests on the Kenai Peninsula; and
- state-wide communities, institutions and interest groups, including business organizations, recreation and outdoor interests, among others.

Since 2004, Northern Dynasty and subsequently the Pebble Partnership's stakeholder relations team and corporate staff have undertaken more than 4,000 formal and informal meetings with stakeholder groups and individuals. These include: community meetings and open houses sponsored by the company in each of the 29 Bristol Bay communities; forums held for regional and community leaders in Anchorage and other central locations; participation at conferences, seminars, hearings, meetings

and events sponsored by external groups; and, private meetings arranged with specific groups and individuals. All such meetings are recorded and stakeholder input is documented. In certain cases, translation services are utilized to ensure Native elders can participate in stakeholder consultation exercises.

The Pebble Partnership also engages local, regional and state-wide stakeholders via a dedicated project website, outgoing digital and hard-copy newsletters, other printed materials and mailers, and print, radio and television advertising. The company manages an ongoing speakers' bureau to provide presentations and project updates to stakeholder and special interest groups throughout the state.

As noted, Bristol Bay is a vast and sparsely populated region that supports significant fisheries, wildlife populations and largely Native communities that practice a traditional subsistence way of life. As such, over the course of its stakeholder engagement program, the principal concerns PLP has heard from local, regional and state-wide interests concerning development of the Pebble Project include:

- potential effects on water quality, aquatic habitat and fish productivity;
- potential effects on commercial, subsistence and sport fisheries;
- potential effects on terrestrial wildlife and other subsistence resources; and
- potential effects on communities and traditional ways of life associated with an influx of mine workers.

The principal opportunities that stakeholders suggest the Pebble Project presents for local and regional interests include:

- training and the provision of year-round, well-paid and stable employment in rural Alaska;
- business and contracting opportunities associated with mine procurement and the spending of employee wages;
- the development of new community services and infrastructure associated with local taxation;
- the potential for the development of new regional transportation and power infrastructure to benefit communities; and
- the potential for new employment, business development, taxation and related activity to improve overall economic conditions and quality of life.

In order to broaden opportunities for stakeholder involvement in the Pebble Project, the Pebble Partnership is working with the Keystone Center – a Colorado-based, not-for-profit organization that specializes in developing and facilitating independent stakeholder dialogue processes. In December 2010, the Keystone process for the Pebble Project began a series of Independent Science Panel (ISP) events to provide expert, third-party review of the Pebble Partnership's environmental baseline study program. This process is one expression of the Pebble Partnership's corporate commitment to independent review of the science underpinning the design of the Pebble Project.

The Keystone Center has recruited an expert Science Advisory Committee to help plan and facilitate these ISP events, including the recruitment of expert panelists from a range of technical and scientific disciplines. ISP events to be undertaken over the course 2010 and 2011 will address:

- Responsible Large-Scale Mining: Global Perspectives;
- Geology and Geochemistry;
- Hydrology and Hydrogeology;
- Fish, Wildlife and Habitat; and
- Socio-Cultural and Economic Dynamics.

## PUBLIC EDUCATION

As part of its mandate to enhance stakeholder understandings of responsible resource development and modern mining, the Pebble Partnership has designed a multi-faceted public education program that it has delivered since 2005. Elements of this program include stakeholder presentations, often involving industry and technical experts. A robust publishing and multi-media program also supports the Pebble Partnership's public education initiative, including on-line content, video production, brochures and backgrounders, as well as curriculum resources that address mining careers, training requirements and an overview of the mineral development process.

Over the past several years, the Pebble Partnership has also developed a comprehensive tour program to allow local, regional and state-wide stakeholders to experience mineral exploration and development activities up close, and to visit operating and reclaimed mine sites. Through 2010, some 350 tours have been executed to provide more than 2,000 Alaska stakeholders with first-hand experience of the mining industry, including 15 visits to operating mines in Alaska, other US states, Canada and Chile.

## COMMUNITY INVESTMENT

The Pebble Partnership and its predecessor Northern Dynasty have committed significant funding to provide opportunity and improve the quality of life in Bristol Bay communities. Community investments have included small grants to local charities, non-profits, schools, service organizations and other groups providing valuable services to local communities. They have also included larger investments (both financial and in-kind) to support significant community projects – such as the development of new water wells, geothermal exploration initiatives and the development of community incinerators and recycling programs.

In 2008, the Pebble Partnership established the *Pebble Fund* – a five year \$5 million endowment to enhance the health and sustainability of regional fisheries and the communities they support. Grants are awarded based on criteria and selections made by an independent advisory board of citizens from communities throughout the Bristol Bay region, and administered by the Alaska Community Foundation. As of the end of 2010, the *Pebble Fund* has supported 65 community-led projects throughout the Bristol Bay region of southwest Alaska, directly investing more than \$2.4 million while leveraging nearly \$12 million in matching funds from other organizations. Examples of funded projects include fisheries enhancement, alternative energy development, safe drinking water,; community greenhouses, and vocational training and internship programs.

## TRAINING AND WORKFORCE DEVELOPMENT

The Pebble Partnership and its predecessor Northern Dynasty have made an explicit commitment to maximize local employment at the Pebble Project, both at the exploration and development stage and during mine operations. The company is pursuing this goal by ensuring that local residents receive priority consideration for employment, based on qualifications and merit, and advancing ongoing workforce development, training and community outreach initiatives.

The Pebble Partnership employs a dedicated on-site 'Local Hire' coordinator to facilitate local recruitment. It also ensures that all of its on-site contractors and suppliers strictly observe its 'Local Hire' policy. Workforce development programs include training in the areas of equipment operations, health, safety and environment. The Pebble Partnership also provides for flexible work schedules, such that local employees can participate in traditional fishing, hunting and other subsistence activities.

Working with the US and Alaska Departments of Labor, the Pebble Partnership developed the first-ever registered apprenticeship training program to help local drill helpers become certified drillers. The company is also investing in programs to train local workers to become environmental technicians, emergency medical technicians and bear guards. In addition, scholarships are available to high school students from the Bristol Bay region that are interested in pursuing studies at university, college and vocational/technical schools in natural resource development fields (e.g. project management, operations, geology, science and engineering).

Further, the Pebble Partnership maintains funding and working relationships with a number of organizations that help deliver training for resource development careers in the State of Alaska, including the Alaska Native Science and Engineering Program (ANSEP), the Alaska Mineral and Energy Resource Education Fund (AMEREF), Southwest Alaska Vocational Education Center (SAVEC), among others.

As a result of its local training and workforce development initiatives, the Pebble Project has emerged over the past five years as one of the leading private sector employers in southwest Alaska. In 2009, a total of 106 people from communities throughout Bristol Bay were employed by the Pebble Project.

The Pebble Partnership is currently developing a long-term Workforce Development strategy to ensure that skills training, professional development and other programs are in place to maximize the number of Bristol Bay and Alaska residents that secure jobs at every level of employment in the lead-up to and during mine operations.

## BUSINESS DEVELOPMENT

Since 2005, the Pebble Partnership and its predecessor Northern Dynasty have advanced programs to enhance the capacity of local businesses to provide goods and services to the Pebble Project and to position themselves to benefit from mine operations in future. In particular, these programs have focused on Alaska Native Village Corporations in the Lake Iliamna/Lake Clark region.

Business Development programming began with the company providing funds to three Alaska Native Village Corporations to undertake 'economic visioning studies,' utilizing expert consultants to identify priority business goals related to the Pebble Project and other regional opportunities.

Since that time, the Pebble Partnership has developed commercial relationships with five Alaska Native Village Corporations: Iliamna Natives Limited/Iliamna Development Corporation; Pedro Bay Corporation; Alaska Peninsula Corporation; Kijik Corporation; and Igiugig Natives Ltd. Not only have these commercial relationships generated employment, training and revenue for participating Village Corporations, they have also allowed them to develop the human and financial resources necessary to capture additional business opportunities.

Current and past contracts that the Pebble Partnership has held with Alaska Native Village Corporations include lodge, vehicle and equipment rentals; catering, facilities management, payroll and administrative services; helicopter and heavy equipment leasing; the provision of environmental baseline data collection services; and transport of fuel and other supplies.

The Pebble Partnership is currently developing a comprehensive Business Development strategy to ensure that local businesses, including Alaska Native Village and Regional Corporations, are aware of long-term business and contracting opportunities and can position themselves to benefit from mine operations in future. This includes opportunities to outsource major components of Pebble Project transportation and power infrastructure to Alaska Native Corporations.

#### STAKEHOLDER AND PUBLIC POSITIONS

Although the Pebble Partnership has not yet finalized a Project Description or initiated federal and state permitting under NEPA, the Pebble Project has a very high profile in Alaska. This is largely due to the size and global importance of the known mineral resource, and its location in a region notable for its lack of industrial development and the significance of its fisheries.

US activist organizations have a long history of campaigning against natural resource development in the State of Alaska. A series of campaigns and initiatives have been undertaken in opposition to the Pebble Project since 2005, with the principal goal of halting the project before it enters the federal and state permitting process. Activists have sought to stop the Pebble Project via legal, legislative, electoral, market and media initiatives. To date, none of these initiatives has been successful.

Certain Native tribes and institutions in the Bristol Bay region have expressed opposition to the Pebble Project as well, principally due to concerns about the proposed mine's potential effects on water quality, fish and wildlife resources, and traditional ways of life. A non-profit organization called *Nunamta Aulukestai*, representing eight Alaska Native Village Corporations from western Bristol Bay communities (Ekwok, Koliganek, New Stuyahok, Clark's Point, Aleknagik, Togiak, Manokotak and Dillingham) is actively working in opposition to the Pebble Project (see [www.nunamta.org](http://www.nunamta.org)).

The Pebble Partnership has developed strong working relationships with local workers, communities and institutions in southwest Alaska, particularly those in the Lake Iliamna/Lake Clark area. As discussed previously, the Pebble Partnership has well-established commercial partnerships with five Alaska Native Village Corporations.

As well, a broad range of regional Native and non-Native institutions have passed resolutions that support the federal and state permitting process as the appropriate venue for determining the acceptability of the proposed Pebble mine, and the efforts of the Pebble Partnership to advance an environmentally sound and socially responsible project. The 17 Native institutions from the Bristol Bay

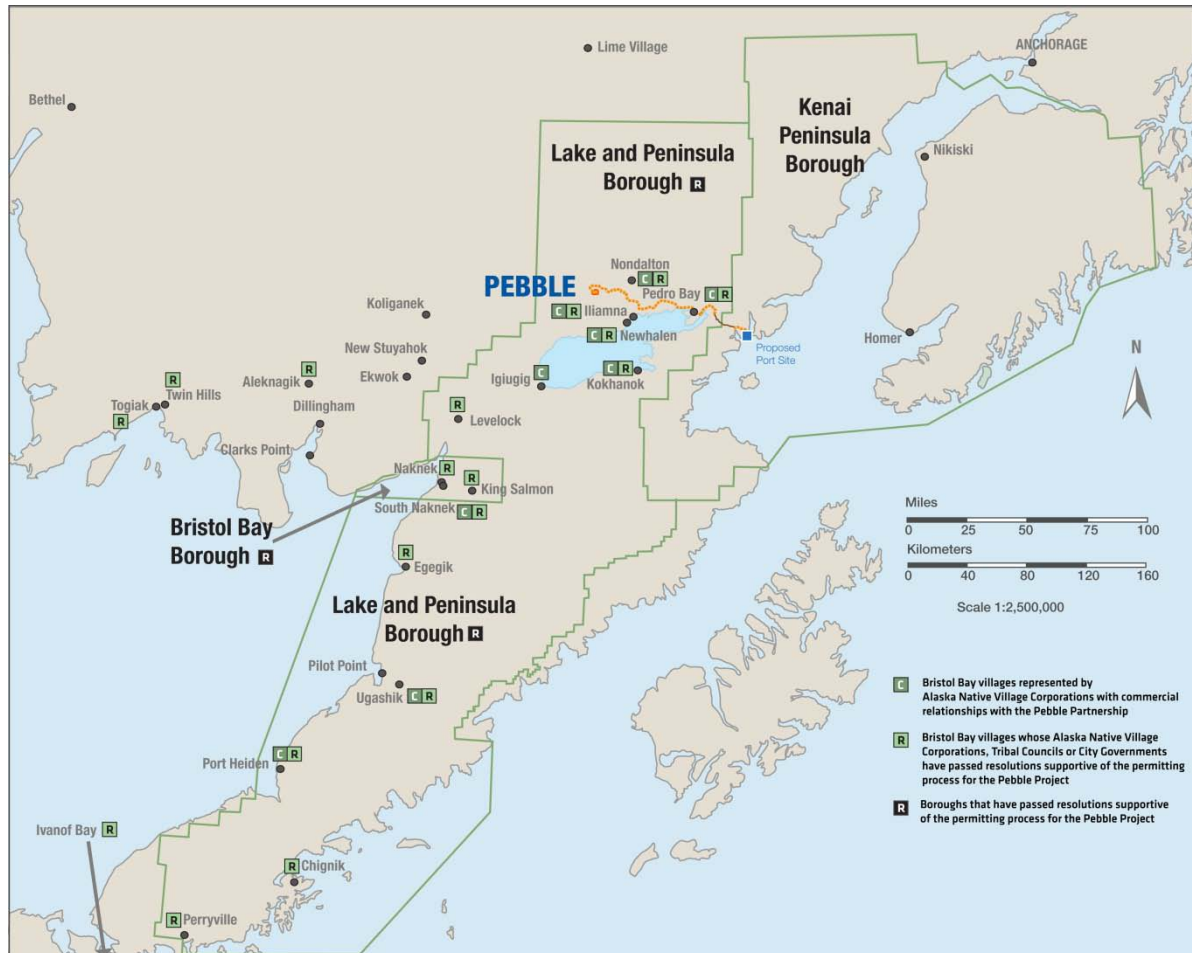


region that have passed such resolutions are: Alaska Peninsula Corporation; Aleknagik Traditional Council; Bay View Inc.; Far West, Inc.; Iliamna Natives Ltd.; Ivanof Bay Village Council; Kijik Corporation; King Salmon Tribe; Levelock Corporation; Naknek Native Village Council; Newhalen Tribal Council; Oceanside Corporation; Paug-Vik Ltd.; Pedro Bay Corporation; South Naknek Village Council; Togiak Tribal Council; and Twin Hills Native Corporation. Non-Native institutions in the region that have passed such resolutions include Lake and Peninsula Borough; Bristol Bay Borough; City of Egegik; and Southwest Alaska Municipal Conference. Other Native and non-Native groups and institutions from across the State of Alaska have also passed supportive resolutions (see <http://www.pebblepartnership.com/community/resolutions>).

Bristol Bay villages represented by Alaska Native Village Corporations that have commercial relationships with the Pebble Partnership, and those whose Alaska Native Village Corporations, tribal councils or city governments have passed resolutions supportive of the permitting process for Pebble, are identified in Figure 18.4.26.

A majority of public officials in the State of Alaska, including the Governor and legislators in the Senate and House of Representatives, have expressed support for the State's environmental regulations and permitting requirements for hardrock mining as sufficient to protect the public interest. So too has the Alaska public. In 2007, 79% of respondents to a public opinion survey undertaken by the Finance Committee of the Alaska Legislature expressed support for *“going forward with the environmental impact studies for the proposed Pebble mine to determine whether or not the mine could be developed in a responsible manner”*. In November 2008, a majority of Alaska voters defeated a ballot measure by a margin of 57% to 43% that would have instituted new water quality standards for hard rock mines.

Figure 18.4.26 Bristol Bay Community Institutions Supportive of Permitting Process



## 18.5 CAPITAL COST ESTIMATE

---

### 18.5.1 SUMMARY

This capital cost estimate has evolved over a series of project stages, with data updated to reflect the evolution of the design and updated pricing. Wardrop has conducted a high level review of the capital cost estimate that was provided to the Pebble Partnership by AMEC Americas Ltd. The costs are largely based on first principles estimates; quantities have been derived for project components, to which productivities and labour rates estimated for specific trades have been applied. The result is an estimate which approaches prefeasibility-level accuracy.

For this study, the initial capital cost has been developed in four distinct steps:

1. Estimate the total project initial capital costs in second quarter 2009 U.S. dollars;
2. Escalate or de-escalate to current dollars;
3. Remove from the estimate those costs to construct primary infrastructure components, including power generation, port facilities and access road, which will be provided by third parties; and
4. Include the cost of an off-shore molybdenum refinery.

The initial capital cost to design, construct, and commission all three development cases presented in this Preliminary Assessment is \$4,695 million.

Using the steps described above:

1. Preliminary estimate - \$5,757 million
2. Less de-escalation - \$121 million
3. Less outsourcing / partnerships - \$1,315 million
4. Molybdenum refinery addition - \$374 million.

This cost estimate is summarized by phase in Table 18.5.1.

This estimate includes:

- direct field costs for executing the project;
- indirect costs associated with the design, construction and commissioning of new facilities;
- owner's support costs for corporate, environmental, permitting and staffing
- capital costs to completion of construction and commissioning; and
- contingencies.

### 18.5.2 CURRENCY EXCHANGE AND OTHER RATES

Currency exchange rates used in this capital cost estimate are as follows:

- US\$1.00 = CAD\$1.02;
- US\$1.00 = Euro 0.685;
- US\$1.00 = AUD\$1.064;
- US\$1.00 = ZAR 7.70;
- US\$1.00 = Yen 104.95.

Diesel fuel prices, delivered to Seattle, used in this capital cost estimate are \$3.05 per gallon before the diesel fuel pipeline is operational, and \$2.76 per gallon after diesel fuel pipeline is operational.

**Table 18.5.1 Capital Cost Summary by Phase**

Area	Capital Cost (\$ M)
Mining	430.80
Process	1,058.2
Molybdenum Separation	83.5
Secondary Gold Plant	160.5
Infrastructure	422.0
Tailings	294.0
Pipelines	97.5
Access Road *	162.0
Port infrastructure *	154.5
Port process	87.1
Power generation *	534.1
Indirect costs	1,406.8
Contingency	865.7
<b>Total Capital Cost Estimate</b>	<b>5,756.7</b>
Molybdenum Autoclave	374.2
Less: Escalation/De-escalation Adjustments	(121.1)
Less: Outsourced Infrastructure *	(1,315.0)
<b>Initial Capital – Financial Model</b>	<b>4,694.8</b>

Note: (\*) These project components to be provided by third parties.

These costs, along with their associated indirect costs and contingencies, total \$1,315 million.

### 18.5.3 ESTIMATE RESPONSIBILITY

This capital cost estimate incorporates the work of Pebble Partnership and a number of consultants. The latter include AMEC, Knight Piésold, PND, Brass, RECON, Nana Worley Parsons and NCL.

18.5.4 WORK BREAKDOWN STRUCTURE AND DEFINITION SUMMARY

The capital cost estimate has been aligned with the work breakdown structure (WBS) to identify estimate line items, as shown in Table 18.5.2.

**Table 18.5.2 Work Breakdown Structure (WBS)**

Item	Phase	Sub-Phase	Facility	Sub-Facility	Job
WBS	XX	XY	AAAA	ABBB	JJJJ

WORK BREAKDOWN STRUCTURE BY PHASE

The WBS by phase (which is an identifier for functional area) is shown in Table 18.5.3.

**Table 18.5.3 WBS by Phase**

Phase	Sub-Phase	Description
10		Mining
	11	Open Pit Mining
	12	U/G Early Access
	13	U/G Production Development
20		Process Plant
	21	Bulk Process
	22	Molybdenum/Copper Process
	23	Gold Process
30	-	Infrastructure
40	-	Waste Management
50	-	Access Road/Concentrate Pipeline
60		Port
	61	Port Infrastructure
	62	Port Process
70	-	Power – On Site Generation
80	-	Indirects

The costs included in the phase items are described below.

*Mining*

- Phase 11: open pit pre-production mining; haul roads; mining equipment; support equipment; equipment erection; mine dewatering and mine electrical.

*Process*

- Phase 21, Bulk Process: general process items, including crushing, conveying, grinding, bulk flotation, construction equipment and the process building.

- Phase 22, Molybdenum/Copper Process: items related directly to the molybdenum/copper process, including flotation; concentration and reagents.
- Phase 23, Gold Process: items related directly to the gold gravity separation and secondary recovery processes Site Infrastructure
- Phase 30, Infrastructure: includes plant site preparation; site roads; water distribution; water treatment; waste treatment; fuel distribution; warehouses; shops; offices; laboratories; permanent camp; truck shop; mobile equipment; substation; power distribution; communication systems; bus shelters and security gatehouses.

#### *Waste Management*

- Phase 40, Waste Management: includes tailings management structures; tailings pipeline and reclaim system.

#### *Transportation Infrastructure*

- Phase 50, Access Road/Concentrate Pipeline: includes the access road and concentrate, water return, and diesel pipelines between Port Site 1 and the mine site.
- Phase 61, Port Infrastructure: includes port site preparation; port site roads; barge dock; ship loader; fuel storage; warehouse; shop; office; laboratory; permanent camp; mobile equipment and power generation and distribution.
- Phase 62, Port Process: includes copper concentrate filtration; filtration building and concentrate storage.

#### *Power Generation*

- Phase 70, Power Generation: includes the main power generation plant located at the mine site and the natural gas pipeline from the Kenai Peninsula to the mine site.

#### *Indirects*

- Phase 80, Indirects: includes Owner's costs; EPCM costs; construction camps; catering; construction indirect facilities and services; commissioning; spare parts; freight; logistics management and contingency.

#### **WORK BREAKDOWN STRUCTURE BY FACILITY**

The second level in the WBS defines the facility and is equivalent to the capital code structure. It identifies specific major steps in the process or utility work areas in the project. The WBS by major facility code is shown in Table 18.5.4.

Detailed items have been entered into the estimate at the most detailed sub-facility level.

**Table 18.5.4 WBS by Facility**

Facility	Description
1000	Mining Access
2000	Raw Materials – Handling and Storage
3000	Treatment Plant
4000	Treatment Plant (Continued)
5000	Utility Plant
6000	Civil Engineering Services
7000	Architectural Services (Building and Related Services)
8000	Mechanical and Electrical Services
9000	Financial

**WORK BREAKDOWN STRUCTURE BY JOB**

The job code is the capital coding number that provides a progressively more detailed breakdown of the work in terms of activities or commodities within each facility. The WBS by job is shown in Table 18.5.5.

**Table 18.5.5 WBS by Job Code**

Job	Description
1000	Mechanical Equipment
1100	Mining Equipment
1150	U/G Mining Equipment
1200	Mobile Equipment and Transportation
1210	Loading and Hauling Equipment
1220	Haulage and Scraping Equipment
1250	Road Vehicles
1300	Materials Handling (conveyors, feeders, pumps, cranes, and sampling)
1400	Chemical Processing Equipment (carbon screens, columns, and towers)
1500	Air and Heating/Refrigeration Equipment (compressors, blowers, fans, and dust extraction)
1600	Comminution, Sizing and Agglomeration (crushers, mills, screens, grizzlies, and scrubbers)
1700	Concentration and Separation (classifiers, concentrators, filtering, thickeners, clarifiers, cyclones, mixing, and magnets)
1800	Heat Transfer Equipment (heat exchangers, fired heaters, dryers, boilers, furnaces, kilns, and casting)
1900	Workshops, Stores and Laboratory Equipment (workshop, foundry, stores, laboratory, general, and yard)
2000	Instrumentation and Computers
2500	Communication Transmission and Receiving Equipment (telephone, radio, security, radar, and signaling)
2600	Instrumentation and Process Control Equipment
3000	Civil, Mining, and Concrete
3100	General Civil Engineering Work (clear site, piling, drainage, fencing, and surfacing)
3200	Earthwork and Mining Excavations (excavation, trenching, backfill, compaction, shoring, and mining excavations)
3300	Concrete in Foundations, Surface Beds and Substructures (foundations, lean concrete)

*Table continues...*

...Table 18.5.5 (cont'd)

Job	Description
3400	Superstructure (elevated) Concrete Stockpiles, Silos, and Bins
3500	Concrete Work Associated with U/G Mining
4000	Structural Materials (excluding concrete)
4100	Structural Steelwork (pre-engineered buildings)
4200	Plate work (ducting, chutes, hoppers, bins, tanks, and launders)
4300	Miscellaneous Fabricated Steel and Ironwork (flooring, ladder, stairs, and handrails)
5000	Electrical Systems and Hydraulic Systems
5100	Power Transmission and Distribution (o/h power lines, cables, busbar, substation equipment, and grounding)
5200	Switchgear and Control Gear (circuit breakers, switches, control panels, outlets, and plugs)
5300	Lighting and Electrical Space Heating
5400	Transformers, Rectifiers, Power Factor Correction
5500	Electric Motors and Generators, Battery Systems
5600	Hydraulic Systems
6000	Pipework and Valves
6100	Process Piping
6300	Civil Overland Piping
7000	Building Works (cladding, masonry, plumbing, furnishings, safety equipment, fire protection systems, pre-fabricated buildings)
8000	Protective Finishes and Linings
8100	Paintwork and Coatings
8200	Insulation and Fireproofing
8300	Refractory and Linings (including rubber lining and acid-proof bricks)
9000	Distributable and Indirect Costs

### 18.5.5 CONSTRUCTION SCHEDULE

The capital cost estimate is based on the project schedule, the major milestones of which are shown in Table 18.7.6.

**Table 18.5.6 Project Schedule Significant Milestones**

Milestone Description	Milestone Date
Board Approval	Project Start
Final Permits Issued for Construction	Month 3
Temporary Access to Site	Month 5
Permanent Access to Site	Month 9
Start Tailings Impoundment Facility	Month 20
Start Preproduction Stripping	Month 32
Complete Permanent Port Site 1 Dock	Month 38
Complete Tailing Impoundment for Start-up	Month 41
Permanent Power Available at Site	Month 42
Process Plant – Line 1 Complete	Month 48
Production Commences	Month 48



### 18.5.6 CONSTRUCTION LABOUR HOURS AND COSTS

Estimated on-site work hours have been used to develop construction catering costs and personnel logistics. The total estimated on-site labour requirements are 20 million hours.

#### LABOUR RATES

Labour rates have been calculated by adjusting Little Davis Bacon base labour rates published in September 2009 for Southern Alaska. Benefits and burdens assumed an open-shop contractor. The labour rates have been based on 12-hour days, working 21 days on with a 7-day unpaid rotation. In general, the labour rates have been built up into composite crew rates based on appropriate crew mixes that include:

- base labour wage rate;
- overtime premiums at 1.5 times base rate;
- benefits and burdens (including vacation, workers compensation premiums, FICA, EI, pension and medical insurance);
- MSHA safety training (not including site-specific);
- ten hours travel time per rotation;
- travel costs; appropriate crew mixes;
- small tools and consumables;
- contractor temporary facilities and services;
- contractor general support based on a 1:7 ratio of direct work hours ;
- contractor supervision/administration based on a 1:4 ratio of direct work hours; and
- contractors' overhead and profit.

The labour rates used for the various trade crews are shown in Table 18.5.7. Subsistence or camp and catering costs are allowed for in the project indirect costs and are not included in the labour rate.

#### INSTALLATION WORK HOURS

Labour productivity has been adjusted from standard rates to compensate for labour availability, skill level, climate conditions, work location, construction methods, and overtime. The labour productivity factors used in the estimate are shown in Table 18.5.8.

**Table 18.5.7 Contractor Labour Rates**

Area	(\$/h)
Civil General	116.20
Civil Piping	117.70
Civil Structural	106.20
Concrete	107.20
Structural Steel	116.30
Architectural	106.50
Building Services	122.40
Mechanical	122.40
Tanks and Vessels	116.20
Process Piping	117.70
Electrical	120.10
Instrumentation	118.60
Insulation	102.60
<b>Average</b>	<b>114.60</b>

**Table 18.5.8 Labour Productivity Factors**

Area	Factor
Civil General	Incl. in unit rates
Civil Piping	1.31
Civil Structural	1.30
Concrete	1.30
Structural Steel	1.32
Architectural	1.29
Building Services	1.29
Mechanical	1.35
Tanks and Vessels	1.35
Process Piping	1.29
Electrical	1.32
Instrumentation	1.25
Insulation	1.34

#### OPEN PIT MINE

The price of the main open pit mining equipment includes freight to Seattle and an allowance for on-site assembly. Transport costs from Seattle to site are included in the indirect costs (phase 8o).

Support equipment pricing is based on similar equipment used at other recent projects. Table 18.5.9 summarizes unit costs for open pit mining equipment.

The capital cost for the open pit mining component of each development case is derived by applying the unit prices per equipment in Table 18.5.9 to the respective open pit equipment requirements. Initial spare parts stock has been estimated at 8% of the value of the mining equipment.

#### TAILINGS AND WASTE MANAGEMENT

Capital costs for tailings, waste, and water management have been derived separately from those for mine infrastructure and services.

With regard to pipeworks and pumps:

- steel price of \$980 per ton has been used to derive the cost of steel piping;
- material costs for pumping systems have been developed existing data; and
- unit rates for installation of pumps and pipelines have been derived from existing data.

**Table 18.5.9 Open Pit Mining Equipment Unit Costs**

Open Pit Mining Equipment	US\$000
<i>Main Equipment</i>	
Drills	6,012
Shovel	29,205
Wheel Loader	7,650
Hydraulic Shovel	20,157
Haulage Truck	5,795
Bulldozer	1,898
Wheel dozer	1,973
Grader	786
Water Truck	2,952
<i>Support Equipment</i>	
Secondary Drill	950
Backhoe Excavator	1,250
Service Truck	360
Low Bed Truck	2,000
Service Loader	550
Fuel Truck	500
Mobile Crane	700
Tire Handler	400
Cable reel	300
Motivator	900
Pumps	60
Dispatch and Radio	6,000
Pickup Truck	50
Snow Cat	900
Lighting Plants	50
Surveying and Radar	1,000
Hardware and Software	1,000
Ambulance	200
Fire Truck	350

## ROAD CORRIDOR PIPELINES

The road corridor pipelines will deliver concentrate from the mine site to Port Site 1, return water from Port Site 1 to the mine site, natural gas from the east side of Cook Inlet and diesel fuel from Port Site 1 to the mine site. The four pipelines will be buried in a common trench and will share the access road right of way. Common resources will be utilized for construction activities.

Crossings will generally be bored under rivers and streams. At longer crossings, the pipeline will be supported on the road bridge. Where not buried underground, the pipes will be encased in a protective layer. A cathodic protection system serving all three pipelines is provided to prevent external corrosion.

An allowance has been made for a leak detection system, which will also assist in the detection and prevention of slack flow the pipeline. A SCADA system will monitor and control the pumping facilities by means of a fibre optic line buried in the pipeline trench alongside the pipelines. Instruments such as pressure and temperature transducers located along the pipeline route will be tied into the fibre-optic link.

## ACCESS ROAD

Costs for construction of the access road have been based on a breakdown of anticipated quantities for the road earthworks and some associated materials. The road quantities include volumes for pipeline corridor clearing and for rock trench drill and blast where the pipelines coincide with the road alignment. To develop construction quantities, the road route has been divided into a number of segments based on terrain type and geotechnical qualities. Representative cross-sections have been then developed for each segment, from which construction quantities have been estimated.

## PORT FACILITIES

Costs for off-shore port facilities have been estimated based on historic costs and estimates for similar steel sheet pile bulkheads adjusted to reflect a remote Alaska site and work conditions.

- *Fill material* – All fill material will be produced from on-site blasting of bedrock to produce shot rock fill of varying gradations. The volume of fill has been calculated using AutoCAD Civil 3D and verified by average end-area hand calculations.
- *Sheet pile* – All sheet piling and accessories are hot-dip galvanized for corrosion protection and will be embedded 15 ft into the seabed. Tail wall lengths have been determined from the face sheet length plus 20% for seismic and global stability.
- *Dolphins* – The four mooring dolphins consist of three 24 inch piles, each with a prefabricated steel cap. The four breasting dolphins consist of five 24 inch piles, also with prefabricated steel caps. The piles will bear on bedrock with rock anchors. Heavy-duty fender assemblies are attached to each breasting dolphin. All steel piling, fender and accessories are hot-dip galvanized for corrosion protection.
- *Conveyor foundation* – The loadout conveyor foundations are two-pile bents placed every 100 ft from the concentrate storage building to the shiploader pivot under the conveyor. The

bent is an assembly of two 24 inch piles and rolled steel bent with stiffeners and necessary plates. The piles will bear on bedrock with rock anchors.

- *Shiploader foundation* – The foundation and layout are based on the Krupp Quadrant Shiploader. The reinforced concrete beam is 4 ft wide x 3.75 ft deep supported every 28 ft with a three-pile support structure. A four-pile structure is provided at one end for a tie-down structure. All piles will bear on bedrock with rock anchors. The pivot structure consists of seven 24 inch diameter piles and a 300 ft<sup>2</sup> x 10 ft thick reinforced concrete pad.
- *Catwalks* – Aluminum catwalks are provided along the concrete beam and between mooring and breasting dolphins. Approximately 1,110 ft of 4 ft wide catwalks are included.
- *Loading apron and concrete face beam* – A 100 ft wide x 543 ft long reinforced concrete apron and face beam will be constructed along the barge unloading area. The apron is 12 inches thick x 90 ft wide, the face beam 24 inches thick x 10 ft wide. A bullrail assembly is attached to the surface of the face beam along the dock face. All pipes and accessories are hot-dip galvanized for corrosion protection. Light-duty fenders consisting of 18 inch diameter steel piles with HDPE sleeves are provided for barge loading and off-loading along the concrete beam. The piles will be embedded 17 ft into the seabed. Ten bollards consisting of 14 inch x 36 ft long piles are provided for securing barges and tugs during loading and unloading operations.
- *RO-RO ramp* – The roll-on/roll-off ramp consists of a pile-supported offloading ramp, catwalk and breasting dolphins. All pipe piles are 24 inch diameter. The piles will bear on bedrock with rock anchors.

## PROCESS PLANT AND MILL SITE FACILITIES

### *Summary*

Capital costs for the process plant and mill site facilities cover the following facilities:

- plant site development;
- process facilities;
- ancillary facilities (administration, truckshop, warehouses, assay laboratory, site camps);
- utilities (power distribution, water distribution, fuel storage and distribution, heating system, control systems);
- port site process and materials handling facilities;
- indirect costs, other than items specifically included in the direct estimates;
- logistics;
- construction execution; and
- commissioning.

### *Estimate Support Documents*

The following documentation has been used as the basis for the capital cost estimates:

- design criteria;

- regional climatic data;
- process flowsheets;
- equipment list;
- general arrangement drawings;
- supplemental sketches as required;
- single-line electrical drawings;
- quantity take-offs;
- equipment budget quotations from vendors;
- estimates of quantities and/or costs from consultants;
- in-house data;
- project WBS;
- quantities in imperial units of measure; and
- project development schedule.

*Direct Cost Estimate*

Equipment and Material Costs

The equipment pricing has been based on a combination of re-pricing of some major equipment, as shown in Table 18.5.10, and factoring the remaining equipment from 2008 quotations. Specifications have been prepared for the equipment shown in Table 18.5.10 and updated pricing received from the selected equipment suppliers.

**Table 18.5.10 Major Equipment Re-Priced**

Equipment Description	
SAG Mills (OASC)	Semi-Mobile Crushing Plant (OASC)
Ball Mills (OASC)	Conveyor Systems
Pebble Crushers (OASC)	HV Circuit Breakers
Flotation Tank Cells	HV Disconnect Switches
Flotation Column Cells	Transformers
Thickeners	Switchgear
Vertimills	Variable Frequency Drives
Concentrate Filters	Motor Control Centres
Cyclone Feed Pumps	Communications
Belt Feeders	Mill Motors
Shiploader	Conveyor Drive

Engineering material take-offs were based on neat quantities from project drawings and sketches. Items such as over-pour, material wastage, fittings and connections were included in the unit costs as allowances.

Material costs have been estimated based on quotations, developed costs such as concrete and aggregate production, in-house data or allowances. A summary of materials costs and their data source is shown in Table 18.5.11.

Material cost has been also identified by the base currency of the source quotation, although this may not represent the original source for the particular materials. A summary of materials costs and their currency source is shown in Table 18.5.12.

**Table 18.5.11 Material Cost Source**

Area	Previous Quote	Developed	In-House	Allowance	Third-party Consultant	Total
Site Works	-	83	1	-	17	60.51
Civil Piping	-	65	7	7	21	14.61
Civil Structural	-	59	35	3	3	10.63
Concrete	-	91	8	-	1	56.71
Structural Steel	94	-	1	2	3	68.35
Architectural	11	-	10	42	37	55.63
Building Services	11	-	10	74	5	8.31
Mining/Mobile	-	-	74	-	26	42.61
Mechanical	91	-	7	1	1	365.75
Mechanical Bulks	13	-	84	3	-	25.63
Tanks and Vessels	-	-	84	16	-	5.50
Process Piping	-	-	26	73	-	15.92
Electrical	79	-	15	6	-	234.64
Instrumentation	15	-	4	81	-	20.93
Insulation	3	-	97	-	-	0.33
Indirects	10	55	3	28	3	372.75
<b>Total (%)</b>	<b>46</b>	<b>24</b>	<b>11</b>	<b>14</b>	<b>5</b>	<b>100</b>
<b>Total (\$M)</b>	<b>634.45</b>	<b>321.58</b>	<b>153.15</b>	<b>185.93</b>	<b>63.69</b>	<b>1,358.81</b>

Note:

Previous Quote – Costs based on one or more vendor quotations from 2008 or 2009

Developed – Costs calculated or derived from combination of quotations and in-house data, specific to project

In-house – Costs derived from similar equipment or materials from in-house quotations or developed costs

Allowance – Costs based on engineering or estimating judgement and unsupported with engineering data or calculations

**Table 18.5.12 Currency Cost Source – Materials**

Area	AUS (%)	CAD (%)	Euro (%)	USD (%)	Total (\$M)
Site Works	-	-	-	100	60.51
Civil Piping	-	-	-	100	14.61
Civil Structural	-	-	-	100	10.63
Concrete	-	-	-	100	56.71
Structural Steel	-	4	-	96	68.35
Architectural	-	-	-	100	55.63
Building Services	-	-	-	100	8.31
Mining/Mobile	-	-	-	100	42.61
Mechanical	1	12	12	76	365.75

Table continues...

...Table 18.5.12 (cont'd)

Area	AUS (%)	CAD (%)	Euro (%)	USD (%)	Total (\$M)
Mechanical Bults	-	-	-	100	25.63
Tanks and Vessels	-	-	-	100	5.50
Process Piping	-	-	-	100	15.92
Electrical	-	-	-	100	234.64
Instrumentation	-	-	-	100	20.93
Insulation	-	-	-	100	0.33
Indirects	-	9	-	91	372.75
<b>Total (%)</b>	<b>0.2</b>	<b>6</b>	<b>3</b>	<b>91</b>	
<b>Total (\$M)</b>	<b>2.94</b>	<b>78.28</b>	<b>42.97</b>	<b>1,234.62</b>	<b>1,358.81</b>

### Civil

Earthworks quantities have been based on 5 ft contour data and preliminary modeling of the plant site. Quantities for plant site roads and outlying areas have been based earlier estimates, which were by typical cross-section.

All bulk earthwork quantities have been taken off from the 3D model software, neat in place (net), with no allowance for swell or compaction of materials. Industry-standard allowances for swell and compaction have been incorporated into the unit rate. Unit and work hour rates have been based on information and productivities received from published rates. Any costs related to downtime, weather delay or standby are included in indirect costs.

Construction costs for the bulk earthworks have been based on the following:

- Equipment productivity – Allowance of 15% loss on earthwork activities, seasonal work schedule, machine efficiency, downtime, shift turnaround, weather delay and site conditions, and 10 hour single shift.
- Equipment cost – Based on rental rates. All mobilization and demobilization costs are included in labour rates. No allowance for standby time or equipment transportation time is included.
- Equipment fuel consumption – Based on publicly-available manufacturer's data, using medium burn figures.
- Haulage equipment for tailings dam construction – Based on 90t trucks for rock quarry supply, mine haul trucks for zone C rockfill on tailings dam, and 40 ton trucks for placing of tailings dam filter material.
- Haulage equipment for general plant site materials – Based on 40 ton trucks for material handling.
- Clearing and grubbing – Assumes all spoils and trees to be treated/burned locally.
- Blasted rock cut from plant site and Port Site 1 – To be hauled to stockpile for the access road construction.



- Processed fill material – To be provided by an on-site central operated crusher. Material source from nearby borrow pit or free delivery from mine pre-production (except access road construction mentioned above).
- Rockfill for zone C in the tailings dam – Delivered by mine trucks. Mine truck operating costs are included in the rates from the point of transfer.
- All cut slope stabilization – Not included.
- Construction of avalanche protection – Not included.
- Pipe trenching along the access road – Pre-blasted, and cost included in the unit rates. Trench excavation and backfill is not included.
- Over excavation and fill costs – Included in the unit rates.
- Tailings dam toe grout curtain and seepage soil bentonite cut-off-wall – Based on existing rates.
- Equipment unit rates – Include diesel fuel at \$3.05/gal.

### *Civil Structural*

Detailed excavation and backfill quantities have been developed for each area. Retaining walls, including detailed backfill quantities, have been developed for the primary crusher area. Quantities have been based on preliminary general arrangement drawings. In-house data have been used for the retaining wall structure and installation.

### *Civil Piping*

Civil piping includes all overland HDPE and carbon steel pipe for water systems and diesel fuel distribution. Exterior piping has been based on contour and profile drawings. Grade preparation, pipe berms, excavation and backfill have been calculated separately. Overland piping has been taken off by material specification, size and line length.

Costs for hydro testing are included in the installation estimate. A design allowance of 4% has been included on the pipe materials for pipe and fitting routing variances. Material pricing for civil and infrastructure piping has been obtained from quotations.

### *Concrete*

Concrete quantity estimates have been developed from first principles based on drawings and sketches prepared to prefeasibility study level. Quantities for some ancillary buildings have been factored based on a revised building size.

The unit costs include an allowance for over-pour and wastage of 5%, preparation of aggregate material, transport and stockpiling, supply of cement, batching of concrete, placing, finishing, formwork and reinforcing steel.

### *Structural Steel*

Steel quantities are based on material take-offs derived from preliminary drawings and sketches. The coarse ore storage building structural steel quantities have been based on a computer model. Light, medium, and heavy steel quantities include a 15% allowance for fitting and connections. The unit price includes steel purchase, detailing, fabrication, and erection labour.

Quotations for pre-engineered buildings and structural steel supply were received in 2008.

### *Architectural*

Budget quotations have been received for the permanent and construction camps. The quotation for the permanent camp has been updated based on the size quoted in 2008, which has been then ratioed for the revised room requirement. Estimates for all other buildings and architectural finishes are based on in-house data. Internal finishings are estimated based on allowances.

### *Mechanical (Equipment)*

The mechanical equipment descriptions, quantities, size, and kW have been derived from the project mechanical equipment list. Except for the mill motors, electric or hydraulic motors have been itemized and priced with the equipment. Budget quotations have been received from the selected supplier in 2008. The pricing has been based on quotations representing 92% of the mechanical equipment costs.

Costs for other equipment have been based on existing pricing. A design allowance of 5% on equipment under \$2 million and 2% on equipment over \$2 million is included in the equipment price.

Quantity take-offs have been provided for all plate-work items. Take-offs includes allowances for stiffeners, fabrication details, and cut and waste. Pricing has been based on in-house data. A design allowance of 5% has been included in the equipment price.

Tank pricing is based on in-house data and includes a 5% design allowance.

HVAC systems are based on allowances.

### *Water Treatment Plant*

Capital costs for the water treatment plant (WTP) have been factored on WTP feed flow changes.

Capital for the WTP is split into an “initial capital” and a “sustaining capital” component, assuming the WTP will be expanded in 2018 as the mine increases in size.

### *Construction Equipment*

An allowance for rental of construction equipment for the entire mine plant site and port site has been included based on a rental cost per each direct hour, as shown in Table 18.5.13. Owner purchase of cranes over 90 tons and other major equipment is included in the indirect costs.

**Table 18.5.13 Construction Equipment Rental Costs**

Area	\$/h
Civil General	Incl. in unit rates
Civil Piping	15.00
Civil Structural	Incl. in unit rates
Concrete	9.00
Structural Steel	20.00
Architectural	5.00
Building Services	8.00
Mechanical	17.00
Tanks and Vessels	17.00
Process Piping	15.00
Electrical	15.00
Instrumentation	5.00
Insulation	8.00

### *Piping*

Process piping within the battery limits of the process plant is based on an equipment factor allowance. General arrangement drawings served as the base documents.

### *Electrical*

The electrical estimate is based on single-line diagrams and connected loads detailed in the mechanical equipment list. Major electrical equipment prices are based on quotations. Other equipment, bulk materials, and modular equipment rooms are priced with recent in-house data plus a 2% design allowance.

Quantities are prepared from primary power supply up to and including motor control centres (MCCs) and starters. Low voltage quantities from MCCs to motors are based on a percentage of mechanical equipment.

Building lighting, convenience receptacles and grounding estimates are based on a cost per square foot basis.

### *Instrumentation*

The plant distributed control system (DCS) and/or programmable logic controller (PLC) cost estimates include vendor support for programming and system configuration. The IT communication network is based on an Ethernet network on a fibre-optic backbone. Pricing is based on quotations for the DCS system and in-house data for the remaining equipment.

Instrumentation within process area battery limits is an allowance based on a percentage of mechanical equipment.

## POWER GENERATION FACILITIES

### *Power Plant*

Capital cost estimates for power generation include both the cost of the power plant and the cost of the natural gas pipeline from the east side of Cook Inlet to the mine site, a distance of approximately 200 miles.

The cost estimate for the mine site power plant is based on a parametric methodology developed from numerous regional projects, adjusted for local Alaskan conditions. Verbal budgetary quotes have been obtained for all major equipment components. Specific assumptions are listed below:

- capital costs for start-up spares are included but warehousing spares have been excluded;
- major equipment spares for routine maintenance are included in the operating costs;
- costs are included for the turbine generator, enclosure, and switchgear at the port site;
- the site is assumed to be in usable condition with no major earthworks required except foundations and pads and rough grading costs are within the overall plant site grading costs;
- off-site fabrication will be used where practical;
- all construction and O&M labour assume union labour (Alaska's Little Davis Bacon standard wages);
- construction equipment rates are those for non-remote areas of south central Alaska;
- all-in construction labour rates includes labour, supervision, construction equipment, payroll burdens, temporary construction, contractor overhead and profit, for a total of \$158/direct work hour and premium pay.
- overtime will be required to attract labour;
- the work shift is assumed 12 hours per day which is consistent with the overall Pebble project work schedule;
- camp and per diem costs are included in the overall indirects estimate;
- productivity loss due to the extended work week is assumed to be 20%;
- productivity other than that due to extended work week is assumed to be normal;
- no factor has been included for an imported work force; and
- no winter work productivity reduction factor has been assumed as outside work is scheduled in summer months.

Material cost adjustments include:

- overall 3% of material and equipment for additional freight;
- allowance for site-specific requirements such as low-temperature steel; and
- materials to be purchased locally whenever practical.

### *Natural Gas Pipeline Costs*

Rough order-of-magnitude estimates for the three natural gas pipeline segments and associated facilities have been prepared using a bottom-up approach. The estimates include facilities such as pigging (smart pig), custody transfer metering, relief and compression. The cost for the pipeline tie-in on the east side of Cook Inlet has been benchmarked against other natural gas pipeline estimates on the Kenai Peninsula. No recent sub-sea pipelines have been constructed in Cook Inlet; therefore, no benchmark information has been available. The gas pipeline from the port site to the mine site is assumed to be laid in a common trench with the concentrate and water return lines. The facilities are assumed to be truckable modules fabricated in south-central Alaska.

Cost estimates include materials, fabrication, installation, construction management and engineering.

#### 18.5.7 INDIRECT COST ESTIMATE

##### OWNER'S COSTS

Project-related Owner's costs are based on the four year period from the Notice to Proceed to the end of plant commissioning. Owner's costs include:

- operations staff ramp-up including salaries, bonus and incentives, travel and relocation;
- project execution staff ramp-up including salaries, bonus and incentives, travel and relocation;
- project insurance;
- community relations;
- environmental monitoring;
- corporate expenses;
- Anchorage office expenses; and
- costs for power during the period between commissioning of the power plant to completion of process plant commissioning.

##### CONTINGENCY

###### *Definition*

Contingency in this capital cost estimate has been defined as an allowance to cover unforeseen items within the scope of the estimate and is expected to be spent. The American Association of Cost Engineers (AACE) refers to contingency as an amount added to an estimate to allow for items, conditions or events that are uncertain and that experience shows will likely result in additional costs.

###### *Inclusions*

The contingency estimate covers unforeseeable items that can arise due to currently undefined areas of work or equipment, or uncertainty in the estimated quantities and unit prices for labour, equipment, and materials. Some of the items, conditions or events for which the state, occurrence

and/or effect is uncertain include: planning and estimating errors and omissions; minor price fluctuations (other than general escalation); design developments and changes within the scope; and variations in market and environmental conditions.

### *Exclusions*

The contingency estimate does not cover scope changes or project exclusions such as:

- major scope changes such as changes in end-product specification, capacities, building sizes and location of the asset or project;
- extraordinary events;
- management reserves; and
- escalation and currency effects, which are handled in the financial model.

### *Contingency Estimate Methodology*

The contingency estimate has been originally compiled from a special working session, during which a risk matrix has been applied to all estimate areas. The basis of the estimate has been further refined by applying a weighting factor to each contingency estimate line, based on its relative cost magnitude. This resulted in a contingency factor of 17.7%.

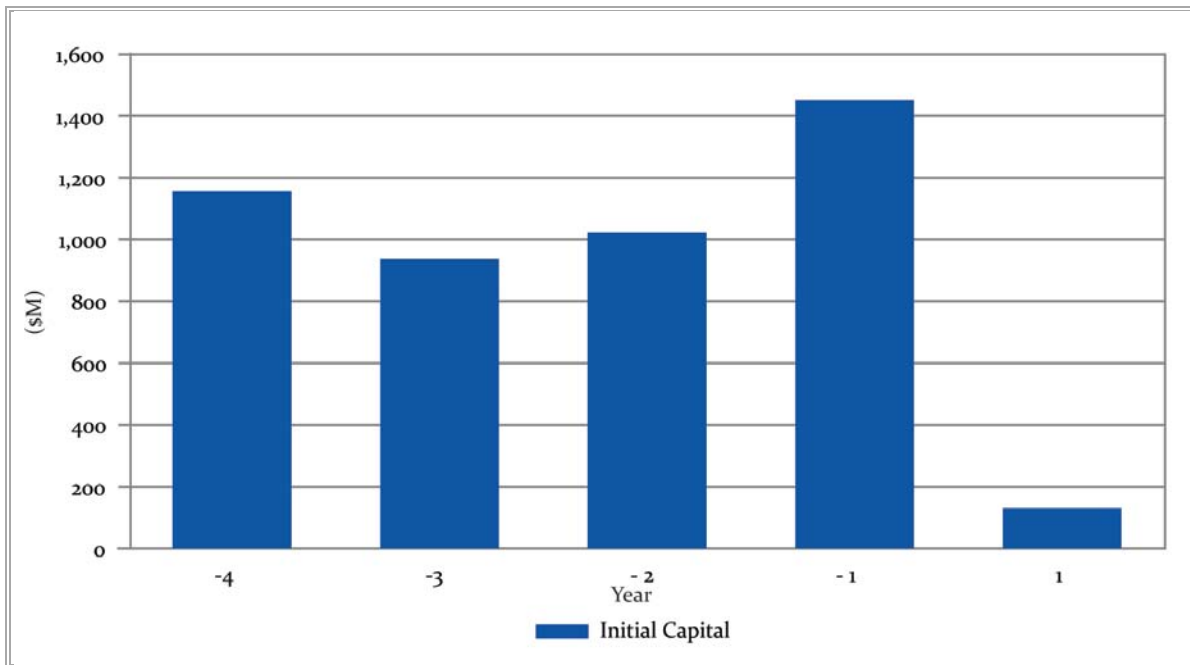
### **RISK**

No allowance has been made in the estimate for unforeseeable areas of risk.

#### **18.5.8 CAPITAL EXPENDITURE PHASING**

The phasing of initial capital spend is illustrated in Figure 18.5.1. The capital plan estimates that approximately \$100 million of Year -4 mining equipment (including indirect costs) will have to be ordered in advance of the construction commencement date.

**Figure 18.5.1 Pebble Project – Initial Capital Phasing – All Cases**



**18.5.9 ASSUMPTIONS AND EXCLUSIONS**

**ASSUMPTIONS**

The following assumptions have been made to prepare this estimate:

- all material and equipment purchases and installation subcontracts will be competitively tendered on a lump sum or unit rate basis;
- all equipment and materials will be new;
- the work week for the construction phase of the project will be 84 hours long;
- skilled tradespersons, supervisors and contractors will be available; and
- there will be no financing or cash flow constraints.

**EXCLUSIONS TO THE CAPITAL ESTIMATE**

The following items are not included in the capital cost estimate:

- escalation;
- scope changes;
- interest during construction;

- cost of schedule delays such as those caused by:
  - scope changes;
  - unidentified ground conditions;
  - labour disputes; and
  - extreme weather including extended white-outs;
- cost of financing;
- acquisition costs;
- sunk costs;
- additional studies;
- exploration expenses;
- sustaining capital;
- closure costs;
- reclamation cost;
- duties;
- currency fluctuations;
- any provision for force majeure;
- changes in law of the United States of America;
- licenses, royalties and commissions;
- changes to design criteria;
- additional studies or investigations prior to EPCM; and
- pandemics.

#### 18.5.10 SUSTAINING CAPITAL

For the purposes of this section, sustaining capital in all areas is defined as capital expenditures incurred after the process plant is ready to receive its first feed (end of year 4<sup>th</sup> year of construction – year -1).

Sustaining capital requirements for the Pebble Project for all 3 development cases are shown in Table 18.5.14.

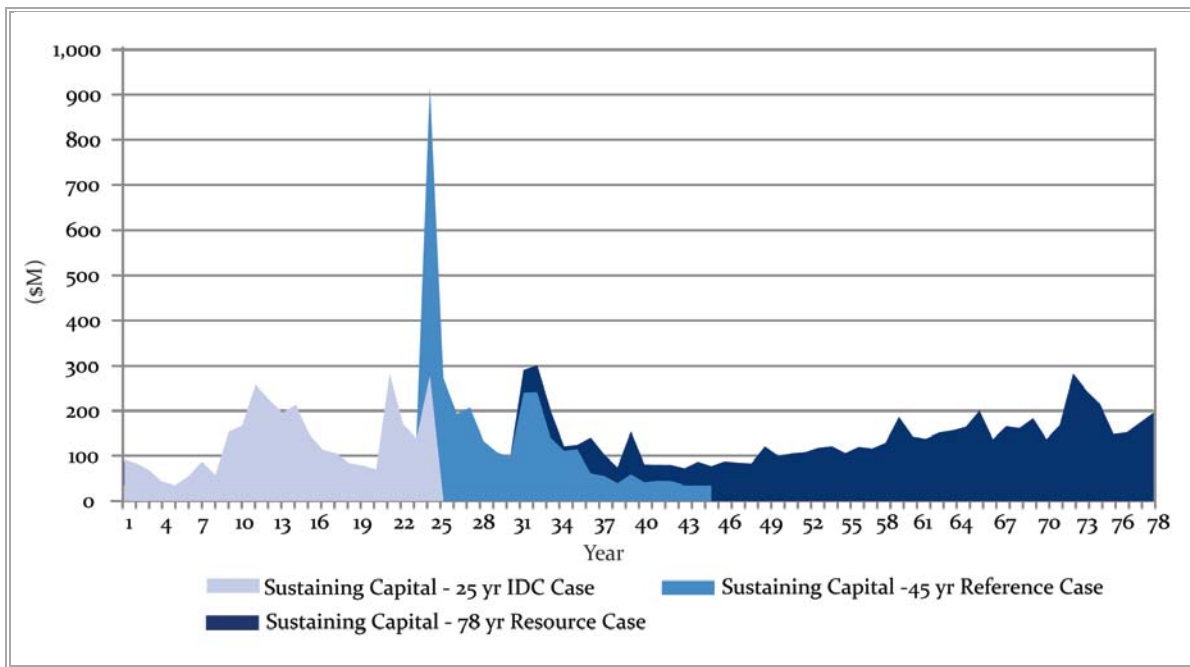
The sustaining capital profile of the 45-Year Reference Case and the 78-year Resource Case continue the assumptions of sustaining capital requirements of the 25-year IDC case. The phasing of all three cases is illustrated in Figure 18.5.2 with each developing case building off assumptions of the preceding mine plan respectively.



**Table 18.5.14 Pebble Project – Sustaining Capital Costs (\$M) – All Cases**

Area	IDC Case	Reference Case	Resource Case
Open Pit	2,047	3,286	7,225
Processing	146	230	517
Infrastructure	12	165	165
Waste Management	846	2,211	3,364
Other	70	104	180
Molybdenum Autoclave	83	144	276
<b>Total</b>	<b>3,204</b>	<b>6,140</b>	<b>11,727</b>

**Figure 18.5.2 Pebble Project – 78-year Reference Case Sustaining Capital Phasing (\$M)**



**18.5.11 MINE CLOSURE**

Closure costs are not included in the estimate but are covered in the financial section.



## 18.6 OPERATING COST ESTIMATE

### 18.6.1 SUMMARY

The life of mine average unit operating cost estimate is \$11.16/ton milled for the 25-year IDC Case, \$11.55/ton milled for the 45-year Reference Case and \$14.72/ton milled for the 78-year Resource Case.

**Table 18.6.1 Operating Cost Estimate – 45-Year Reference Case (LOM Average)**

Item	Unit	IDC Case	Reference Case	Resource Case
Total Operating Cost (LOM)	\$M	22,208	43,489	96,063
Total Operating Cost per ton	\$/ton	11.16	11.55	14.72

The operating cost estimate is shown as an annual cost for each calendar year of the project life from plant start-up to mine closure. The operating cost estimate is based on a process plant throughput rate ranging between 200,000 tons per day (71 million tons per year based on 355 days per year) and 275,000 tons per day (97 million tons per year).

The operating costs are grouped into six cost centers:

- open pit mining;
- process (including process facilities at port);
- tailings management (exclusive of ongoing construction);
- transportation;
- environmental; and
- general & administration (G&A).

The 45-year Reference Case/ton milled cost estimate is summarized by cost centre and area in Table 18.6.2.

**Table 18.6.2 Operating Cost Estimate – 45-Year Reference Case (LOM Average)**

Cost Per Ton Milled	Labour (\$/ton)	Power (\$/ton)	Material (\$/ton)	Fuel (\$/ton)	Lease (\$/ton)	Other (\$/ton)	Total (\$/ton)
Open Pit Mining	0.75	0.06	2.32	1.17	-	-	4.30
Process	0.38	1.19	2.46	0.02	-	0.02	4.07
Tailings	0.13	0.15	0.18	0.07	-	-	0.53
Transportation	-	0.01	0.01	0.02	0.35	0.53	0.92
Environmental	0.03	0.02	0.20	-	-	0.04	0.29
G&A	0.31	0.02	-	0.01	0.78	0.32	1.44
<b>Total</b>	<b>1.60</b>	<b>1.45</b>	<b>5.17</b>	<b>1.29</b>	<b>1.13</b>	<b>0.91</b>	<b>11.55</b>

## 18.6.2 SCOPE OF WORK

The operating cost estimate includes all costs associated with the open pit mining of ore and waste, the processing of the ore to a final concentrate and all the services required to support this operation. It does not include ocean freight of the final concentrate or associated smelter charges; these are covered in the off-site charges in the financial analysis.

## 18.6.3 BASIS OF ESTIMATE

This section describes the cost components associated with all cost centers including labour-related items, fuel and unit power cost. The basis of estimate for the individual cost centers is discussed hereunder.

### LABOUR

Table 18.6.3 lists the number of employees on the payroll at two representative points during the mine life.

**Table 18.6.3 Number of Employees on Payroll**

Area	Year 2	Year 18
Mine Site	747	1,196
Port Site	32	32
Off-Site	51	50
<b>Total Staff</b>	<b>830</b>	<b>1,278</b>

### PERSONNEL ROTATION

All non-exempt, supervisory and junior technical personnel posted to the mine or port sites will work a 2 and 1 rotation (14 day shifts / 7 days off, 14 night shifts / 7 days off). Management staff and senior technical personnel will work the same rotation. All staff posted to an off-site office will work a normal workweek schedule and will commute to that office.

Personnel will be rotated to a defined point of hire, either local villages in the Lake and Peninsula Borough, the Bristol Bay region, Anchorage or the Kenai Peninsula. Personnel will be assigned to designated crews and therefore commute time, including transport between the airport and site, will be during the no-work part of the rotation schedule. Employees will be expected to continue to report to work if their rotation transport is delayed. Employees who are delayed in returning to site will be expected to be available for rescheduled transportation. It is anticipated that personnel who live in local villages connected to the transportation system will be able to commute daily from that location.

Non-exempt employees will be paid for additional hours worked according to appropriate labour laws. No payment will be made for non-worked hours for non-exempt employees delayed in returning to site. Exempt employees will have no adjustment to salary or time off for commute travel disruptions.

Rotation air rates were based on quotations for daily weekday service.

## RECRUITING

Recruiting costs will cover advertising for positions, recruiting firms, and interview costs, including travel, relocation costs, and housing assistance.

The annual turnover rate was assumed to be 15%.

## MINE SITE CAMP REQUIREMENTS

The mine camp requirements were based on the following assumptions:

- all staff on 2 and 1 work rotations and supervisory personnel will have a dedicated room;
- allowance has been made for 25 larger rooms to serve as wheelchair accessible facilities or to accommodate married employees;
- allowance was provided for 15 visitors;
- a shared toilet and shower facility has been allocated to every two rooms;
- each room will have a separate sink;
- amenities will include: a gymnasium with volleyball court/half-court basketball; workout room; weight room; games room; television room; smoking lounge; lounge; commissary and Internet café;
- dining messing facilities will be capable of seating all staff on site over a three-hour period straddling shift breaks, with two hot meals served daily; and
- bag lunch facilities.

The camp will operate under a zero-tolerance policy with respect to alcohol and drug possession and consumption.

## PORT SITE CAMP REQUIREMENTS

The port site camp will be set up for two categories of employees. The first are those employees who will be permanently assigned to the port to operate and maintain the concentrate storage and filtration facility, camp and freight and fuel marshalling. The room standards for these employees will be similar to those established at the mine site. The second category will be for overnight personnel, such as road transport drivers, visitors, maintenance crews from site and technical representatives.

## CATERING

The cost of catering at all permanent camps has been estimated from quotations and includes cooking labour, food supply, linen and towels, janitorial and laundry, general building services and maintenance. Sewage treatment and incineration are included in G&A and accommodation-related transportation costs are included with the other transport costs.

Wages, Salaries and Loading Table 18.6.4 shows the loaded labour rates for the different levels of employees. Salaries include a remote site allowance for on-site employees.

**Table 18.6.4 Labour Rates – Annual Loaded Salary with Bonus, Rounded**

Department	Code	Off-site		On-site	
		Exempt 5 days (\$)	Non-Exempt 5 days (\$)	Exempt 1-Feb (\$)	Non-Exempt 1-Feb (\$)
Administration	Level 2	169,200	-	221,700	-
	Level 3	117,000	-	153,200	-
Electrical Generation and Transmission	Level 2	-	-	221,700	-
	Level 3	-	-	-	143,100
	Level 4	-	-	-	120,500
	Level 5	-	-	-	105,600
Infrastructure	Level 2	-	-	221,700	-
	Level 3	-	-	-	153,200
	Level 4	-	-	-	125,500
	Level 5	-	-	-	104,600
Management	Level 0	242,400	-	-	-
	Level 1	240,600	-	240,600	-
	Level 4	-	90,980	-	-
Open Pit	Level 2	-	-	221,700	-
	Level 3	-	-	-	153,200
	Level 4	-	-	-	125,500
	Level 5	-	-	-	104,600
Port	Level 2	-	-	221,700	-
	Level 3	-	-	-	153,200
	Level 4	-	-	-	125,500
	Level 5	-	-	-	104,600
Process	Level 2	-	-	221,700	-
	Level 3	-	-	-	153,200
	Level 4	-	-	-	125,500
	Level 5	-	-	-	108,100
Tailings Storage Facility	Level 2	-	-	221,700	-
	Level 3	-	-	153,200	-
	Level 4	-	-	-	125,500
	Level 5	-	-	-	108,100

Loading for both exempt and non-exempt employees includes:

- statutory loading of Federal Insurance Contribution Act (FICA), Medicare, State Unemployment Insurance (UI) and Federal Unemployment Insurance (FUI);
- workers' compensation;
- employee benefits of health, extended health, dental, formal vacation, insurance and retirement; and

- vacation and short-term absences for non-exempt employees will be covered by additional personnel as follows:
  - on-site – unplanned absence 2.9% (equivalent to seven days per year);
  - on-site – vacation allowance 8.6% (equivalent to 1½ rotations per year);
  - off-site – unplanned absence 1.0% (equivalent to five days per year); and
  - off-site – vacation allowance 2.9% (equivalent to three weeks per year).

Vacation and short-term absences for exempt employees will be covered by additional staff at the medium and lower levels.

#### FUEL

All fuel will be ultra low sulphur diesel (ULSD) at prices of \$2.69 per US gallons during construction and \$2.39 per US gallons for operations. The difference reflects the implementation of diesel pumping from the port as opposed to road transportation during construction.

#### POWER

Power will be produced on site from a combined-cycle natural gas-fired turbine plant. Costs associated with generating power (operating, maintenance, fuel and oil requirements) are included in the unit power cost. The power cost is estimated at \$0.066/kW hour based on a long-term natural gas price average of \$7/MBtu, compared to the current price of \$4.50/MBtu.

#### 18.6.4 OPEN PIT MINING

Unit mining costs are summarized in Table 18.6.5 for the 45-year Reference Case.

**Table 18.6.5 Open Pit Mining Cost per Ton**

Item	\$/ton mined	\$/ton milled
Labour	0.24	0.75
Power	0.38	1.17
Fuel	0.02	0.06
Machine Operation and Maintenance	0.42	1.29
Tires	0.10	0.29
Blasting	0.15	0.46
Dewatering	0.03	0.08
Re-handling	0.01	0.03
In Pit Crushing and Conveying	0.06	0.17
<b>Total</b>	<b>1.40</b>	<b>4.30</b>

Table 18.6.6 provides the mine management component while the mine operator and maintenance staffing level at five year increments for the 45 Year Reference Case are shown in Table 18.6.7. Staffing changes over the mine life correspond to changes in strip ratio.

**Table 18.6.6 Mine Management Component**

	Personnel
Mine Management	1
Technical Services	39
Operations	19
Maintenance	17
<b>Total</b>	<b>76</b>

**Table 18.6.7 Open Pit Operator and Maintenance Staffing**

	Mine Life Horizons (yr)									
	0	5	10	15	20	25	30	35	40	45
Operators	61	93	154	239	248	269	294	323	167	106
Maintenance	62	95	159	288	299	332	378	438	230	147
<b>Total</b>	<b>123</b>	<b>188</b>	<b>313</b>	<b>527</b>	<b>547</b>	<b>601</b>	<b>672</b>	<b>761</b>	<b>397</b>	<b>253</b>

### 18.6.5 PROCESS

Unit costs for processing average \$4.07/ton milled, with the key cost items are shown in Table 18.6.8 for the 45-year Reference Case.

**Table 18.6.8 Process Cost per Ton Milled**

Item	\$/ton milled
Power	1.19
Grinding Liners & Media	1.21
Reagents	0.46
Mechanical Equipment	0.23
Labour	0.38
Fuel	0.02
Gold Plant Excluding Labour	0.56
Other	0.02
<b>Total</b>	<b>4.07</b>

### 18.6.6 TAILINGS FACILITY

The tailings operating costs average \$0.53/ton milled over the life of the mine for the 45-year Reference Case. The operational areas include tailings placement, reclaim water, pit dewatering and seepage collection pumping. The costs include labour, power, pump and pipeline maintenance and ongoing pipeline extensions required for operations.

The operating costs were derived using the following rates and factors:



- electricity supply cost of \$0.066 per kilowatt hour;
- mobile equipment for operations crews and pipe relocations based on the publicly-available rates; and
- maintenance costs based on a percentage of the installed work and materials costs.

The labour and material proportions of the total tailings maintenance costs shown in Table 18.6.9.

**Table 18.6.9 Labour and Materials Proportions for Tailings Maintenance Costs**

Description	% Work Hours	% Material
Mechanical Equipment – Slurry Pumping Systems	25	30
Mechanical Equipment – Water Pumping Systems	15	15
Instruments and Computers	10	10
Civil and Earthworks	0	0
Structural Steel	2.5	2.5
Electrical Equipment	20	10
Piping and Valves	20	15
Buildings	2.5	2.5
Linings and Coatings	2.5	2.5

### 18.6.7 ENVIRONMENTAL MANAGEMENT COSTS

#### SUMMARY

Environmental operating costs average \$0.29/ton over the life of the mine for the 45-year Reference Case. The costs are associated with the following activities for the mine, road and port areas:

- baseline studies and monitoring;
- field monitoring equipment;
- environmental laboratory supplies;
- outside laboratory analysis;
- fuel and maintenance for vehicles associated with environmental operations;
- project permitting;
- wetlands mitigation;
- fish and wildlife mitigation and enhancement;
- a water treatment plant operations and maintenance; and
- environmental consultants.

## BASELINE STUDIES, PROJECT PERMITTING AND PUBLIC AFFAIRS/COMMUNITY RELATIONS

During operation of the mine, environmental monitoring will be required. This monitoring will include water quality, aquatic habitat, wildlife, air quality and other conditions. Community relations and public affairs activities will continue during operations and into the closure phase of the project to ensure that the mine site is reclaimed and closed in a manner that is acceptable to the local residents, as well as being environmentally sound.

The estimated cost for environmental monitoring, management, permitting and community relations during the operations phase, plus 10 years of closure activities, is \$87 million for the 45-year Reference Case.

### 18.6.8 WATER TREATMENT PLANT

The water treatment plant (WTP) costs are summarized in Table 18.6.10 for the 45-year Reference Case.

**Table 18.6.10 Overall WTP Costs (LOM average)**

Component	Labour	Power	Material	Other	Total
Total Cost(\$M/yr)	0.74	0.88	3.18	1.51	6.31
Unit Cost (\$/ton milled)	0.01	0.02	0.05	0.02	0.10

### 18.6.9 TRANSPORTATION

Transportation operating costs average \$0.91/ton milled over the life of the mine for the 45-year Reference Case. These costs are related to the transportation of personnel from points of hire and all material (consumables, equipment, fuel) from the consolidation port of Seattle, or in the case of fuel, Anchorage, to Port Site 1. The costs associated with transporting the material from Port Site 1 to the mine site via the access road and maintenance of the access road is also included in this cost centre. Maintenance costs for the concentrate, water return and fuel pipelines are included here but the maintenance cost for the natural gas pipeline is excluded.

#### MATERIAL TRANSPORT

Table 18.6.11 summarizes the costs associated with the transport of personnel and material to the mine site for two representative operational years. These costs do not include maintenance of the access road and pipelines. The unit cost to transport freight from Seattle to the mine site is \$92.70 per ton.

**Table 18.6.11 Representative Material Transport Costs**

Materials and Equipment	Year 1 (\$M)	Year 20 (\$M)
Freight	33.31	35.59
Personnel Transport	5.31	5.23
Air Freight	2.70	2.51
<b>Total</b>	<b>41.32</b>	<b>43.33</b>

## ACCESS ROAD MAINTENANCE COSTS

The 86 mile long access road from the port to the mine site, will require daily maintenance. The operating costs are based on utilizing several small crews based at Port Site 1, the mine site and at least two other mid-route locations. Maintenance costs include crew and equipment, crushed road topping every five years, culvert, embankment, riprap, guardrail and river training structures, regular bridge and other inspections, dust suppression, snow removal and avalanche control and removal.

The estimated cost to maintain the road is \$5 million per year or \$58,000 per mile per year.

## PIPELINE MAINTENANCE COSTS

Maintenance costs for the concentrate, water return and fuel water pipelines amount to \$684,000 per year, or \$0.01/ton milled. This includes propane required to power remote monitoring stations, maintenance spares for pumps/valves, right-of-way maintenance and allowance for partial pipeline replacement.

### 18.6.10 GENERAL AND ADMINISTRATION

Life-of-mine G&A costs average \$1.44/ton milled for the 45-year Reference Case. These costs are associated with the operation both directly (including site services such as incineration, sewage treatment and camp maintenance costs) and indirectly (including camp costs and property taxes). The cost of operating off-site offices is also included in G&A costs. The estimate for the operating indirect cost is a combination of calculated values and allowances.

## MATERIALS

The material items included in the G&A cost centre include port site consumables such as fenders, buoys and mechanical spares as a percentage of the installed G&A mechanical equipment. They also include site road maintenance at the mine and port sites, excluding haul roads and the main access road, which are associated with the mining and transportation costs, respectively.

## POWER

The power associated with the G&A cost centre includes requirements for the process building, camps and potable fire and water distribution.

## OTHER DIRECT COSTS

Other direct G&A costs include those items not specifically related to labour, power or materials. Most of the items in this category are allowances, with some key aspects such as camp catering, insurance, recruiting and parental leave developed from first principles. Table 18.6.12 lists of the assumptions made for these key components.

**Table 18.6.12 Assumptions for Other G&A Costs**

Component	Assumption
Camp Catering	\$40/person/day for mill site, \$52/day for port site
Insurance	Includes property, terrorism, vehicle, aviation, business interruption and general liability insurance
Parental Leave	15% of workforce is female and 6% of employees take leave each year; men take 20 days leave, women 180; full pay received

#### OVERHEADS

Overheads relate to non-production items such as administration and human resources labour, insurance, IT support, legal fees, recruiting and security.

## 18.7 PROJECT EXECUTION PLAN

---

### 18.7.1 INTRODUCTION

A comprehensive Project Execution Plan (PEP) for the Pebble Project has been developed. The following overview is based on Wardrop's review of this information.

The PEP establishes a detailed plan for the engineering, procurement, logistics and construction management required to bring the project successfully to the permitting stage and into development.

Key project deliverables encompassed by the PEP include the development of:

- construction camps required for the various phases and sites;
- an all-weather site access road that links the permanent port facility to the mine site;
- a deep water port facility that will be the site for a concentrate dewatering plant and ship loading facility;
- an open pit mine feeding a nominal 200ktpd copper-molybdenum flotation plant;
- a tailings storage facility (TSF) near the plant site;
- site buildings including accommodations, offices and maintenance facilities;
- pipelines for transferring natural gas, diesel fuel, filtrate water return and copper concentrate between the port site and mine; and
- a combined-cycle natural gas-fired turbine power plant.

From receipt of permits, the estimated time required for procurement and construction to take the project into operation is 48 months.

After reviewing the opportunities afforded by modularizing the power plant, this concept has been incorporated into the overall project execution strategy. Thus, the design of certain components of the project, such as the access road, has been adapted to accommodate this construction approach.

### 18.7.2 HEALTH, SAFETY AND ENVIRONMENT

A stringent health, safety and environment (HSE) program has been identified as essential to overall project success. Therefore, a system of integrated principles has been designed to be implemented with the goal of achieving zero-harm for employees, contractors and visitors working on the project.

## SITE ENVIRONMENTAL PROCEDURES

All design and engineering stages incorporate criteria for responsible management of process flows, effluent and waste products to meet established capture and containment guidelines. The project design also incorporates basic clean plant design standards, including operational safety and maintenance access requirements. A Hazard and Operability Analysis (HAZOP) will be conducted by the project design team during the detailed design stage for each area of the project.

### 18.7.3 EXECUTION STRATEGY

#### MANAGEMENT EXECUTION PHILOSOPHY

The Owner's team will directly manage those project components to be completed in the early construction phases, including site earthworks, accommodations and service complex. Other expertise will be added to the team on an as required basis. Long-term operational management requirements for project infrastructure will be implemented prior to the initiation of mining operations. As commissioning of project components is sequentially concluded, project staff will be utilized in other key project areas.

#### RISK MANAGEMENT

The Owner's engineering team performs constant reviews, both internally and through data received via the contracting of independent, third party engineers, consultants and manufacturers, in an effort to continually identify and monitor potential risks and opportunities associated with the project, assess them against targeted outcome objectives, and determine the primary method for eliminating or controlling potential outcomes.

#### MANAGEMENT OF ENGINEERING DELIVERABLES

Responsibility for identification and scheduling of deliverables relative to the overall project schedule will be tasked to specific project engineering groups. In addition, the Owner's team will implement a document management system, complete with quality control program, to track deliverables and aid in successful project implementation.

#### PROJECT SCHEDULING AND PROGRESS REPORTING

Key milestones in the project schedule are shown in Table 18.7.1.

**Table 18.7.1 Key Milestone Schedule**

Milestone Description	Month
Board Approval	Project Start
Final Permits Issued for Construction	Month 3
Temporary Access to Site	Month 5
Permanent Access to Site	Month 9
Start Tailings Impoundment Facility	Month 20
Start Preproduction Stripping	Month 32
Complete Permanent Port Site 1 Dock	Month 38
Complete Tailing Impoundment Facility for Start-up	Month 41
Permanent Power Available at Site	Month 42
Process Plant – Line 1 Complete	Month 48
Commence Production	Month 48

#### COST REPORTING AND FORECASTING

A project Work Breakdown Structure (WBS) has been developed to define cost elements of the project scope, to be monitored and controlled on an ongoing basis. This structure will be used for the assignment of cost codes to invoices for the project. Once established, the cost report will become the governing cost reporting document for the project, and the capital cost estimate will become a reference document.

#### 18.7.4 ENGINEERING

##### ENGINEERING STRATEGY

The approach to engineering design is to utilize the best available proven technology for the project. The design is to be bench-marked against similar scale projects and global engineering standards.

Project systems and equipment will be designed to meet North American standards for northern climates. Where applicable, the use of pre-assembled or modular components will be implemented to reduce costs associated with transportation, site erection and other variable project components.

#### 18.7.5 PROCUREMENT AND CONTRACTS

##### PROCUREMENT AND EXPEDITING

The overall procurement strategy will utilize a global approach toward the minimization of capital expenditure, where applicable.

The Owner’s team, working in conjunction with representatives from the EPCM contractor, will procure all equipment and bulk items. A detailed procurement database will be developed in alignment with the project execution schedule, and will cover all requirements from enquiry issue through to award, expediting, inspection and final delivery. Finally, the Owner’s team, together with

QA and QC personnel, will conduct independent quality inspections and monitor major equipment delivery milestone dates.

## LOGISTICS

The logistics plan addresses issues related to mobilization to the site, construction operations and permanent operations. The logistics plan developed within the PEP and schedule, addresses logistical constraints presented by the complexity of the project.

The core of the plan is to construct a reliable and efficient transportation corridor between the port site and the mine site prior to shipping materials and supplies to construct the permanent site infrastructure. The logistics plan follows a project construction schedule of 48 months, with site road access from Port Site 1 established within 12 months of the start of construction.

Equipment, materials and supplies will be received and shipments consolidated at a marshalling yard located at Kitimat, British Columbia (B.C.), where deep-water shipping facilities are currently available. Additionally, the Canada National Railway (CNR) has direct rail car service to Anchorage, Alaska via Prince Rupert, B.C.; Rail barge is also available.

Logistics will evolve over the life of the project, as transportation infrastructure is developed. In general, it will fall into three phases:

- early mobilization access phase;
- temporary access phase; and
- permanent access phase.

The logistics plan outlines the requirements for each access phase.

## CONSTRUCTION STRATEGY

Construction crews will generally work a three week on, one week off rotation, with a focus on recruiting local labour to fill the crews. The use of contract labour for the Owner's earthwork fleet will be used until such time as the focus of work shifts to mine site. At that time, the Owner's operations team will begin recruiting full-time employees to operate equipment, with a focus on developing a core mining team during the construction phase prior to large open pit equipment arriving.

## MAIN SITE ACCESS ROAD

The mine site access road is key to the economic development of the project. As part of the scope of services, a review has been conducted of the timely and efficient construction of the access road from the port site to the mine site. The main site access road is discussed in further detail in Section 18.4.

Construction plans and estimates for the access road from the port site to the mine site have been prepared. The plan establishes access to site from a temporary landing at Williamsport within 10 months of start of mobilization. Work will continue for an additional five months to complete the



road upgrade between Williamsport and Pile Bay, and extend the road to Port Site 1. An additional barge mobilization will be required to establish support for road construction efforts.

#### PORT FACILITY AND ROAD ACCESS

Completion of engineering and design for the barge unloading facilities portion of Port Site 1 remains a priority to permit contractor mobilization and timely construction to coincide with the main access road completion. Port facilities construction will concentrate on the initial facilities required to support materials transshipment destined for the mine site. This includes sufficient additional camp space for logistics personnel, barge offloading equipment, diesel storage and transport equipment.

Construction of the pipelines will be staged after the access road is fully completed and can utilize some of the road construction camps.

Shipment of modules for the permanent mine site accommodation and services complex will be the first items to use the completed barge port and access road. Materials and equipment deliveries for the process plant, power plant and open pit mining will be scheduled after the accommodation/services complex at the mine site is completed.

#### 18.7.6 CONSTRUCTION CAMP

Initially, local accommodation at Iliamna will be utilized in the form of a 50-person camp. This would serve as project site headquarters until the mine site complex is established. The permanent accommodation and services complex at the mine site will be constructed as soon as the access road is completed to enable its use for the construction phase. All rooms will have private bathrooms and will be double occupancy for the construction phase of the project. On completion of the construction phase, the rooms will be refurbished and used as single rooms for the operational phase. The number of rooms required at the mine site permanent accommodation complex for the initial operational phase is 1,150. The number of camp beds required for the construction phase will depend on peak manpower loading. The permanent camp will be constructed for operational requirements, with peak construction manpower managed to keep below the double occupancy levels of the permanent camp and available temporary camps.

#### 18.7.7 MINE/MILL SITE CONSTRUCTION EXECUTION

##### OPEN PIT PRE-PRODUCTION

Initial development of the open pit will be conducted with the earthworks fleet that was used to construct the access road. Pre-production stripping of the waste to provide ore exposure will be done with electric shovels and 400 ton haul trucks once the power plant is on line and the pit is electrified. Initial work will be done using diesel powered shovels.

Pre-production pit activity will concentrate on clearing the overburden and soils off the first pit phase, constructing the haul roads and developing bench faces for the larger equipment. Other work done undertaken by the construction fleet will include site earthworks and initial tailings embankment

work. As production mine equipment is brought on stream, waste stripping will focus on supplying rock for the major tailings embankments construction.

Completion and commissioning of electrical power systems and the pit distribution network is a necessary predecessor for operation of the electric shovels and electric blast hole drills. A large diesel hydraulic shovel and diesel powered drill will allow earlier pit mining to start independent of the power generation and distribution system. This will also allow for initial training of personnel for mine operations.

#### CRUSHER INSTALLATION

Development and erection of two semi-mobile ore crushers and associated overland conveyors and material handling equipment will be carried out before mechanical completion of the process plant. The deliverables in this area of the mine site consist of:

- ore storage/reclaim structure;
- placement of semi-mobile ore crushers at the pit rim; and
- interconnecting overland conveyors and mechanical equipment.

On completion of the bulk earthworks program and after establishment of the permanent accommodation/services complex, work on the ore crushers will commence. The crushers will be operational in advance of the mill start-up. The crushing plants will be tested and commissioned using ore from the pit prior to mill start-up.

#### PROCESS PLANT

The process plant will be a large central structure housing the mills, flotation cells, several related ancillary structures, process systems and tankage.

Work in this area will begin with site grading undertaken by the earthworks fleet as part of initial site development. However, construction of the foundations and building/equipment installation will commence only after the accommodation/service complex is substantially completed. The central plant structure is split into the grinding and flotation sections because of the different character of the work in these areas. In general, work in both areas will start on the south foundation walls at the same time and proceed independently. Work on the flotation section will proceed from the perimeter foundations and under-slab work, to slab on grade, to the process equipment support steel and flotation cell/tank initial installation, to the structural steel and completion of the enclosing structure.

Mechanical completion, electrical work, piping and material transport installations will be scheduled as soon as major equipment components are set in place. Commissioning of the process plant will be done circuit by circuit with train 1 being fully commissioned once the permanent power plant is completed. All of the work culminates in a dedicated, functional checkout activity for each production line, which in turn culminates with an overall plant checkout leading to overall system commissioning.

Mechanical completion of the two process plant grinding circuit trains is staggered by several months. Completion of the first train requires full completion of the shared ancillary plant systems.

## TAILINGS STORAGE FACILITY (TSF)

The tailing storage facility (TSF) impoundment will be created with the construction of the Site G embankment using trenched excavation and rock fill derived from the mine pre-production stripping. Work on the tailings dam and trench will commence during the final years of site construction.

## PERMANENT POWER

Permanent power will be required to start open pit and process plant operations. The power plant will be commissioned early in the final year of the construction period. Turbine units will be brought on line as demand increases. The temporary diesel power station used to power the construction site and serve the accommodation/service complex will be supplanted by the natural gas-fired power station, but will remain as a backup emergency power for critical loads.

Natural gas is the fuel of choice. A pipeline will be constructed undersea Cook Inlet to the port site area, and will generally follow the access road corridor to the mine site. A pipe laying vessel will install the undersea portion of the pipeline.

The power plant is expected to be a turnkey design and supply package and may require tendering and engineering commitments prior to the notice to proceed date to ensure timely installation.

## CONSTRUCTION EQUIPMENT SUPPLY

The construction contractors will generally supply all equipment required for their respective construction activities.



## 18.8 FINANCIAL ANALYSIS

### 18.8.1 SUMMARY

The 45-year Reference Case yields a 14.2% pre-tax internal rate of return (IRR), a 6.2-year payback on \$4.7 billion capital investment and a \$6.13 billion pre-tax net present value (NPV) at a 7% discount rate.

**Table 18.8.1 Pebble Project Results – Summary**

Item	Unit	IDC Case	Reference Case	Resource Case
Mine Life	years	25	45	78
Mining Method		Open Pit	Open Pit	Open Pit
Pre-Tax* NPV at 0%	\$M	20,123	55,278	87,329
Pre-Tax* NPV at 5%	\$M	6,363	11,163	12,941
<b>Pre-Tax* NPV at 7%</b>	<b>\$M</b>	<b>3,837</b>	<b>6,129</b>	<b>6,812</b>
Pre-Tax* NPV at 8%	\$M	2,901	4,510	4,964
Pre-Tax* NPV at 10%	\$M	1,485	2,308	2,545
Pre-Tax* IRR	%	13.4	14.2	14.5
Payback	years	6.5	6.2	6.1
Initial Capital	\$M	4,695	4,695	4,695
NSR Per Ton Milled	\$/ton	27.45	31.91	32.78
Operating Cost Per Ton	\$/ton	11.16	11.55	14.72
C1 Copper Cost**	\$/lb	-0.10	-0.11	0.21
Production Rate	M ton/year	80	84	84
Strip Ratio	waste : ore	1.5	2.1	2.6
Total Processed	M ton	1,990	3,767	6,528
% of M+I+I Resource	%	17	32	55
Copper Recovery	%	86.6	87.9	88.4
Gold Recovery	%	71.5	71.3	71.2
Molybdenum Recovery	%	84.8	87.9	89.4
Copper Eq. Grade	%	0.72	0.83	0.84
Copper Grade	%	0.38	0.46	0.46
Gold Grade	oz/ton	0.012	0.011	0.011
Molybdenum Grade	ppm	182	214	243
Copper Eq. Recovered	Mlb	24,483	54,129	96,357
Total Copper Recovered	Mlb	12,944	30,494	53,437
Total Gold Recovered	k oz	16,391	30,307	50,133
Total Molybdenum Recovered	Mlb	616	1,420	2,835
Peak Copper Recovered	Mlb	822	1,157	1,096
Peak Annual Gold Recovered	k oz	1,038	1,127	1,088
Peak Molybdenum Recovered	Mlb	43	56	62
Avg. Annual Copper Recovered	Mlb	518	678	685
Avg. Annual Gold Recovered	k oz	656	673	643
Avg. Annual Mo Recovered	Mlb	25	32	36
26% Cu Concentrate Produced	k DMT	22,582	53,200	93,225
52% Mo Concentrate Produced	k DMT	537	1,239	2,473

Notes: \* Pre-tax results are before income taxes but after NPI royalty and local production taxes

\*\*C1 Copper Cost is Copper Cash Cost after by-product credits at long-term metal prices

Wardrop has prepared an economic valuation of the project as reported in this Financial Analysis section based on a series of successive financial models. All amounts expressed in this section of the Preliminary Assessment are in US dollars in real terms.

The valuation date on which the NPV and IRR and other financial results are measured is at commencement of construction (annotated as Year -4 of the project with mining commencing in Year -1 and production commencing in Year 1). Cash flows are discounted back to Year -4 using a mid-year convention.

## METAL PRICES

The long-term metal prices shown in Table 18.8.2 are applied throughout each of the financial models.

**Table 18.8.2 Long-term Metal Prices**

Metal Type	Unit	\$
Copper	lb	2.50
Gold	oz	1,050
Molybdenum	lb	13.50
Silver	oz	15.00
Rhenium	kg	3,000
Palladium	oz	490

These long-term metal prices are consistent with the mean consensus forecast from the Energy Metals Consensus Forecast (EMCF). The mean EMCF quarterly long-term consensus metal prices as of the date of this PA were \$2.66/lb for copper, \$1,058/oz for gold, \$16.57/lb for molybdenum and \$16.57/oz for silver. The EMCF is published by Consensus Economics Inc. (Consensus Economics) of London. Consensus Economics provides a quarterly forecast (the EMCF) for a variety of metals based on a selection of analysts. The EMCF averages 20 or 30 projections in a single average (consensus) forecast.

The ‘upper limit’ EMCF quarterly long-term consensus metal prices as of the date of this PA, defined as within one standard deviation from the mean EMCF long-term consensus price were \$3.01/lb of copper, \$1,221/oz for gold, \$19.95 for molybdenum and \$19.73 for silver. Financial results under each development case would notably increase if these ‘upper limit’ EMCF quarterly long-term consensus metal prices were used as the basis of the financial evaluation of the Pebble Project and Northern Dynasty. Financial outcomes as a result of differing metal prices assumptions are illustrated in the sensitivity section for each development case.

In certain instances in this section, where indicated, financial results are shown based on current prevailing metal prices. Current prevailing metal prices for this purpose are shown in Table 18.8.3.

**Table 18.8.3 Current Prevailing Metal Prices**

Metal Type	Unit	\$
Copper	lb	4.00
Gold	oz	1,350
Molybdenum	lb	15.00
Silver	oz	28.00
Rhenium	kg	3,000
Palladium	oz	490

At current prevailing metal prices, the 45-year Reference Case yields a 23.2% pre-tax IRR a 3.2-year payback and a \$15.71 billion pre-tax NPV at a 7% discount rate.

**Table 18.8.4 Pebble Project Financial Results – Current Prevailing Metal Prices**

Item	Unit	IDC Case	Reference Case	Resource Case
Mine Life	years	25	45	78
Mining Method		Open Pit	Open Pit	Open Pit
<b>Financial Results</b>				
Pre-Tax NPV at 0%	\$M	42,952	105,877	175,060
Pre-Tax NPV at 5%	\$M	16,411	25,309	28,689
<b>Pre-Tax NPV at 7%</b>	<b>\$M</b>	<b>11,410</b>	<b>15,709</b>	<b>16,864</b>
Pre-Tax NPV at 8%	\$M	9,535	12,563	13,268
Pre-Tax NPV at 10%	\$M	6,659	8,210	8,506
Pre-Tax IRR	%	22.6	23.2	23.3
Payback	years	3.2	3.2	3.2

#### DISCOUNT RATE

Annual cash flows are calculated and subsequently discounted at a rate of 7%. Market convention generally uses a discount rate of 8% for copper and base metal projects and 5% for gold and precious metal projects. Given the large contribution of gold to total metal value at the Pebble Project, the 7% discount rate has been selected by Wardrop and is considered an appropriate blended rate for discounting the Pebble Project cash flows for discounted cash flow analysis purposes.

#### SUCCESSIVE DEVELOPMENT CASES CONSIDERED

Three successive mine development cases have been presented in the Preliminary Assessment to evaluate the Pebble Project based on a notional 200,000 ton per day milling capacity. All three cases have been evaluated using the long-term metal prices listed above. *It should be noted that Inferred mineral resources are considered to be too speculative to allow the application of technical and economic parameters to support mine planning and the evaluation of the economic viability of the project. As such, there is currently no certainty that development cases incorporating Inferred mineral resources can be realized.*

The following is an overview of each development case.

**1. The 25-Year IDC Case**

- The 25-year IDC Case describes an initial 25-year open pit mine life upon which a decision to initiate mine permitting, construction and operations may be based. Of the three development cases, the 25-year IDC Case is the most comprehensively engineered. It seeks to mine near-surface ore for rapid payback, primarily in Measured and Indicated categories but also including a small proportion of Inferred material in the western portion of the Pebble deposit. Inferred resources comprise 16% of total ore mined. This initial phase of mining will process about two billion tons of ore or less than 20% of the total Pebble mineral resource. As such, it is not considered to be ideal for assessing the long-term economic value of the project.

**2. The 45-Year Reference Case**

- The 45-year Reference Case is based on 45 years of open pit mine production and will require separate permitting and development decisions to be made in the future, based on prevailing conditions at the time and the accumulated experience gained from developing and operating the initial phase of the Pebble Project. The level of engineering applied to the 45-year Reference Case is similar to that in the 25-year IDC Case, with the exception of detailed engineering associated with tailings storage after Year 25. This extended phase of mining will process a total of some 3.8 billion tons of ore (or 32% of the total Pebble mineral resource), primarily in Measured and Indicated categories in the western portion of the deposit. Inferred resources in the eastern portion of the deposit comprise 28% of the total ore mined.

**3. The 78-Year Resource Case**

- The 78-year Resource Case is based on 78 years of open pit mine production and seeks to assess the longer term value of the project in current dollars. The 78-year Resource Case will also require separate permitting and development decisions to be made in the future, based on prevailing conditions at the time and the accumulated experience gained from developing and operating the initial phase of the Pebble Project. The 78-year Resource Case is based on a continuation of mining methods, costs and assumptions that inform the 25-year IDC Case and the 45-year Reference Case. By developing some 55% of the Pebble mineral resource over eight decades, it is intended to demonstrate the longer-term economic value of the Pebble Project. The 78-year Resource Case will process a total of some 6.5 billion tons of ore, primarily in Measured and Indicated categories from both the western and eastern portions of the Pebble deposit. Inferred resources comprise 33% of the total ore mined.

Wardrop has selected the 45-year Reference Case as the base case for this Preliminary Assessment due to its enhanced level of development of the Pebble mineral resource within a timeframe that makes a significant contribution to the project's NPV.



## PROJECT PLANNING ALTERNATIVES

The development cases presented in this Preliminary Assessment are based upon recent engineering and project design work conducted by the Pebble Partnership and Northern Dynasty. The Pebble Partnership continues to advance project planning initiatives as it works toward the completion of a Prefeasibility Study for the Pebble Project, including efforts to engage project stakeholders in the planning process. As such, the project description that the Pebble Partnership ultimately elects to submit for permitting under NEPA is likely to differ from the development cases presented in this document.

While it's certain that near-surface mineral resources within the western portion of the Pebble deposit will be most efficiently developed through open pit methods, underground mining (in particular, block caving) remains a viable option for developing the deeper and higher-grade resources in the eastern portion. Each of the three development cases described in this Preliminary Assessment employ open pit mining methodologies only. However, it is expected that additional underground investigations will be undertaken during the initial 25 years of production.

Initial economic analysis has indicated that underground block caving is economically viable for the eastern portion of the deposit. While the economic evaluation of all three development cases presented in this Preliminary Assessment is based on open pit mining only, the potential remains for underground block caving to emerge as the preferred mining method for subsequent phases of development at Pebble.

Phases of development beyond 25 years will require separate permitting and development decisions to be made in the future, based on prevailing conditions at the time and the accumulated experience gained from developing and operating the initial phase of the Pebble Project.

## NORTHERN DYNASTY ALLOCATION

Under the terms of the Pebble Limited Partnership Agreement, Anglo American is required to elect to commit \$1.425 to \$1.5 billion in staged investments in order to retain its 50% interest in the Pebble Project. If a feasibility study for the Pebble Project is completed after 2011, Anglo American's overall funding requirement increases from \$1.425 billion to \$1.5 billion. A significant proportion of this earn-in contribution is expected to be applied to initial capital costs to construct the mine, thereby reducing Northern Dynasty's capital requirement to maintain its 50% interest in the project.

In order to calculate an NPV and IRR estimate for Northern Dynasty's 50% interest in the Pebble Project under this earn-in arrangement, it is necessary to adjust Northern Dynasty's share of initial capital costs. For the purpose of this calculation, it is assumed that \$1 billion of Anglo American's current funding commitment will be applied to the Pebble Project's capital cost for construction.

Based on the same financial inputs and considerations described in the 'Pebble Project Results – Summary' section above, as well as Northern Dynasty's reduced capital requirements, the economic valuation of Northern Dynasty's interest in each of the three development cases are summarized in Table 18.8.5. Inasmuch as Northern Dynasty is in a position to calculate taxes payable for its portion of profits associated with development of the Pebble Project, financial results for Northern Dynasty's 50% interest in the project have been presented on a pre-tax and post-tax basis.

**Table 18.8.5 Northern Dynasty Financial Results at Long-term Metal Prices**

Item	Unit	IDC Case	Reference Case	Resource Case
Pre-Tax NPV at 0%	\$M	10,561	28,139	44,165
Pre-Tax NPV at 5%	\$M	3,671	6,071	6,960
<b>Pre-Tax NPV at 7%</b>	<b>\$M</b>	<b>2,403</b>	<b>3,550</b>	<b>3,891</b>
Pre-Tax NPV at 8%	\$M	1,933	2,738	2,965
Pre-Tax NPV at 10%	\$M	1,222	1,633	1,751
Pre-Tax IRR	%	17.3	18.0	18.4
Payback	years	4.9	4.7	4.6
Post-Tax NPV at 0%	\$M	7,532	19,818	31,583
Post-Tax NPV at 5%	\$M	2,491	4,164	4,877
<b>Post-Tax NPV at 7%</b>	<b>\$M</b>	<b>1,559</b>	<b>2,358</b>	<b>2,650</b>
Post-Tax NPV at 8%	\$M	1,213	1,774	1,975
Post-Tax NPV at 10%	\$M	689	976	1,087
Post-Tax IRR	%	14.6	15.4	15.8
Payback	years	5.6	5.3	5.3

Northern Dynasty's financial results at current prevailing metal prices are outlined in Table 18.8.6.

**Table 18.8.6 Northern Dynasty Financial Results at Current Prevailing Metal Prices**

Item	Unit	IDC Case	Reference Case	Resource Case
Pre-Tax NPV at 0%	\$M	21,976	53,439	88,030
Pre-Tax NPV at 5%	\$M	8,695	13,144	14,834
<b>Pre-Tax NPV at 7%</b>	<b>\$M</b>	<b>6,190</b>	<b>8,339</b>	<b>8,917</b>
Pre-Tax NPV at 8%	\$M	5,250	6,765	7,117
Pre-Tax NPV at 10%	\$M	3,808	4,584	4,732
Pre-Tax IRR	%	29.5	30.2	30.4
Payback	years	2.7	2.6	2.6
Post-Tax NPV at 0%	\$M	15,120	35,881	60,121
Post-Tax NPV at 5%	\$M	5,891	8,830	10,065
<b>Post-Tax NPV at 7%</b>	<b>\$M</b>	<b>4,141</b>	<b>5,561</b>	<b>6,002</b>
Post-Tax NPV at 8%	\$M	3,483	4,483	4,761
Post-Tax NPV at 10%	\$M	2,471	2,983	3,108
Post-Tax IRR	%	24.5	25.1	25.4
Payback	years	3.1	3.1	3.0

## 18.8.2 BASIS FOR ANALYSIS

This section outlines the basis for the financial analysis that is common to all three development cases presented in this Preliminary Assessment.

## DISCOUNTED CASH FLOW ANALYSIS

Production statistics from each development case have been incorporated into the financial model to develop annual recovered metal production from the relationships of tonnage milled, head grades and recoveries. Market prices for copper, gold, molybdenum, silver and palladium have been adjusted to realized price levels by applying smelting, refining, and concentrate transportation charges from mine site to smelter to determine the net smelter return (NSR) contributions for each metal.

Fixed and variable operating costs for open pit, tailings, process, general and administrative, environmental, and transportation areas have been applied to annual milled tonnages to determine the overall mine site operating cost that has been deducted from NSRs to derive annual Net Revenues.

Initial and sustaining capital costs have been incorporated on a year-by-year basis over the mine life and deducted from the Net Revenue to determine Net Cash Flow before taxes.

## FISCAL REGIME

The proposed mine is located in the state of Alaska in the United States of America, and is thus bound by the fiscal regime of that state and country.

Given its location in the US, the Pebble Project benefits from being in a top-tier Western country with one of the world's most advanced systems of mining, environmental and commercial laws. The US is also one of the world's leading mining nations, producing a wide variety of core commodities and minerals. It is a significant global producer of gold, copper, silver, lead, zinc, molybdenum, and coal.

The State of Alaska is a progressive jurisdiction that offers stable and predictable regulatory oversight, an exemplary tradition of hard rock mining and broad public support for resource development. The State Constitution explicitly allows for the development of the state's resources in the best interests of its people.

In contrast to many other Alaskan mining projects, the Pebble deposit is not located on either federal lands or lands owned by Alaska Native Corporations. Rather, the Pebble deposit is located on state land that has been specifically selected by the state for its mineral potential. Pebble is also included in one of five land parcels within the Bristol Bay Area Plan (BBAP) that is intended to accommodate mineral exploration and development.

## TAXES AND ROYALTIES

### *Pebble Partnership*

In 2007, Northern Dynasty and Anglo American formed a limited partnership to advance the Pebble Project. As a partnership is not a taxable entity for US tax purposes, tax liabilities accrue to each partner based on its proportionate share of the income from the project in a fiscal period.

For the purposes of calculating economic valuation results on a post-tax basis for Pebble, this Preliminary Assessment financial evaluation has assumed that the Pebble Project will be subject to tax as if the Pebble Project has been held 100% by a US corporate resident entity. This approach has been taken to facilitate comparison of Pebble to other mining projects that are owned on a 100% basis.

## Taxes

Profit from sale of concentrate produced at Pebble will be subject to taxation by multiple levels of government. Given that Pebble is one of the world's most important undeveloped copper-gold deposits, tax revenues derived from mining operations will contribute significantly to US federal, state and local governments for decades.

At long-term metal prices, total estimated taxes payable on Pebble profits in real terms are:

- \$8.9 billion over a 25 year mine life;
- \$23.3 billion over a 45 year mine life; and
- \$32.9 billion over a 78 year mine life.

At current prevailing metal prices, total estimated taxes payable on Pebble profits in real terms are:

- \$18.1 billion over a 25 year mine life;
- \$45.8 billion over a 45 year mine life; and
- \$70.6 billion over a 78 year mine life.

Details of the breakdown of the project's estimated tax payments (assuming 100% corporate ownership) at long-term metal prices are outlined under each of the three development cases in Table 18.8.7. These figures only include tax liabilities directly payable on project profits (assuming a corporate entity holds 100% of the Pebble Project) and do not include other indirect taxes that would be created by the project (i.e. taxes payable by subcontractors and individuals directly or indirectly employed by Pebble), which would also be substantial contributors to federal, state and local governments.

**Table 18.8.7 Estimated Pebble Project Taxes – Long-term Metal Prices**

Item	Unit	IDC Case	Reference Case	Resource Case
Total Federal Corporate Income Tax	\$M	4,313	11,882	18,125
Total State of Alaska Taxes	\$M	3,869	9,922	12,700
Municipal Severance and Property Tax	\$M	695	1,541	2,088
<b>Total Taxes</b>	<b>\$M</b>	<b>8,877</b>	<b>23,345</b>	<b>32,913</b>

Estimated Pebble Project taxes at current prevailing metal prices under each development case are outlined in Table 18.8.8.

**Table 18.8.8 Estimated Pebble Project Taxes at Current Prevailing Metal Prices**

Item	Unit	IDC Case	Reference Case	Resource Case
Total Federal Corporate Income Tax	\$M	9,527	25,166	40,030
Total State of Alaska Taxes	\$M	7,507	18,209	27,004
Municipal Severance and Property Tax	\$M	1,073	2,393	3,564
<b>Total Taxes</b>	<b>\$M</b>	<b>18,107</b>	<b>45,768</b>	<b>70,598</b>

Post-tax financial results for the Pebble Project assuming a US corporate entity would hold 100% of the Pebble Project are shown in Table 18.8.9 at both long-term and current prevailing metal prices.

**Table 18.8.9 Pebble Project Post-tax Financial Results – All Cases**

Item	Unit	IDC Case	Reference Case	Resource Case
<b>Long-term Metal Prices</b>				
Post-Tax NPV at 0%	\$M	14,824	40,214	64,328
Post-Tax NPV at 5%	\$M	4,407	7,857	9,318
<b>Post-Tax NPV at 7%</b>	<b>\$M</b>	<b>2,475</b>	<b>4,121</b>	<b>4,721</b>
Post-Tax NPV at 8%	\$M	1,756	2,912	3,325
Post-Tax NPV at 10%	\$M	665	1,257	1,485
Post-Tax IRR	%	11.7	12.6	12.9
Payback	years	6.9	6.6	6.4
<b>Current Prevailing Metal Prices</b>				
Post-Tax NPV at 0%	\$M	30,706	73,606	123,473
Post-Tax NPV at 5%	\$M	11,554	17,629	20,167
<b>Post-Tax NPV at 7%</b>	<b>\$M</b>	<b>7,910</b>	<b>10,846</b>	<b>11,753</b>
Post-Tax NPV at 8%	\$M	6,537	8,607	9,177
Post-Tax NPV at 10%	\$M	4,425	5,487	5,743
Post-Tax IRR	%	19.7	20.2	20.3
Payback	years	3.6	3.5	3.5

The following summary describes the significant taxes (categorized between Production and Income) applicable to the Pebble Project.

*Production Taxes*

Both the state and municipal governments in Alaska collect taxes relating to mineral production. State taxes include a mining licence tax and an Alaska state royalty. The State of Alaska has no state sales tax.

The Alaska state royalty (on Alaska state lands) is calculated at 3% of net income from mining operations while the mining licence tax is assessed on net income from mineral product sales. Legislation allows for a 3.5-year hiatus from this mining licence tax after the commencement of initial production. The maximum mining licence rate is 7% on net income over \$100,000.

Municipal (Borough) governments in the State of Alaska assess property, sales and use and/or severance taxes. The Lake and Peninsula Borough, in which the project is located, has enacted a municipal severance tax of 1.5% of net income from mineral product sales and this tax has been applied.

There is no provision in the legislation to carry losses forward to offset future profits in the state royalty, mining licence or severance tax calculation.

### Income Taxes

For US federal income tax purposes, in accordance with the Internal Revenue Code (IRC), a taxpayer is required to calculate taxes under both the regular corporate tax system and the Alternative Minimum Tax (AMT) system and pay whichever method results in the higher amount of taxes.

The statutory US federal income tax rate is 35% and the tax rate under AMT is 20%. The maximum Alaska state income tax rate is 9.4%. As state taxes are deductible for federal purposes, the combined statutory income tax rate for the Pebble Project will be 41.1% of taxable income.

Taxable losses generated in a given year may be carried forward for 20 years and applied to taxable income when it arises, or carried back two years and applied against taxable income from the project in those years. The IRC also provides certain deductions to incentivize investment by mining companies, including depletion and development expenditures.

The benefits of depletion and other deductions under the IRC for Pebble reduces the average mine life effective income tax rate from the combined statutory tax rate of 41.1% to the effective income tax rates shown in Table 18.8.10 for each scenario.

**Table 18.8.10 Effective Income Tax Rates**

Item	Unit	IDC Case	Reference Case	Resource Case
Effective Income Tax Rate	%	26.3	27.3	26.3

### Royalties

A portion of the Pebble deposit is subject to a 4% pre-payback net profits interest (after debt service) increasing to a 5% after-payback net profits interest. This royalty would be owed by the Pebble Partnership to Teck Resources. This royalty arose from Northern Dynasty's acquisition of the Exploration Lands (the lands other than the Resource Lands which hosts Pebble West) from a predecessor company to Teck Resources.

### MARKETS AND CONTRACTS

Given its location in southwest Alaska, Pebble is strategically located for delivery to Asian custom smelters. A mine of Pebble's size coming into production during this decade with its ability to offer long-term supply to a smelter should have little difficulty in placing 1.1 million tonnes per year of copper concentrate production from its initial years of operation. The continued growth from Asia and other parts of the developing world should address any longer term concentrate demand concerns.

At 26% Cu and over 15 grams Au with low impurity levels, the Pebble concentrate will be viewed favourably by the existing market place. The improving precious metals prices over the past year will dictate assessment of alternate recovery strategies during the next phase of study. One of these may be to reduce the copper concentrate grade to increase gold recovery. Given the current surplus of smelter capacity primarily domiciled in China and India, the Pebble Partnership is not expected to face any difficulties marketing a lower grade concentrate (assuming similar gold levels and with no material increase in impurity levels), if desired, to further enhance revenue.

An off-shore autoclave processing plant costing \$374 million is included in all three development cases. This will ensure Pebble receives optimum value for its molybdenum concentrate. Further, testwork has demonstrated the Pebble molybdenum concentrate contains elevated levels of rhenium and the inclusion of the autoclave in the project will ensure enhanced recovery, and payment, for this product.

Another option for the molybdenum concentrate would be for Pebble to look to a long-term roasting agreement. The duration of such an agreement could be as short as five years or as long as 10 years. Processing capacity should be available to manage a long-term roasting agreement for Pebble, but capture of full value for rhenium may not be possible under this option.

### SMELTER TERMS

Smelter terms used in the financial model have been provided by Northern Dynasty. The long-term values included in the model are shown in Table 18.8.11 and Table 18.8.12.

**Table 18.8.11 Smelter Terms**

Item	Unit	Terms
Copper Treatment Charges	\$/DMT	70.00
Copper Refining Charges	c/lb	7.0
Copper Deduction	% of concentrate	1.0
Gold Refining Charges	\$/oz	5.00
Gold Deduction	% of production	3.0
Silver Refining Charges	\$/oz	0.40
Silver Deduction	% of production	10.0
Palladium Deduction	g/t of production	0.12

**Table 18.8.12 Doré Terms**

Item	Unit	Terms
Gold Deduction	% of Production	0.50
Silver Deduction	% of Production	1.50

Price participation has not been included in the financial analysis. There is a possibility that, if a period of significant concentrate oversupply is created in the future, smelters may re-introduce price participation.

### CONCENTRATE TRANSPORT LOGISTICS

Copper concentrate will be transported from the mine site to the port site via a pipeline. At the port site, the dewatered concentrate will be stored in a load-out facility, from which it will be reclaimed for direct loading of concentrate bulk vessels, for shipping to smelter customers in the Far East and potentially Europe. Ocean transportation costs are estimated at \$50.00/wmt and assume concentrate moisture content of 7.5%.

The molybdenum concentrate will be dried at the mine site, placed in bulk bags; and stored in 20 foot shipping containers. These will be backhauled to the port and loaded onto vessels for shipping to the proposed molybdenum refinery.

An insurance rate of 0.02% will be applied to the provisional invoice value of the copper concentrate to cover land-based and ocean transport from the mine site to the smelter.

#### METALLURGICAL RECOVERIES

Metallurgical recoveries are based on the mined grade and ore type shown in the mining plans and are incorporated into the financial model annually for the open pit.

#### HEAD GRADES

The head grades for each development case have been estimated for each year from resource models within the production forecast prepared for each development case.

#### WORKING CAPITAL

An allowance has been made in the financial model for working capital. Debtor and creditor days have been assumed at 45 days with an inventory investment equal to 5% of costs. Total working capital at the end of year 1 for all three development cases is equal to \$108 million.

#### INITIAL CAPITAL

The estimated initial capital cost to design, construct, and commission the Pebble Project is \$5,757 million including contingency, in second quarter 2009 US dollars. The cost escalation/de-escalation to current dollars resulted in a net decrease in capital costs of \$121 million. The capital cost of the primary infrastructure to be provided by third parties, including power generation, port facilities and access road, has been estimated to be \$1,315 million. The capital cost of the molybdenum refinery has been estimated to be \$374 million. Thus, the initial capital cost incorporated into the financial model is \$4,695 million.

Table 18.8.13 shows the composition of total initial capital used for financial modelling purposes.



**Table 18.8.13 Pebble Project – Initial Capital – All Cases**

Area	Capital Cost (\$ M)
Mining	430.8
Process	1,058.2
Molybdenum Separation	83.5
Secondary Gold Plant	160.5
Infrastructure	422.0
Tailings	294.0
Pipelines	97.5
Access Road *	162.0
Port infrastructure *	154.5
Port process	87.1
Power generation *	534.1
Indirect costs	1,406.8
Contingency	865.7
<b>Total Capital Cost Estimate</b>	<b>5,756.7</b>
Molybdenum Autoclave	374.2
Less: Escalation/De-escalation Adjustments	(121.1)
Less: Outsourced Infrastructure *	(1,315.0)
<b>Initial Capital – Financial Model</b>	<b>4,694.8</b>

Note: (\*) Outsourced infrastructure, including associated indirects and contingencies.

#### OUTSOURCING OF INFRASTRUCTURE ASSETS

All three development cases presented in this Preliminary Assessment assume that Pebble will enter into strategic partnerships as needed to develop, finance and operate a number of infrastructure assets. These infrastructure assets include the transportation corridor (port & road) and the power plant. The breakdown of these outsourced assets is shown in Table 18.8.14.

**Table 18.8.14 Capital Cost Breakdown of Outsourced Infrastructure Assets**

Area	Cost (\$M)
Power	828
Port	243
Road	244
<b>Total</b>	<b>1,315</b>

Pebble has forged strong relationships with a number of Alaska Native Village Corporations in the project area through existing business-partnering initiatives. Continuing to foster relationships through financial partnering with local Alaska Native communities, Alaska Native Village Corporations and the larger Alaska Regional Native Corporations, will be important to the long-term success of the Pebble Project. In some cases, additional partners with operational expertise may be sought to work alongside Alaska Native Corporations. These partners could include an Alaskan utility (including a newly formed/consolidated utility), an independent power producer, a special purpose financing

vehicle or strategic international financial investors. There are also other financing precedents that could be brought forward, most notably for the transportation corridor.

#### MOLYBDENUM AUTOCLAVE

Each development case assumes that Pebble will construct a molybdenum autoclave plant offshore to treat the molybdenum concentrate and receive enhanced benefits through improved pricing with rhenium and additional copper value recovery (Table 18.8.15).

**Table 18.8.15 Molybdenum Autoclave Specifications**

Description	Unit	Value
Autoclave Capacity	tpa	25,000,000
Autoclave Recovery Improvement	%	3
Rhenium Recovery	%	85
Selenium Recovery	%	85
Copper Recovery	%	85
Rhenium Content	ppm	1,100
Selenium Content	ppm	500
Copper Content	%	1.80
TGMo Split	%	80
FeMo Split	%	20
CGMo Growth	%	8
CGMo Premium	\$/lb	1.50
TGMo Premium	\$/lb	0.03
FeMo Premium	\$/lb	0.27
Selenium Price	\$/lb	20.00
Selenium Refining Cost	\$/lb	10.00
Copper Refining Cost	\$/lb	0.25
Freight to Customers	\$/lb	0.08

#### SALVAGE VALUE

There is no salvage value included in the financial evaluation.

#### RECLAMATION AND CLOSURE COSTS

Both the Alaska Department of Natural Resources (DNR) and the Alaska Department of Environmental Conservation (DEC) require that sufficient financial surety be set aside at the beginning of five year increments to cover closure costs if the mine should close prematurely. Closure cost obligations will be reviewed every five years by the State of Alaska, and the sufficiency of the financial surety set aside will be reviewed and updated accordingly.

For financial evaluation purposes, it is assumed that the Pebble Partnership will provide equal payments over the estimated mine life under each development case and that any shortfall between the accumulated funds within the reclamation trust and the reclamation liability will be made whole

with financial assurance in the form of a letter of credit. Funds contributed to the reclamation trust are assumed to earn a real return of 4.3%.

**18.8.3 45-YEAR REFERENCE CASE MINE PLAN**

The 45-year Reference Case is based on 45 years of open pit mine production and will require separate permitting and development decisions to be made in the future, based on prevailing conditions at the time and the accumulated experience gained from developing and operating the initial phase of the Pebble Project. The level of engineering applied to the 45-year Reference Case is similar to that in the 25-year IDC Case, with the exception of detailed engineering associated with tailings storage after Year 25.

The 45-year Reference Case achieves a pre-tax NPV of \$6.13 billion using a discounted cash flow approach to valuation. It achieves a pre-tax IRR of 14.2% and a payback period of 6.2 years. The 45-Year Reference Case produces 30.5 Blb of copper, 30.3 Moz of gold and 1.4 Blb of molybdenum. Copper production is at a total cash cost of \$-0.11/lb after revenue credits from gold and other metals.

The 45-year Reference Case will process a total of some 3.8 billion tons of ore, primarily in Measured and Indicated categories in the western portion of the deposit. Inferred resources in the eastern portion of the deposit comprise 28% of the total ore mined.

It should be noted that Inferred mineral resources are considered to be too speculative to allow the application of technical and economic parameters to support mine planning and the evaluation of the economic viability of the project. As such, there is currently no certainty that development cases incorporating Inferred mineral resources can be realized.

**PROJECT RESULTS**

Table 18.8.16 shows the key outputs from the financial model for the 45-year Reference Case. All dollar values are in real terms.

**CONCENTRATE PRODUCTION STATISTICS**

The 45-year Reference Case production statistics for copper-gold concentrate, including copper and gold metal, and molybdenum concentrate are illustrated in Table 18.8.17 and Figure 18.8.1.

**Table 18.8.16 Project Results – 45-Year Reference Case**

Item	Unit	
<b>Production Results</b>		
Tons Mined	M ton	11,574
Strip Ratio	waste:ore	2.1
Tons Milled	M ton	3,767
Copper Equivalent Grade	%	0.83
Copper Grade	%	0.46
Gold Grade	oz/ton	0.011

*Table continues...*

...Table 18.8.16 (cont'd)

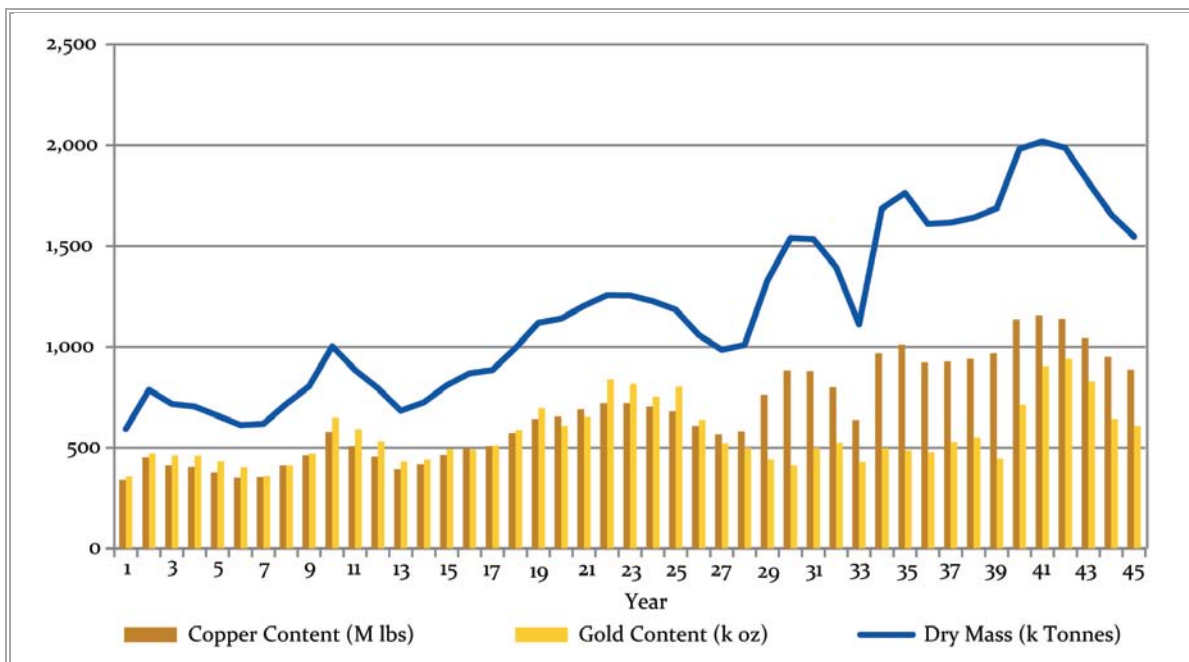
Item	Unit		
Molybdenum Grade	ppm	214	
Copper Recovery	%	87.9	
Gold Recovery	%	71.3	
Molybdenum Recovery	%	87.9	
<b>Total Production – LOM Total</b>			
Copper Equivalent	Mlb	54,129	
Copper	Mlb	30,494	
Gold	k oz	30,307	
Molybdenum	Mlb	1,420	
Silver	k oz	140,423	
Rhenium	k kg	1,158	
Palladium	k oz	907	
<b>Annual Production</b>		<b>Average</b>	<b>Peak</b>
Copper Equivalent	Mlb	1,203	2,046
Copper	Mlb	678	1,157
Gold	k oz	673	1,127
Molybdenum	Mlb	32	56
Silver	k oz	3,121	6,229
Rhenium	k kg	26	46
Palladium	k oz	20	34
<b>Financial Results</b>		<b>Pre-Tax</b>	<b>Post-Tax</b>
Pre-Tax NPV at 0%	\$M	55,278	40,214
Pre-Tax NPV at 5%	\$M	11,163	7,857
<b>Pre-Tax NPV at 7%</b>	<b>\$M</b>	<b>6,129</b>	<b>4,121</b>
Pre-Tax NPV at 8%	\$M	4,510	2,912
Pre-Tax NPV at 10%	\$M	2,308	1,257
Pre-Tax IRR	%	14.2	12.6
Payback	years	6.2	6.6
Initial Capital	\$M	4,695	
LOM Sustaining Capital	\$M	6,140	
<b>Net Smelter Return</b>			
Total	\$M	120,197	
Annual Average	\$M	2,671	
Copper	%	55	
Gold	%	24	
Molybdenum	%	16	
NSR Per Ton Milled	\$/ton	31.91	
<b>Operating and Cash Costs</b>			
Total	\$M	43,489	
Annual Average	\$M	966	
Operating Cost Per Ton Milled	\$/ton	11.55	
Copper Cash Cost	\$/ lb	1.86	
C1 Copper Cost*	\$/ lb	-0.11	

\* C1 Copper Cost is Copper Cash Cost after by-product credits at long-term metal prices

**Table 18.8.17 Concentrate Statistics – 45-Year Reference Case**

Description	Unit	Value
<b>Copper-Gold Concentrate</b>		
Cu-Au Concentrate Produced	k DMT	53,200
Copper Grade	% Cu	26.0
Gold Grade	g/DMT	15.9
Silver Grade	g/DMT	71.8
Palladium Grade	g/DMT	0.53
Concentrate Moisture Content	%	7.5
<b>Molybdenum Concentrate</b>		
Mo Concentrate Produced	k DMT	1,239
Molybdenum Grade	% Mo	52.0
Rhenium Grade	ppm	1,100
Concentrate Moisture Content	%	7.5

**Figure 18.8.1 Copper-Gold Concentrate Produced – 45-Year Reference Case**



## SUSTAINING CAPITAL

The 45-year Reference Case sustaining capital breakdown is shown in Table 18.8.18.

**Table 18.8.18 Sustaining Capital Costs – 45-Year Reference Case**

Area	Cost (\$M)	Cost (\$M/yr)
Open Pit	3,286	73.0
Processing	230	5.1
Infrastructure	165	3.7
Waste Management	2,211	49.1
Other	104	2.3
Molybdenum Autoclave	144	3.2
<b>Total</b>	<b>6,140</b>	<b>136.4</b>

## OPERATING COSTS

Fixed and variable operating costs for open pit, tailings, process, general and administration (G&A), environmental and transportation areas have been derived by each discipline and applied annually to the mine plan tonnage. Table 18.8.19 lists total operating costs for the 45-year Reference Case.

**Table 18.8.19 Total Operating Costs – 45-Year Reference Case**

Area	Cost (\$M)	Cost (\$/ton milled)
Open Pit	16,211	4.30
Process	17,328	4.60
Transportation	3,424	0.92
Environmental	1,107	0.29
G&A	5,419	1.44
<b>Total</b>	<b>43,489</b>	<b>11.55</b>

## OFFSITE CHARGES

Offsite charges for metal treatment and refinement, freight and insurance have been calculated annually and are listed in Table 18.8.20 for the 45-year Reference Case.

**Table 18.8.20 Offsite Charges – 45-Year Reference Case**

Area	Cost (\$M)	Cost (\$/ton milled)
Cu Treatment	5,777	1.53
Mo Treatment	140	0.04
Au Treatment	2,087	0.55
Ag Treatment	123	0.03
Freight and Insurance	2,942	0.79
<b>Total</b>	<b>11,089</b>	<b>2.94</b>

**CASH COST ANALYSIS**

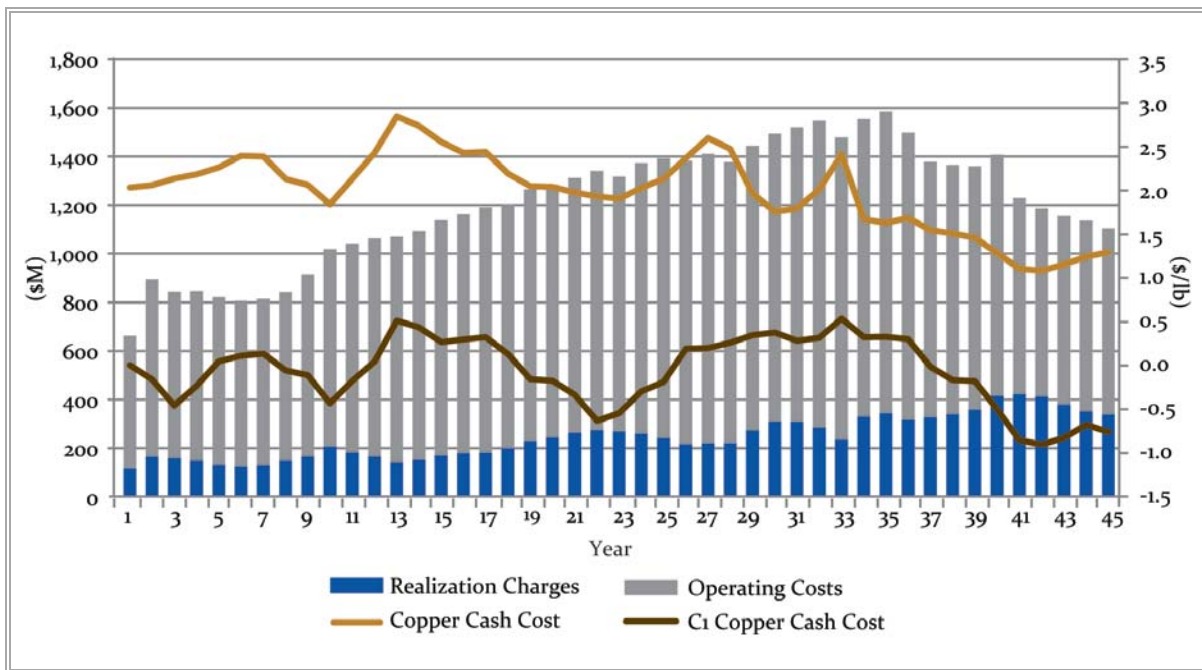
The life-of-mine copper cash cost for the 45-year Reference Case is \$1.86 per pound of copper payable (not including by-product credits but including total realization and operating costs for the project) and a C1 copper cash cost estimated at -\$0.11 per pound of copper payable after deducting by-product credits for gold, molybdenum, silver, rhenium, selenium and palladium.

Total operating costs excluding royalties are estimated at \$43.5 billion for the 45-year mine producing 30.5 billion pounds of copper. By-product credits total \$57.9 billion for the life-of-mine.

Based on the project economics there are an estimated 54.1 billion equivalent pounds of copper produced at the Pebble Project in the Reference Case.

Figure 18.8.2 shows the annual realization charges and operating costs on the left axis in millions of dollars and the copper cash cost shown per pound of copper payable on the right axis for the 45-year Reference Case.

**Figure 18.8.2 Cash Cost – 45-Year Reference Case**



## NET SMELTER RETURN

The total Net Smelter Return (NSR) for the Pebble Project and composition by metal are listed in Table 18.8.21 for the 45-year Reference Case.

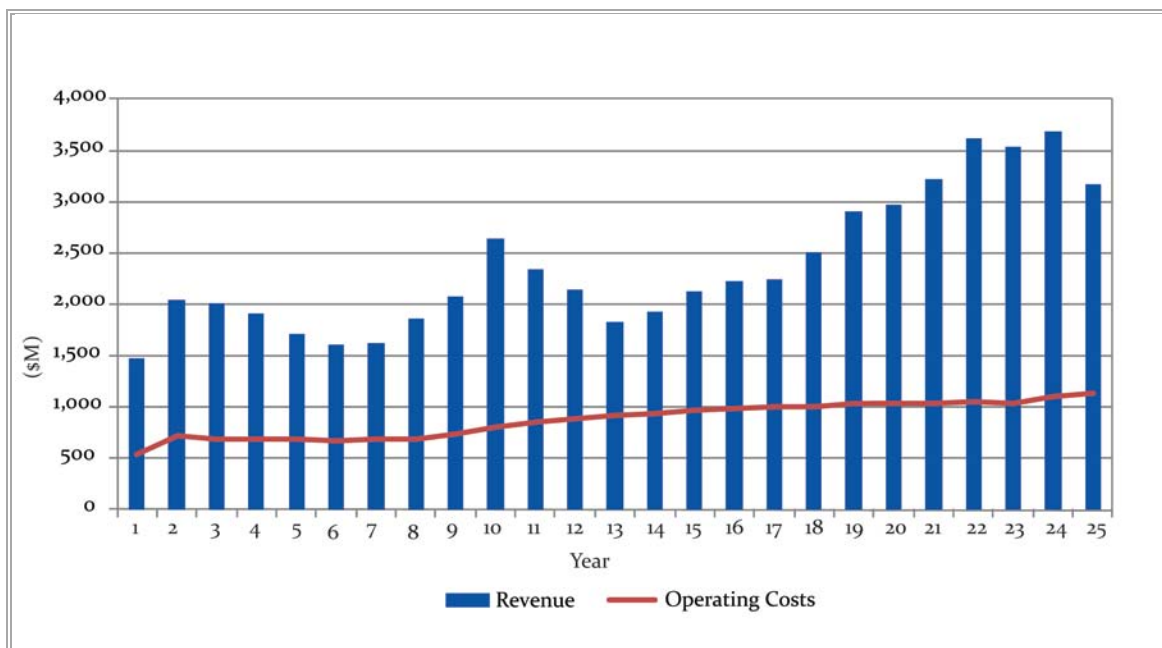
**Table 18.8.21 Net Smelter Return – 45-Year Reference Case**

Description	Unit	Value
NSR LOM	\$M	120,197
NSR Annual Average	\$M	2,671
Copper	%	55
Gold	%	24
Molybdenum	%	16
Other	%	5
NSR per ton milled	\$/ton	31.91

## OPERATING COSTS AND REVENUE

Figure 18.8.3 illustrates the relationship between project revenue and project operating costs in millions of dollars for the 45-year Reference Case.

**Figure 18.8.3 Revenue vs. Operating Costs – 45-Year Reference Case**

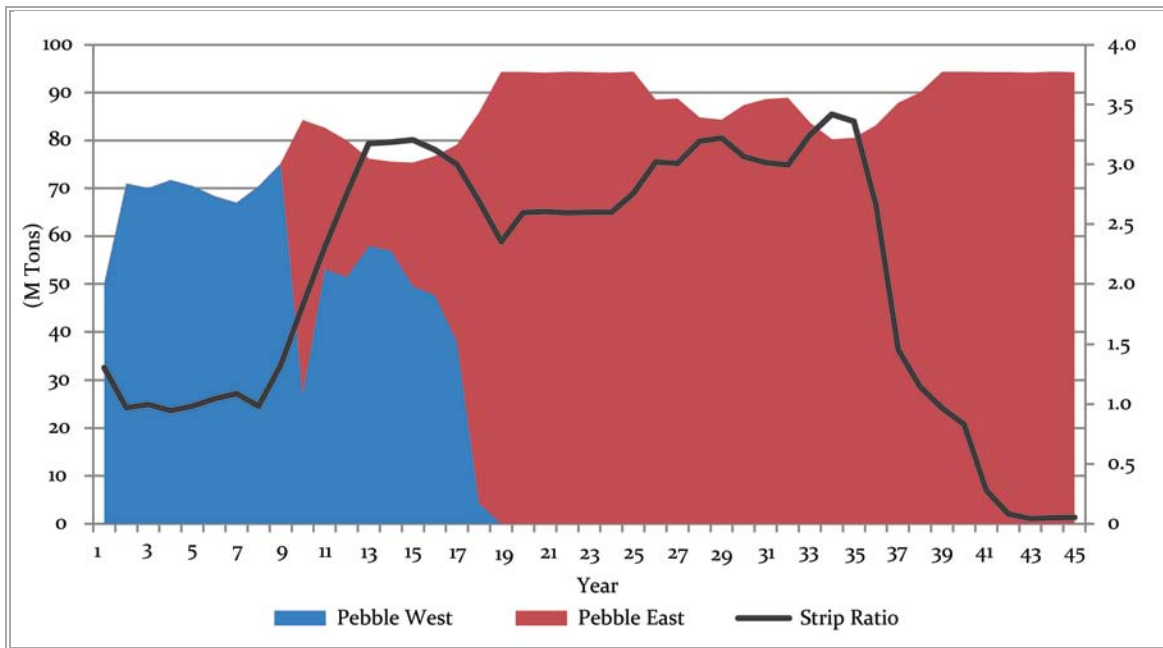


## CASH FLOW

Figure 18.8.4 illustrates the annual project post-tax cash flows for the 45-year Reference Case.



**Figure 18.8.4 Project Post-Tax Cash Flow – 45-Year Reference Case**



**SENSITIVITY ANALYSIS**

Sensitivity analyses have been carried out on the following parameters:

- copper, gold and molybdenum prices
- initial capital expenditure
- mine site operating costs.

The analyses are presented graphically as financial outcomes in terms of NPV and IRR (Figure 18.8.5 and Figure 18.8.6). The project pre-tax NPV (7% discount) is most sensitive to metal prices, operating costs, and capital costs in decreasing order.

**METAL PRICE MATRICES**

Table 18.8.22 to Table 18.8.25 illustrate the 45-year Reference Case’s sensitivity to a range of copper and gold prices in both pre-tax and post-tax evaluations with other metal prices held constant. The NPV<sub>7</sub> matrices are shown in \$ billions.

Figure 18.8.5 Pre-Tax NPV<sub>7</sub> Sensitivity to Inputs – 45-Year Reference Case (\$B)

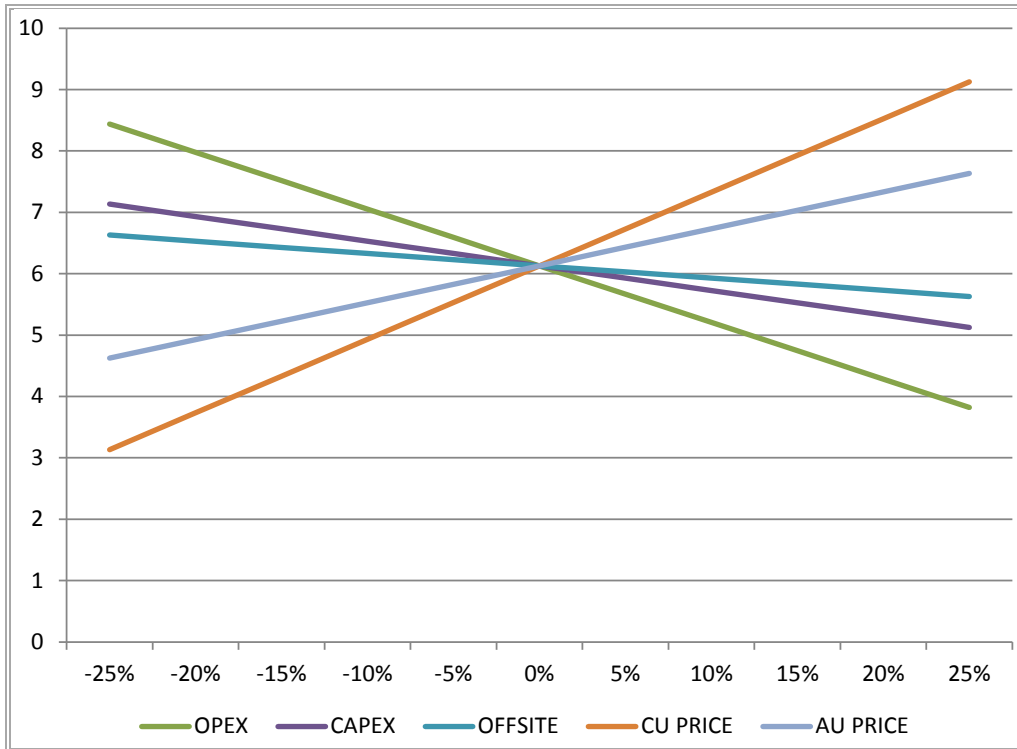
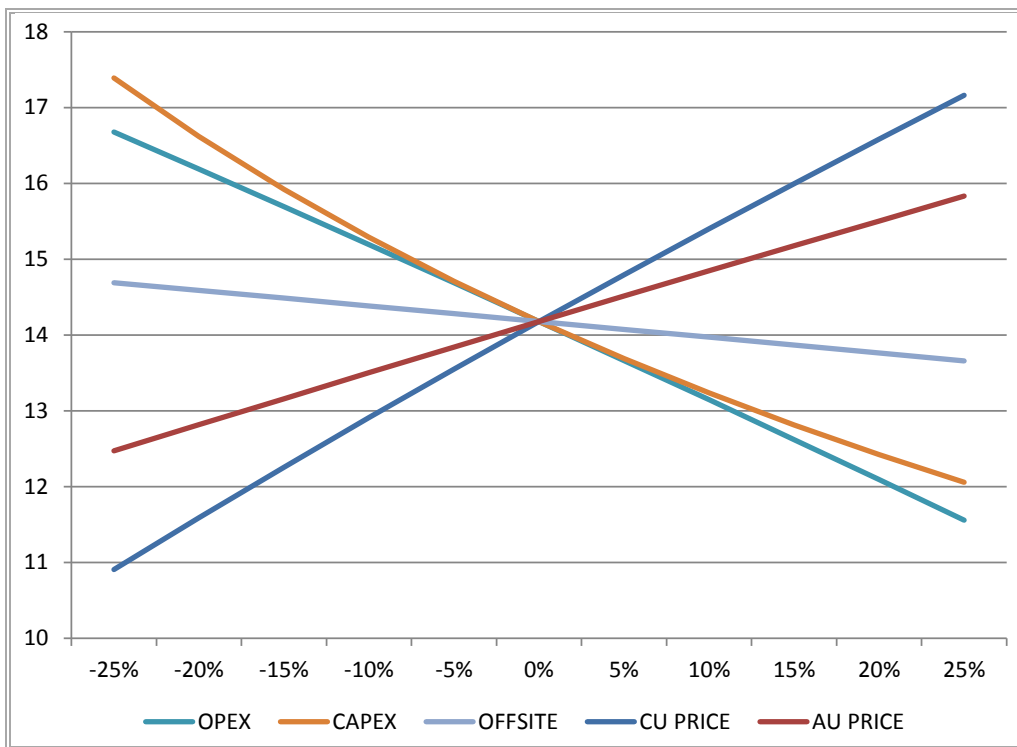


Figure 18.8.6 Pre-Tax IRR Chart Sensitivity to Inputs – 45-Year Reference Case (%)



**Table 18.8.22 Pre-Tax NPV<sub>7</sub> Metal Price Matrix – 45-Year Reference Case**

		Copper Price (\$/lb)												
		2.00	2.25	2.50	2.75	3.00	3.25	3.50	3.75	4.00	4.25	4.50	4.75	5.00
Gold Price (\$/oz)	700	1.72	2.92	4.12	5.32	6.52	7.72	8.92	10.12	11.32	12.52	13.72	14.91	16.11
	750	2.01	3.21	4.41	5.61	6.81	8.01	9.21	10.40	11.60	12.80	14.00	15.20	16.40
	800	2.30	3.50	4.70	5.89	7.09	8.29	9.49	10.69	11.89	13.09	14.29	15.49	16.69
	850	2.59	3.78	4.98	6.18	7.38	8.58	9.78	10.98	12.18	13.38	14.58	15.77	16.97
	900	2.87	4.07	5.27	6.47	7.67	8.87	10.07	11.26	12.46	13.66	14.86	16.06	17.26
	950	3.16	4.36	5.56	6.75	7.95	9.15	10.35	11.55	12.75	13.95	15.15	16.35	17.55
	1000	3.45	4.64	5.84	7.04	8.24	9.44	10.64	11.84	13.04	14.24	15.44	16.63	17.83
	1050	3.73	4.93	6.13	7.33	8.53	9.73	10.93	12.12	13.32	14.52	15.72	16.92	18.12
	1100	4.02	5.22	6.42	7.61	8.81	10.01	11.21	12.41	13.61	14.81	16.01	17.21	18.41
	1150	4.31	5.50	6.70	7.90	9.10	10.30	11.50	12.70	13.90	15.10	16.30	17.49	18.69
	1200	4.59	5.79	6.99	8.19	9.39	10.59	11.79	12.98	14.18	15.38	16.58	17.78	18.98
	1250	4.88	6.08	7.28	8.47	9.67	10.87	12.07	13.27	14.47	15.67	16.87	18.07	19.27
	1300	5.16	6.36	7.56	8.76	9.96	11.16	12.36	13.56	14.76	15.96	17.16	18.35	19.55
	1350	5.45	6.65	7.85	9.05	10.25	11.45	12.65	13.84	15.04	16.24	17.44	18.64	19.84
	1400	5.74	6.94	8.14	9.33	10.53	11.73	12.93	14.13	15.33	16.53	17.73	18.93	20.13
	1450	6.02	7.22	8.42	9.62	10.82	12.02	13.22	14.42	15.62	16.82	18.01	19.21	20.41
1500	6.31	7.51	8.71	9.91	11.11	12.31	13.51	14.70	15.90	17.10	18.30	19.50	20.70	

**Table 18.8.23 Pre-Tax IRR Metal Price Matrix – 45-Year Reference Case**

		Copper Price (\$/lb)												
		2.00	2.25	2.50	2.75	3.00	3.25	3.50	3.75	4.00	4.25	4.50	4.75	5.00
Gold Price (\$/oz)	700	9.1%	10.6%	11.9%	13.2%	14.4%	15.6%	16.8%	17.9%	19.0%	20.1%	21.2%	22.2%	23.2%
	750	9.5%	10.9%	12.2%	13.5%	14.7%	15.9%	17.1%	18.2%	19.3%	20.4%	21.4%	22.4%	23.4%
	800	9.9%	11.2%	12.6%	13.8%	15.0%	16.2%	17.4%	18.5%	19.6%	20.7%	21.7%	22.7%	23.7%
	850	10.2%	11.6%	12.9%	14.1%	15.4%	16.5%	17.7%	18.8%	19.9%	20.9%	22.0%	23.0%	23.9%
	900	10.6%	11.9%	13.2%	14.5%	15.7%	16.8%	18.0%	19.1%	20.2%	21.2%	22.2%	23.2%	24.2%
	950	10.9%	12.2%	13.5%	14.8%	16.0%	17.1%	18.3%	19.4%	20.4%	21.5%	22.5%	23.5%	24.4%
	1000	11.2%	12.6%	13.9%	15.1%	16.3%	17.4%	18.6%	19.6%	20.7%	21.7%	22.8%	23.7%	24.7%
	1050	11.6%	12.9%	14.2%	15.4%	16.6%	17.7%	18.8%	19.9%	21.0%	22.0%	23.0%	24.0%	24.9%
	1100	11.9%	13.2%	14.5%	15.7%	16.9%	18.0%	19.1%	20.2%	21.3%	22.3%	23.3%	24.2%	25.2%
	1150	12.3%	13.6%	14.8%	16.0%	17.2%	18.3%	19.4%	20.5%	21.5%	22.5%	23.5%	24.5%	25.4%
	1200	12.6%	13.9%	15.1%	16.3%	17.5%	18.6%	19.7%	20.8%	21.8%	22.8%	23.8%	24.7%	25.7%
	1250	12.9%	14.2%	15.4%	16.6%	17.8%	18.9%	20.0%	21.0%	22.1%	23.1%	24.0%	25.0%	25.9%
	1300	13.3%	14.5%	15.8%	16.9%	18.1%	19.2%	20.3%	21.3%	22.3%	23.3%	24.3%	25.2%	26.2%
	1350	13.6%	14.9%	16.1%	17.2%	18.4%	19.5%	20.5%	21.6%	22.6%	23.6%	24.5%	25.5%	26.4%
	1400	13.9%	15.2%	16.4%	17.5%	18.7%	19.7%	20.8%	21.8%	22.8%	23.8%	24.8%	25.7%	26.7%
	1450	14.2%	15.5%	16.7%	17.8%	18.9%	20.0%	21.1%	22.1%	23.1%	24.1%	25.0%	26.0%	26.9%
1500	14.6%	15.8%	17.0%	18.1%	19.2%	20.3%	21.4%	22.4%	23.4%	24.3%	25.3%	26.2%	27.1%	

**Table 18.8.24 Post-Tax NPV<sub>7</sub> Metal Price Matrix – 45-Year Reference Case**

		Copper Price (\$/lb)												
		2.00	2.25	2.50	2.75	3.00	3.25	3.50	3.75	4.00	4.25	4.50	4.75	5.00
Gold Price (\$/oz)	700	0.76	1.69	2.61	3.51	4.40	5.27	6.13	6.99	7.84	8.67	9.49	10.31	11.11
	750	0.99	1.92	2.83	3.73	4.61	5.48	6.34	7.20	8.04	8.87	9.69	10.50	11.31
	800	1.21	2.14	3.05	3.94	4.82	5.69	6.55	7.40	8.24	9.07	9.89	10.69	11.50
	850	1.44	2.36	3.26	4.15	5.03	5.90	6.76	7.61	8.44	9.26	10.08	10.89	11.69
	900	1.66	2.58	3.48	4.37	5.24	6.10	6.96	7.81	8.64	9.46	10.28	11.08	11.88
	950	1.88	2.79	3.69	4.58	5.45	6.31	7.17	8.01	8.84	9.66	10.47	11.27	12.07
	1000	2.10	3.01	3.91	4.79	5.65	6.52	7.37	8.21	9.03	9.85	10.66	11.47	12.27
	1050	2.32	3.23	4.12	5.00	5.86	6.73	7.58	8.41	9.23	10.05	10.86	11.66	12.46
	1100	2.54	3.44	4.33	5.20	6.07	6.93	7.78	8.61	9.43	10.24	11.05	11.85	12.65
	1150	2.76	3.66	4.54	5.41	6.28	7.14	7.98	8.80	9.63	10.44	11.24	12.04	12.84
	1200	2.97	3.87	4.75	5.62	6.49	7.34	8.18	9.00	9.82	10.63	11.43	12.23	13.03
	1250	3.19	4.08	4.96	5.83	6.69	7.55	8.38	9.20	10.02	10.82	11.63	12.42	13.22
	1300	3.40	4.30	5.17	6.04	6.90	7.75	8.58	9.40	10.21	11.02	11.82	12.62	13.41
	1350	3.62	4.51	5.38	6.25	7.11	7.95	8.77	9.60	10.41	11.21	12.01	12.81	13.60
	1400	3.83	4.72	5.59	6.46	7.31	8.15	8.97	9.79	10.60	11.40	12.20	13.00	13.79
	1450	4.05	4.93	5.80	6.66	7.51	8.35	9.17	9.99	10.79	11.59	12.39	13.19	13.98
1500	4.26	5.14	6.01	6.87	7.72	8.54	9.37	10.18	10.98	11.79	12.58	13.38	14.17	

**Table 18.8.25 Post-Tax IRR Metal Price Matrix – 45-Year Reference Case**

		Copper Price (\$/lb)												
		2.00	2.25	2.50	2.75	3.00	3.25	3.50	3.75	4.00	4.25	4.50	4.75	5.00
Gold Price (\$/oz)	700	8.1%	9.4%	10.6%	11.7%	12.8%	13.8%	14.8%	15.8%	16.7%	17.6%	18.5%	19.4%	20.2%
	750	8.4%	9.7%	10.9%	12.0%	13.1%	14.1%	15.1%	16.1%	17.0%	17.9%	18.7%	19.6%	20.4%
	800	8.7%	10.0%	11.2%	12.3%	13.3%	14.4%	15.3%	16.3%	17.2%	18.1%	19.0%	19.8%	20.6%
	850	9.0%	10.3%	11.4%	12.5%	13.6%	14.6%	15.6%	16.5%	17.4%	18.3%	19.2%	20.0%	20.8%
	900	9.4%	10.6%	11.7%	12.8%	13.9%	14.9%	15.8%	16.8%	17.7%	18.6%	19.4%	20.2%	21.0%
	950	9.7%	10.9%	12.0%	13.1%	14.1%	15.1%	16.1%	17.0%	17.9%	18.8%	19.6%	20.4%	21.2%
	1000	10.0%	11.2%	12.3%	13.4%	14.4%	15.4%	16.3%	17.2%	18.1%	19.0%	19.8%	20.6%	21.4%
	1050	10.3%	11.5%	12.6%	13.6%	14.6%	15.6%	16.6%	17.5%	18.4%	19.2%	20.0%	20.8%	21.6%
	1100	10.6%	11.7%	12.8%	13.9%	14.9%	15.9%	16.8%	17.7%	18.6%	19.4%	20.3%	21.0%	21.8%
	1150	10.9%	12.0%	13.1%	14.2%	15.2%	16.1%	17.1%	17.9%	18.8%	19.7%	20.5%	21.2%	22.0%
	1200	11.2%	12.3%	13.4%	14.4%	15.4%	16.4%	17.3%	18.2%	19.0%	19.9%	20.7%	21.5%	22.2%
	1250	11.5%	12.6%	13.7%	14.7%	15.7%	16.6%	17.5%	18.4%	19.3%	20.1%	20.9%	21.7%	22.4%
	1300	11.8%	12.9%	13.9%	14.9%	15.9%	16.9%	17.8%	18.6%	19.5%	20.3%	21.1%	21.9%	22.6%
	1350	12.1%	13.1%	14.2%	15.2%	16.2%	17.1%	18.0%	18.9%	19.7%	20.5%	21.3%	22.1%	22.8%
	1400	12.3%	13.4%	14.4%	15.4%	16.4%	17.3%	18.2%	19.1%	19.9%	20.7%	21.5%	22.3%	23.0%
	1450	12.6%	13.7%	14.7%	15.7%	16.6%	17.6%	18.4%	19.3%	20.1%	20.9%	21.7%	22.5%	23.2%
1500	12.9%	14.0%	15.0%	15.9%	16.9%	17.8%	18.7%	19.5%	20.3%	21.1%	21.9%	22.6%	23.4%	

#### 18.8.4 25-YEAR IDC CASE

The 25-Year IDC Case describes an initial 25-year open pit mine life upon which a decision to initiate mine permitting, construction and operations may be based. Of the three development cases, the 25-year IDC Case is the most comprehensively engineered. It seeks to mine near-surface ore for rapid payback, primarily in Measured and Indicated categories but also including a small proportion of Inferred material in the western portion of the Pebble deposit.

The 25-Year IDC Case achieves a pre-tax NPV of \$3.84 billion using a discounted cash flow approach to valuation. It achieves a pre-tax IRR of 13.4% and a payback period of 6.5 years. The 25-Year IDC Case produces 12.9 Blb of copper, 16.4 Moz of gold and 616 Mlb of molybdenum. Copper production is at a total cash cost of \$-0.10/lb after revenue credits from gold, molybdenum and other metals.

This initial phase of mining will process about two billion tons of ore or less than 20% of the total Pebble mineral resource. As such, it is not considered to be ideal for assessing the potential long-term economic value of the project. Inferred resources comprise 16% of total ore mined under the 25-year IDC Case.

*It should be noted that Inferred mineral resources are considered to be too speculative to allow the application of technical and economic parameters to support mine planning and the evaluation of the economic viability of the project. As such, there is currently no certainty that development cases incorporating Inferred mineral resources can be realized.*

#### PROJECT RESULTS

**Table 18.8.26 Project Results – 25-Year IDC Case**

Item	Unit	IDC Cases
<b>Production Results</b>		
Tons Mined	M ton	5,004
Strip Ratio	waste:ore	1.5
Tons Milled	M ton	1,990
Copper Equivalent Grade	%	0.72
Copper Grade	%	0.38
Gold Grade	oz/ton	0.012
Molybdenum Grade	ppm	182
Copper Recovery	%	86.6
Gold Recovery	%	71.5
Molybdenum Recovery	%	84.8
<b>Total Production – LOM Total</b>		
Copper Equivalent	Mlb	24,483
Copper	Mlb	12,944
Gold	k oz	16,391
Molybdenum	Mlb	616
Silver	k oz	67,205
Rhenium	k kg	502

*Table continues...*

...Table 18.8.26 (cont'd)

Item	Unit	IDC Cases	
		Average	Peak
Palladium	k oz	385	
Annual Production		<b>Average</b>	<b>Peak</b>
Copper Equivalent	Mlb	979	1,518
Copper	Mlb	518	822
Gold	k oz	656	1,038
Molybdenum	Mlb	25	43
Silver	k oz	2,688	3,471
Rhenium	k kg	20	35
Palladium	k oz	15	24
<b>Financial Results</b>		<b>Pre-Tax</b>	<b>Post-Tax</b>
Pre-Tax NPV at 0%	\$M	20,123	14,824
Pre-Tax NPV at 5%	\$M	6,363	4,407
<b>Pre-Tax NPV at 7%</b>	<b>\$M</b>	<b>3,837</b>	<b>2,475</b>
Pre-Tax NPV at 8%	\$M	2,901	1,756
Pre-Tax NPV at 10%	\$M	1,485	665
Pre-Tax IRR	%	13.4	11.7
Payback	years	6.5	6.9
Initial Capital	\$M	4,695	
Sustaining Capital	\$M	3,204	
<b>Net Smelter Return</b>			
Total	\$M	54,637	
Annual Average	\$M	2,185	
Copper	%	52	
Gold	%	29	
Molybdenum	%	15	
NSR per ton milled	\$/ton	27.45	
<b>Operating and Cash Costs</b>			
Total	\$M	22,208	
Annual Average	\$M	888	
Operating Cost	\$/ton	11.16	
Copper Cash Cost	\$ / lb	2.17	
C1 Copper Cost*	\$ / lb	-0.10	

\* C1 Copper Cost is Copper Cash Cost after by-product credits at long-term metal prices

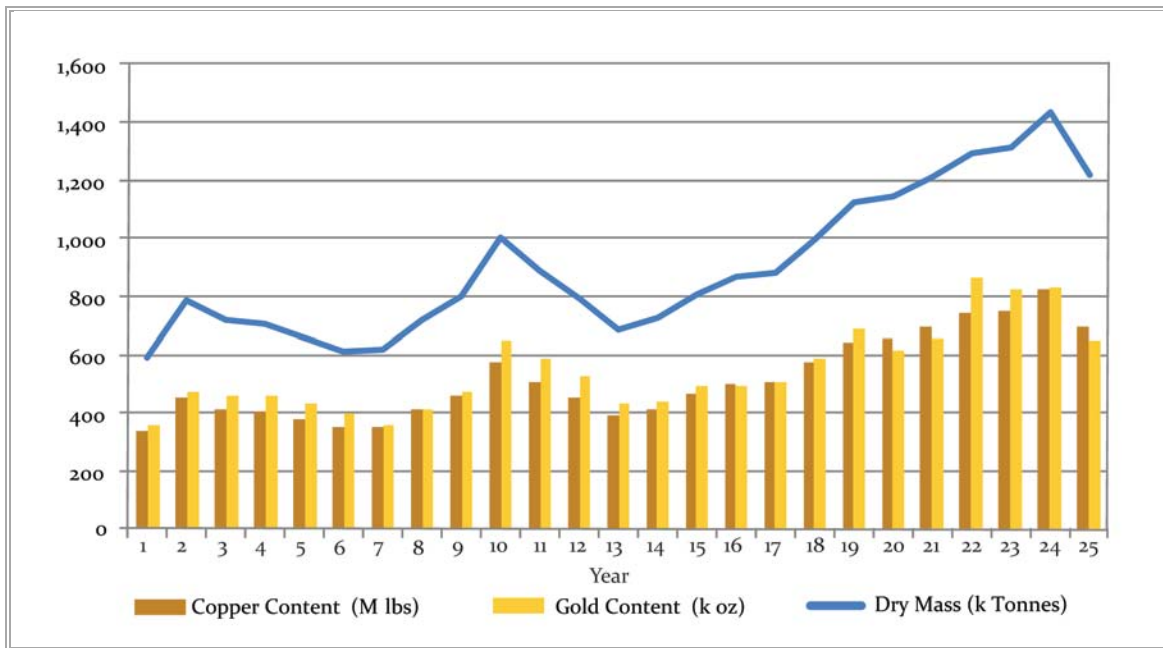
#### CONCENTRATE PRODUCTION STATISTICS

The 25-year IDC Case production statistics for copper-gold concentrate, including copper and gold metal, and molybdenum concentrate are illustrated in Table 18.8.27 and Figure 18.8.7.

**Table 18.8.27 Concentrate Statistics – 25-Year IDC Case**

Description	Unit	Value
<b>Copper Concentrate</b>		
Cu Concentrate Produced	K DMT	22,582
Copper Grade	% Cu	26%
Gold Grade	g/DMT	18.9
Silver Grade	g/DMT	79.8
Palladium Grade	g/DMT	0.53
Concentrate Moisture Content	%	7.5%
<b>Molybdenum Concentrate</b>		
Mo Concentrate Produced	k DMT	537
Molybdenum Grade	% Mo	52
Rhenium Grade	ppm	1,100
Concentrate Moisture Content	%	7.5%

**Figure 18.8.7 Copper-Gold Concentrate Produced – 25-Year IDC Case**



**SUSTAINING CAPITAL**

The 25-year IDC Case sustaining capital breakdown is shown in Table 18.8.28.

**Table 18.8.28 Sustaining Capital Costs – 25-Year IDC Case**

Area	Cost (\$M)	Cost (\$M/yr)
Open Pit	2,047	81.9
Processing	146	5.9
Infrastructure	12	0.5
Waste Management	846	33.8
Other	70	2.8
Molybdenum Autoclave	83	3.3
<b>Total</b>	<b>3,204</b>	<b>128.2</b>

#### OPERATING COSTS

Fixed and variable operating costs for open pit, tailings, process, general and administration (G&A), environmental and transportation areas have been derived by each discipline and applied annually to the mine plan tonnage. Table 18.8.29 lists total operating costs for the 25-year IDC Case.

**Table 18.8.29 Total Operating Costs – 25-Year IDC Case**

Area	Cost (\$M)	Cost (\$/ton milled)
Open Pit	7,628	3.83
Process	8,966	4.50
Transportation	1,933	0.97
Environmental	604	0.30
G&A	3,077	1.56
<b>Total</b>	<b>22,208</b>	<b>11.16</b>

#### OFFSITE CHARGES

Offsite charges for metal treatment and refinement, freight and insurance have calculated annually and are listed in Table 18.8.30 for the 25-year IDC Case.

**Table 18.8.30 Offsite Charges – 25-Year IDC Case**

Area	Cost (\$M)	Cost (\$/ton milled)
Cu Treatment	2,452	1.23
Mo Treatment	76	0.04
Au Treatment	906	0.46
Ag Treatment	59	0.03
Freight and Insurance	1,259	0.63
<b>Total</b>	<b>4,752</b>	<b>2.39</b>



**CASH COST ANALYSIS**

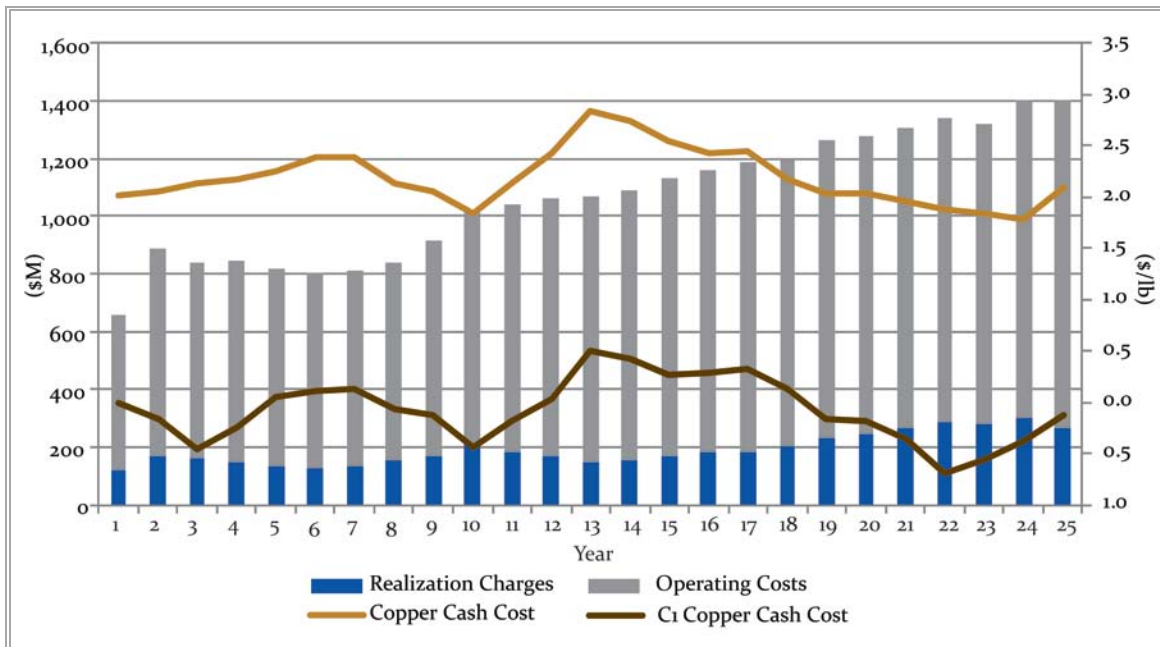
The life-of-mine copper cash cost for the 25-year IDC Case is \$2.17/lb of copper payable (not including by-product credits but including total realization and operating costs for the project) and a C<sub>1</sub> copper cash cost estimated at -\$0.10 per pound of copper payable after deducting by-product credits for gold, molybdenum, silver, rhenium, selenium and palladium.

Total operating costs excluding royalties are estimated at \$22.2 billion for the 25-year mine producing 12.9 Blb of copper. By-product credits total \$28.2 billion for the life-of-mine.

Based on the project economics there are an estimated 24.5 billion equivalent pounds of copper at the Pebble Project in the 25-year IDC Case.

Figure 18.8.8 shows the annual realization charges and operating costs on the left axis in millions of dollars and the copper cash cost shown in per pound of copper payable on the right axis for the 25-year IDC Case.

**Figure 18.8.8 Cash Cost – 25-Year IDC Case**



**NET SMELTER RETURN**

The total Net Smelter Return (NSR) for the Pebble project and composition by metal are listed in Table 18.8.31 for the 25-year IDC Case.

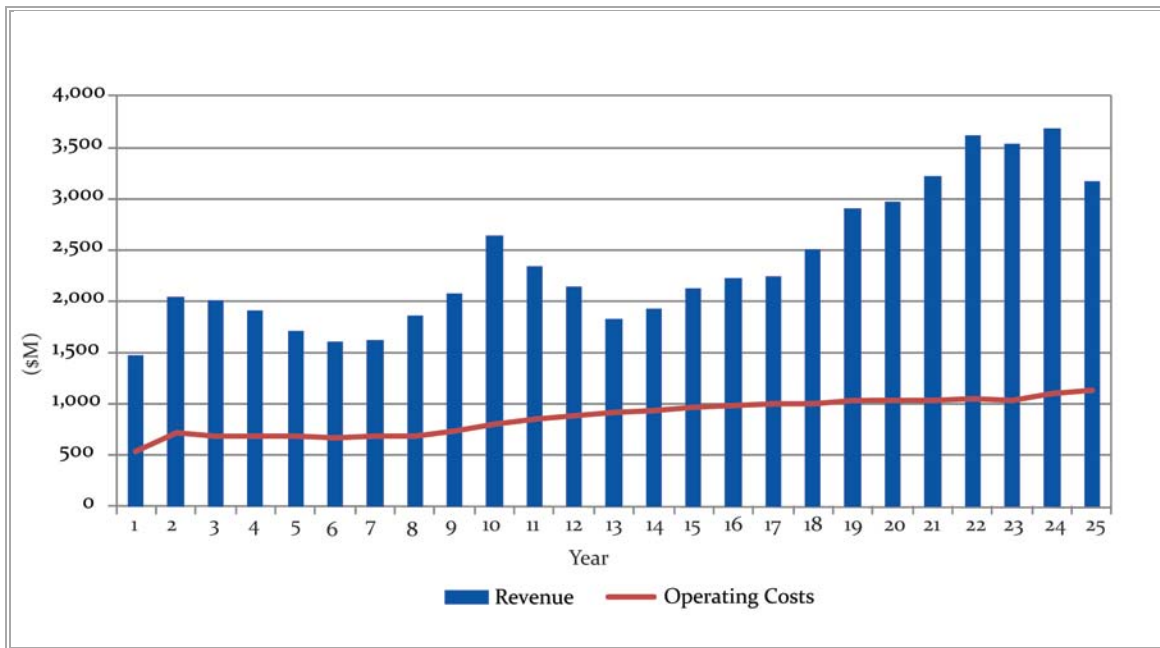
**Table 18.8.31 Net Smelter Return – 25-Year IDC Case**

Description	Unit	Value
NSR LOM	\$M	54,637
NSR Annual Avg	\$M	2,185
Copper	%	52
Gold	%	29
Molybdenum	%	15
Other	%	5
NSR per ton milled	\$/ton	27.45

**OPERATING COSTS AND REVENUE**

Figure 18.8.9 illustrates the relationship between project revenue and project operating costs in millions of dollars for the 25-year IDC Case.

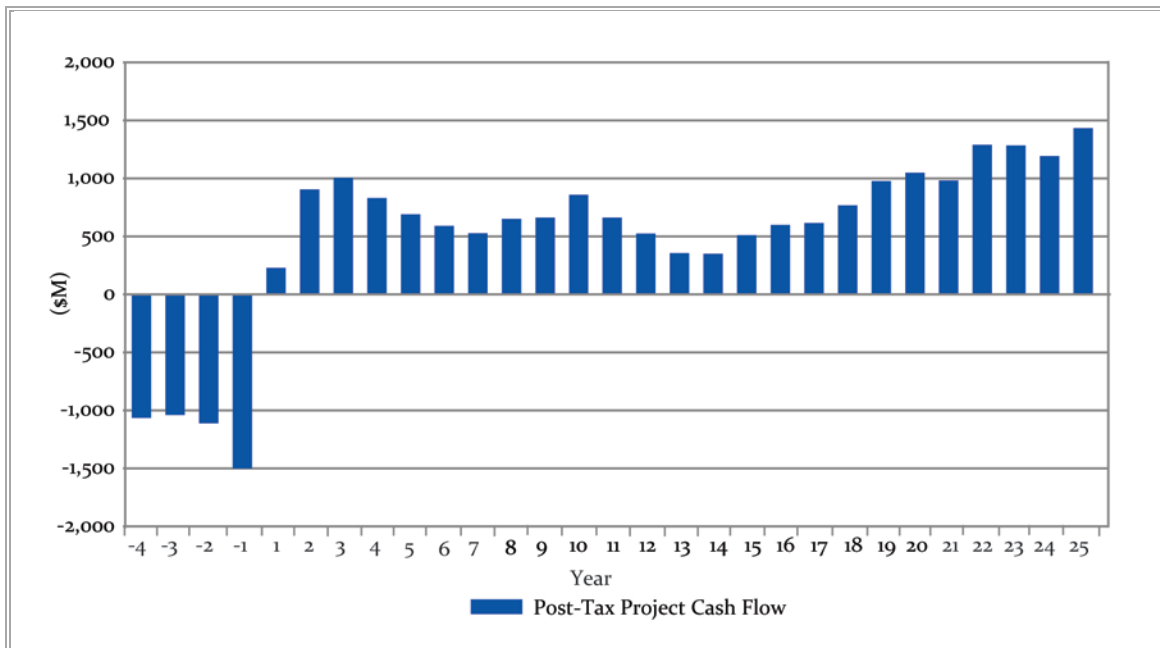
**Figure 18.8.9 Revenue vs. Operating Costs – 25-Year IDC Case**



**CASH FLOW**

Figure 18.8.10 illustrates the annual project post-tax cash flows for the 25-year IDC case.

**Figure 18.8.10 Project Post-tax Cash Flow – 25-Year IDC Case (\$M)**



**SENSITIVITY ANALYSIS**

Sensitivity analyses have been carried out on the following parameters:

- copper, gold and molybdenum prices;
- initial capital expenditure; and
- mine site operating costs.

The analyses are presented graphically as financial outcomes in terms of NPV<sub>7</sub> and IRR (Figure 18.8.11 and Figure 18.8.12). The project pre-tax NPV (7% discount) is most sensitive to metal prices, operating costs, and capital costs in decreasing order.

**METAL PRICE MATRICES**

Table 18.8.32 to Table 18.8.35 illustrate the 25-year IDC Case’s sensitivity to a range of copper and gold prices in both pre-tax and post-tax evaluations with other metal prices held constant. The NPV<sub>7</sub> matrices are shown in \$ billions.

Figure 18.8.11 Pre-Tax NPV<sub>7</sub> Sensitivity to Inputs – 25-Year IDC Case

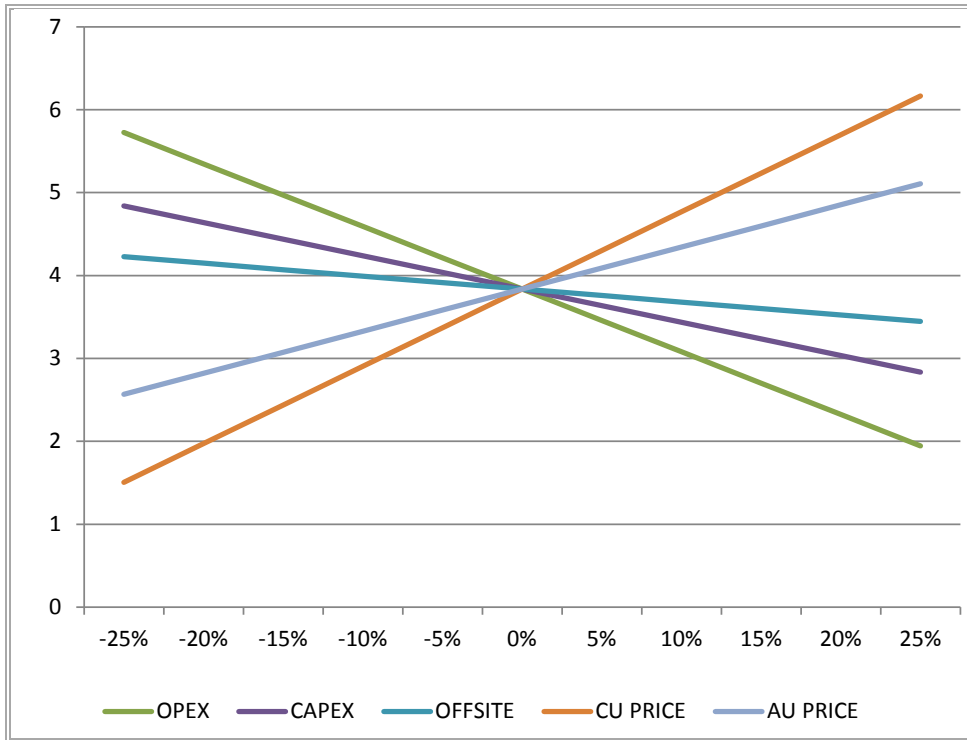
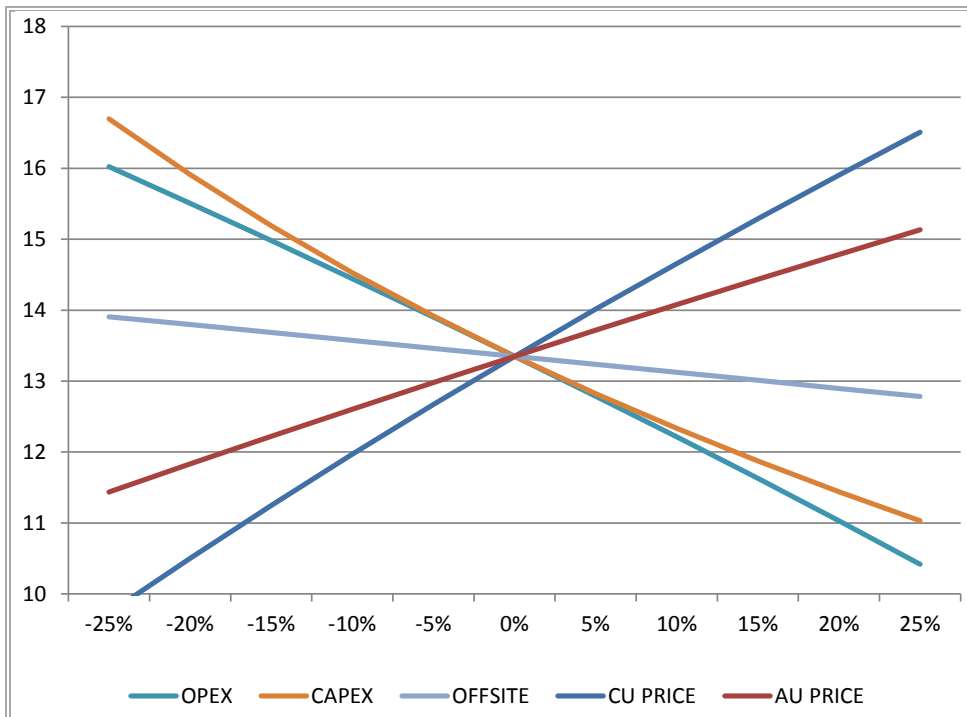


Figure 18.8.12 Pre-Tax IRR Chart Sensitivity to Inputs – 25-Year IDC Case



**Table 18.8.32 Pre-Tax NPV<sub>7</sub> Metal Price Matrix – 25-Year IDC Case**

Gold Price (\$/oz)	Copper Price (\$/lb)												
	2.00	2.25	2.50	2.75	3.00	3.25	3.50	3.75	4.00	4.25	4.50	4.75	5.00
700	0.28	1.21	2.14	3.07	4.01	4.94	5.87	6.80	7.73	8.67	9.60	10.53	11.46
750	0.52	1.45	2.38	3.32	4.25	5.18	6.11	7.04	7.98	8.91	9.84	10.77	11.70
800	0.76	1.69	2.63	3.56	4.49	5.42	6.35	7.28	8.22	9.15	10.08	11.01	11.94
850	1.00	1.94	2.87	3.80	4.73	5.66	6.59	7.53	8.46	9.39	10.32	11.25	12.19
900	1.25	2.18	3.11	4.04	4.97	5.91	6.84	7.77	8.70	9.63	10.56	11.50	12.43
950	1.49	2.42	3.35	4.28	5.22	6.15	7.08	8.01	8.94	9.87	10.81	11.74	12.67
1000	1.73	2.66	3.59	4.53	5.46	6.39	7.32	8.25	9.18	10.12	11.05	11.98	12.91
1050	1.97	2.90	3.84	4.77	5.70	6.63	7.56	8.50	9.43	10.36	11.29	12.22	13.15
1100	2.21	3.15	4.08	5.01	5.94	6.87	7.80	8.74	9.67	10.60	11.53	12.46	13.39
1150	2.46	3.39	4.32	5.25	6.18	7.11	8.05	8.98	9.91	10.84	11.77	12.71	13.64
1200	2.70	3.63	4.56	5.49	6.42	7.36	8.29	9.22	10.15	11.08	12.02	12.95	13.88
1250	2.94	3.87	4.80	5.74	6.67	7.60	8.53	9.46	10.39	11.33	12.26	13.19	14.12
1300	3.18	4.11	5.05	5.98	6.91	7.84	8.77	9.70	10.64	11.57	12.50	13.43	14.36
1350	3.42	4.36	5.29	6.22	7.15	8.08	9.01	9.95	10.88	11.81	12.74	13.67	14.60
1400	3.67	4.60	5.53	6.46	7.39	8.32	9.26	10.19	11.12	12.05	12.98	13.91	14.85
1450	3.91	4.84	5.77	6.70	7.63	8.57	9.50	10.43	11.36	12.29	13.22	14.16	15.09
1500	4.15	5.08	6.01	6.94	7.88	8.81	9.74	10.67	11.60	12.53	13.47	14.40	15.33

**Table 18.8.33 Pre-Tax IRR Metal Price Matrix – 25-Year IDC Case**

Gold Price (\$/oz)	Copper Price (\$/lb)												
	2.00	2.25	2.50	2.75	3.00	3.25	3.50	3.75	4.00	4.25	4.50	4.75	5.00
700	7.5%	9.2%	10.8%	12.2%	13.6%	14.9%	16.1%	17.3%	18.4%	19.5%	20.6%	21.6%	22.6%
750	8.0%	9.6%	11.2%	12.6%	13.9%	15.2%	16.4%	17.6%	18.7%	19.8%	20.9%	21.9%	22.9%
800	8.4%	10.0%	11.5%	12.9%	14.3%	15.5%	16.7%	17.9%	19.0%	20.1%	21.2%	22.2%	23.2%
850	8.9%	10.4%	11.9%	13.3%	14.6%	15.8%	17.0%	18.2%	19.3%	20.4%	21.4%	22.4%	23.4%
900	9.3%	10.8%	12.3%	13.6%	14.9%	16.2%	17.3%	18.5%	19.6%	20.7%	21.7%	22.7%	23.7%
950	9.7%	11.2%	12.6%	14.0%	15.3%	16.5%	17.7%	18.8%	19.9%	20.9%	22.0%	23.0%	23.9%
1000	10.1%	11.6%	13.0%	14.3%	15.6%	16.8%	18.0%	19.1%	20.2%	21.2%	22.2%	23.2%	24.2%
1050	10.5%	12.0%	13.4%	14.7%	15.9%	17.1%	18.2%	19.4%	20.4%	21.5%	22.5%	23.5%	24.4%
1100	10.9%	12.3%	13.7%	15.0%	16.2%	17.4%	18.5%	19.6%	20.7%	21.7%	22.7%	23.7%	24.7%
1150	11.3%	12.7%	14.0%	15.3%	16.5%	17.7%	18.8%	19.9%	21.0%	22.0%	23.0%	24.0%	24.9%
1200	11.7%	13.1%	14.4%	15.6%	16.8%	18.0%	19.1%	20.2%	21.3%	22.3%	23.3%	24.2%	25.2%
1250	12.0%	13.4%	14.7%	16.0%	17.2%	18.3%	19.4%	20.5%	21.5%	22.5%	23.5%	24.5%	25.4%
1300	12.4%	13.8%	15.1%	16.3%	17.5%	18.6%	19.7%	20.8%	21.8%	22.8%	23.8%	24.7%	25.7%
1350	12.8%	14.1%	15.4%	16.6%	17.8%	18.9%	20.0%	21.0%	22.1%	23.1%	24.0%	25.0%	25.9%
1400	13.1%	14.4%	15.7%	16.9%	18.1%	19.2%	20.3%	21.3%	22.3%	23.3%	24.3%	25.2%	26.1%
1450	13.5%	14.8%	16.0%	17.2%	18.4%	19.5%	20.5%	21.6%	22.6%	23.6%	24.5%	25.5%	26.4%
1500	13.8%	15.1%	16.3%	17.5%	18.7%	19.8%	20.8%	21.8%	22.9%	23.8%	24.8%	25.7%	26.6%

**Table 18.8.34 Post-Tax NPV<sub>7</sub> Metal Price Matrix – 25-Year IDC Case**

Gold Price (\$/oz)	Copper Price (\$/lb)												
	2.00	2.25	2.50	2.75	3.00	3.25	3.50	3.75	4.00	4.25	4.50	4.75	5.00
700	-0.28	0.46	1.19	1.90	2.60	3.30	3.99	4.69	5.36	6.01	6.66	7.31	7.95
750	-0.08	0.65	1.38	2.08	2.78	3.48	4.17	4.87	5.53	6.18	6.83	7.48	8.11
800	0.11	0.84	1.56	2.27	2.96	3.66	4.35	5.04	5.70	6.35	7.00	7.64	8.27
850	0.30	1.03	1.74	2.45	3.15	3.84	4.53	5.21	5.87	6.52	7.17	7.81	8.44
900	0.49	1.22	1.93	2.63	3.33	4.02	4.71	5.38	6.04	6.69	7.34	7.97	8.60
950	0.68	1.40	2.11	2.81	3.51	4.20	4.89	5.56	6.21	6.86	7.50	8.13	8.76
1000	0.87	1.59	2.29	2.99	3.69	4.38	5.07	5.73	6.38	7.03	7.67	8.30	8.93
1050	1.06	1.77	2.47	3.17	3.87	4.56	5.24	5.90	6.55	7.20	7.83	8.46	9.09
1100	1.25	1.96	2.66	3.35	4.05	4.74	5.41	6.07	6.72	7.36	8.00	8.63	9.25
1150	1.43	2.14	2.84	3.53	4.23	4.92	5.58	6.24	6.89	7.53	8.16	8.79	9.41
1200	1.62	2.32	3.02	3.71	4.41	5.09	5.75	6.41	7.05	7.69	8.32	8.95	9.58
1250	1.80	2.50	3.20	3.89	4.59	5.27	5.92	6.57	7.22	7.86	8.49	9.11	9.74
1300	1.98	2.68	3.38	4.08	4.77	5.44	6.09	6.74	7.39	8.02	8.65	9.28	9.90
1350	2.17	2.87	3.56	4.26	4.95	5.61	6.26	6.91	7.55	8.18	8.81	9.44	10.06
1400	2.35	3.05	3.74	4.44	5.12	5.78	6.43	7.08	7.72	8.35	8.98	9.60	10.22
1450	2.53	3.23	3.92	4.62	5.29	5.95	6.60	7.25	7.88	8.51	9.14	9.76	10.39
1500	2.71	3.41	4.10	4.80	5.46	6.12	6.77	7.41	8.05	8.68	9.30	9.93	10.55

**Table 18.8.35 Post-Tax IRR Metal Price Matrix – 25-Year IDC Case**

Gold Price (\$/oz)	Copper Price (\$/lb)												
	2.00	2.25	2.50	2.75	3.00	3.25	3.50	3.75	4.00	4.25	4.50	4.75	5.00
700	6.4%	8.0%	9.4%	10.7%	11.9%	13.0%	14.1%	15.1%	16.1%	17.1%	18.0%	18.8%	19.7%
750	6.8%	8.3%	9.7%	11.0%	12.2%	13.3%	14.4%	15.4%	16.4%	17.3%	18.2%	19.1%	19.9%
800	7.2%	8.7%	10.1%	11.3%	12.5%	13.6%	14.6%	15.7%	16.6%	17.5%	18.4%	19.3%	20.1%
850	7.6%	9.1%	10.4%	11.6%	12.8%	13.9%	14.9%	15.9%	16.9%	17.8%	18.7%	19.5%	20.3%
900	8.0%	9.4%	10.7%	11.9%	13.1%	14.2%	15.2%	16.2%	17.1%	18.0%	18.9%	19.7%	20.5%
950	8.4%	9.8%	11.1%	12.2%	13.4%	14.4%	15.4%	16.4%	17.3%	18.2%	19.1%	19.9%	20.7%
1000	8.8%	10.1%	11.4%	12.5%	13.6%	14.7%	15.7%	16.7%	17.6%	18.5%	19.3%	20.1%	20.9%
1050	9.1%	10.5%	11.7%	12.8%	13.9%	15.0%	16.0%	16.9%	17.8%	18.7%	19.5%	20.4%	21.1%
1100	9.5%	10.8%	12.0%	13.1%	14.2%	15.2%	16.2%	17.2%	18.1%	18.9%	19.8%	20.6%	21.4%
1150	9.8%	11.1%	12.3%	13.4%	14.5%	15.5%	16.5%	17.4%	18.3%	19.2%	20.0%	20.8%	21.6%
1200	10.2%	11.4%	12.6%	13.7%	14.7%	15.8%	16.7%	17.6%	18.5%	19.4%	20.2%	21.0%	21.8%
1250	10.5%	11.7%	12.9%	14.0%	15.0%	16.0%	17.0%	17.9%	18.7%	19.6%	20.4%	21.2%	22.0%
1300	10.8%	12.0%	13.2%	14.3%	15.3%	16.3%	17.2%	18.1%	19.0%	19.8%	20.6%	21.4%	22.2%
1350	11.2%	12.3%	13.5%	14.5%	15.5%	16.5%	17.4%	18.3%	19.2%	20.0%	20.8%	21.6%	22.4%
1400	11.5%	12.6%	13.7%	14.8%	15.8%	16.8%	17.7%	18.6%	19.4%	20.2%	21.0%	21.8%	22.5%
1450	11.8%	12.9%	14.0%	15.1%	16.1%	17.0%	17.9%	18.8%	19.6%	20.4%	21.2%	22.0%	22.7%
1500	12.1%	13.2%	14.3%	15.3%	16.3%	17.2%	18.1%	19.0%	19.8%	20.6%	21.4%	22.2%	22.9%

**18.8.5 78-YEAR RESOURCE CASE**

The 78-Year Resource Case is based on 78 years of open pit mine production and seeks to assess the longer-term value of the project in current dollars. The 78-year Resource Case will also require separate permitting and development decisions to be made in the future, based on prevailing conditions at the time and the accumulated experience gained from developing and operating the initial phase of the Pebble Project. The 78-year Resource Case is based on a continuation of mining methods, costs and assumptions that inform the 25-year IDC Case and the 45-year Reference Case. By developing some 61% of the Pebble mineral resource over eight decades, the 78-Year Resource Case is intended to demonstrate the longer-term economic value of the Pebble Project.

The 78-year Resource Case achieves a pre-tax NPV<sub>7</sub> of \$6.81 billion using a discounted cash flow approach to valuation. It achieves a pre-tax IRR of 14.5% and a payback period of 6.1 years. The 78-year Resource Case produces 53.4 Blb of copper, 50.1 Moz of gold and 2.8 Blb of molybdenum. Copper production is at a total cash cost of \$0.21/lb after revenue credits from gold, molybdenum and other metals.

The 78-year Resource Case will process a total of some 6.5 billion tons of ore, primarily in Measured and Indicated categories from both the western and eastern portions of the Pebble deposit. Inferred resources comprise 33% of the total ore mined.

*It should be noted that Inferred mineral resources are considered to be too speculative to allow the application of technical and economic parameters to support mine planning and the evaluation of the economic viability of the project. As such, there is currently no certainty that development cases incorporating Inferred mineral resources can be realized.*

**PROJECT RESULTS**

Table 18.8.36 shows the key outputs from the financial model for the 78-year Resource Case.

**Table 18.8.36 Project Results – 78-year Resource Case**

Item	Unit	
<b>Production Results</b>		
Tons Mined	M tons	23,714
Strip Ratio	waste:ore	2.6
Tons Milled	M tons	6,528
Copper Equivalent Grade	%	0.84
Copper Grade	%	0.46
Gold Grade	oz/ ton	0.011
Molybdenum Grade	ppm	243
Copper Recovery	%	88.4
Gold Recovery	%	71.2
Molybdenum Recovery	%	89.4

*Table continues...*

...Table 18.8.26 (cont'd)

Item	Unit		
<b>Total Production – LOM Total</b>			
Copper Equivalent	Mlb	96,357	
Copper	Mlb	53,437	
Gold	k oz	50,133	
Molybdenum	Mlb	2,835	
Silver	k oz	241,719	
Rhenium	k kg	2,312	
Palladium	k oz	1,589	
<b>Annual Production</b>		<b>Average</b>	<b>Peak</b>
Copper Equivalent	Mlb	1,235	1,931
Copper	Mlb	685	1,096
Gold	k oz	643	1,088
Molybdenum	Mlb	36	62
Silver	k oz	3,099	5,829
Rhenium	k kg	30	51
Palladium	k oz	20	33
<b>Financial Results</b>		<b>Pre-Tax</b>	<b>Post-Tax</b>
Pre-Tax NPV at 0%	\$M	87,329	64,328
Pre-Tax NPV at 5%	\$M	12,941	9,318
<b>Pre-Tax NPV at 7%</b>	<b>\$M</b>	<b>6,812</b>	<b>4,721</b>
Pre-Tax NPV at 8%	\$M	4,964	3,325
Pre-Tax NPV at 10%	\$M	2,545	1,485
Pre-Tax IRR	%	14.5	12.9
Payback	years	6.1	6.4
Initial Capital	\$M	4,695	
LOM Sustaining Capital	\$M	11,727	
<b>Net Smelter Return</b>			
Total	\$M	213,970	
Annual Average	\$M	2,743	
Copper	%	55	
Gold	%	22	
Molybdenum	%	18	
NSR Per Ton Milled	\$/ton	32.78	
<b>Operating and Cash Costs</b>			
Total	\$M	96,063	
Annual Average	\$M	1,232	
Operating Cost Per Ton Milled	\$/ton	14.72	
Copper Cash Cost	\$ / lb	2.26	
C1 Copper Cost*	\$ / lb	0.21	

\* C1 Copper Cost is Copper Cash Cost per payable pound after by-product credits at long-term metal prices



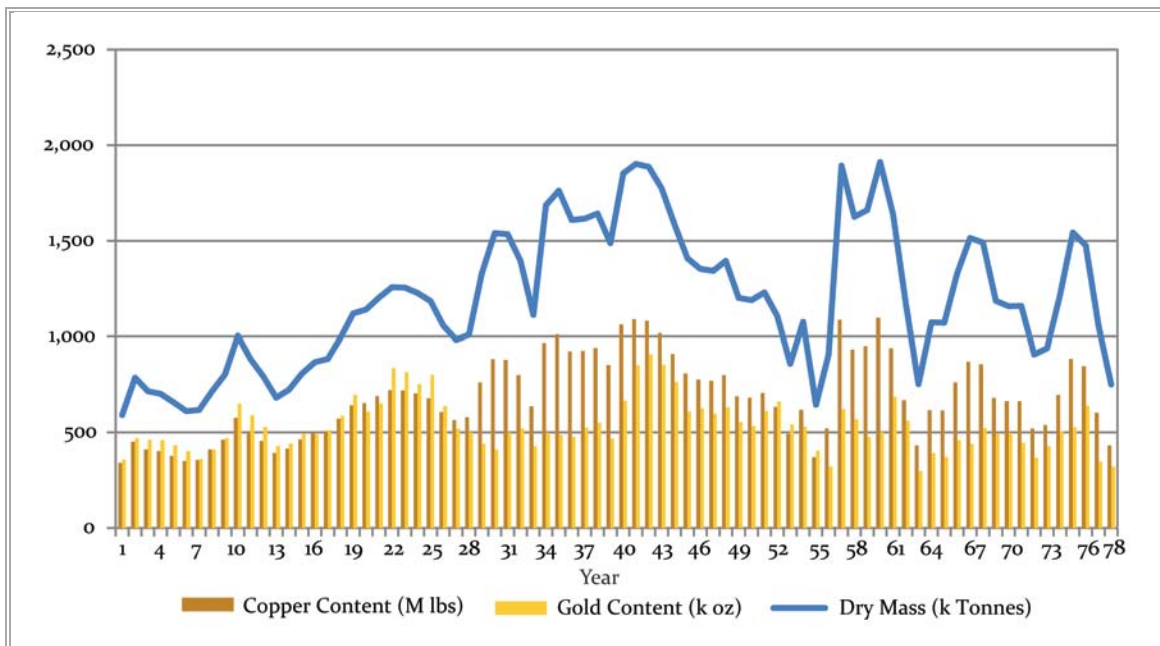
**CONCENTRATE PRODUCTION STATISTICS**

The 78-year Resource Case production statistics for copper-gold concentrate, including copper and gold metal, and molybdenum concentrate are illustrated in Table 18.8.37 and Figure 18.8.13.

**Table 18.8.37 Concentrate Statistics – 78-year Resource Case**

Description	Unit	Value
<b>Copper Concentrate</b>		
Cu Concentrate Produced	K DMT	93,225
Copper Grade	% Cu	26
Gold Grade	g/DMT	14.7
Silver Grade	g/DMT	69.5
Palladium Grade	g/DMT	0.53
Concentrate Moisture Content	%	7.5
<b>Molybdenum Concentrate</b>		
Mo Concentrate Produced	k DMT	2,473
Molybdenum Grade	% Mo	52
Rhenium Grade	ppm	1,100
Concentrate Moisture Content	%	7.5

**Figure 18.8.13 Copper-Gold Concentrate Produced – 78-year Resource Case**



**SUSTAINING CAPITAL**

The 78-year Resource Case sustaining capital breakdown is shown in Table 18.8.38.

**Table 18.8.38 Sustaining Capital Costs – 78-year Resource Case**

Area	Cost (\$M)	Cost (\$M/yr)
Open Pit	7,225	92.6
Processing	517	6.6
Infrastructure	165	2.1
Waste Management	3,364	43.1
Other	180	2.3
Molybdenum Autoclave	276	3.6
<b>Total</b>	<b>11,727</b>	<b>150.3</b>

### OPERATING COSTS

Fixed and variable operating costs for open pit, tailings, process, general and administration (G&A), environmental and transportation areas have been derived by each discipline and applied annually to the mine plan tonnage. Table 18.8.39 lists total operating costs for the 78-year Resource Case.

**Table 18.8.39 Total Operating Costs – 78-year Resource Case**

Area	Cost (\$M)	Cost (\$/ton milled)
Open Pit	46,927	7.19
Process	32,160	4.93
Transportation	5,928	0.91
Environmental	2,013	0.31
G&A	9,035	1.38
<b>Total</b>	<b>96,063</b>	<b>14.72</b>

### OFFSITE CHARGES

Offsite charges for metal treatment and refinement, freight and insurance have calculated annually and are listed in Table 18.8.40 for the 78-year Resource Case.

**Table 18.8.40 Offsite Charges – 78-year Resource Case**

Area	Cost (\$M)	Cost (\$/ton milled)
Cu Treatment	10,123	1.55
Mo Treatment	232	0.04
Au Treatment	4,164	0.64
Ag Treatment	212	0.03
Freight and Insurance	5,207	0.79
<b>Total</b>	<b>19,938</b>	<b>3.05</b>

**CASH COST ANALYSIS**

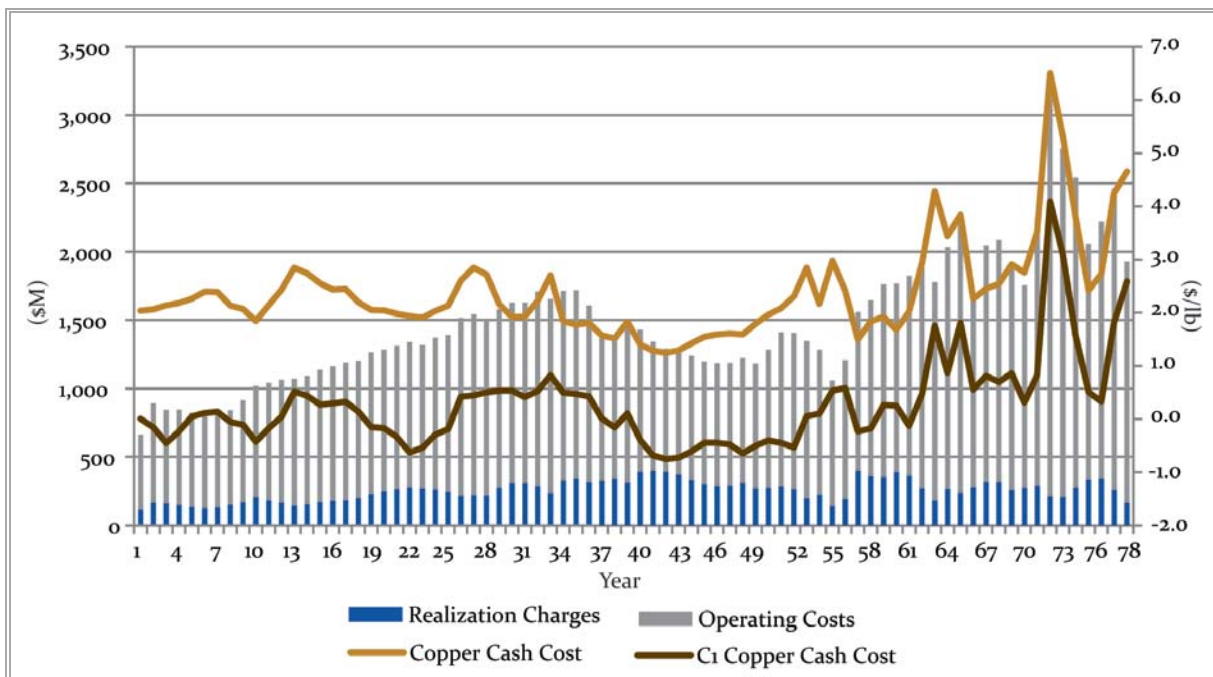
The life-of-mine copper cash cost for the 78-year Resource Case is \$2.26/lb of copper payable (not including by-product credits but including total realization and operating costs for the project) and a C1 copper cash cost estimated at \$0.21/lb of copper payable after deducting by-product credits for gold, molybdenum, silver, rhenium, selenium and palladium.

Total operating costs excluding royalties are estimated at \$96.1 billion for the 78-year mine producing 53.4 Blb of copper. By-product credits total \$105.2 billion for the life-of-mine.

Based on the project economics there are an estimated 96.4 billion equivalent pounds of copper produced at the Pebble Project in the 78-year Resource Case.

Figure 18.8.14 shows the annual realization charges and operating costs on the left axis in millions of dollars and the copper cash cost shown in per pound of copper payable on the right axis for the 78-year Resource Case.

**Figure 18.8.14 Cash Cost – 78-year Resource Case**



NET SMELTER RETURN

The total Net Smelter Return (NSR) for the Pebble project and composition by metal are listed in Table 18.8.41 for the 78-year Resource Case.

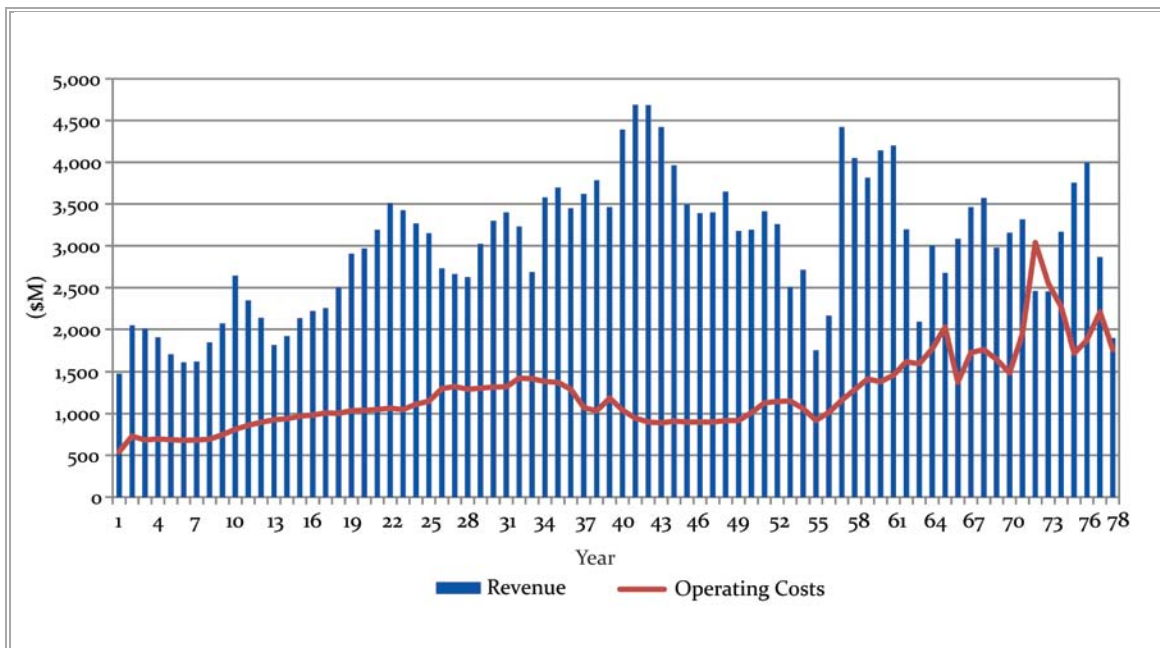
**Table 18.8.41 Net Smelter Return – 78-year Resource Case**

Description	Unit	Value
NSR LOM	\$M	213,970
NSR Annual Average	\$M	2,743
Copper	%	55
Gold	%	22
Molybdenum	%	18
Other	%	5
NSR Per Ton Milled	\$/ton	32.78

OPERATING COSTS AND REVENUE

Figure 18.8.15 illustrates the relationship between project revenue and project operating costs in millions of dollars for the 78-year Resource Case.

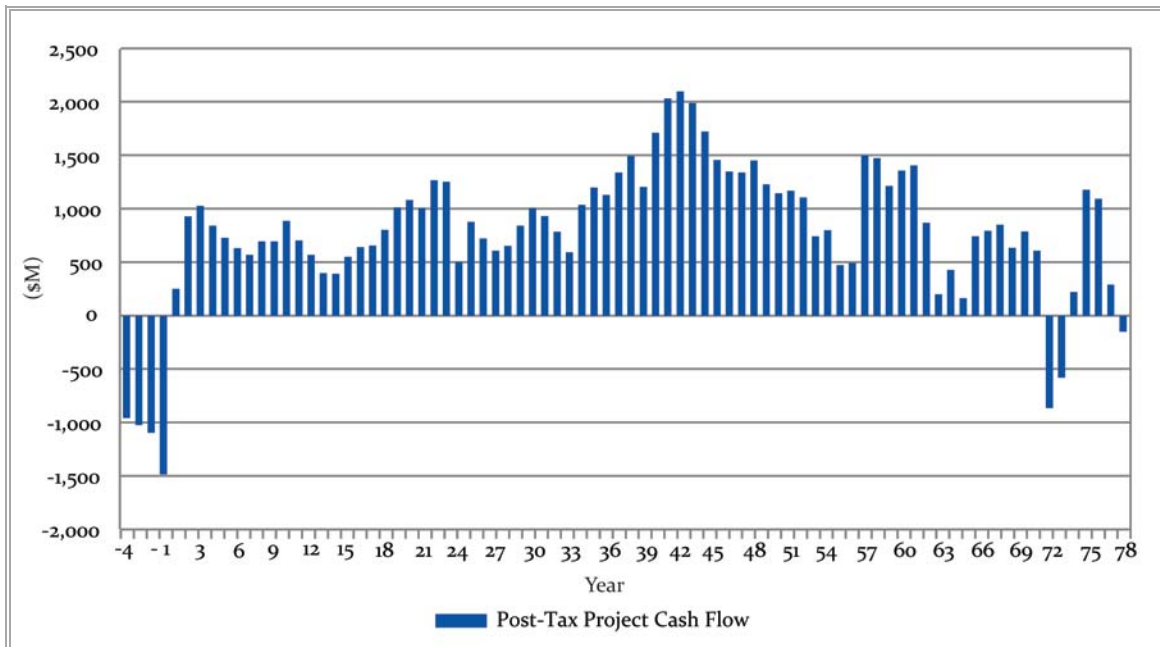
**Figure 18.8.15 Revenue vs. Operating Costs – 78-year Resource Case**



CASH FLOW

Figure 18.8.16 illustrates the annual project post-tax cash flows for the 78-year Resource Case.

**Figure 18.8.16 Project Post-tax Cash Flow – 78-year Resource Case (\$M)**



SENSITIVITY ANALYSIS

Sensitivity analyses have been carried out on the following parameters:

- copper, gold and molybdenum prices;
- initial capital expenditure; and
- mine site operating costs.

The analyses are presented graphically as financial outcomes in terms of NPV<sub>7</sub> and IRR (Figure 18.8.17 and Figure 18.8.18). The project pre-tax NPV (7% discount) is most sensitive to metal prices, operating costs, and capital costs in decreasing order.

METAL PRICE MATRICES

Table 18.8.42 to Table 18.8.45 illustrate the 78-year Resource Case’s sensitivity to a range of copper and gold prices in both pre-tax and post-tax evaluations with other metal prices held constant. The NPV<sub>7</sub> matrices are shown in \$ billions.

Figure 18.8.17 Pre-Tax NPV<sub>7</sub> Sensitivity to Inputs – 78-year Resource Case

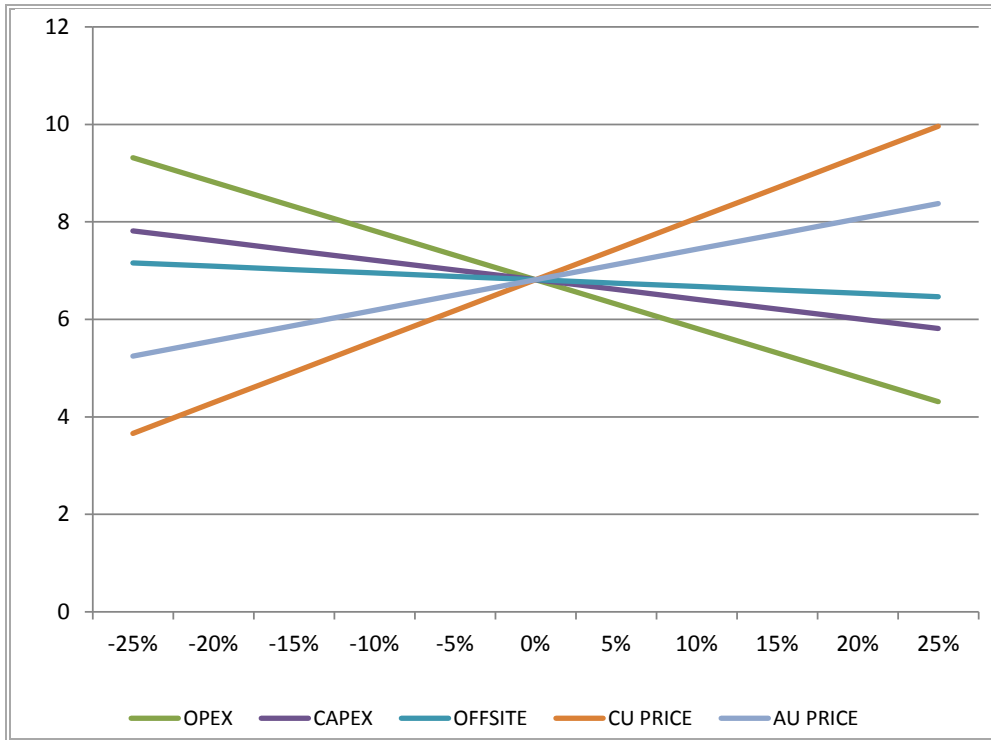
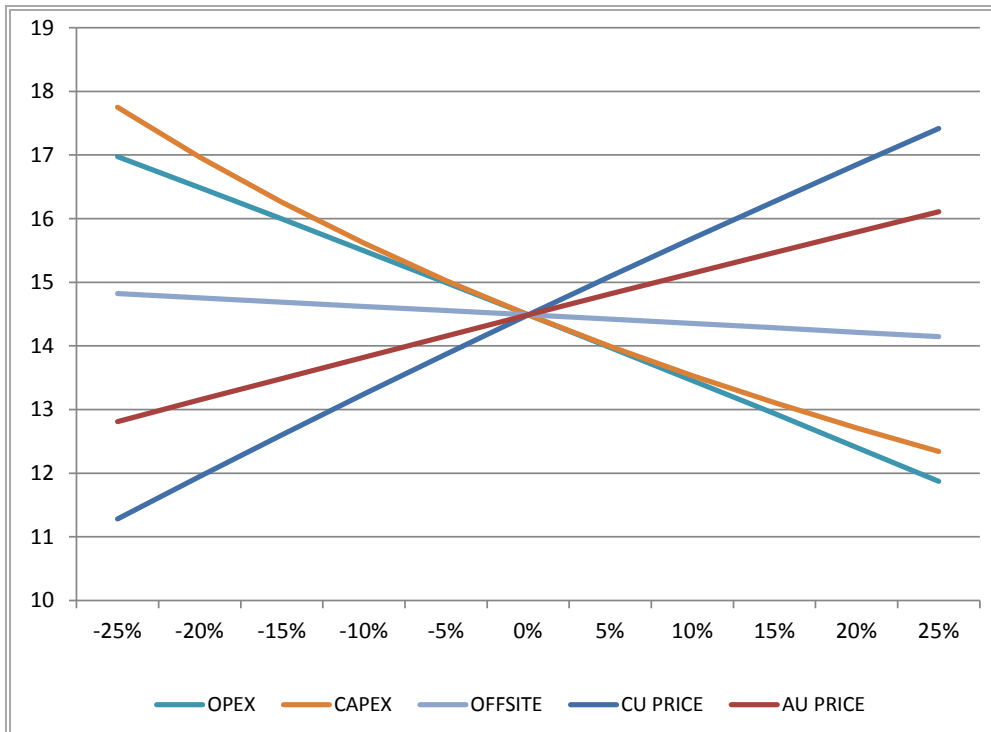


Figure 18.8.18 Pre-Tax IRR Chart Sensitivity to Inputs – 78-year Resource Case



**Table 18.8.42 Pre-Tax NPV<sub>7</sub> Metal Price Matrix – 78-year Resource Case**

Gold Price (\$/oz)	Copper Price (\$/lb)													
	2.00	2.25	2.50	2.75	3.00	3.25	3.50	3.75	4.00	4.25	4.50	4.75	5.00	
700	2.20	3.46	4.73	5.99	7.25	8.51	9.77	11.03	12.29	13.55	14.81	16.07	17.33	
750	2.50	3.76	5.02	6.28	7.55	8.81	10.07	11.33	12.59	13.85	15.11	16.37	17.63	
800	2.80	4.06	5.32	6.58	7.84	9.10	10.36	11.62	12.88	14.14	15.40	16.66	17.92	
850	3.10	4.36	5.62	6.88	8.14	9.40	10.66	11.92	13.18	14.44	15.70	16.96	18.22	
900	3.39	4.66	5.92	7.18	8.44	9.70	10.96	12.22	13.48	14.74	16.00	17.26	18.52	
950	3.69	4.96	6.22	7.48	8.74	10.00	11.26	12.52	13.78	15.04	16.30	17.56	18.82	
1000	3.99	5.25	6.51	7.77	9.03	10.29	11.56	12.82	14.08	15.34	16.60	17.86	19.12	
1050	4.29	5.55	6.81	8.07	9.33	10.59	11.85	13.11	14.37	15.63	16.89	18.15	19.41	
1100	4.59	5.85	7.11	8.37	9.63	10.89	12.15	13.41	14.67	15.93	17.19	18.45	19.71	
1150	4.89	6.15	7.41	8.67	9.93	11.19	12.45	13.71	14.97	16.23	17.49	18.75	20.01	
1200	5.19	6.45	7.71	8.97	10.23	11.49	12.75	14.01	15.27	16.53	17.79	19.05	20.31	
1250	5.48	6.74	8.00	9.26	10.52	11.79	13.05	14.31	15.57	16.83	18.09	19.35	20.61	
1300	5.78	7.04	8.30	9.56	10.82	12.08	13.34	14.60	15.86	17.12	18.38	19.64	20.90	
1350	6.08	7.34	8.60	9.86	11.12	12.38	13.64	14.90	16.16	17.42	18.68	19.94	21.20	
1400	6.38	7.64	8.90	10.16	11.42	12.68	13.94	15.20	16.46	17.72	18.98	20.24	21.50	
1450	6.68	7.94	9.20	10.46	11.72	12.98	14.24	15.50	16.76	18.02	19.28	20.54	21.80	
1500	6.97	8.23	9.49	10.75	12.01	13.27	14.53	15.79	17.06	18.32	19.58	20.84	22.10	

**Table 18.8.43 Pre-Tax IRR Metal Price Matrix – 78-year Resource Case**

Gold Price (\$/oz)	Copper Price (\$/lb)													
	2.00	2.25	2.50	2.75	3.00	3.25	3.50	3.75	4.00	4.25	4.50	4.75	5.00	
700	9.6%	10.9%	12.2%	13.5%	14.7%	15.9%	17.1%	18.2%	19.3%	20.3%	21.3%	22.4%	23.3%	
750	9.9%	11.3%	12.6%	13.8%	15.0%	16.2%	17.3%	18.5%	19.5%	20.6%	21.6%	22.6%	23.6%	
800	10.3%	11.6%	12.9%	14.1%	15.3%	16.5%	17.6%	18.7%	19.8%	20.9%	21.9%	22.9%	23.8%	
850	10.6%	11.9%	13.2%	14.5%	15.6%	16.8%	17.9%	19.0%	20.1%	21.1%	22.1%	23.1%	24.1%	
900	10.9%	12.3%	13.5%	14.8%	16.0%	17.1%	18.2%	19.3%	20.4%	21.4%	22.4%	23.4%	24.3%	
950	11.3%	12.6%	13.9%	15.1%	16.3%	17.4%	18.5%	19.6%	20.6%	21.7%	22.7%	23.6%	24.6%	
1000	11.6%	12.9%	14.2%	15.4%	16.6%	17.7%	18.8%	19.9%	20.9%	21.9%	22.9%	23.9%	24.8%	
1050	12.0%	13.2%	14.5%	15.7%	16.8%	18.0%	19.1%	20.1%	21.2%	22.2%	23.2%	24.1%	25.1%	
1100	12.3%	13.6%	14.8%	16.0%	17.1%	18.3%	19.4%	20.4%	21.4%	22.4%	23.4%	24.4%	25.3%	
1150	12.6%	13.9%	15.1%	16.3%	17.4%	18.6%	19.6%	20.7%	21.7%	22.7%	23.7%	24.6%	25.6%	
1200	12.9%	14.2%	15.4%	16.6%	17.7%	18.8%	19.9%	21.0%	22.0%	23.0%	23.9%	24.9%	25.8%	
1250	13.3%	14.5%	15.7%	16.9%	18.0%	19.1%	20.2%	21.2%	22.2%	23.2%	24.2%	25.1%	26.1%	
1300	13.6%	14.8%	16.0%	17.2%	18.3%	19.4%	20.5%	21.5%	22.5%	23.5%	24.4%	25.4%	26.3%	
1350	13.9%	15.2%	16.3%	17.5%	18.6%	19.7%	20.7%	21.8%	22.8%	23.7%	24.7%	25.6%	26.5%	
1400	14.2%	15.5%	16.6%	17.8%	18.9%	20.0%	21.0%	22.0%	23.0%	24.0%	24.9%	25.9%	26.8%	
1450	14.6%	15.8%	16.9%	18.1%	19.2%	20.2%	21.3%	22.3%	23.3%	24.2%	25.2%	26.1%	27.0%	
1500	14.9%	16.1%	17.2%	18.4%	19.4%	20.5%	21.5%	22.5%	23.5%	24.5%	25.4%	26.3%	27.2%	

**Table 18.8.44 Post-Tax NPV<sub>7</sub> Metal Price Matrix – 78-year Resource Case**

Gold Price (\$/oz)	Copper Price (\$/lb)												
	2.00	2.25	2.50	2.75	3.00	3.25	3.50	3.75	4.00	4.25	4.50	4.75	5.00
700	1.22	2.20	3.16	4.10	5.03	5.94	6.85	7.75	8.63	9.50	10.36	11.21	12.05
750	1.45	2.43	3.38	4.33	5.25	6.16	7.06	7.96	8.84	9.70	10.56	11.41	12.25
800	1.69	2.66	3.61	4.55	5.47	6.38	7.28	8.17	9.04	9.91	10.77	11.61	12.45
850	1.92	2.88	3.83	4.77	5.68	6.59	7.49	8.38	9.25	10.11	10.97	11.81	12.65
900	2.15	3.11	4.05	4.99	5.90	6.81	7.71	8.59	9.45	10.32	11.17	12.01	12.85
950	2.38	3.34	4.28	5.20	6.12	7.02	7.92	8.79	9.66	10.52	11.37	12.21	13.05
1000	2.61	3.56	4.50	5.42	6.33	7.24	8.13	9.00	9.86	10.72	11.57	12.41	13.25
1050	2.84	3.78	4.72	5.64	6.55	7.45	8.34	9.21	10.07	10.92	11.77	12.61	13.45
1100	3.06	4.01	4.94	5.85	6.76	7.67	8.54	9.41	10.27	11.12	11.97	12.81	13.65
1150	3.29	4.23	5.16	6.07	6.98	7.88	8.75	9.62	10.48	11.32	12.17	13.01	13.84
1200	3.51	4.45	5.38	6.29	7.19	8.08	8.96	9.82	10.68	11.52	12.37	13.21	14.04
1250	3.73	4.67	5.59	6.50	7.41	8.29	9.16	10.03	10.88	11.72	12.57	13.41	14.24
1300	3.96	4.89	5.81	6.72	7.62	8.50	9.37	10.23	11.08	11.92	12.77	13.60	14.44
1350	4.18	5.11	6.03	6.94	7.83	8.71	9.57	10.44	11.28	12.12	12.97	13.80	14.64
1400	4.40	5.33	6.24	7.15	8.04	8.91	9.78	10.64	11.48	12.32	13.16	14.00	14.84
1450	4.63	5.55	6.46	7.37	8.25	9.12	9.99	10.84	11.68	12.52	13.36	14.20	15.04
1500	4.85	5.77	6.68	7.58	8.46	9.33	10.19	11.04	11.88	12.72	13.56	14.40	15.23

**Table 18.8.45 Post-Tax IRR Metal Price Matrix – 78-year Resource Case**

Gold Price (\$/oz)	Copper Price (\$/lb)												
	2.00	2.25	2.50	2.75	3.00	3.25	3.50	3.75	4.00	4.25	4.50	4.75	5.00
700	8.6%	9.8%	11.0%	12.1%	13.2%	14.2%	15.1%	16.1%	17.0%	17.9%	18.7%	19.6%	20.4%
750	8.9%	10.1%	11.3%	12.4%	13.4%	14.4%	15.4%	16.3%	17.2%	18.1%	19.0%	19.8%	20.6%
800	9.2%	10.4%	11.6%	12.6%	13.7%	14.7%	15.6%	16.6%	17.5%	18.3%	19.2%	20.0%	20.8%
850	9.5%	10.7%	11.8%	12.9%	13.9%	14.9%	15.9%	16.8%	17.7%	18.5%	19.4%	20.2%	21.0%
900	9.8%	11.0%	12.1%	13.2%	14.2%	15.2%	16.1%	17.0%	17.9%	18.8%	19.6%	20.4%	21.2%
950	10.1%	11.3%	12.4%	13.4%	14.4%	15.4%	16.4%	17.3%	18.1%	19.0%	19.8%	20.6%	21.4%
1000	10.4%	11.6%	12.7%	13.7%	14.7%	15.7%	16.6%	17.5%	18.4%	19.2%	20.0%	20.8%	21.6%
1050	10.7%	11.9%	12.9%	14.0%	15.0%	15.9%	16.8%	17.7%	18.6%	19.4%	20.2%	21.0%	21.8%
1100	11.0%	12.1%	13.2%	14.2%	15.2%	16.2%	17.1%	17.9%	18.8%	19.6%	20.4%	21.2%	22.0%
1150	11.3%	12.4%	13.5%	14.5%	15.5%	16.4%	17.3%	18.2%	19.0%	19.8%	20.6%	21.4%	22.2%
1200	11.6%	12.7%	13.7%	14.7%	15.7%	16.6%	17.5%	18.4%	19.2%	20.1%	20.8%	21.6%	22.4%
1250	11.9%	13.0%	14.0%	15.0%	15.9%	16.9%	17.8%	18.6%	19.5%	20.3%	21.0%	21.8%	22.6%
1300	12.2%	13.2%	14.2%	15.2%	16.2%	17.1%	18.0%	18.8%	19.7%	20.5%	21.2%	22.0%	22.8%
1350	12.4%	13.5%	14.5%	15.5%	16.4%	17.3%	18.2%	19.1%	19.9%	20.7%	21.4%	22.2%	22.9%
1400	12.7%	13.8%	14.8%	15.7%	16.7%	17.6%	18.4%	19.3%	20.1%	20.9%	21.6%	22.4%	23.1%
1450	13.0%	14.0%	15.0%	16.0%	16.9%	17.8%	18.7%	19.5%	20.3%	21.1%	21.8%	22.6%	23.3%
1500	13.3%	14.3%	15.3%	16.2%	17.1%	18.0%	18.9%	19.7%	20.5%	21.3%	22.0%	22.8%	23.5%



**Table 18.8.46 Pebble Project Summary by Time Periods at Long-Term Metal Prices – 78-Year Resource Case**

Description	Unit	Total	Year - 4 to -1	Year 1 to 5	Year 6 to 10	Year 11 to 25	Year 26 to 45	Year 46 to 60	Year 61 to 78
Tonnes Milled	M ton	<b>6,528</b>	-	333	365	1,291	1,772	1,291	1,474
Strip Ratio		<b>2.6</b>	-	1.0	1.3	2.8	2.0	1.3	5.2
Copper Grade	%	<b>0.47%</b>	-	0.36	0.34	0.38	0.55	0.48	0.47
Au Grade	oz/ton	<b>0.0108</b>	-	0.0112	0.0107	0.0118	0.0110	0.0106	0.0095
Mo Grade	ppm	<b>243.0</b>	-	171.1	158.8	183.5	242.3	267.9	301.8
Cu Recovery	%	<b>88%</b>	-	82	86	87	89	89	89
Au Recovery	%	<b>71%</b>	-	70	70	72	71	71	71
Mo Recovery	%	<b>89%</b>	-	79	82	85	90	91	91
26% Cu-Au Concentrate	DMT	<b>93,225</b>	-	3,454	3,752	15,025	30,176	19,397	21,421
52% Mo Concentrate	DMT	<b>2,473</b>	-	80	83	360	681	555	713
Cu Eq lbs	Mlb	<b>96,357</b>	-	3,773	4,041	16,382	29,223	20,190	22,748
Cu lbs	Mlb	<b>53,437</b>	-	1,980	2,151	8,613	17,297	11,118	12,278
Au oz	k oz	<b>50,133</b>	-	2,614	2,747	11,069	13,929	9,817	9,957
Mo lbs	Mlb	<b>2,835</b>	-	92	96	413	780	637	818
Revenue	\$M	<b>233,908</b>	-	9,149	9,798	39,743	70,866	49,041	55,312
Realization Charges	\$M	<b>19,938</b>	-	725	781	3,165	6,229	4,214	4,823
NSR	\$M	<b>213,970</b>	-	8,424	9,016	36,578	64,637	44,826	50,489
NSR / Ton Milled	\$/ton	<b>32.8</b>	-	25.4	24.5	28.0	36.4	34.5	34.1
Operating Cost	\$M	<b>96,063</b>	269	3,339	3,614	15,073	23,606	16,296	33,866
Operating Cost / Ton Milled	\$/ton	<b>14.7</b>	-	10.1	9.9	11.7	13.4	12.7	23.2
Operating Profit	\$M	<b>117,906</b>	-269	5,085	5,403	21,505	41,030	28,530	16,622
Initial Capital	\$M	<b>4,695</b>	4,565	130	-	-	-	-	-
Sustaining Capital	\$M	<b>11,727</b>	-	326	520	3,261	2,721	1,726	3,172
Net Cash Flow After Tax	\$M	<b>64,328</b>	-4,662	3,777	3,475	11,708	24,537	16,830	8,663

**Table 18.8.47 Pebble Project Cumulative Summary at Long-term Metal Prices – 78-Year Resource Case**

Description	Unit	Total	Year - 4 to -1	Year 1 to 5	Year 1 to 10	Year 1 to 25	Year 1 to 45	Year 1 to 60	Year 1 to 78
Tonnes Milled	M ton	<b>6,528</b>	-	333	699	1,990	3,762	5,054	6,528
Strip Ratio		<b>2.6</b>	-	1.0	1.1	2.1	2.1	1.9	2.6
Copper Grade	%	<b>0.46%</b>	-	0.36%	0.35%	0.37%	0.45%	0.46%	0.46%
Au Grade	oz/ ton	<b>0.0108</b>	-	0.0112	0.0109	0.0115	0.0112	0.0111	0.0108
Mo Grade	ppm	<b>243.0</b>	-	171.1	164.9	176.1	205.5	221.1	243.0
Cu Recovery	%	<b>88%</b>	-	82%	84%	86%	87%	88%	88%
Au Recovery	%	<b>71%</b>	-	70%	70%	71%	71%	71%	71%
Mo Recovery	%	<b>89%</b>	-	79%	80%	83%	86%	88%	89%
26% Cu-Au Concentrate	DMT	<b>93,225</b>	-	3,454	7,206	22,231	52,408	71,805	93,225
52% Mo Concentrate	DMT	<b>2,473</b>	-	80	163	524	1,204	1,760	2,473
CuEq lb	Mlb	<b>96,357</b>	-	3,773	7,814	24,196	53,419	73,609	96,357
Cu lb	Mlb	<b>53,437</b>	-	1,980	4,131	12,743	30,040	41,159	53,437
Au oz	k oz	<b>50,133</b>	-	2,614	5,362	16,431	30,359	40,176	50,133
Mo lbs	Mlb	<b>2,835</b>	-	92	187	600	1,381	2,017	2,835
Revenue	\$M	<b>233,908</b>	-	9,149	18,946	58,690	129,556	178,596	233,908
Realization Charges	\$M	<b>19,938</b>	-	725	1,506	4,671	10,901	15,115	19,938
NSR	\$M	<b>213,970</b>	-	8,424	17,440	54,018	118,655	163,481	213,970
NSR / Ton Milled	\$/ton	<b>32.8</b>	-	25.4	24.9	26.8	31.1	31.9	32.8
Operating Cost	\$M	<b>96,063</b>	269	3,608	7,222	22,295	45,901	62,197	96,063
Operating Cost / Ton Milled	\$/ton	<b>14.7</b>	-	10.1	10.0	11.0	12.1	12.2	14.7
Operating Profit	\$M	<b>117,906</b>	-269	4,816	10,219	31,723	72,754	101,284	117,906
Initial Capital	\$M	<b>4,695</b>	4,565	4,695	4,695	4,695	4,695	4,695	4,695
Sustaining Capital	\$M	<b>11,727</b>		326	846	4,107	6,828	8,555	11,727
Net Cash Flow After Tax	\$M	<b>64,328</b>	-4,662	-885	2,590	14,297	38,835	55,664	64,328

**Table 18.8.48 Pebble Project Summary by Time Periods at Current Prevailing Prices – 78-Year Resource Case**

Description	Unit	Total	Year - 4 to -1	Year 1 to 5	Year 6 to 10	Year 11 to 25	Year 26 to 45	Year 46 to 60	Year 61 to 78
Revenue	\$M	<b>333,025</b>	-	13,053	14,009	56,566	101,993	69,539	77,865
Realization Charges	\$M	<b>19,957</b>	-	725	782	3,169	6,235	4,218	4,827
NSR	\$M	<b>313,068</b>	-	12,328	13,226	53,398	95,758	65,321	73,037
NSR / Ton Milled	\$/ton	<b>48.0</b>	-	37.2	35.9	40.9	53.9	50.2	49.3
Operating Cost	\$M	<b>96,063</b>	269	3,339	3,614	15,073	23,606	16,296	33,866
Operating Cost / Ton Milled	\$/ton	<b>14.7</b>	-	10.1	9.9	11.7	13.4	12.7	23.2
Operating Profit	\$M	<b>217,004</b>	-269	8,989	9,613	38,325	72,151	49,025	39,171
Initial Capital	\$M	<b>4,695</b>	4,565	130	-	-	-	-	-
Sustaining Capital	\$M	<b>11,727</b>	-	326	520	3,261	2,721	1,726	3,172
Net Cash Flow After Tax	\$M	<b>123,473</b>	-4,662	6,531	6,099	21,823	42,093	28,266	23,324

**Table 18.8.49 Pebble Project Cumulative Summary at Current Prevailing Metal Prices – 78-Year Resource Case**

Description	Unit	Total	Year - 4 to -1	Year 1 to 5	Year 1 to 10	Year 1 to 25	Year 1 to 45	Year 1 to 60	Year 1 to 78
Revenue	\$M	<b>333,025</b>	-	13,053	27,062	83,628	185,621	255,160	333,025
Realization Charges	\$M	<b>19,957</b>	-	725	1,508	4,676	10,912	15,130	19,957
NSR	\$M	<b>313,068</b>	-	12,328	25,554	78,952	174,710	240,030	313,068
NSR / Ton Milled	\$/ton	<b>48.0</b>	-	37.2	36.5	39.2	45.7	46.9	48.0
Operating Cost	\$M	<b>96,063</b>	269	3,608	7,222	22,295	45,901	62,197	96,063
Operating Cost / Ton Milled	\$/ton	<b>14.7</b>	-	10.1	10.0	11.0	12.1	12.2	14.7
Operating Profit	\$M	<b>217,004</b>	-269	8,720	18,332	56,657	128,808	177,833	217,004
Initial Capital	\$M	<b>4,695</b>	4,565	4,695	4,695	4,695	4,695	4,695	4,695
Sustaining Capital	\$M	<b>11,727</b>	-	326	846	4,107	6,828	8,555	11,727
Net Cash Flow After Tax	\$M	<b>123,473</b>	-4,662	1,869	7,968	29,790	71,883	100,149	123,473



## 19.0 INTERPRETATION AND CONCLUSIONS

---

The Pebble Project is a world-class, long-life, mineral development project of strategic global importance. As presented in this Preliminary Assessment, project economics are robust and support a mine development that is both technically feasible and permissible under existing regulatory standards in Alaska. The Pebble Project is being designed to achieve international best practice standards of design and performance, such that key environmental and cultural values are protected and meaningful development benefits accrue to local communities, the State of Alaska and the United States of America.

The Pebble deposit is located on state-owned land in southwest Alaska that has been subject to two comprehensive land-use planning exercises, and subsequently designated for mineral exploration and development. As a jurisdiction, Alaska has a long history of responsible natural resource and mineral development, and environmental standards and permitting requirements that are stable, objective, rigorous and science-based.

Since 2004, comprehensive environmental and socioeconomic baseline studies have been undertaken at the Pebble Project, in addition to ongoing stakeholder engagement and community outreach. These studies have cost more than \$150 million to date, and resulted in an environmental and socioeconomic database whose comprehensiveness and depth is unprecedented in Alaska. The aggregated findings and analysis of these studies, along with the Pebble Partnership's ongoing, long-term engagement with project stakeholders and federal and state regulators, are significant corporate assets as it prepares the Pebble Project for permitting.

Geological understandings of the Pebble deposit and surrounding region are well advanced. Pebble is a calc-alkalic copper-gold-molybdenum porphyry deposit located in an accretive, convergent tectonic setting, and related to porphyritic stocks and sills of diorite to granodiorite composition. Chalcopyrite and, to a lesser degree, bornite-bearing veins comprise the vast majority of mineralization at Pebble. Geometallurgical studies have delineated five main material types at Pebble; each type shows similar copper, gold and molybdenum mineralogy and deportment.

The deposit extends from surface in the west to a depth of more than 5,577 ft on its eastern boundary over a horizontal distance of 2.4 miles; north to south, the deposit measures 1.5 miles. A wedge-like cover sequences of post-mineralized Tertiary volcanics and sedimentary rocks overly the eastern portion of the deposit, ranging in thickness from 0 to 1,800 ft. At its eastern margin, this cover sequence and the Pebble deposit is down-dropped by the north-northeast trending ZG<sub>1</sub> fault.

The most recent (February 2010) mineral resource estimate for the Pebble deposit is defined by core logging of 509 diamond drill holes. The total number of exploration, delineation, geotechnical, metallurgical and environmental holes drilled on the Pebble property since 1988 is 1,158, comprising 948,638 ft (289,145 m).

Since 2001, Northern Dynasty and subsequently the Pebble Partnership have maintained an effective QA/QC system consistent with industry best practice. Since 2004, the Pebble QA/QC has been overseen by independent specialist consultants providing ongoing monitoring, facility inspection and timely reporting of the performance of standards, blanks and duplicates in the drill hole sampling and analytical program. The results of this program indicate that analytical results are of a high quality suitable for use in detailed modeling and resource evaluation studies.

At a 0.30% CuEQ cut-off, the Pebble mineral resource comprises:

- 5.94 billion tonnes of Measured and Indicated Mineral Resources grading 0.78% CuEQ, containing 55 billion pounds of copper, 67 million ounces of gold, and 3.3 billion pounds of molybdenum; and
- 4.84 billion tonnes of Inferred Mineral Resources grading 0.53% CuEQ, containing 25.6 billion pounds of copper, 40.4 million ounces of gold, and 2.3 billion pounds of molybdenum.

It should be noted that Inferred mineral resources are considered to be too speculative to allow the application of technical and economic parameters to support mine planning and the evaluation of the economic viability of the project. As such, there is currently no certainty that development cases incorporating Inferred mineral resources can be realized.

The development cases presented in this Preliminary Assessment contemplate open pit mining of the Pebble deposit utilizing conventional drill, blast and truck-haul methods, with an initial mine life of 25 years and potential for mine life extensions to 78 years and beyond. Underground block caving remains a viable option for developing higher-grade resources in subsequent phases of mining, and will be further investigated during the initial 25 years of production. Phases of development beyond 25 years will require separate permitting and development decisions to be made in the future, based on prevailing conditions at the time and the accumulated experience gained from developing and operating the initial phase of the Pebble Project.

Reconnaissance of the Pebble property has identified a number of exploration targets, some of which have been tested and found to contain deposit-grade mineralization. Further exploration of these targets is warranted as they may provide significant opportunities to extend the mine life and expand production.

It should be noted that the project description the Pebble Partnership ultimately elects to submit for permitting under the US National Environmental Policy Act (NEPA) may differ from the development cases presented in this Preliminary Assessment. The Pebble Partnership continues to advance engineering and project design toward the completion of a Prefeasibility Study for the Pebble Project. This effort will be informed by input received from project stakeholders through public consultation forums undertaken in Alaska prior to the completion of a Prefeasibility Study and the submission of permit applications.

A process plant with nominal mill throughput of 200,000 tons per day, and depending on ore softness ranging up to 275,000 tons per day in some years of mining, will incorporate conventional crush-grind-float technology and equipment, with secondary gold recovery. Mine site facilities will be powered by a 378 MW combined-cycle natural-gas fired turbine plant at the mine site, fuelled by natural gas piped

from the Kenai Peninsula. Marketable products from this facility include a 26% copper-gold concentrate with gold, silver and palladium, a 52% molybdenum concentrate with rhenium, and gold doré.

Copper-gold concentrate will be pumped via pipeline to a permanent deep-sea port on Cook Inlet some 66 miles to the east for shipping to off-shore smelters. Molybdenum concentrate will be trucked along an 86-mile all-weather, permanent access road to the port site for shipment to an off-shore molybdenum autoclave plant. Gold doré will be transported by air from an existing aviation facility at Iliamna.

The three successive development cases presented in this Preliminary Assessment have a common capital cost of \$4.7 billion, and a 48-month execution schedule. This capital estimate excludes costs associated with port, road and power infrastructure, as it is planned that these project components will be developed through outsource relationships with third-parties.

The financial model presented in this Preliminary Assessment is based on long-term forecast metal prices of \$2.50 per pound of copper, \$1,050 per ounces of gold, \$13.50 per pound of molybdenum, \$15 per ounce of silver, \$3,000 per kilograms of rhenium and \$490 per ounce of palladium. Annual cash flows are calculated and subsequently discounted at a rate of 7% – a blend of the 8% rate commonly applied to copper and other base metal projects and the 5% rate commonly applied to gold and other precious metal projects. Smelting, refining and concentrate transport charges, fixed and variable operating costs, initial and sustaining capital costs, and annual recovered metal production, incorporating tonnage milled, head grades and recoveries, have been considered.

The suite of valuable metals contained in the Pebble deposit – copper, gold, molybdenum, silver, rhenium, palladium – not only enhance the project economics but will provide a level of cash flow protection during operations. During lower price cycle periods for some metals, the prices of other metals may be higher.

The 45-year Reference Case has been selected by Wardrop as the base case for this Preliminary Assessment. It achieves a NPV of \$6.1 billion, an IRR of 14.2% and a capital payback period of 6.2 years. Over 45 years, it will process 3.8 billion tons of ore and produce 30.5 billion pounds of copper, 30.3 million ounces of gold, 1.4 billion pounds of molybdenum, 140 million ounces of silver, 1.2 million kilograms of rhenium and 907,000 ounces of palladium.

The 25-year IDC Case achieves an NPV of \$3.8 billion, an IRR of 13.4% and a capital payback period of 6.5 years. Over 25 years, it will process 1.99 billion tons of ore and produce 12.9 billion pounds of copper, 16.4 million ounces of gold, 616 million pounds of molybdenum, 67.2 million ounces of silver, 502,000 kilograms of rhenium and 385,000 ounces of palladium.

The 78-year Resource Case achieves an NPV of \$6.8 billion, an IRR of 14.5% and a capital payback period of 6.1 years. Over 78 years, it will process 6.5 billion tonnes of ore and produce 53.4 billion lb of copper, 50.1 million ounces of gold, 2.8 billion pounds of molybdenum, 242 million ounces of silver, 2.3 million kilograms of rhenium and 1.59 million ounces of palladium.

In order to calculate an NPV and IRR for Northern Dynasty's 50% interest in the Pebble Project, Anglo American's funding requirement to retain its 50% interest must be considered. Assuming that \$1

billion of Anglo American's \$1.425 to \$1.5 billion funding requirements will be applied to the Pebble Project's capital cost for construction, the pre-tax economic valuation at long-term metal prices of Northern Dynasty's interest in each of the three development cases are summarized below:

- The 45-year Reference Case achieves an NPV of \$3.6 billion, an IRR of 18.0% and a capital payback period of 4.7 years for Northern Dynasty's interest.
- The 25-year IDC Case achieves an NPV of \$2.4 billion, an IRR of 17.3% and a capital payback period of 4.9 years for Northern Dynasty's interest.
- The 78-year Resource Case achieves an NPV of \$3.9 billion, and IRR of 18.4% and a capital payback period of 4.6 years for Northern Dynasty's interest.

Fixed and variable operating costs for open pit, tailings, process, G&A, environmental and transportation have been derived by discipline and applied annually to the mine plan tonnage for each of the three development cases. Total life-of-mine operating costs for the 45-year Reference Case are \$11.55 per ton milled.

The Pebble Project will generate significant direct and indirect employment, business/economic activity and government revenues in the Bristol Bay region, the State of Alaska and the United States. The Pebble Partnership has a stated intention to maximize project benefits for the residents and communities of southwest Alaska, and is developing long-term workforce and business development strategies to realize this goal.

A major part of this economic activity will be in the form of employment. The workforce will peak at 2,500 people during construction and will require approximately 20 million manhours of labour. During operations, approximately 1,000 people will be employed in high-paying jobs at a mine which has decades of life.

Transportation and energy infrastructure development associated with the Pebble Project also has the potential to deliver significant benefits for communities in southwest Alaska, by lowering the cost of living for local residents and supporting economic growth and diversification. Meaningful benefits associated with power generation and transmission, in particular, could be extended to communities throughout the Bristol Bay region.

Given the intensive technical, engineering, environmental, permitting and socioeconomic study programs undertaken in support of the Pebble Project since 2005, much of the analysis and supporting data in this Preliminary Assessment exceeds that often found in reports of this type, and approaches a pre-feasibility and (in some cases) feasibility level of detail.

This Preliminary Assessment has demonstrated robust economic results for the Pebble Project, but has also identified a long list of opportunities to further enhance the project value.



## 20.0 OPPORTUNITIES AND RECOMMENDATIONS

---

### 20.1 RESOURCE

---

The resources at Pebble continue to provide a number of opportunities.

#### 20.1.1 EASTERN EXTENSION

The mineralization surrounding the 1,000 ft high grade intersection in hole 6348 is still open. This represents a significant opportunity to expand the highest grade portion of the Pebble deposit at depth, to the east.

#### 20.1.2 ADDITIONAL DEPOSITS

A number of deposits have been identified on the property, including a higher grade gold zone. Additional low grade gold mineralization has been identified and a number of geophysical anomalies have yet to be tested. These exploration targets could further enhance the project by changing the gold production levels and by providing options for future project expansion.

#### 20.1.3 SILVER

A number of areas of the deposit have superior silver grades. The mine plan has not been optimized for silver and this should be assessed during the next phase of study.

### 20.2 MINING

---

#### 20.2.1 GENERAL

The Pebble deposit is very large, and even the 78-year Resource Case would exploit only 55% of the total resource. This deposit scale affords a number of opportunities over the long term to optimize the project over its life or to change the mine plan in response to short to medium term changes in markets or other factors. This would enable future mine planners to consider exploiting different parts of the deposit for higher grades of, for example, silver if the silver price is high; to evaluate production expansions; and to assess potential underground operations.

## 20.2.2 OPEN PIT

### PIT OPTIMIZATION

The open pit shells used in this study have been generated using parameters developed in early 2009. A number of these parameters (e.g. metal prices, operating costs) have seen significant improvement since that time. These changes may have a beneficial impact on the pit development sequence and should be incorporated into the pit optimization during the next study phase. The other optimization parameters should also be confirmed as part of this process.

### PIT WALL SLOPES

The Pebble Partnership has reviewed the impact of changes to the current pit wall slopes. The upper sections, through overburden and the immediately underlying frost-shattered bedrock, may have to be flattened. However, the rock sections, particularly those in the higher eastern walls, could be steepened from the current 39° slope to 41°.

Slope changes of this order could result in a net waste rock reduction in the 25-year IDC Case open pit by approximately 30 million tons. This benefit will be much greater in the 45-year Reference Case and 78-year Resource Case, both of which exploit more of the deeper ore to the east.

### OPTIMIZE PRODUCTION FORECAST

There is an extended period of low stripping beyond year 45 in the 78-year Resource Case, which indicates the sequencing of the 45-year open pit could be optimized by reducing the strip ratio leading into the mining of the later ore. Further, the value demonstrated by the 78-year Resource Case demonstrates that running the pit optimization over the life of the project may also further increase the project returns.

### AUTOMATION

The use of autonomous trucks has been shown to add significant value to the Pebble Project. Additional automation opportunities, such as blasthole drilling, would likely have analogous benefits.

## 20.2.3 UNDERGROUND

A potential underground mine has not been considered as a primary case in this study. Further assessment of this option is warranted to evaluate methodologies of enhancing relative economics of an underground mine and confirming its performance.

## 20.3 PROCESS

---

### 20.3.1 AUTOMATION

Plant automation may provide future opportunities.

### 20.3.2 SAG MILL SIZE

The current SAG mill size – 40 ft diameter – was selected because it was the largest mill currently in operation. However, a 42 ft diameter mill has recently been ordered for another project. The improved throughput from a larger mill diameter would further enhance the net present value of the project by a significant amount.

### 20.3.3 GOLD RECOVERY

Some other copper-gold porphyry projects report higher gold recoveries than the 71% currently projected for Pebble. Additional work should be undertaken to optimize gold recovery, as a 5% increase to 76% recovery would further enhance the NPV of the 45-Year Reference Case by \$300 million, based on the sensitivity analysis.

Gold recoveries would be increased by reducing the copper-gold concentrate copper grade; trade-off analysis of this opportunity should be conducted during the next phase of the study.

### 20.3.4 GRINDING CIRCUIT

In the current grinding circuit layout, crushed pebbles are returned to the SAG mill (SABC-A circuit). However, depending on the characteristics of the plant feed at a given time, this arrangement may underutilize the capacity of the mills. An analysis has been completed which shows the option of returning the crushed pebbles to the ball mills (SABC-B circuit) could increase mill throughput by 5% to 10%. A 5% improvement in throughput would increase the NPV of the 45-year Reference Case by \$600 million.

### 20.3.5 PRODUCTION INCREASE

The scale of the resource would enable processing of a much higher daily ore throughput; previous analysis has shown beneficial financial impacts of such expansions. Such results warrant further study as the project progresses through subsequent study phases.

## 20.4 INFRASTRUCTURE

---

### 20.4.1 PORT

Alternative port construction techniques should be evaluated, such as building the facility as caissons which could be towed to site and ballasted to the seafloor.

### 20.4.2 OTHER OUTSOURCING OPPORTUNITIES

In this Preliminary Assessment, only the three primary infrastructure components – access road, port and power generation – were considered for outsourcing to third party providers. However, a wide range of other opportunities exist, which could both improve the project economics and provide

additional opportunities for local businesses. Some of these were considered in the study, such as air transport to local villages, but others include:

- concentrate and water return pipelines;
- mine and port site accommodations facilities;
- freight transport between Port Site 1 and the mine site;
- local transportation, at the mine site and between the mine site and local villages;
- turn-key fuel supply; and
- mine equipment maintenance.

These opportunities should be further examined during subsequent study phases.

## **20.5 PROJECT EXECUTION AND OPERATION**

---

### **20.5.1 DEVELOPMENT SCHEDULE**

Under the current schedule project construction would require four years. A number of options, such as enhancing early mobilization, should be explored to identify potential opportunities for reducing this period. In addition, although the cost improvement for modularization was included in the project capital cost, the schedule improvements were not. This should be corrected in the next round of study, as a one year schedule reduction could further increase the NPV 45-year Reference Case by \$400 million.

### **20.5.2 CONSTRUCTION CASH FLOW**

A significant opportunity to improve project NPV exists by optimizing the cash flow during project implementation. This should be further evaluated during the next phase of study.

### **20.5.3 RAMP-UP**

The production plan utilizes standard McNulty Curve ramp-up targets for the process plant, resulting in an 18 month period from initial to full production. This has a significant impact on project NPV and thus identifying options for improving ramp-up will provide superior results.

### **20.5.4 SUSTAINING CAPITAL**

The level of sustaining capital, particularly in later mine life years, should be evaluated to confirm it is required. In particular, the mining equipment life cycle seems conservative and should be re-evaluated to ensure it meets current North American operating standards.

## 20.6 COSTS

---

### 20.6.1 COST ESCALATION

Many of the costs were derived or were estimated on the basis of information collected in 2008, which was a period of hyper inflation. Further analysis should be conducted during the next level of study to determine if additional savings are possible as it is possible that substantial cost reductions could be realized through an updated analysis.

### 20.6.2 CONTINGENCY

The capital cost contingency level of 17.7% is appropriate for a concept-level study. However, much of the engineering to support this study was done at a level superior to a concept-level study and in a number of instances approaches prefeasibility accuracy. For the 45-year Reference Case, each reduction of 1% in the contingency estimate results in a \$42 million increase in the Pebble Project's pre-tax NPV<sub>7</sub>. During the next phase of study, particular attention should be paid to ensuring the contingency level matches the accuracy of the estimate.

### 20.6.3 CAPITAL COST

Wardrop has reviewed the methodology used to develop the capital cost estimate and believes, based on their experience, certain costs may have been overestimated. Wardrop completed a preliminary, high-level estimate of the likely range of capital cost outcomes and a savings of some \$362 million from the current capital cost estimate was identified. A capital cost reduction of \$362 million would result in a 0.8% improvement in the pre-tax IRR for the Pebble project to 15%, and a \$313 million improvement in pre-tax NPV<sub>7</sub> to \$6,442 million. For Northern Dynasty, such a capital cost reduction for the project would result in an increase in its post-tax IRR of 1.3% to 16.7%, and an increase of \$128 million in its post-tax NPV<sub>7</sub> to \$2,486 million. As the project develops through subsequent phases Wardrop anticipates that further cost savings are possible through engineering optimization.

### 20.6.4 POWER

The power cost of \$0.066/kWh was based on a natural gas price of \$7/mcf, which is considerably above the current price of approximately \$4/mcf. This gas price should receive particular attention during the next phase of study, as the power cost almost directly correlates to the natural gas price.

## 20.7 FINANCIAL ANALYSIS

---

### 20.7.1 REAL OPTIONS

The financial analysis was conducted using classic discounted cash flow techniques. These techniques demonstratively penalize long-life projects, which is enhanced in Pebble's case due to its very long life. Alternate techniques, such as Real Options, are available and in many instances in project assessments have shown the actual project results are likely to be much better than projected by discounted flows.

A Real Options analysis should be conducted during the next phase of study to determine the extent to which the discounted cash flow treatment of uncertainty may be artificially understating the value of Pebble.

#### **20.7.2     PRECIOUS METAL STREAMING**

Many recently announced projects have included pre-sales of portions of their precious metal streams. Preliminary analysis of this option has shown that, under the correct circumstances, such pre-sales could add substantial economic value to the project. Precious metal financing strategies should be further studied during the next phase of the project.

## 21.0 REFERENCES

---

### 21.1 GEOLOGY

---

1. Detterman, R.L., and Reed, B.L., 1973. Surficial Deposits of the Iliamna Quadrangle, Alaska, U.S. Geological Survey Bulletin 1368-A, 64 p.
2. Hart CJR, 2010. Intrusive rocks associated with the Pebble porphyry Cu-Au-Mo deposit, southwest Alaska. GSA Denver annual meeting abstract 182738.
3. Rebagliati. C.M. and Haslinger, R.J., 2003. Technical Report on the Pebble Project January 2003.
4. Rebagliati. C.M. and Haslinger, R.J., 2004. Technical Report on the Pebble. January 2004.
5. Rebagliati. C.M. and Haslinger, R.J., Payne, J.G., and Price, C.M., 2004. Technical Report on the Pebble Project. May 2004.
6. Rebagliati. C.M. and Payne, J.G., 2005. Technical Report on the Pebble Project March 2005.
7. Rebagliati. C.M. and Payne, J.G., 2006. Technical Report on the Pebble Project. March 2006.
8. Rebagliati. C.M. and Payne, J.G., 2007. 2006 Summary Report on the Pebble Porphyry Copper-Gold-Molybdenum Project. Iliamna Lake Area, Southwestern Alaska, USA. March 2007. 119 pages.
9. Rebagliati. C.M., Lang, J.R., Titley, E., Gaunt, J.D., Rennie, D., Melis, L., Barratt, D., Hodgson, S., 2008. Technical Report on the 2007 Program and Updates on Metallurgy and Resources. March 2008.
10. Rebagliati. C.M., Lang, J.R., Titley, E., Gaunt, J.D., Rennie, D., Melis, L., Barratt, D., Hodgson, S., 2009. Technical Report on the 2008 Program and Updates on Mineral Resources and Metallurgy. February, 2009.
11. Rebagliati. C.M., Lang, J.R., Titley, E., Gaunt, J.D., Melis, L., Barratt, D., Hodgson, S., 2010. Technical Report on the 2009 Program and Update on Mineral Resources and Metallurgy. Pebble Copper-Gold-Molybdenum Project, Iliamna Lake Area, Southwestern Alaska, USA for Northern Dynasty Minerals Ltd. March, 2010. 194 pages.
12. Wallace WK, Hanks CL and JF Rogers, 1989. The southern Kahiltna terrane: Implications for the tectonic evolution of southwestern Alaska. GSA Bulletin 101, 1389-1407.

#### WEBSITES

SEDAR (System for Electronic Document Analysis and Retrieval): [www.sedar.com](http://www.sedar.com)

## 21.2 MINERAL PROCESSING

---

1. AMEC Americas Ltd., 2010. HPGR Option- Scoping Level Assessment. Project N°: 162870. June 10, 2010.
2. AMEC, Americas Ltd., 2009. Pebble 2009 Concept Study; Coarse Ore Storage Trade-off Study. October 30, 2009.
3. Contract Support Service Inc., 2010. Final Report, Pebble Life of Mine Simulations – Years 1 to 25, SABC-A vs. SABC-B Circuit Options; April 29, 2010.
4. Contract Support Service Inc., 2010. Summary of Results Effect of Feed Size, Years 1 and 8; SABC-A vs. SABC-B Circuit Options; April 7, 2010.
5. Contract Support Service Inc., 2010. Summary of Results Pebble Life of Mine Simulations – Years 1 to 13; SABC-A vs. SABC-B Circuit Options; April 7, 2010.
6. DJB Consultants Inc., 2010. Throughput Estimates Based on Mine Plan, and revisions; Project 0055-66 Pebble, March 25, 2010.
7. FL Smidth Minerals, 2010. Grinding Circuit Comments, Private Communication, November 6, 2010.
8. FL Smidth Minerals, 2010. Large Flotation Cell Comments, Private Communication, November 5, 2010.
9. Metso Minerals Canada Inc., 2010. Grinding Circuit Comments, Private Communication, December 3, 2010.
10. Outotec (Canada) Ltd., 2010. Outotec Thickener Interpretations and Recommendations for Test Data. Report TH-0493, Pebble Project, April 9, 2010.
11. Outotec (Canada) Ltd., 2010. Outotec Thickener Interpretations and Recommendations for Test Data. Report TH-0497, Pebble Project. June 17, 2010.
12. Outotec (Canada) Ltd., 2010. Tank Cells CM500 Comments, Private Verbal Communication, November 2010.
13. Outotec Oyj, 2010. Tankcell e500, Mechanical Testwork. March 11, 2010.
14. SGS-Lakefield Research Ltd., 2010. An Investigation into the Pebble East and Pebble West Metallurgical Programs. Project #12072-002 Final Report, May 3, 2010.
15. SGS-Lakefield Research Ltd., 2010. An Investigation into the Recovery of Copper, Gold, and Molybdenum from Samples from Pebble East and West Deposits. Project #12072-002-Report #2, May 10, 2010.



## 21.3 TAILINGS

---

1. Knight & Piésold, 2009A.
2. Pebble Project Geochemical Characterization Presentation, SRK Consulting, 28 November 2006.

## 21.4 MINING

---

1. Knight Piésold, 2005. “Geotechnical Site Investigation Data Report” (Ref. No. VA101-176/8-3) March 2005.
2. Knight Piésold, 2007. “2005 Geotechnical Site Investigation Data Report” (Ref. No. VA101-176/8-6) March 2007.
3. Knight Piésold, 2008. “2006 Geotechnical Site Investigation Data Report” (Ref. No. VA101-176/8-9) March 2008.
4. Knight Piésold, 2008. “2007 Geotechnical Site Investigation Data Report” (Ref. No. VA101-176/20-4) November 2008.
5. Knight Piésold, 2009. “2008 Geotechnical Site Investigation Data Report” (Ref. No. VA101-176/23-4) October 2009.
6. NCL Ingenieria y Construcción S.A., 2005. 2004 Open Pit Geotechnical Investigations – Vol. I Draft Report. January 17, 2005.
7. NCL Ingenieria y Construcción S.A., 2009. Open Pit Mine Desktop Studies of the Pebble Copper-Gold Project. September 2009.
8. CWA ,2010. Bulk Material Handling system for In Pit Crushing, April 16, 2010.
9. CWA, 2010. Pebble Mine – In Pit Crush Convey System, Preliminary IPCC Preliminary OPEX and CAPEX Summary Memorandum No. 002, April 9, 2010.
10. Hatch – November 2009 – noted in the Pebble Partnership’s Value Seeking Phase (VSP) Report 2009 - Vol. 2 Section 03 Underground FMR July 23.pdf (pp 3-2).
11. BAE – noted in the Pebble Partnership’s Value Seeking Phase (VSP) Report 2009 – Vol. 2 Section 03 Underground FMR July 23.pdf (pp 3-14).
12. SRK, 2008. Pebble Project – 2007 Geotechnical Data Acquisition Program – Pebble East Zone Data Report, March 2008.
13. Stantec: “Pebble East 150 ktpd 2010 Order of Magnitude Evaluation”, dated 8 June 2010.

## 21.5 ADDED BY CLIENT

---

1. John, D.A., Ayuso, R.A., Barton, M.D., Blakely, R.J., Bodnar, R.J., Dilles, J.H., Gray, F., Graybeal, F.T., Mars, J.C., McPhee, D.K., Seal, R.R., Taylor, R.D., and Vikre, P.G., 2010, Porphyry copper deposit model, chapter B of Mineral deposit models for resource assessment: U.S. Geological Survey Scientific Investigations Report 2010-5070-B, 169 p.

## 22.0 DATE AND SIGNATURE PAGE

---

The effective date of this Technical Report, titled “Preliminary Assessment of the Pebble Project, Southwest Alaska”, is February 15, 2011.

Signed,

*“signed and sealed”*

---

Hassan Ghaffari, P.Eng.  
Manager of Metallurgy  
Wardrop Engineering Inc.

*“signed and sealed”*

---

Dr. Robert Sinclair Morrison, P.Geo.  
Lead Resource Geologist  
Wardrop Engineering Inc.

*“signed and sealed”*

---

Marinus Andre de Ruijter, P.Eng.  
Senior Metallurgical Engineer  
Wardrop Engineering Inc.

*“signed and sealed”*

---

Aleksandar Zivkovic, P.Eng.  
Manager, Geotechnical Engineering  
Wardrop Engineering Inc.

*“signed and sealed”*

---

Tysen Hantelmann, P.Eng.  
Senior Mining Engineer  
Wardrop Engineering Inc.

*“signed and sealed”*

---

Douglas Ramsey, R.P.Bio. (BC)  
Manager, Environmental Assessment,  
Permitting, and Natural Resources  
Wardrop Engineering Inc.

*“signed and sealed”*

---

Scott Cowie, MAusIMM  
Study Manager  
Wardrop Engineering Inc.

# CERTIFICATE OF QUALIFIED PERSON

---

I, Hassan Ghaffari, of Vancouver, BC, do hereby certify:

- I am a Manager of Metallurgy with Wardrop Engineering Inc. with a business address at #800 – 555 West Hastings Street, Vancouver, British Columbia.
- This certificate applies to the technical report entitled “Preliminary Assessment of the Pebble Project, Southwest Alaska”, dated February 17, 2011 (the “Technical Report”).
- I am a graduate of the University of Tehran (M.A.Sc., Mining Engineering, 1998) and the University of British Columbia (M.A.Sc., Mineral Process Engineering, 2004).
- I am a member in good standing of the Association of Professional Engineers and Geoscientists of the Province of British Columbia (#30408).
- My relevant experience includes 23 years experience in mining and plant operation, project studies, management, and engineering.
- I am a “Qualified Person” for purposes of National Instrument 43-101 (the “Instrument”).
- My most recent personal inspection of the Property was on September 1 and 2, 2010.
- I am responsible for Sections 1.0, 2.0, 3.0, 16.0, 18.2, and 18.7 of the Technical Report, as well as capital costs pertaining to process in Section 18.5.
- I am independent of Northern Dynasty Minerals Ltd. as defined by Section 1.4 of the Instrument.
- I have no prior involvement with the Property that is the subject of the Technical Report.
- I have read the Instrument and the technical report has been prepared in compliance with the Instrument.
- As of the date of this certificate, to the best of my knowledge, information and belief, the technical report contains all scientific and technical information that is required to be disclosed to make the technical report not misleading.

Signed and dated this 17th day of February, 2011 at Vancouver, BC.

*“Original document signed and sealed  
by Hassan Ghaffari, P.Eng.”*

---

Hassan Ghaffari, P.Eng.  
Manager of Metallurgy  
Wardrop Engineering Inc.

# CERTIFICATE OF QUALIFIED PERSON

---

I, Robert Sinclair Morrison, of Toronto, Ontario, do hereby certify:

- I am a Lead Resource Geologist with Wardrop Engineering Inc. with a business address at 330 Bay Street, Suite 900, Toronto, Ontario, Canada, M5H 2S8.
- This certificate applies to the technical report entitled "Preliminary Assessment of the Pebble Project, Southwest Alaska", dated February 17, 2011 (the "Technical Report").
- I am a graduate of Acadia University (B.Sc., 1981), and the University of Adelaide (Ph.D., 1990).
- I am a member in good standing Member of the Australasian Institute of Mining and Metallurgy (#11212), and I am registered as a Chartered Professional in Geology with the Australasian Institute of Mining and Metallurgy since 2004. I am also a member in good standing with the Association of Professional Geoscientists of Ontario (#1839).
- My relevant experience includes 10 years in extensional exploration, deposit research, resource modelling and estimation with WMC Resources Ltd and Gold Fields Ltd in Western Australia (Archaean mesothermal shear-hosted gold deposits), 3 years in deposit research, resource modelling and estimation with BHP Billiton Ltd in South Australia (Mesoproterozoic IOCG deposits – i.e. Olympic Dam) and two years in resource modelling and resource estimation of granite-hosted porphyry Cu-Mo-Sn systems with Wardrop Engineering Inc. (e.g. Ann Mason, Nevada and East Kemptville, Nova Scotia).
- I am a "Qualified Person" for purposes of National Instrument 43-101 (the "Instrument").
- I have conducted a personal inspection of the Property in September 2010.
- I am responsible for Sections 4.0 to 15.0 and 17.0 of the Technical Report, as well as those portions of 19.0 and 20.0 that pertain to geology.
- I am independent of Northern Dynasty Minerals Ltd. as defined by Section 1.4 of the Instrument.
- I have no prior involvement with the Property that is the subject of the Technical Report.
- I have read the Instrument and the technical report has been prepared in compliance with the Instrument.
- As of the date of this certificate, to the best of my knowledge, information and belief, the technical report contains all scientific and technical information that is required to be disclosed to make the technical report not misleading.

Signed and dated this 17th day of February, 2011 at Toronto, ON

*"Original document signed and sealed by Robert S.  
Morrison, B.Sc, Ph.D., MAusIMM (CP), P.Geo."*

---

Robert S. Morrison, B.Sc, Ph.D., MAusIMM (CP), P.Geo.  
Lead Resource Geologist  
Wardrop Engineering Inc.

# CERTIFICATE OF QUALIFIED PERSON

---

I, Marinus Andre de Ruijter, of Delta, British Columbia, do hereby certify:

- I am a Senior Metallurgical Engineer at Wardrop Engineering Inc. with a business address at #800 – 555 West Hastings St., Vancouver, BC, V6B 1M1.
- This certificate applies to the technical report entitled “Preliminary Assessment of the Pebble Project, Southwest Alaska”, dated February 17, 2011 (the “Technical Report”).
- I am a graduate of the University of Witwatersrand, Johannesburg, South Africa (B.Sc. Physics, Mathematics, 1970; B.Eng, 1973; M.Eng., 1979).
- I am a member in good standing of the Association of Professional Engineers and Geoscientists of British Columbia (Registration #31031).
- My relevant experience with respect to this project includes copper and base metal sulphide mineral flotation projects, and 25 years experience in the gold industry encompassing laboratory research and development, operational gold plant responsibility, and process plant design.
- I am a “Qualified Person” for purposes of National Instrument 43-101 (the “Instrument”).
- I have not conducted a personal inspection of the Property.
- I am responsible for Section 16.0 of the Technical Report, as well as operating costs pertaining to process and general and administration in Sections 18.6, 19.0, and 20.0, and those portions of 19.0 and 20.0 pertaining to process.
- I am independent of Northern Dynasty Minerals Ltd. as defined by Section 1.4 of the Instrument.
- I have no prior involvement with the Property that is the subject of the Technical Report.
- I have read the Instrument and the technical report has been prepared in compliance with the Instrument.
- As of the date of this certificate, to the best of my knowledge, information and belief, the technical report contains all scientific and technical information that is required to be disclosed to make the technical report not misleading.

Signed and dated this 17th day of February, 2011 at Vancouver, BC

*“Original document signed and sealed  
by Marinus Andre de Ruijter, P.Eng.”*

---

Marinus Andre de Ruijter, P.Eng.  
Senior Metallurgical Engineer  
Wardrop Engineering Inc.

# CERTIFICATE OF QUALIFIED PERSON

---

I, Aleksandar Živković, of Toronto, Ontario, do hereby certify:

- I am the Manager, Geotechnical Engineering with Wardrop Engineering Inc. with a business address at #900 – 330 Bay St., Toronto, ON, M5H 2S8.
- This certificate applies to the technical report entitled “Preliminary Assessment of the Pebble Project, Southwest Alaska”, dated February 17, 2011 (the “Technical Report”).
- I am a graduate of the University of Belgrade, (dipl. ing., B.A.Sc., Geological Option of Geological Engineering, 1986).
- I am a member in good standing of the Association of Professional Engineers and Geoscientists of: Ontario (#90375882), British Columbia (#25771), Manitoba (#32434), and Saskatchewan (License #16969), as well as the Association of Professional Engineers, Geologists and Geophysicists of Alberta (License # 113119).
- My relevant experience with respect to this study covers geotechnical engineering design aspects of the development of mine infrastructure and mine waste management including numerous projects in Canada, United States, Europe, Australasia, Latin America and Africa for the past 24 years.
- I am a “Qualified Person” for purposes of National Instrument 43-101 (the “Instrument”).
- I have not conducted a personal inspection of the Property.
- I am responsible for Section 18.3 of the Technical Report, as well as those portions of Section 18.5, 19.0, and 20.0 that pertain to tailings.
- I am independent of Northern Dynasty Minerals Ltd. as defined by Section 1.4 of the Instrument.
- I have no prior involvement with the Property that is the subject of the Technical Report.
- I have read the Instrument and the technical report has been prepared in compliance with the Instrument.
- As of the date of this certificate, to the best of my knowledge, information and belief, the technical report contains all scientific and technical information that is required to be disclosed to make the technical report not misleading.

Signed and dated this 17th day of February, 2011 at Toronto, Ontario

*“Original document signed and sealed  
by Aleksandar Živković, P.Eng.”*

---

Aleksandar Živković, P.Eng.  
Manager, Geotechnical Engineering  
Wardrop Engineering Inc.



# CERTIFICATE OF QUALIFIED PERSON

---

I, Tysen Hantelmann, of Edmonton, Alberta, do hereby certify:

- I am a Senior Mining Engineer with Wardrop Engineering Inc. with a business address at: 14940 – 123 Avenue, Edmonton, AB, T5V 1B4.
- This certificate applies to the technical report entitled “Preliminary Assessment of the Pebble Project, Southwest Alaska”, dated February 17, 2011 (the “Technical Report”).
- I am a graduate of the University of Alberta (B.Sc., Mining Engineering, 2001; M.Eng., Mining Engineering, 2003).
- I am a member in good standing of the Association of Professional Engineers and Geoscientists of Alberta (M71697).
- My relevant experience is 11 years of mine engineering and mine operations experience including long-range and short-range production scheduling, pit optimization, pit and dump design, operating and capital cost estimation and financial analysis.
- I am a “Qualified Person” for purposes of National Instrument 43-101 (the “Instrument”).
- My most recent personal inspection of the Property was September 1, 2010 for 1 day.
- I am responsible for Section 18.1 of the Technical Report and those portions of Sections 18.5, 18.6, 19.0 and 20.0 that pertain to mining.
- I am independent of Northern Dynasty Minerals Ltd. as defined by Section 1.4 of the Instrument.
- I have no prior involvement with the Property that is the subject of the Technical Report.
- I have read the Instrument and the technical report has been prepared in compliance with the Instrument.
- As of the date of this certificate, to the best of my knowledge, information and belief, the technical report contains all scientific and technical information that is required to be disclosed to make the technical report not misleading.

Signed and dated this 17th day of February, 2011 at Edmonton, Alberta

*“Original document signed and sealed  
by Tysen Hantelmann, P.Eng., M.Eng.”*

---

Tysen Hantelmann, P.Eng. M.Eng.  
Senior Mining Engineer  
Wardrop Engineering Inc.

# CERTIFICATE OF QUALIFIED PERSON

---

I, Douglas Ramsey, of Vancouver, BC, do hereby certify:

- I am a Manager – Environmental Assessment, Permitting, and Natural Resources with Wardrop Engineering Inc. with a business address at #800 – 555 West Hastings St., Vancouver, BC, V6B 1M1.
- This certificate applies to the technical report entitled “Preliminary Assessment of the Pebble Project, Southwest Alaska”, dated February 17, 2011 (the “Technical Report”).
- I am a graduate of the University of Manitoba (B.Sc. (Hons) Zoology, 1979; M.Sc. Zoology, 1985).
- I am a member in good standing of the College of Applied Biology, British Columbia, as a Registered Professional Biologist (#1581).
- My relevant experience is 28+ years as an environmental consultant working in environmental permitting, and 22 years of experience in the environmental permitting, monitoring, and closure of mining projects.
- I am a “Qualified Person” for purposes of National Instrument 43-101 (the “Instrument”).
- I have not conducted a personal inspection of the Property.
- I am responsible for Section 18.4 of the Technical Report, as well as those portions of Sections 19.0 and 20.0 pertaining to sustainability, water, and stakeholder relations.
- I am independent of Northern Dynasty Minerals Ltd. as defined by Section 1.4 of the Instrument.
- I have no prior involvement with the Property that is the subject of the Technical Report.
- I have read the Instrument and the technical report has been prepared in compliance with the Instrument.
- As of the date of this certificate, to the best of my knowledge, information and belief, the technical report contains all scientific and technical information that is required to be disclosed to make the technical report not misleading.

Signed and dated this 17th day of February, 2011 at Vancouver, BC

*“Original document signed and sealed  
by Douglas Ramsey, R.P.Bio (BC)”*

---

Douglas Ramsey, R.P.Bio. (BC)  
Manager – Environmental Assessment,  
Permitting, and Natural Resources  
Wardrop Engineering Inc.

# CERTIFICATE OF QUALIFIED PERSON

---

I, Scott Cowie, of Perth, Australia, do hereby certify:

- I am the General Manager with Tetra Tech Australia Pty. Ltd. with a business address at Level 5, 220 St Georges Tce, Perth, WA, 6000.
- This certificate applies to the technical report entitled "Preliminary Assessment of the Pebble Project, Southwest Alaska", dated February 17, 2011 (the "Technical Report").
- I am a graduate of the University of Queensland (Bachelor of Engineering (Mining), 2001) and Queensland University of Technology (Bachelor of Laws, 2009).
- I am a member in good standing of the Australasian Institute of Mining and Metallurgy (Member Number: 206253).
- I have nine (9) years of experience as a mining engineer in both engineering and operating environments including mineral reserve estimation, mine optimization, mine cost estimation, and various operational roles.
- My relevant experience with respect to financial modelling includes completion of scoping study to feasibility study mineral project evaluations for base, industrial, and precious metals.
- I am a "Qualified Person" for purposes of National Instrument 43-101 (the "Instrument").
- I have not conducted a personal inspection of the Property.
- I am responsible for Section 18.8 of the Technical Report, as well as those portions of Sections 19.0 and 20.0 that pertain to the financial model.
- I am independent of Northern Dynasty Minerals Ltd. as defined by Section 1.4 of the Instrument.
- I have no prior involvement with the Property that is the subject of the Technical Report.
- I have read the Instrument and the technical report has been prepared in compliance with the Instrument.
- As of the date of this certificate, to the best of my knowledge, information and belief, the technical report contains all scientific and technical information that is required to be disclosed to make the technical report not misleading.

Signed and dated this 17th day of February, 2011 at Perth, Australia

*"Original document signed  
by Scott Cowie, MAusIMM"*

---

Scott Cowie, MAusIMM  
General Manager  
Tetra Tech Australia Pty. Ltd.